

US00D384028S

United States Patent [19]
Veazey

[11] **Patent Number:** **Des. 384,028**
[45] **Date of Patent:** ****Sep. 23, 1997**

[54] **TWIN-HULLED BOAT**

4,140,076 2/1979 Borglum .
5,379,710 1/1995 Parnigoni .

[75] **Inventor:** **Sidney E. Veazey**, King George, Va.

FOREIGN PATENT DOCUMENTS

[73] **Assignee:** **S. E. Ventures, Inc.**, King George, Va.

2648778 12/1990 France .

[**] **Term:** **14 Years**

Primary Examiner—Kay H. Chin
Attorney, Agent, or Firm—James K. Poole, Esq.

[21] **Appl. No.:** **49,159**

[57] **CLAIM**

[22] **Filed:** **Jan. 18, 1996**

The ornamental design for the twin-hulled boat, as shown and described.

Related U.S. Application Data

DESCRIPTION

[63] **Continuation of Ser. No. 224,675**, Apr. 7, 1994.

[51] **LOC (6) Cl.** **12-06**

FIG. 1 is a perspective top view;

[52] **U.S. Cl.** **D12/300; D12/304**

FIG. 2 is a left (port) side view;

[58] **Field of Search** **D12/300, 310-314, D12/316, 304; 114/61, 345, 352-354**

FIG. 3 is a front view;

FIG. 4 is a plan view;

FIG. 5 is a rear view; and,

FIG. 6 is a bottom view, the left and right (starboard) side views being symmetric.

[56] **References Cited**

U.S. PATENT DOCUMENTS

3,046,926 7/1962 Miller .

1 Claim, 6 Drawing Sheets

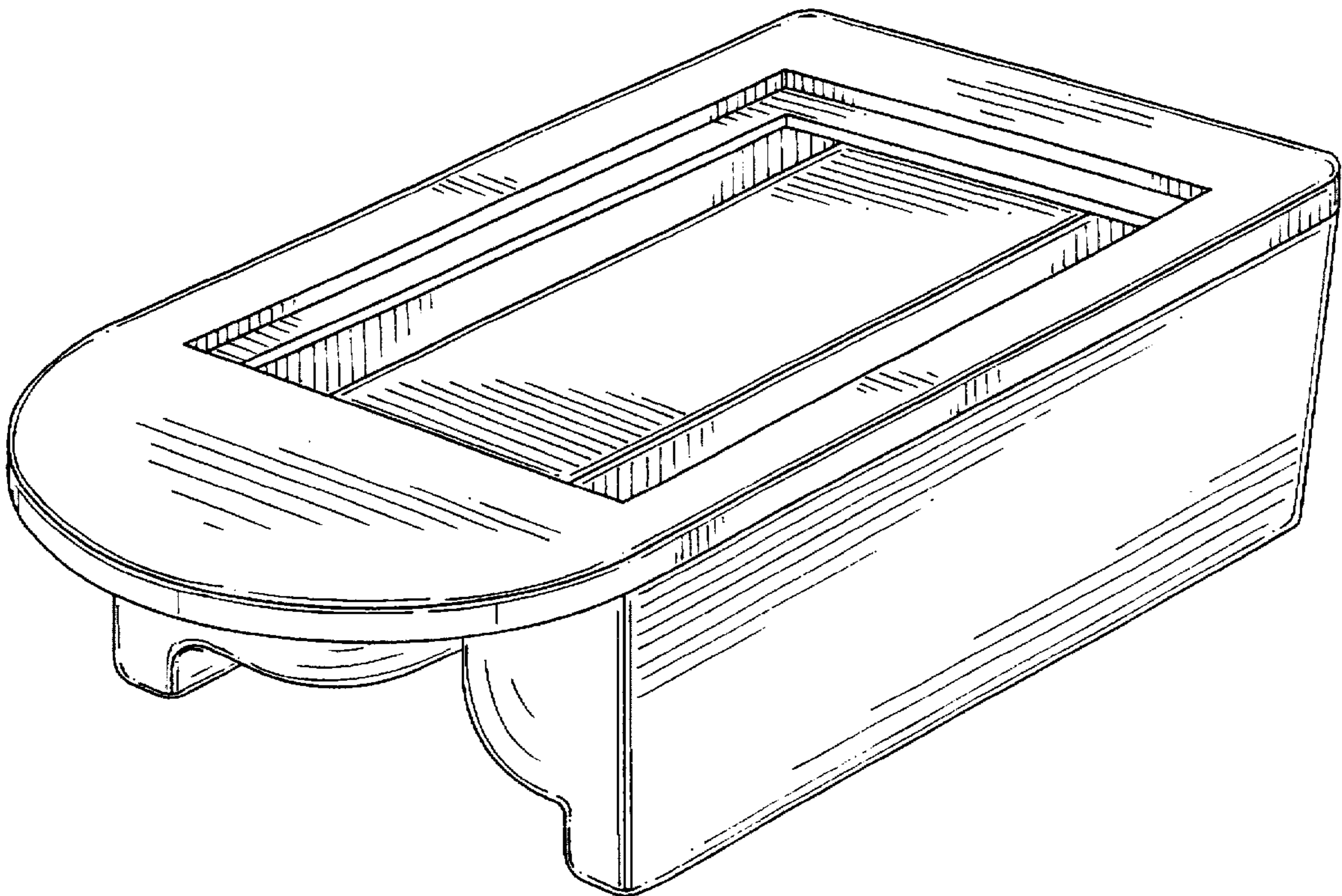

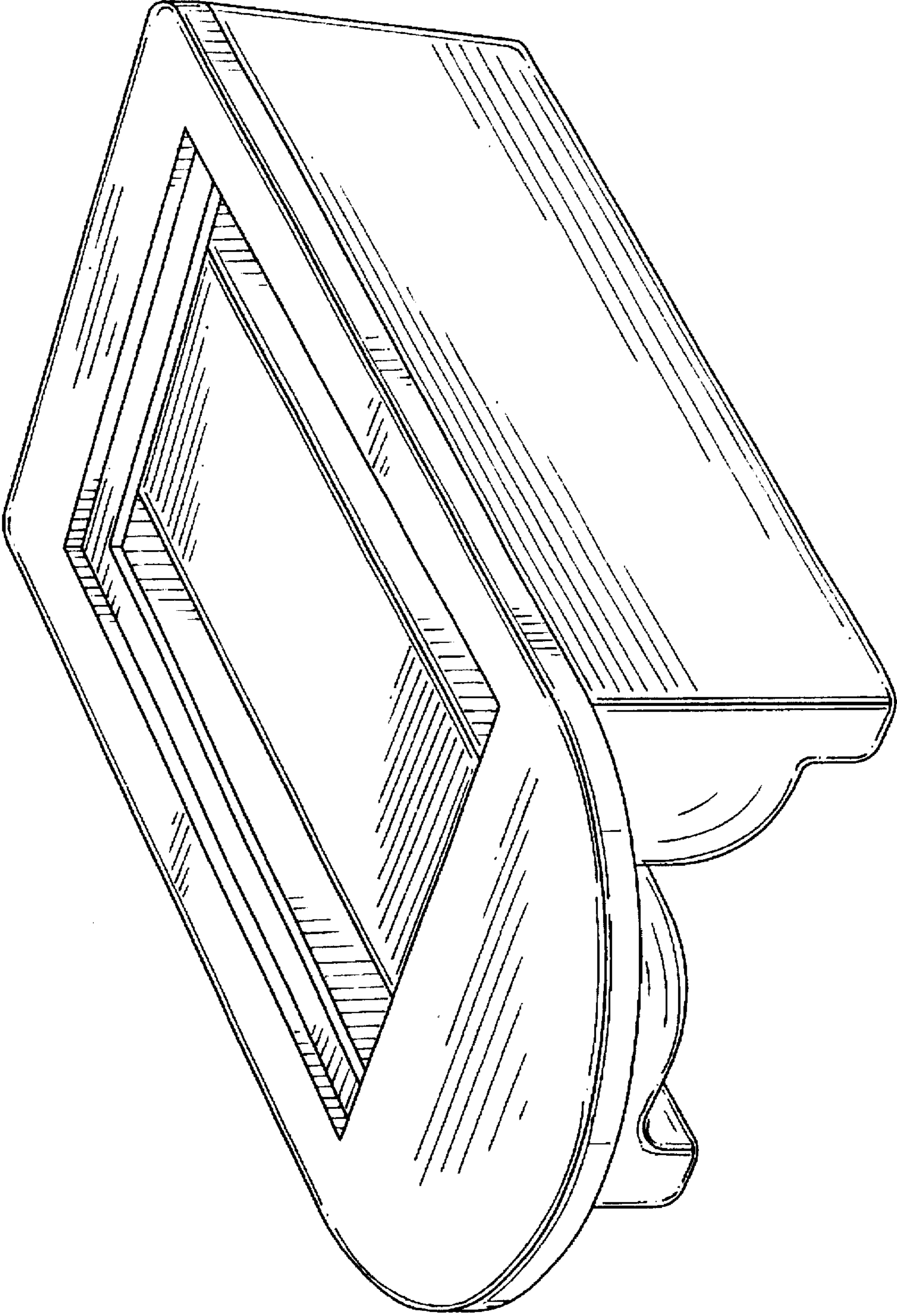
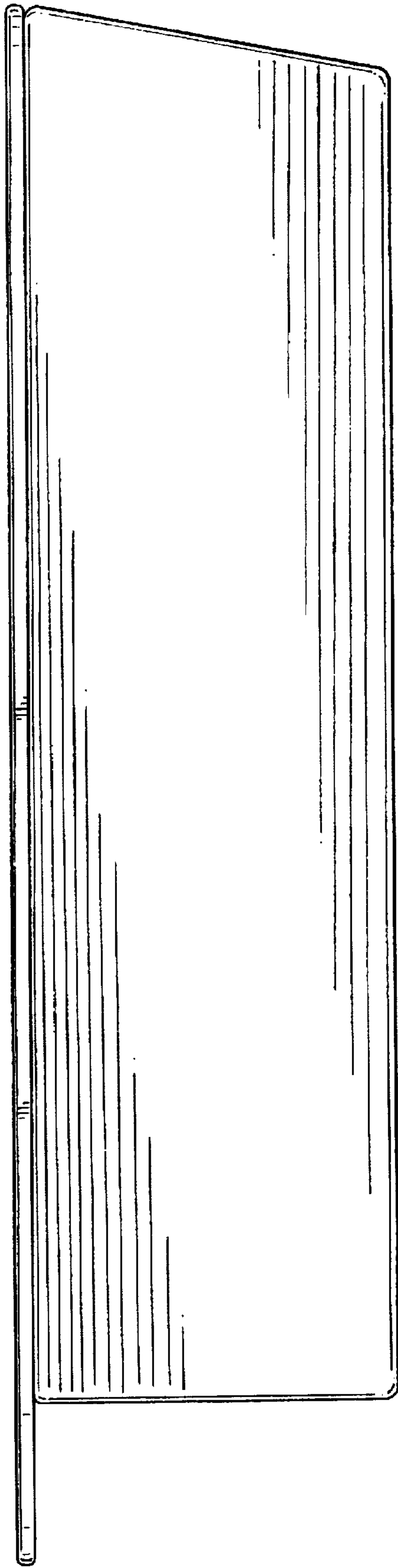

FIG-1

FIG-2



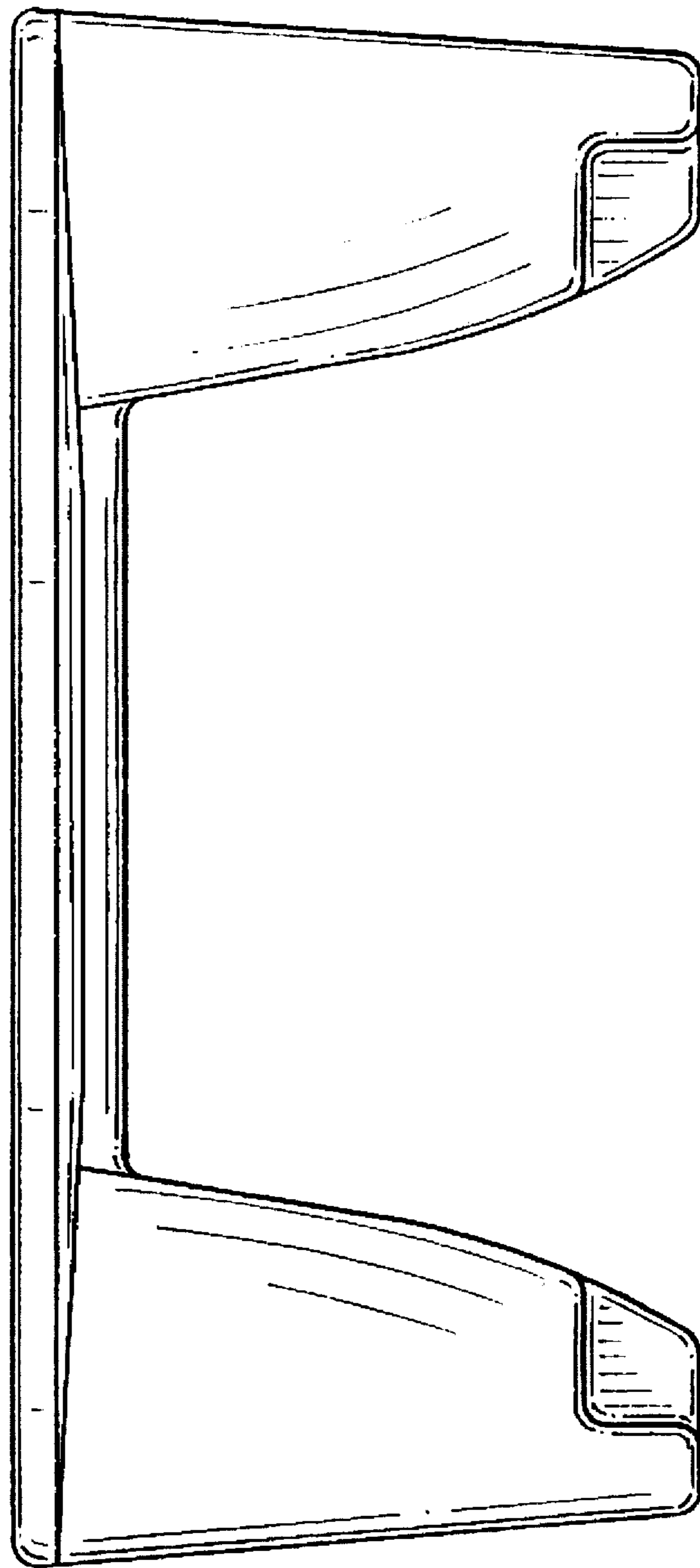

FIG-3

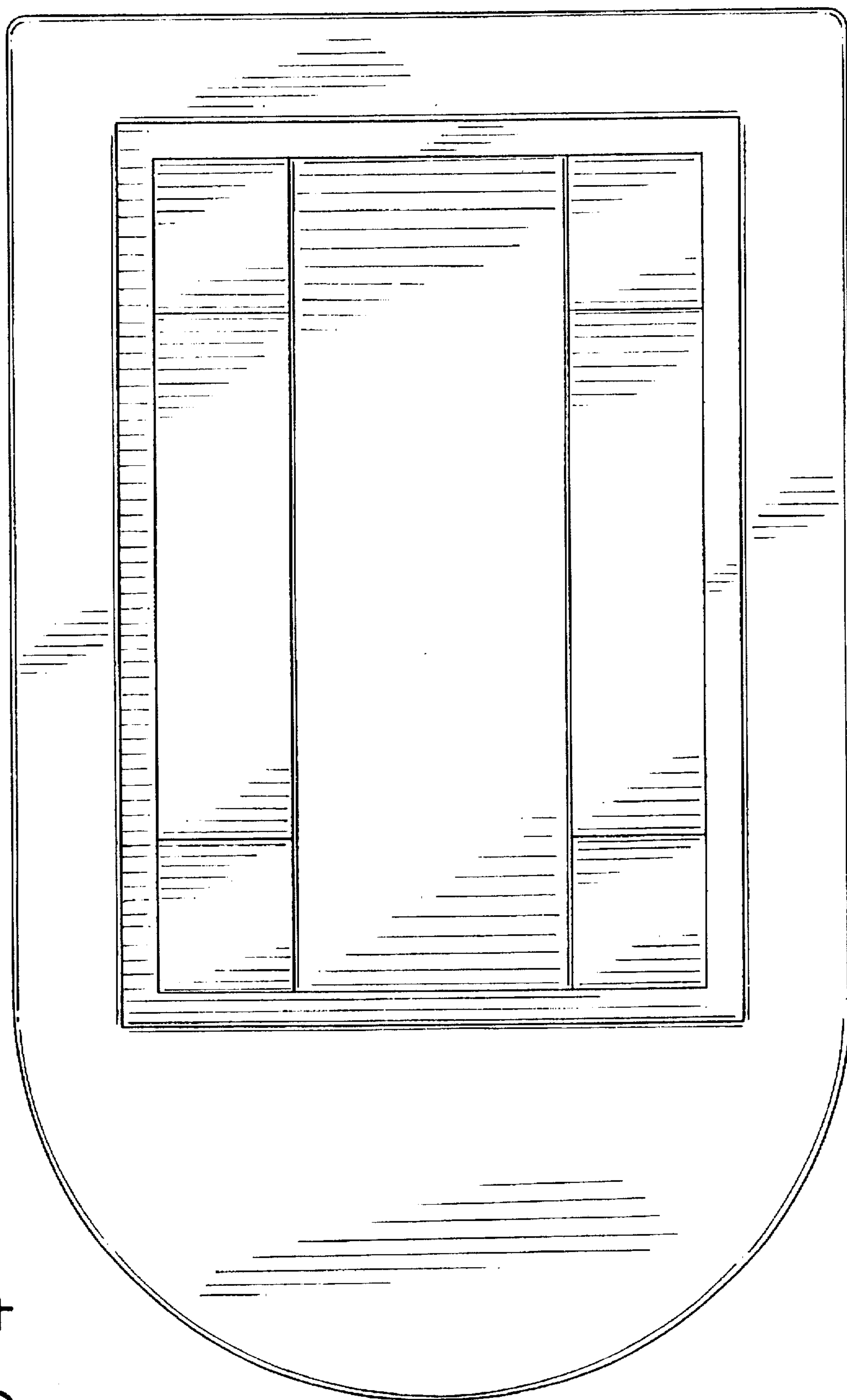
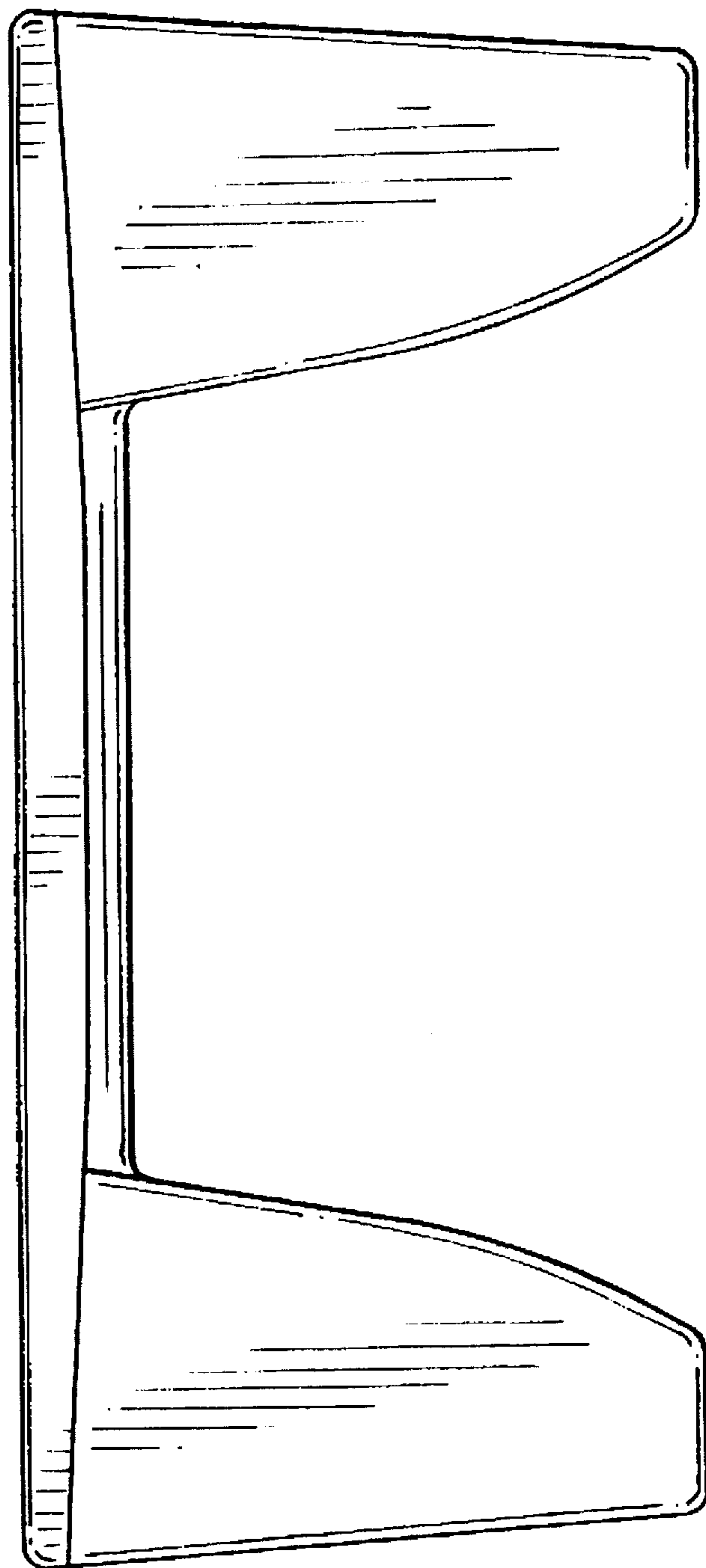

FIG-4

FIG-5



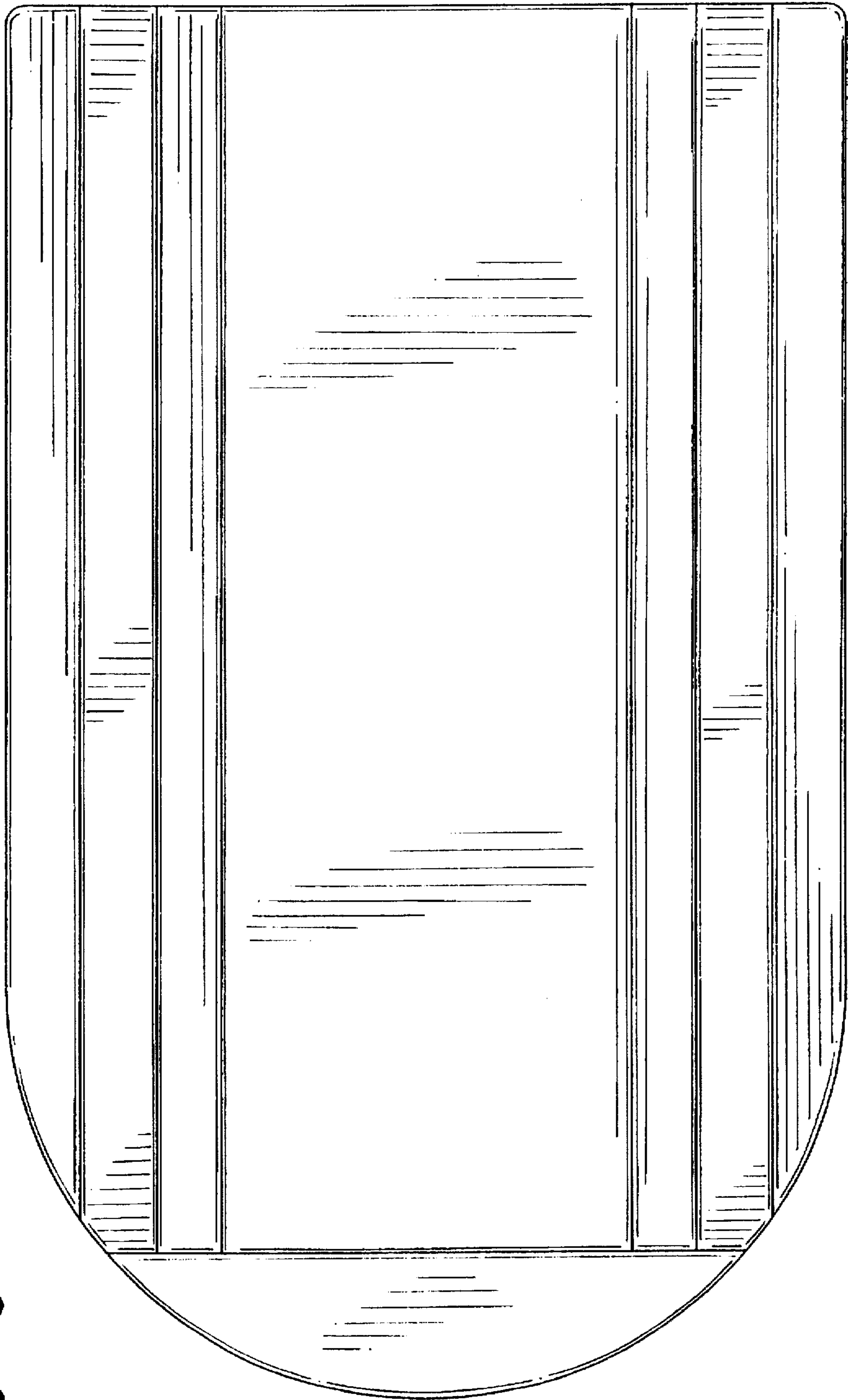

FIG-6