

US00D384019S

United States Patent [19]

[11] Patent Number: **Des. 384,019**

Meryman et al.

[45] Date of Patent: ****Sep. 23, 1997**

[54] **TRUCK SUN VISOR**

[75] Inventors: **Roy L. Meryman**, Renton; **Wayne K. Simons**, Kent, both of Wash.

[73] Assignee: **PACCAR Inc.**, Bellevue, Wash.

[**] Term: **14 Years**

[21] Appl. No.: **53,890**

[22] Filed: **May 1, 1996**

[51] LOC (6) Cl. **12-06**

[52] U.S. Cl. **D12/191**

[58] Field of Search D12/181, 182, D12/190, 206, 93; 296/180.1, 180.2, 180.4, 180.3; 80/89.14, 89.16, 89.18, 89.19

[56] **References Cited**

U.S. PATENT DOCUMENTS

D. 261,500	10/1981	Butler	D12/191
D. 273,672	5/1984	Lund	D12/191
D. 340,025	10/1993	Brownlie et al.	D12/181
5,130,906	7/1992	Lund	296/95.1 X
5,522,634	6/1996	Stanesic et al.	296/95.1

OTHER PUBLICATIONS

- "Kenworth The World's Best", Kenworth Truck Company brochure, Kirkland, WA (Admitted Prior Art).
- "Kenworth Historical Background", Kenworth Truck Company brochure, Kirkland, WA (Admitted Prior Art).
- "Kenworth K100E ", Canadian Kenworth Truck Company brochure, Mississauga, Ontario (Admitted Prior Art).
- "Kenworth T300 ", Kenworth Truck Company brochure, Kirkland, WA (Admitted Prior Art).
- "Kenworth T400B T450B", Kenworth Truck Company brochure, Kirkland, WA (Admitted Prior Art).
- "Kenworth C500B The Ultimate Survivor ", Kenworth Truck Company brochure, Kirkland, WA (Admitted Prior Art).
- "Kenworth's T600: Ten Years of Innovatiuon ", Kenworth Truck Company brochure, Kirkland, WA (Jun. 1995).
- "Kenworth T600 ", Kenworth Truck Company brochure, Kirkland WA (Admitted Prior Art).

"Kenworth T600A, The Conventional Made Extraordinary ", Kenworth Truck Company Brochure, Kirkland, WA (Admitted Prior Art).

"Kenworth T800 ", Kenworth Truck Company brochure, Kirkland, WA (Admitted Prior Art).

"Kenworth T800B ", Kenworth Truck Company brochure, Kirkland, WA (Admitted Prior Art).

"Kenworth W900 ", Kenworth Truck Company brochure, Kirkland, WA (Admitted Prior Art).

"Kenworth W900L Aerocab ", Kenworth Truck Company brochure, Kirkland, WA (Admitted Prior Art).

(List continued on next page.)

Primary Examiner—Louis S. Zarfes

Assistant Examiner—Frank Martinez

Attorney, Agent, or Firm—Wells, St. John, Roberts, Gregory & Matkin, P.S.

[57] **CLAIM**

The ornamental design for truck sun visor, as shown and described.

DESCRIPTION

FIG. 1 is a front view of a first embodiment of a truck sun visor showing our new design;
 FIG. 2 is a side view thereof;
 FIG. 3 is a side view thereof, shown in an enlarged scale;
 FIG. 4 is a side view thereof, the opposite side being a mirror image thereof;
 FIG. 5 is a front view thereof;
 FIG. 6 is a rear view thereof;
 FIG. 7 is a top view thereof;
 FIG. 8 is a bottom view thereof;
 FIG. 9 is a side view of a second embodiment of a truck sun visor showing our new design, the opposite side being a mirror image thereof;
 FIG. 10 is a front view thereof;
 FIG. 11 is a rear view thereof;
 FIG. 12 is a top view thereof; and,
 FIG. 13 is a bottom view thereof.

The broken line showing of a vehicle is for illustrative purposes only and forms no part of the claimed design.

1 Claim, 8 Drawing Sheets

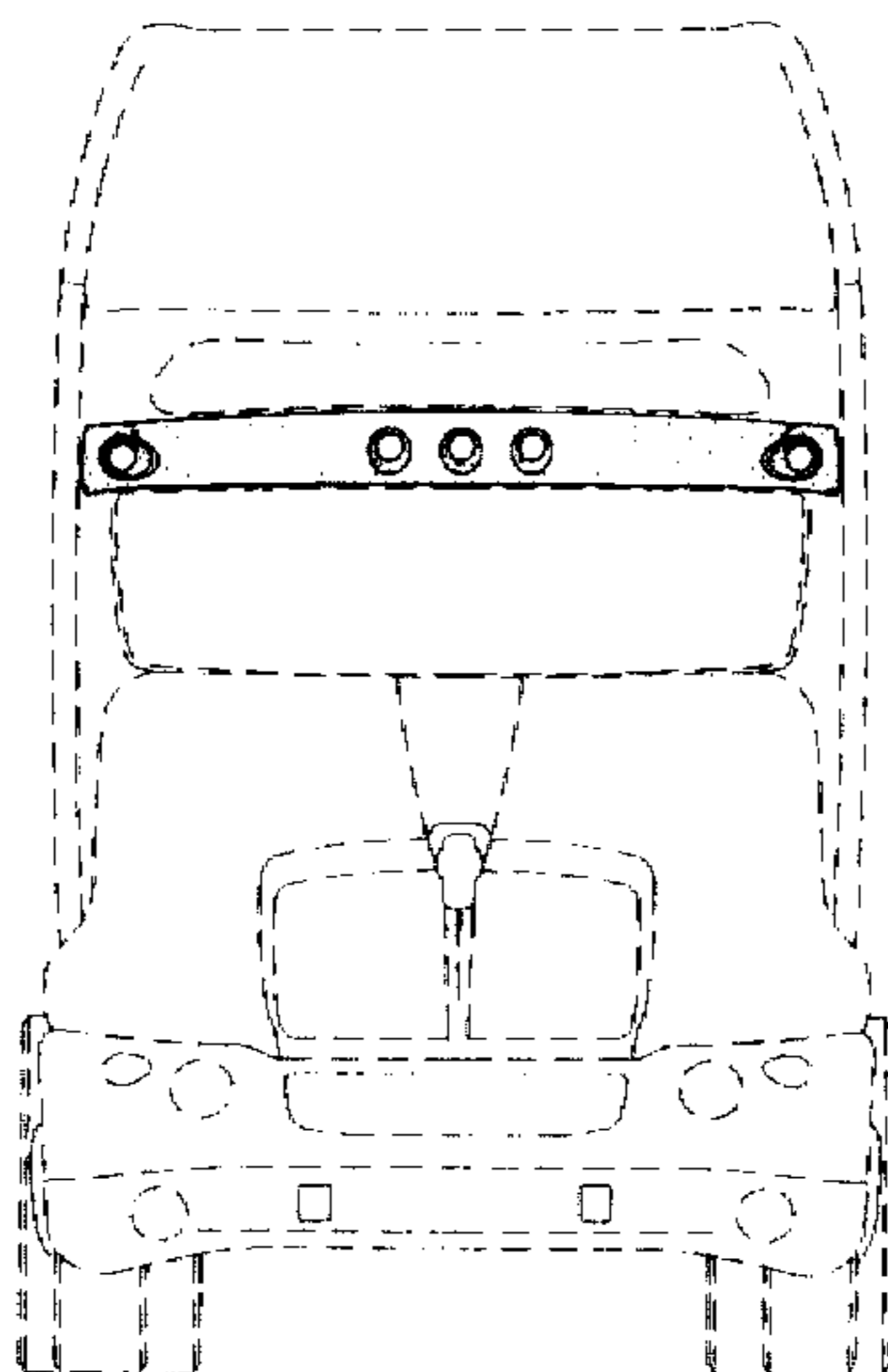

OTHER PUBLICATIONS

"Kenworth Construction Trucks ", Candian Kenworth Truck Company brochure, Mississauga, Ontario (Admitted Prior Art).

"Kenworth Aerocab ", Kenworth Truck Company brochure, Kirkland, WA (Admitted Prior Art).

"Last Year, One Idea Changed A Lot of Attitudes About Driver Retention—Aerocab ", Kenworth Truck Company brochure, Kirkland, WA (Admitted Prior Art).

"Kenworth Studio Sleeper ", Kenworth Truck Company brochure, Kirkland, WA (Admitted Prior Art).

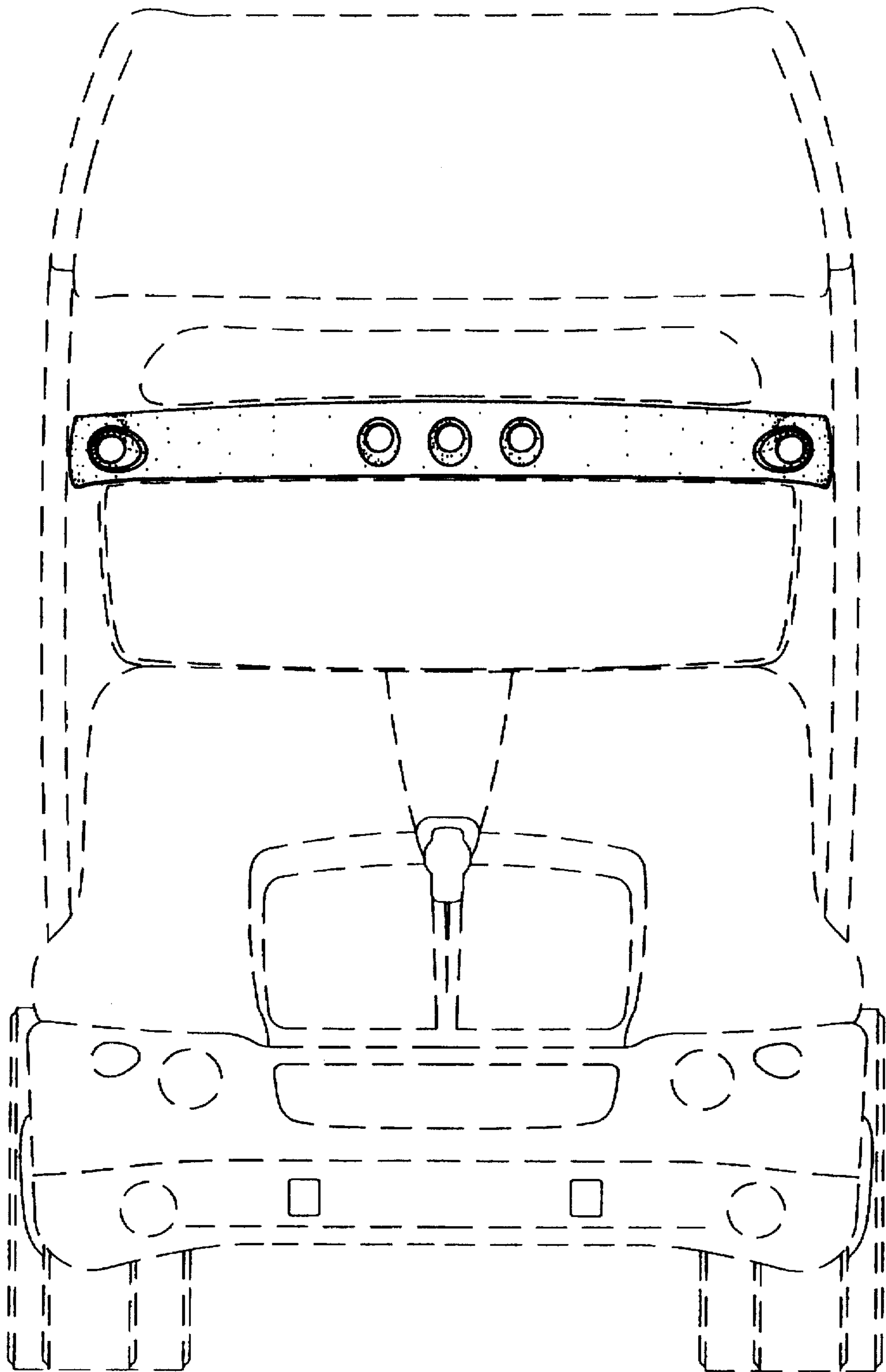
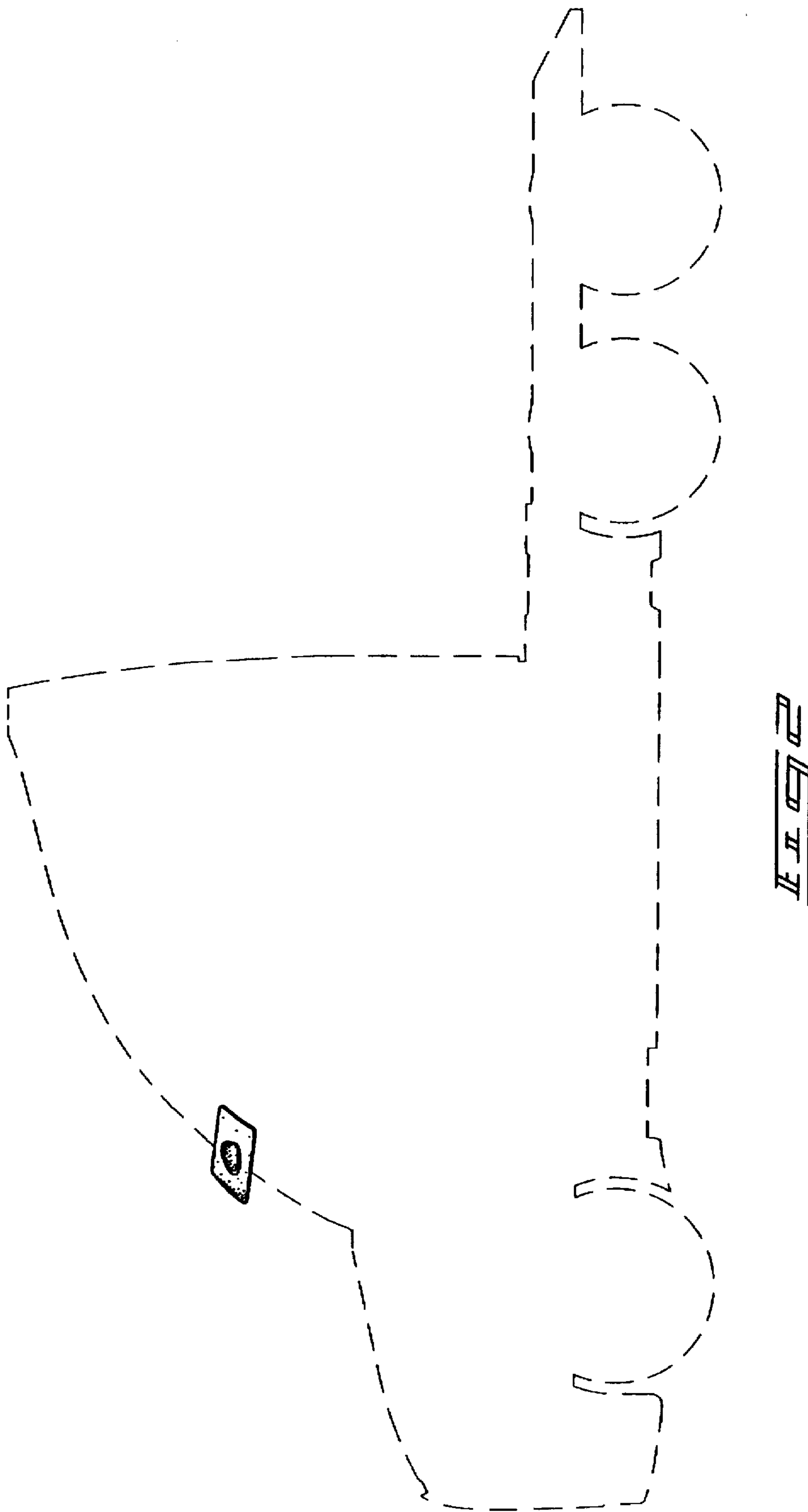

FIG. 1



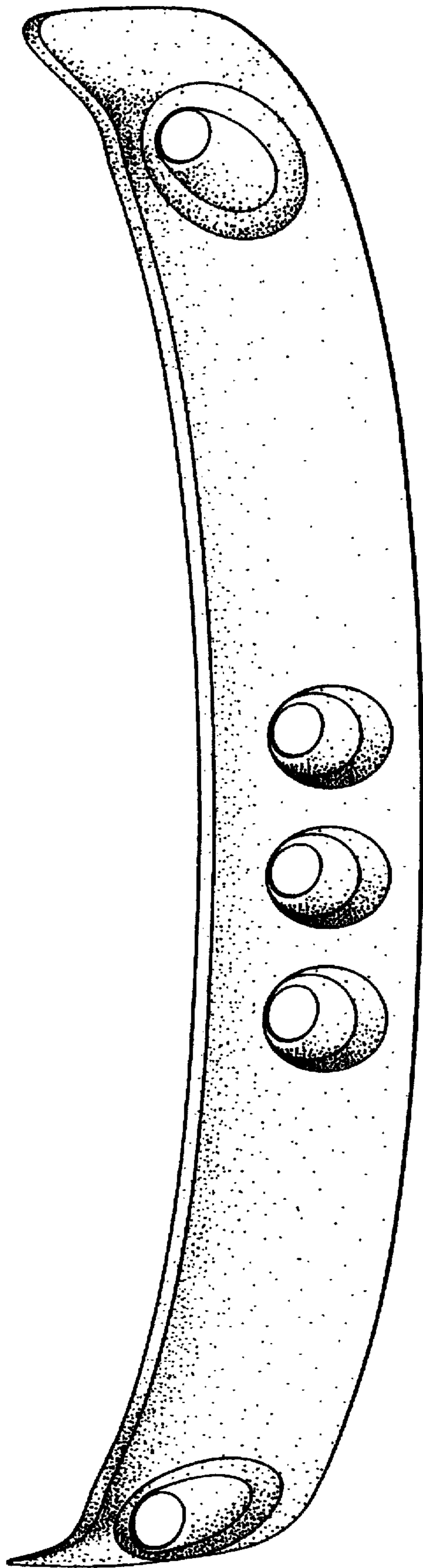

FIG. 3

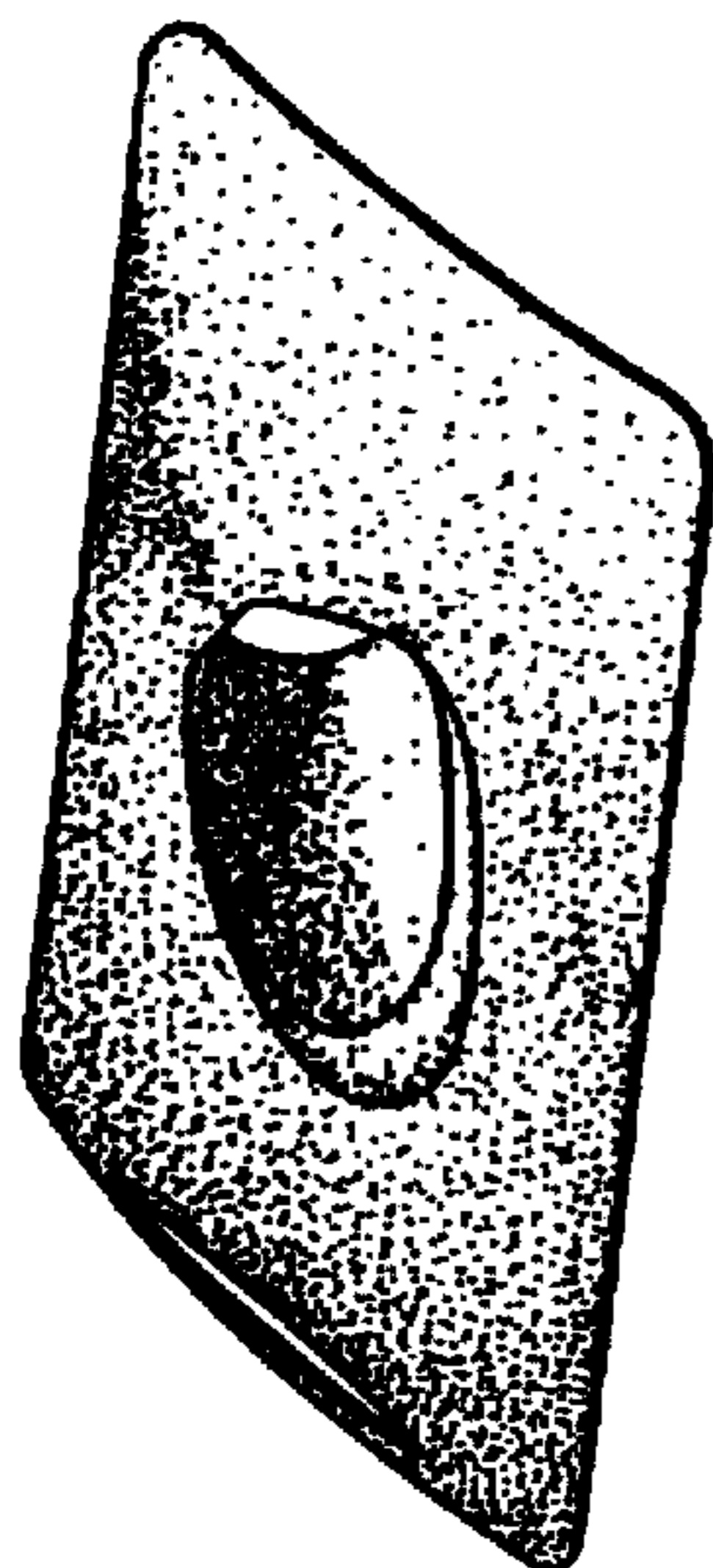

FIG. 5

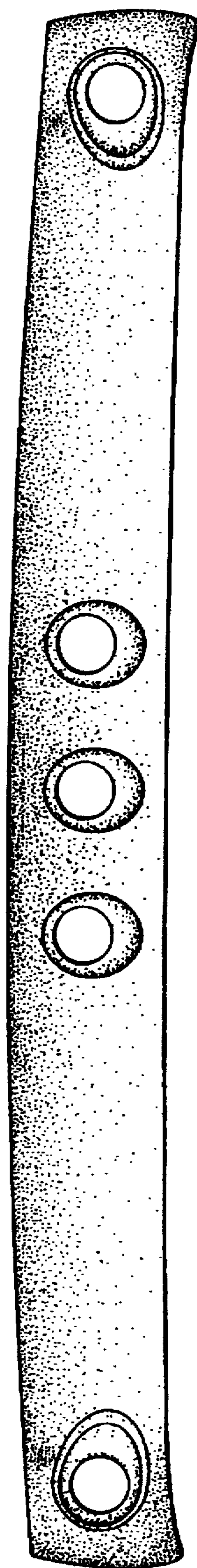

FIG. 6

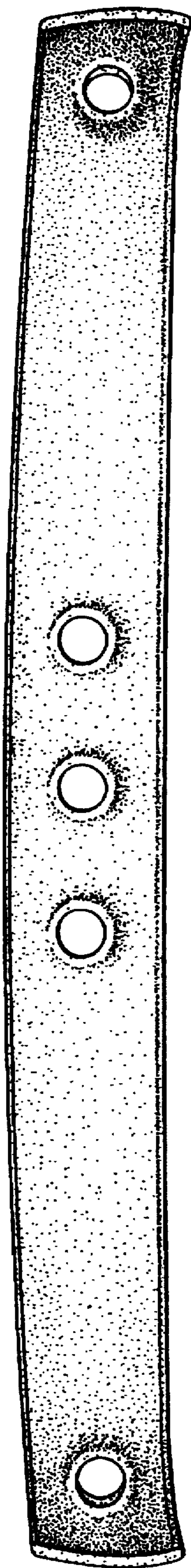

Fig. 5

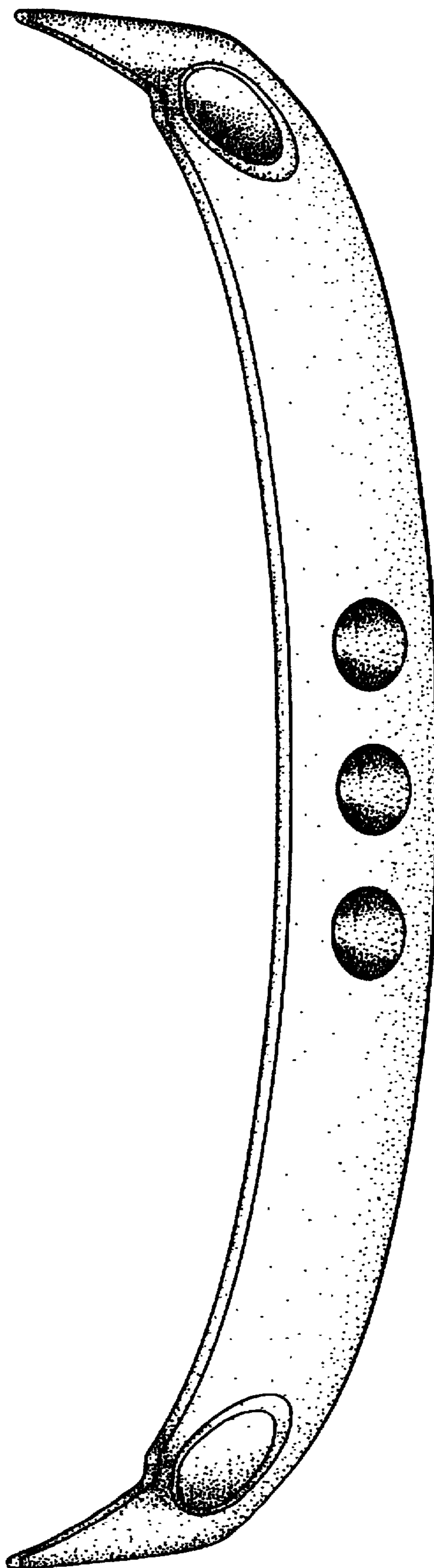

Fig. 6

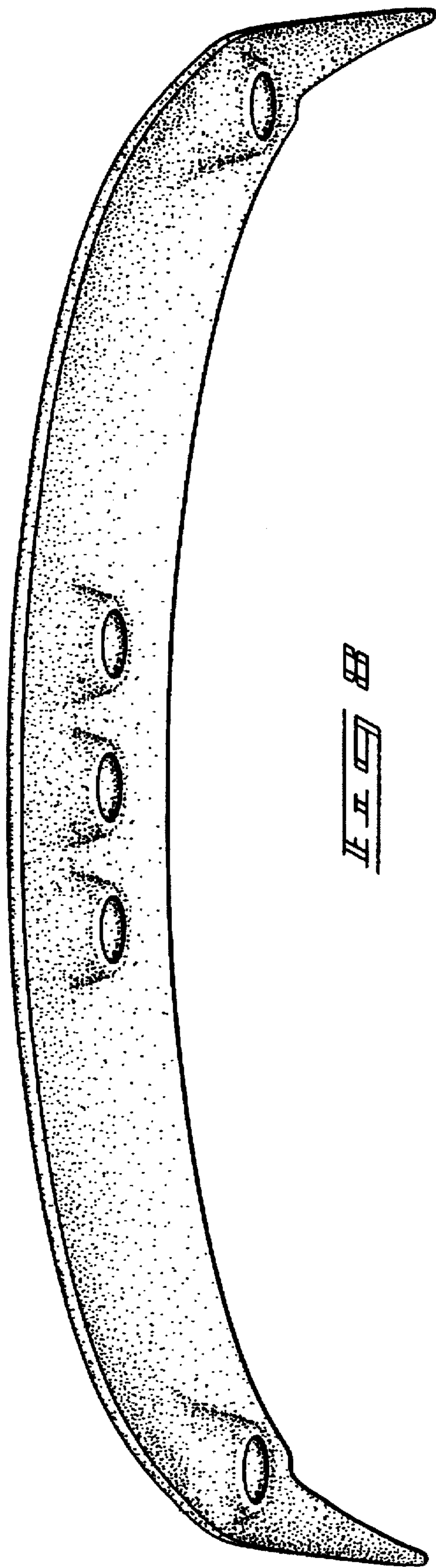

FIG. 7

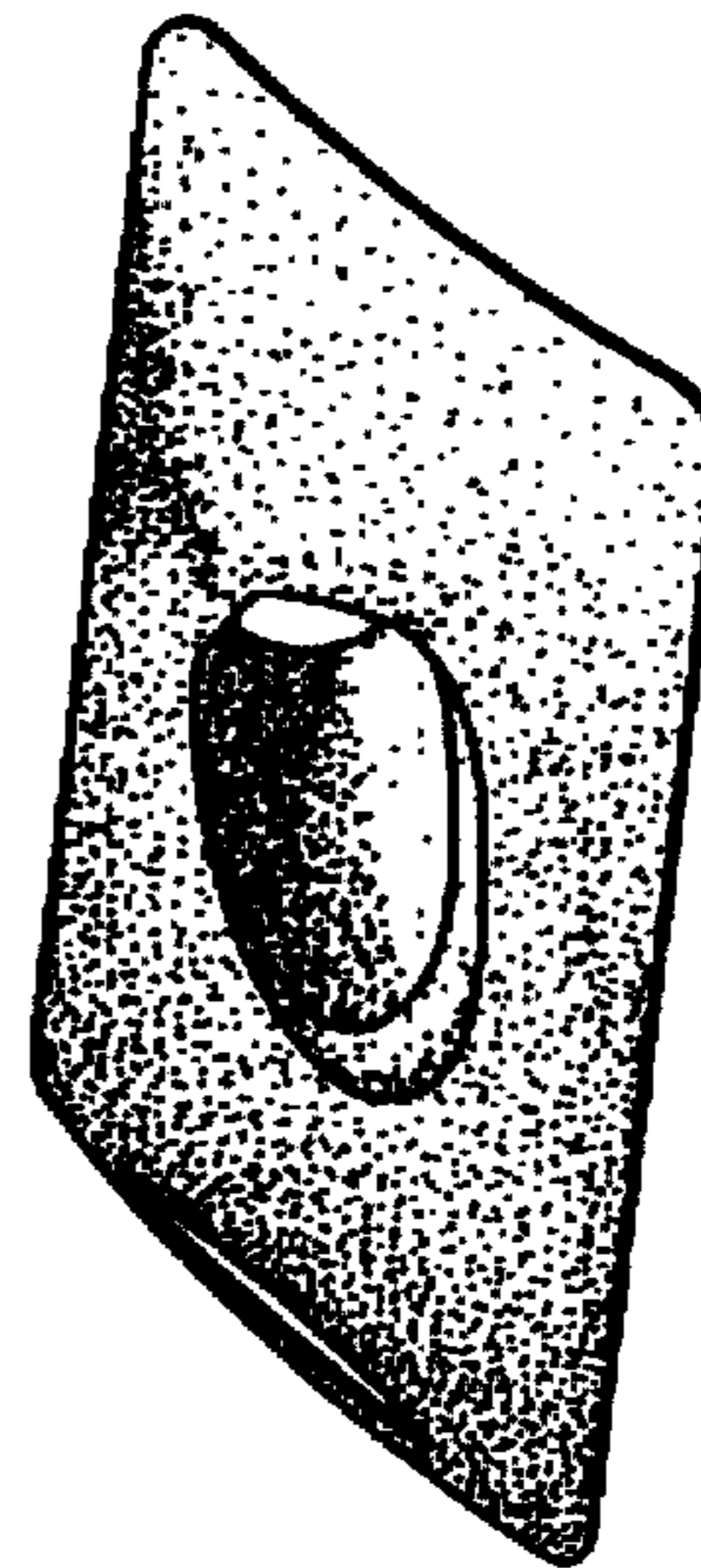

FIG. 8

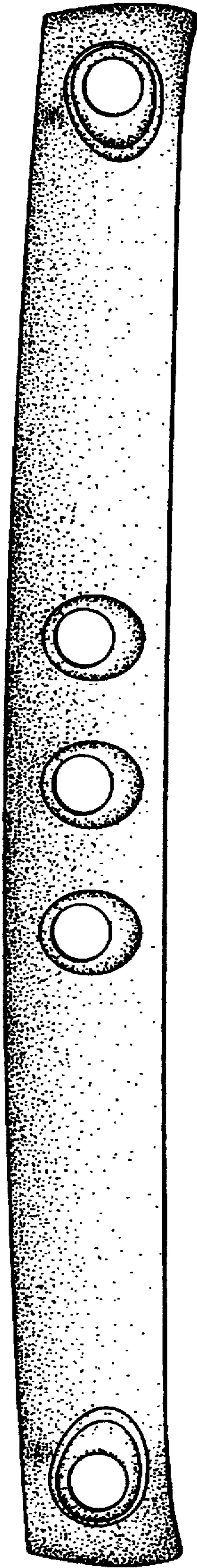

FIG. 1

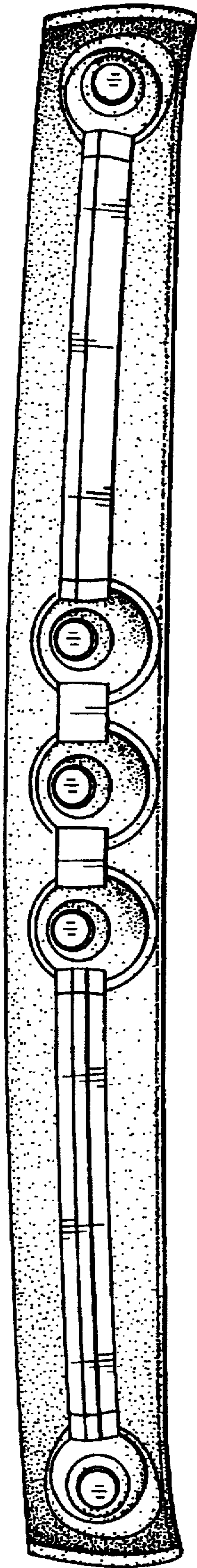
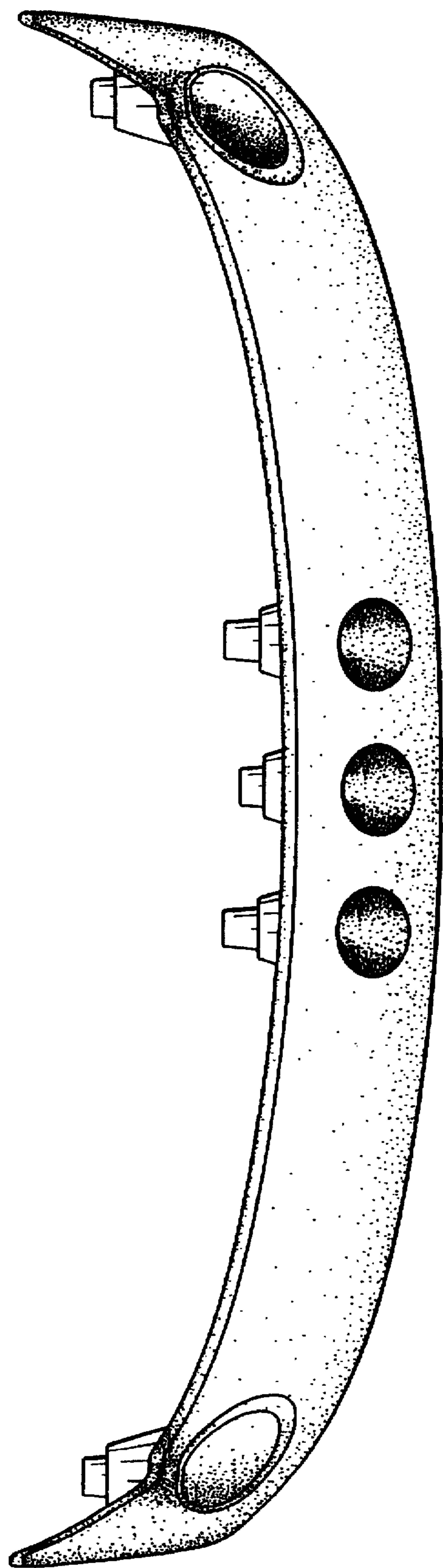
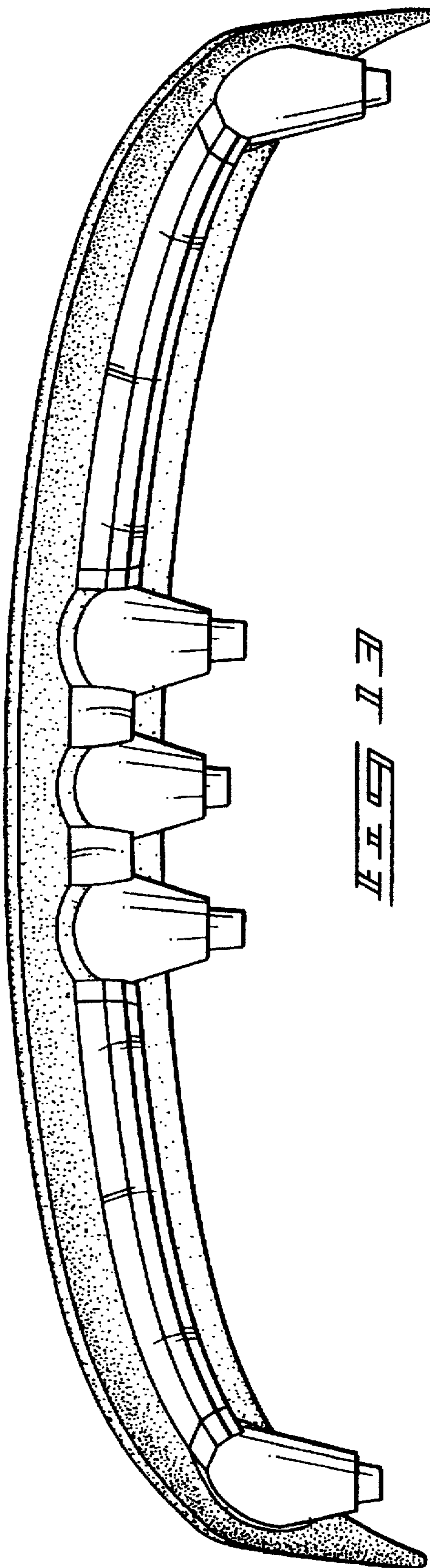

FIG. 2



21



22

UNITED STATES PATENT AND TRADEMARK OFFICE
CERTIFICATE OF CORRECTION

PATENT NO. : Des. 384,019
DATED : September 23, 1997
INVENTOR(S) : Meryman et al.

It is certified that error appears in the above-identified patent and that said Letters Patent is hereby corrected as shown below:

Column 2, line 24, change "side" to --perspective--.

Signed and Sealed this
Twenty-fourth Day of March, 1998

Attest:



BRUCE LEHMAN

Attesting Officer

Commissioner of Patents and Trademarks