



US00D383710S

United States Patent [19]

[11] Patent Number: **Des. 383,710**

Guichard et al.

[45] Date of Patent: ****Sep. 16, 1997**

[54] VEHICLE BODY

[75] Inventors: **Gary D. Guichard; John P. Sgalia**, both of Farmington Hills; **Trevor M. Creed**, West Bloomfield, all of Mich.; **Michael Santoro**, La Costa, Calif.; **Ricardo Z. Aneiros**, Dearborn; **Clyde W. Ney**, Waterford, both of Mich.

[73] Assignee: **Chrysler Corporation**, Auburn Hills, Mich.

[**] Term: **14 Years**

[21] Appl. No.: **53,964**

[22] Filed: **May 2, 1996**

Related U.S. Application Data

[62] Division of Ser. No. 24,426, Jun. 14, 1994, abandoned.

[51] LOC (6) Cl. **12-08**

[52] U.S. Cl. **D12/91**

[58] Field of Search **D12/82-100**

[56] References Cited

U.S. PATENT DOCUMENTS

D. 172,124	5/1954	Blenkle	D12/99 X
D. 220,837	6/1971	Mattson	D12/98
D. 296,538	7/1988	Kim	D12/91

OTHER PUBLICATIONS

Automotive Industries, "Mighty Mite," p. 18, Feb. 1, 1959.
Automotive News, Datsun patrol, p. 254, 1963 Almanac Issue.

Motor Trend, Jeep CJ-7, p. 51, Mar. 1976.

Jeep Catalog, Jeep CJ-5, pp. 6, 7, 9, 1974.

Primary Examiner—Melody N. Brown
Attorney, Agent, or Firm—M. P. Calcaterra

[57] CLAIM

The ornamental design for a vehicle body, as shown and described.

DESCRIPTION

FIG. 1 is a front perspective view of a vehicle body constructed in accordance to the teachings of a first embodiment of the present invention, it being understood that the hidden line showing throughout the drawings is for illustrative purposes only and accordingly forms no part of the subject invention;

FIG. 2 is a rear perspective view of the vehicle body shown in FIG. 1;

FIG. 3 is a side view of the vehicle body shown in FIG. 1, it being understood that the opposite side to that shown is a substantial mirror image thereof;

FIG. 4 is an elevated front view of the vehicle body shown in FIG. 1;

FIG. 5 is a front view of the vehicle body shown in FIG. 1; and,

FIG. 6 is a rear view of the vehicle body shown in FIG. 1.

1 Claim, 5 Drawing Sheets

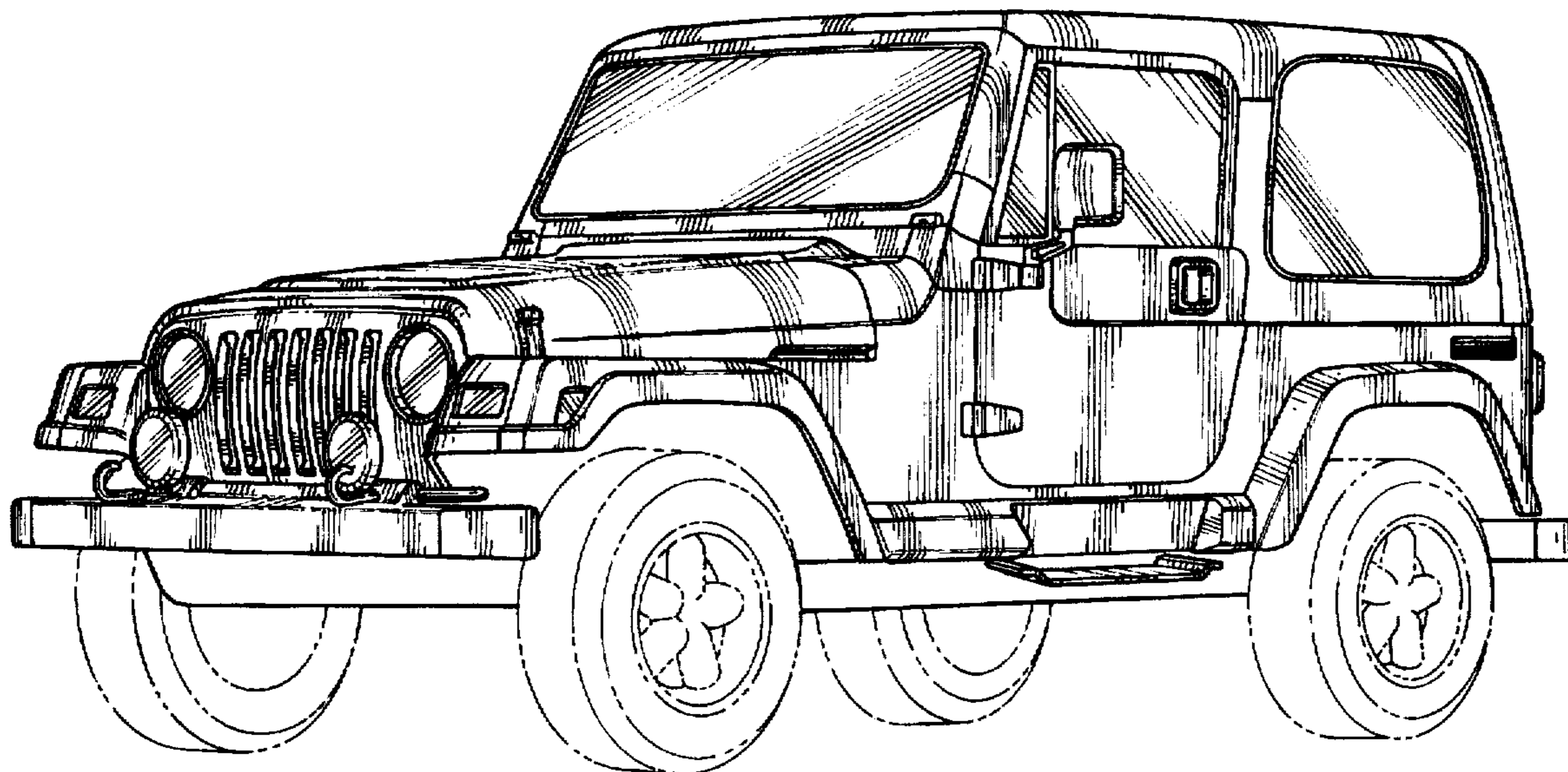

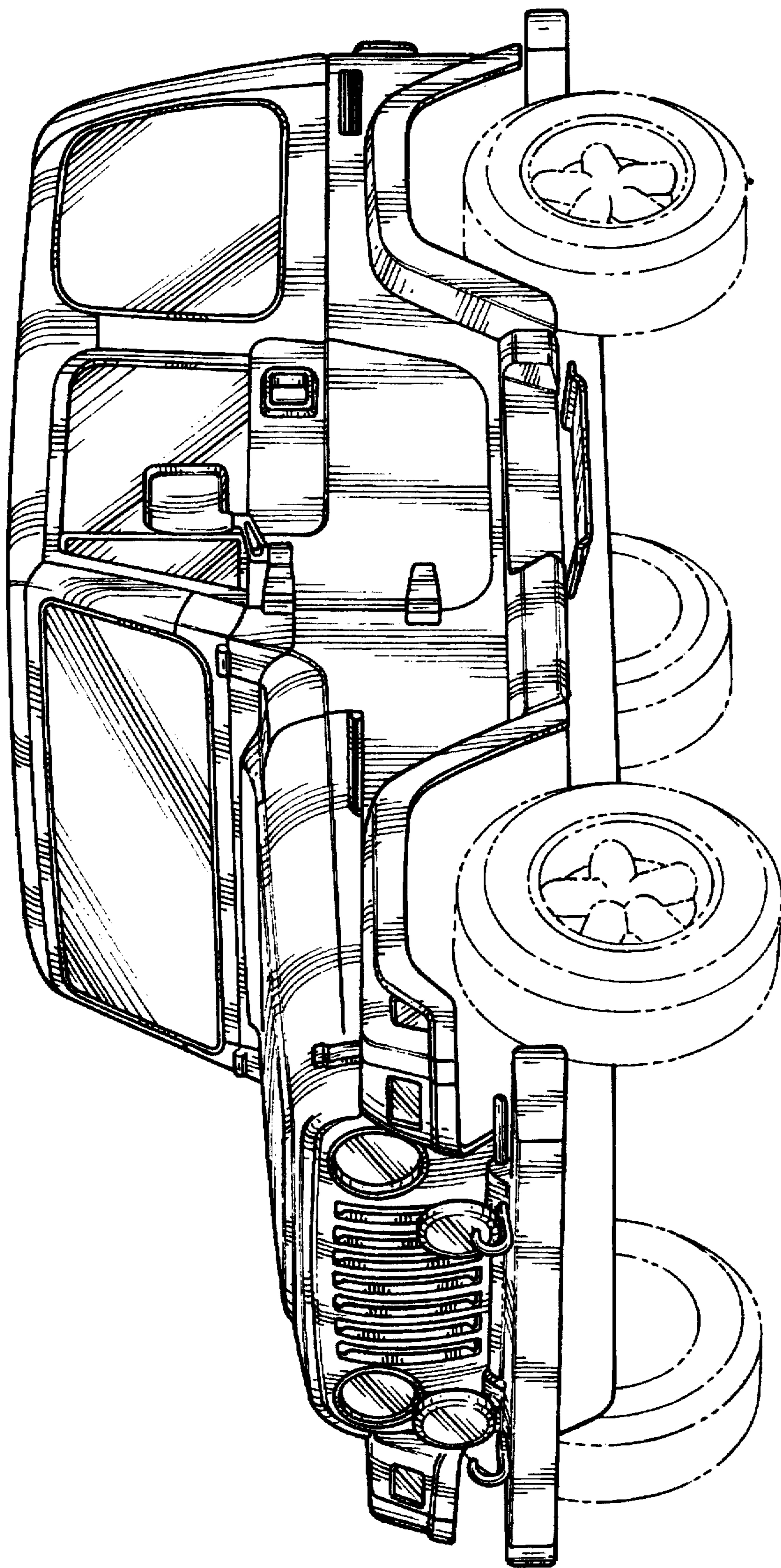

Fig - 1

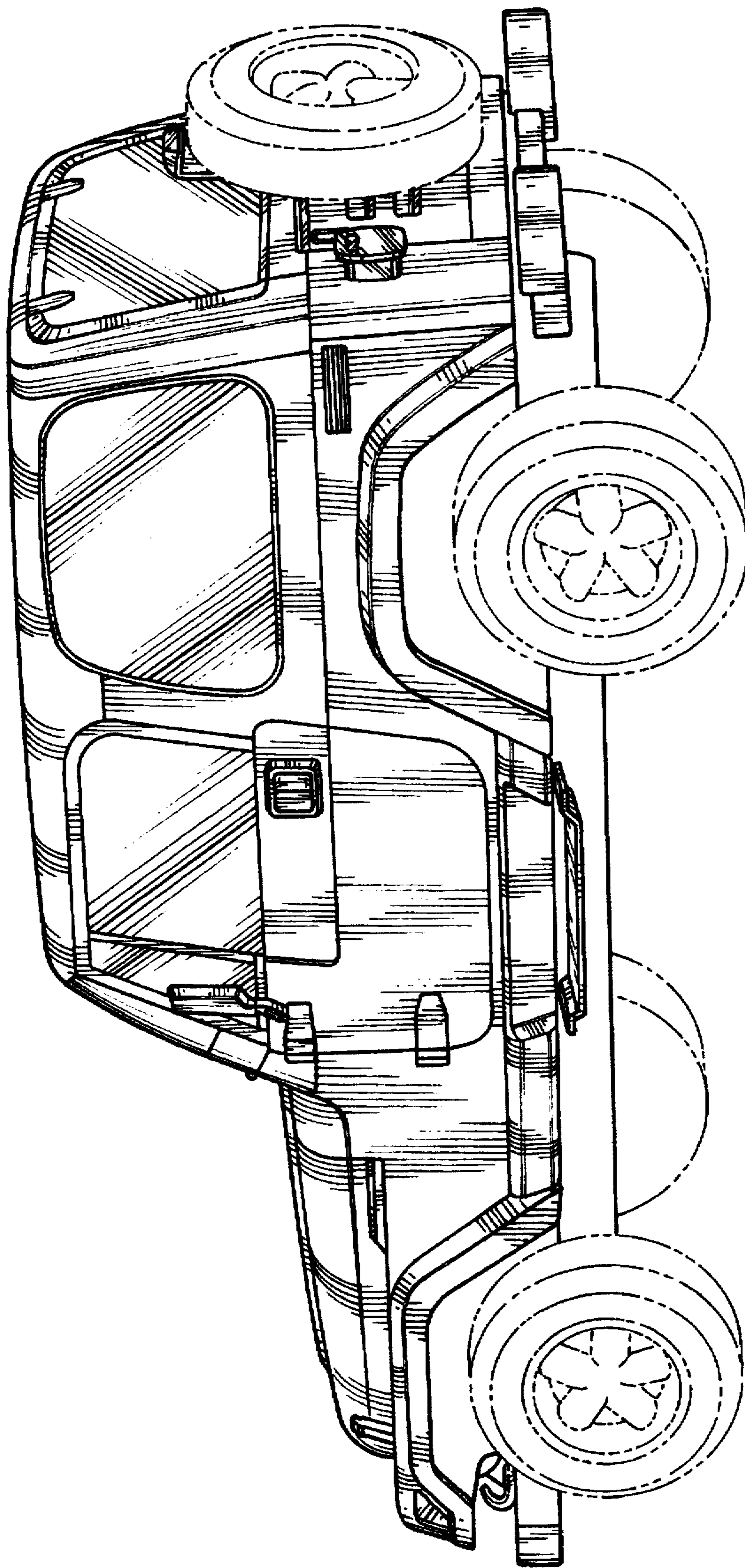

Fig - 2

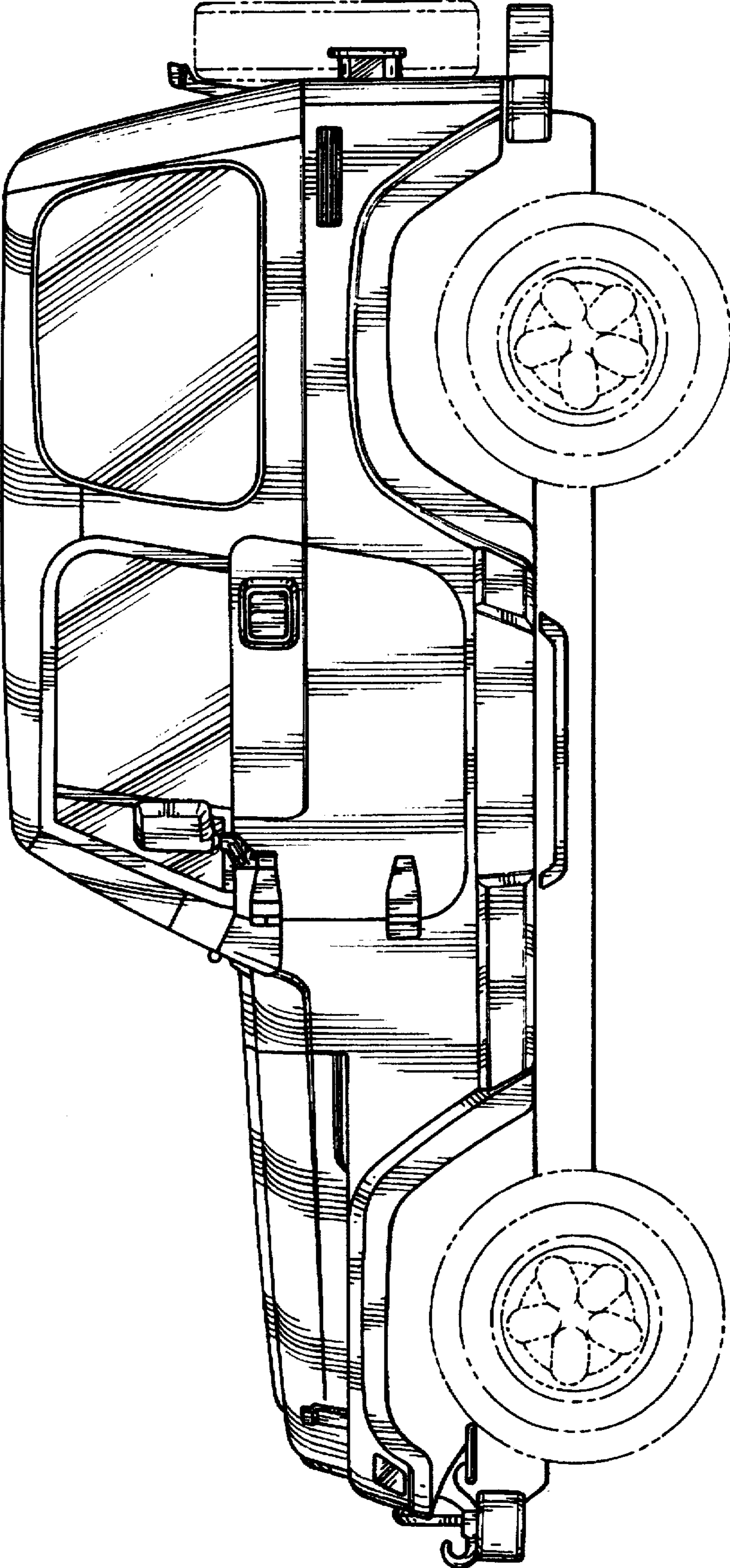

Fig - 3

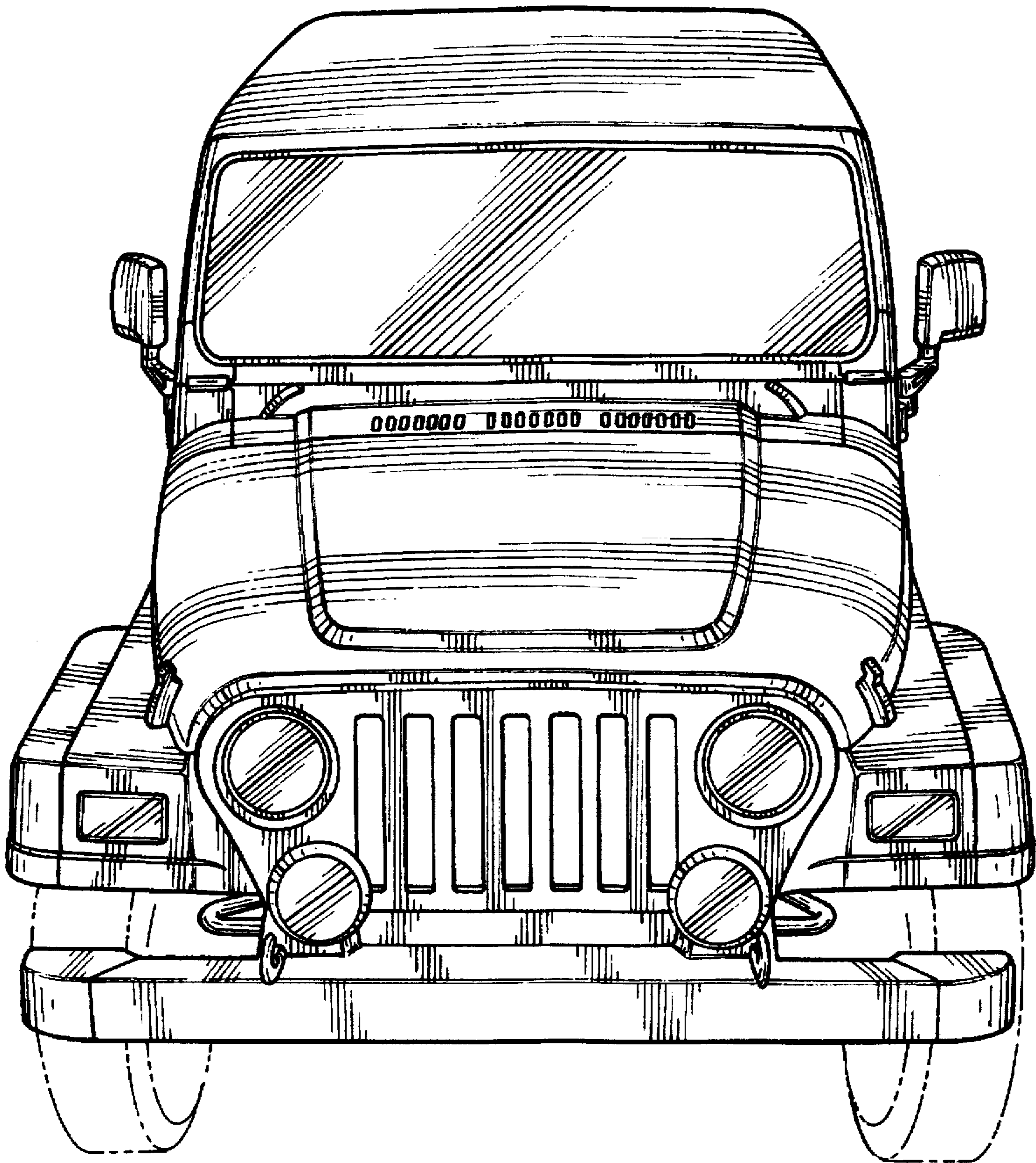

Fig - 4

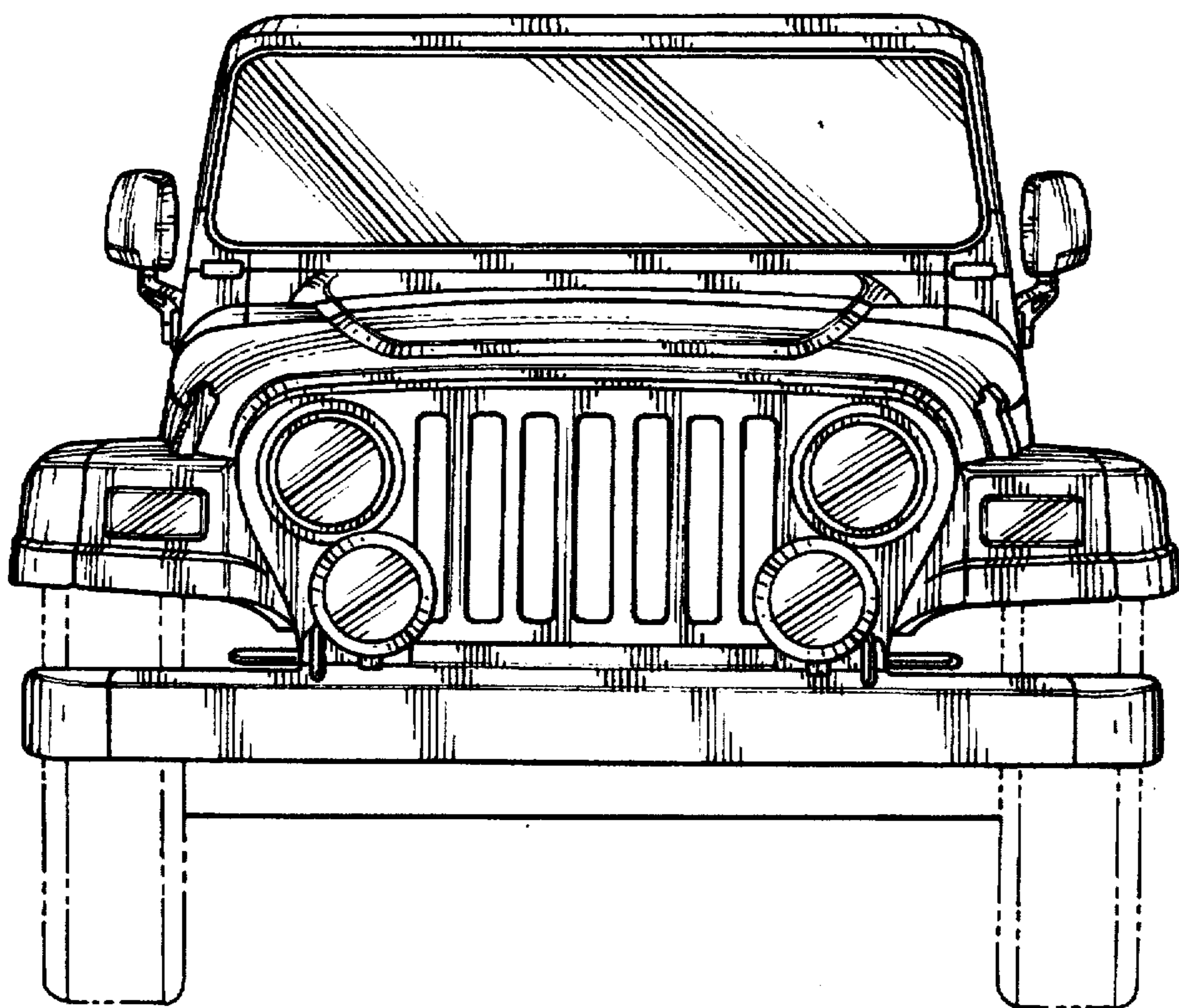

Fig - 5

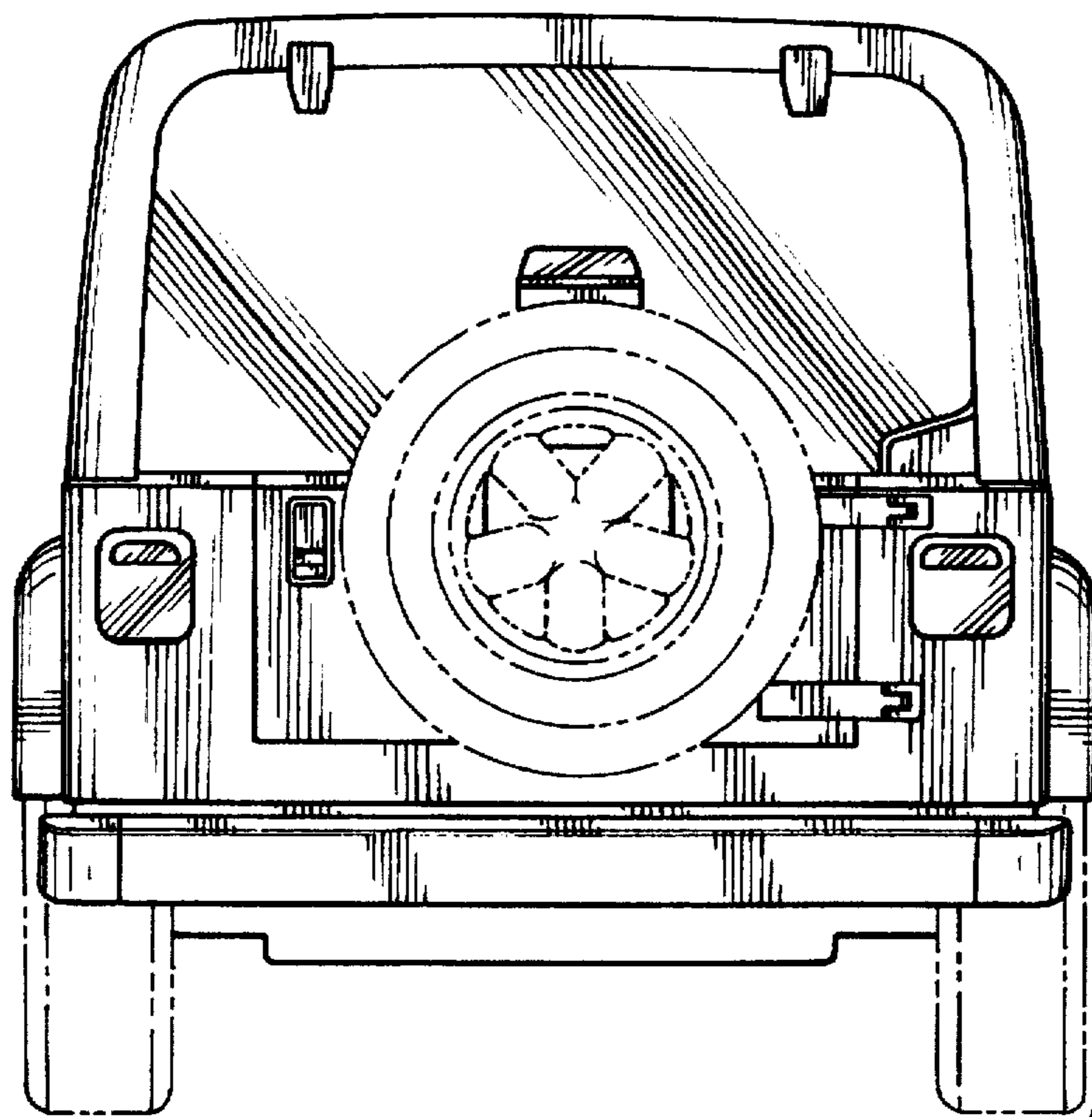

Fig - 6