



US00D383572S

**United States Patent** [19]  
**Rea**

[11] **Patent Number:** **Des. 383,572**  
[45] **Date of Patent:** **\*\*Sep. 9, 1997**

[54] **STIRRUP**

[75] **Inventor:** **Philip Leslie Rea**, London, Great Britain

[73] **Assignee:** **Precision Riding Limited**, Cheshire, United Kingdom

[\*\*] **Term:** **14 Years**

[21] **Appl. No.:** **48,719**

[22] **Filed:** **Jan. 11, 1996**

[30] **Foreign Application Priority Data**

Jul. 11, 1995 [GB] United Kingdom ..... 2048733

[51] **LOC (6) Cl.** ..... **30-04**

[52] **U.S. Cl.** ..... **D30/142**

[58] **Field of Search** ..... 54/47, 49.5; D30/142, D30/134-138

[56] **References Cited**

**U.S. PATENT DOCUMENTS**

- D. 20,746 5/1891 Moulton ..... D30/142
- D. 339,665 9/1993 Nishimoula ..... D30/142
- 3,910,015 10/1975 Ebejer ..... 54/49

**FOREIGN PATENT DOCUMENTS**

62109/90 3/1991 Australia .

|         |         |                      |       |
|---------|---------|----------------------|-------|
| 25481   | 7/1883  | Germany .....        | 54/47 |
| 427793  | 8/1911  | Germany .....        | 54/47 |
| 1560465 | 4/1990  | U.S.S.R. .           |       |
| 22951   | 10/1907 | United Kingdom ..... | 54/47 |
| 216332  | 5/1924  | United Kingdom ..... | 54/47 |
| 1131665 | 10/1968 | United Kingdom .     |       |

**OTHER PUBLICATIONS**

Scheffer & Rossum Co., 1915 Catalog No. 14 of Harness & Saddlery Hardware; p. 447; Men's Malleable Iron Stirrup. Article: "Baffled by Tack?", 3p.; Mar. 1994; 'Peacock' Safety Stirrup & SIRRUP in Diagram 1.

*Primary Examiner*—Cathy Anne MacCormac  
*Attorney, Agent, or Firm*—Larson and Taylor

[57] **CLAIM**

The ornamental design for a stirrup, as shown and described.

**DESCRIPTION**

FIG. 1 is a front elevational view of a stirrup showing my new design, with the rear view being identical;  
FIG. 2 is a right side elevational view thereof, the other side being identical;  
FIG. 3 is a top plan view thereof; and,  
FIG. 4 is a bottom plan view thereof.

**1 Claim, 2 Drawing Sheets**

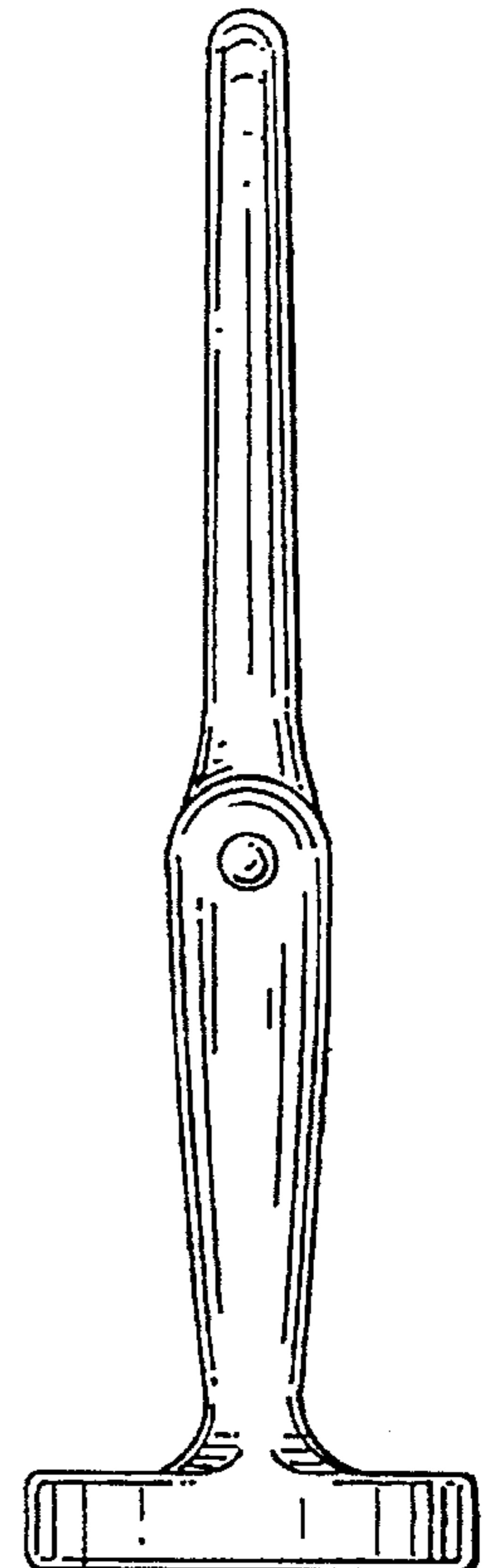
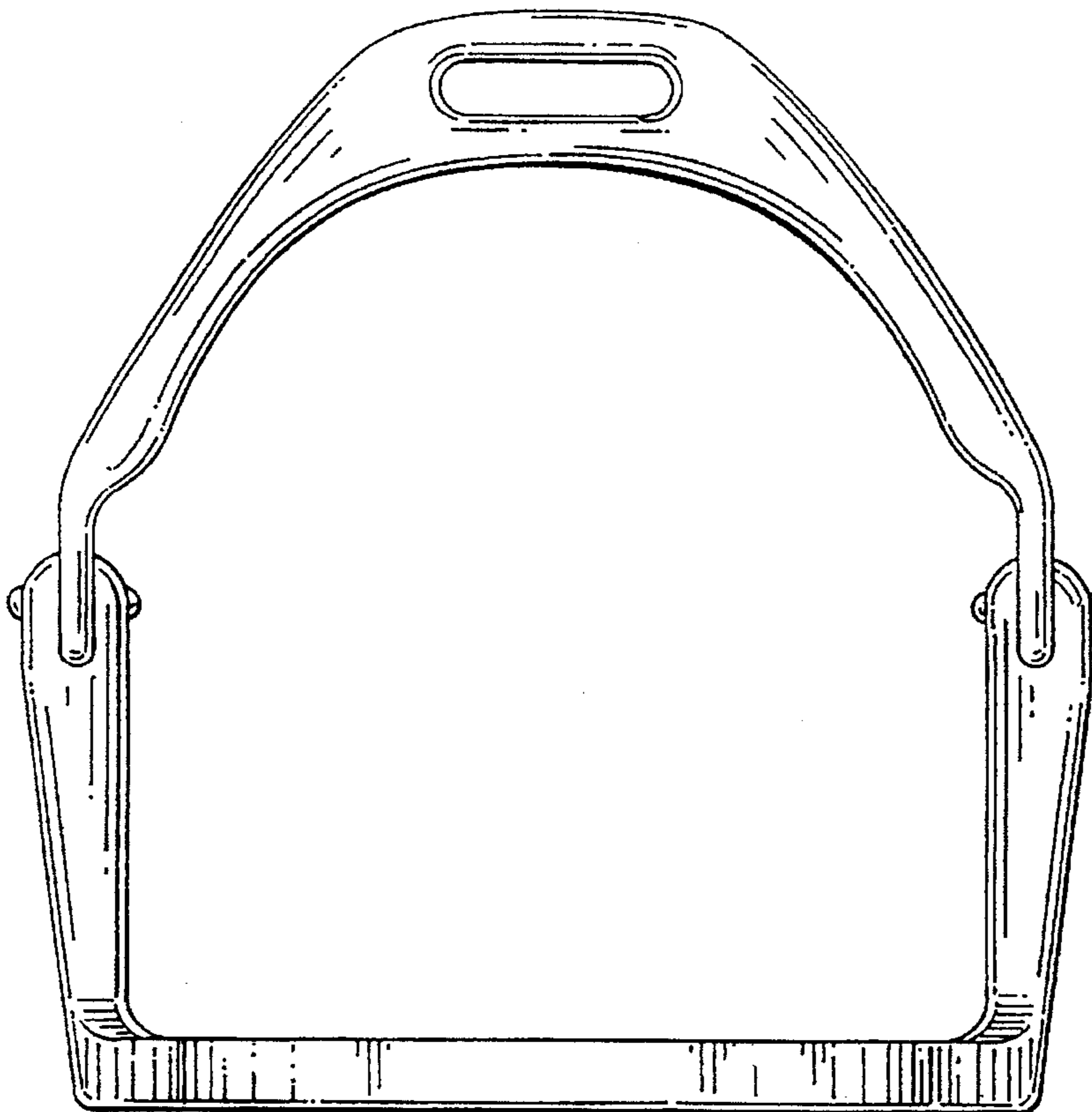

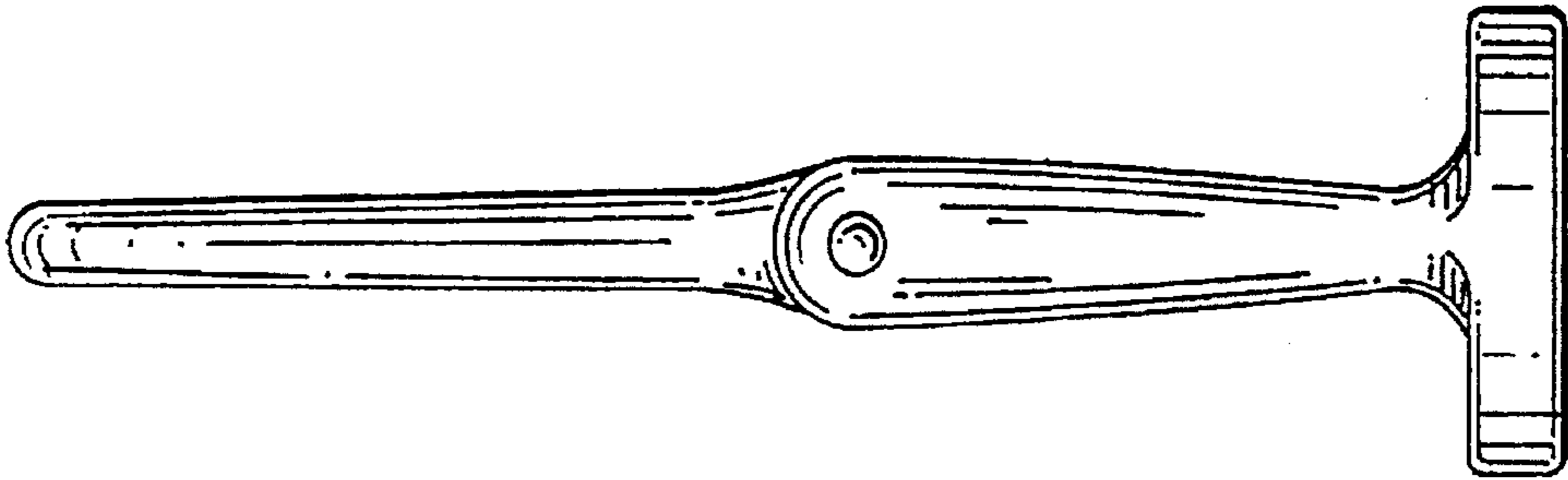

FIG. 2

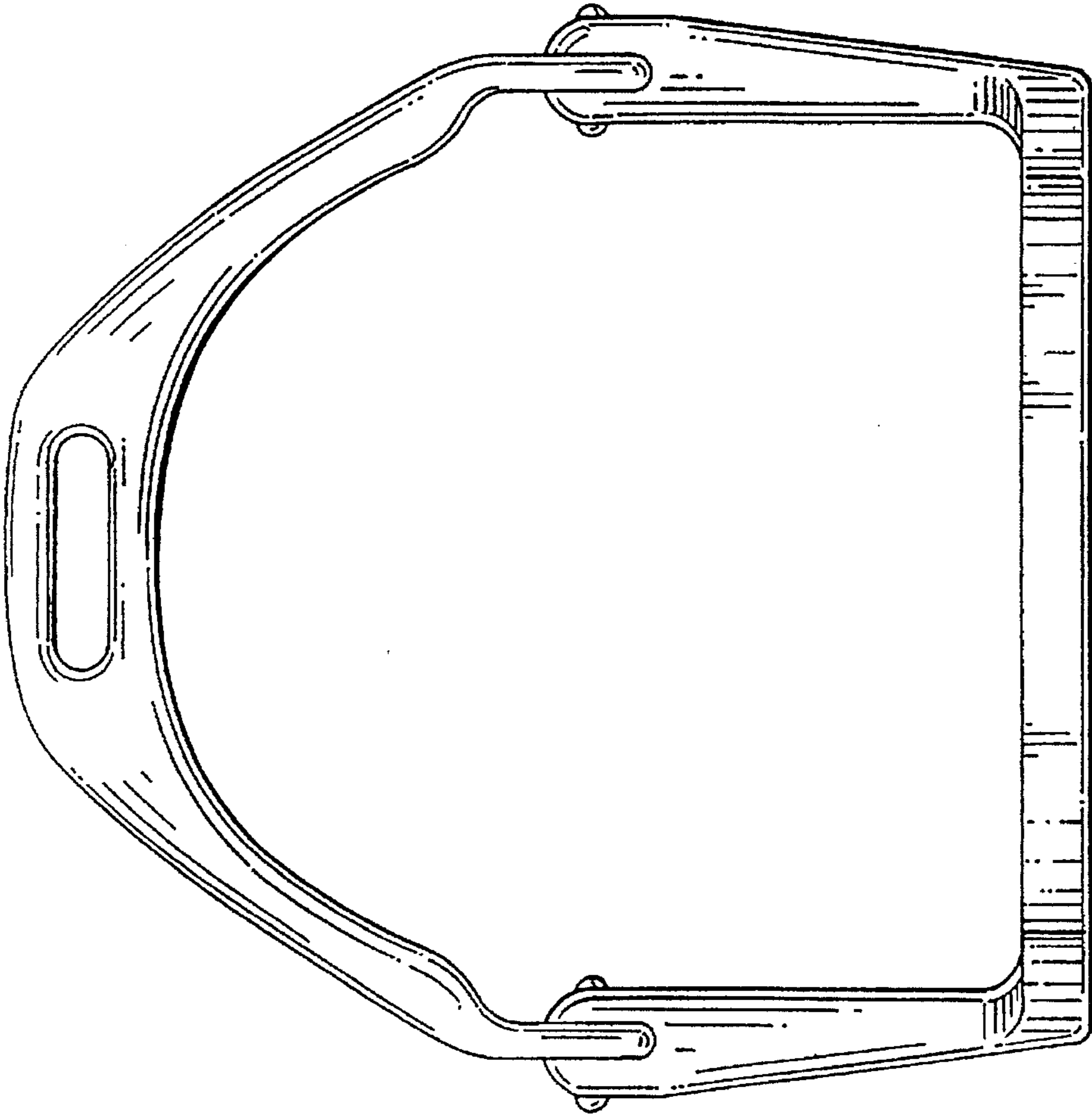

FIG. 1

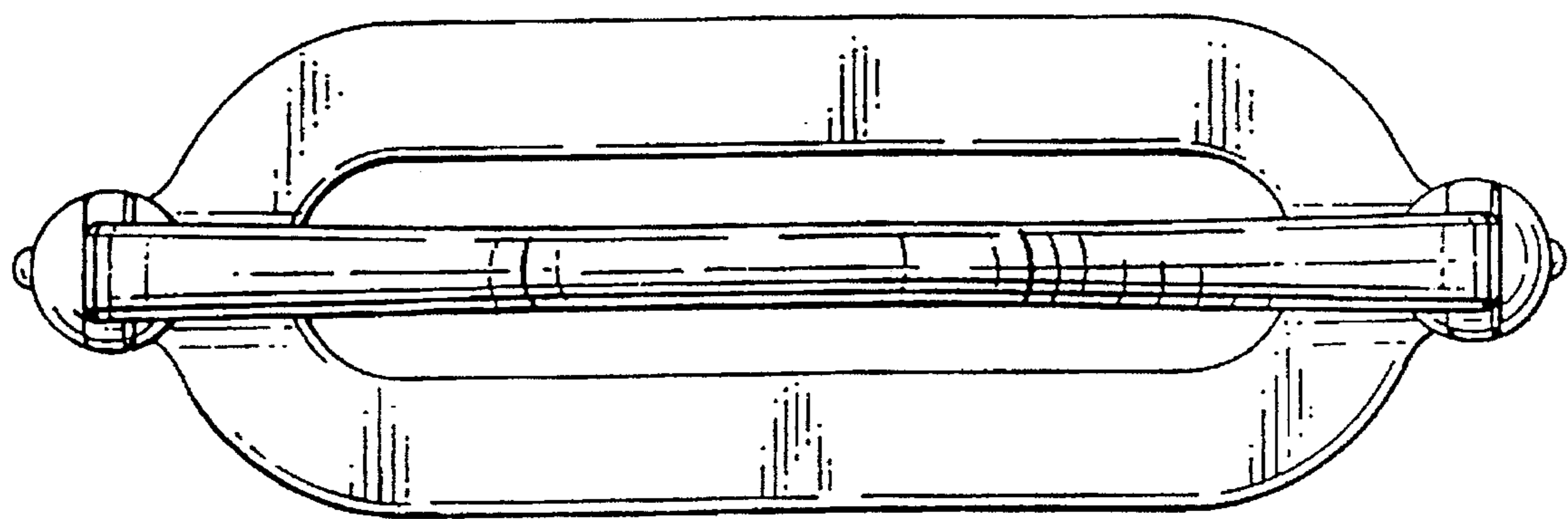

FIG. 3

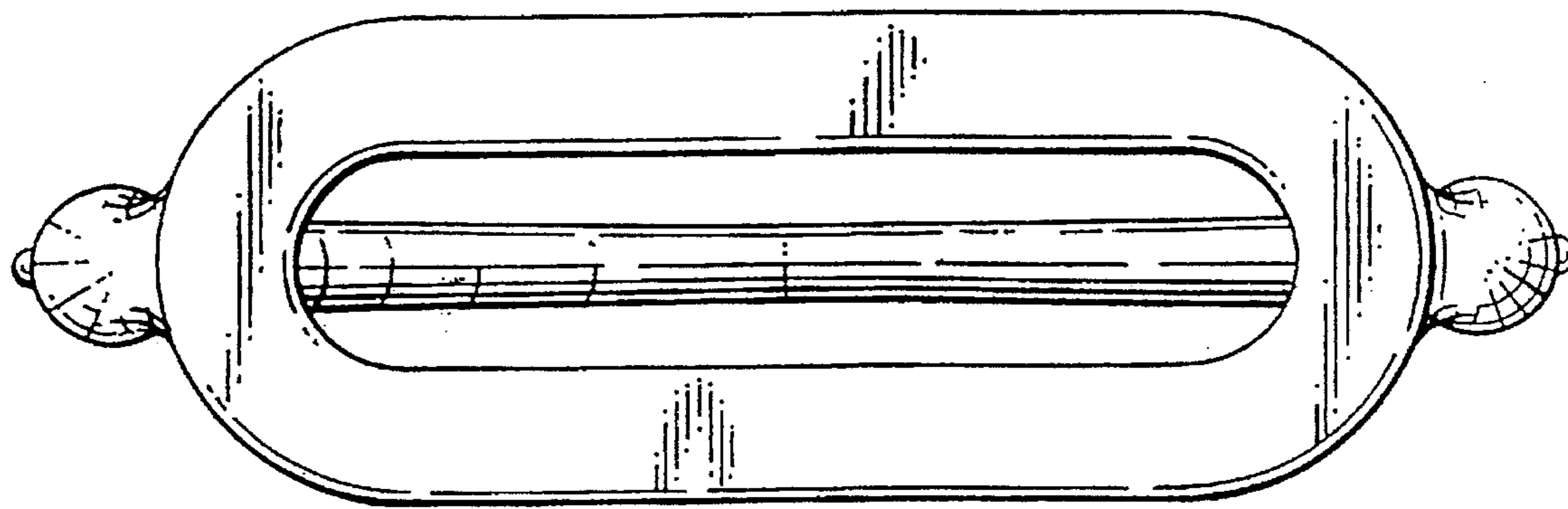

FIG. 4