



US00D383468S

United States Patent [19]

[11] Patent Number: **Des. 383,468**

Buckingham et al.

[45] Date of Patent: ****Sep. 9, 1997**

[54] **CONTROL PANEL FOR AN AUTOMOTIVE RADIO/CASSETTE**

[75] Inventors: **Thomas John Buckingham**, Allen Park, Mich.; **Gary Arthur Goodman**, Clayhall; **Clifford Thomas Pickering**, Stock, both of England

[73] Assignee: **Ford Motor Company**, Dearborn, Mich.

[**] Term: **14 Years**

[21] Appl. No.: **50,242**

[22] Filed: **Feb. 12, 1996**

[51] LOC (6) Cl. **19-03**

[52] U.S. Cl. **D14/258**

[58] **Field of Search** D14/124, 154-159, D14/188, 257, 258; 455/89-90, 346-349

[56] **References Cited**

U.S. PATENT DOCUMENTS

- D. 333,307 2/1993 Sliper et al. .
- D. 334,572 4/1993 Gauthier et al. .
- D. 343,842 2/1994 Fowler et al. D14/258
- D. 350,964 9/1994 Fowler et al. D14/157 X
- D. 354,962 1/1995 Jazanowski et al. D14/258
- D. 356,093 3/1995 McCauley et al. D14/157 X

Primary Examiner—James Gandy
Assistant Examiner—Cathron B. Matta
Attorney, Agent, or Firm—Mark Mollon

[57] **CLAIM**

The ornamental design for a control panel for an automotive radio/cassette, as shown and described.

DESCRIPTION

FIG. 1 is a front, top, and left side perspective view of a control panel for an automotive radio/cassette showing our new design, and in particular showing a control panel having a removable group of buttons for anti-theft purposes; FIG. 2 is a left side elevational view thereof; FIG. 3 is a right side elevational view thereof; FIG. 4 is a top view thereof; FIG. 5 is a front elevational view thereof; FIG. 6 is a bottom view thereof; FIG. 7 is a front, top, and left side perspective view of a control panel for an automotive radio/cassette showing a second embodiment of our new design, and in particular showing a control panel without any removable group of buttons; FIG. 8 is a left side elevational view thereof; FIG. 9 is a right side elevational view thereof; FIG. 10 is a top view thereof; FIG. 11 is a front elevational view thereof; and, FIG. 12 is a bottom view thereof.

1 Claim, 4 Drawing Sheets

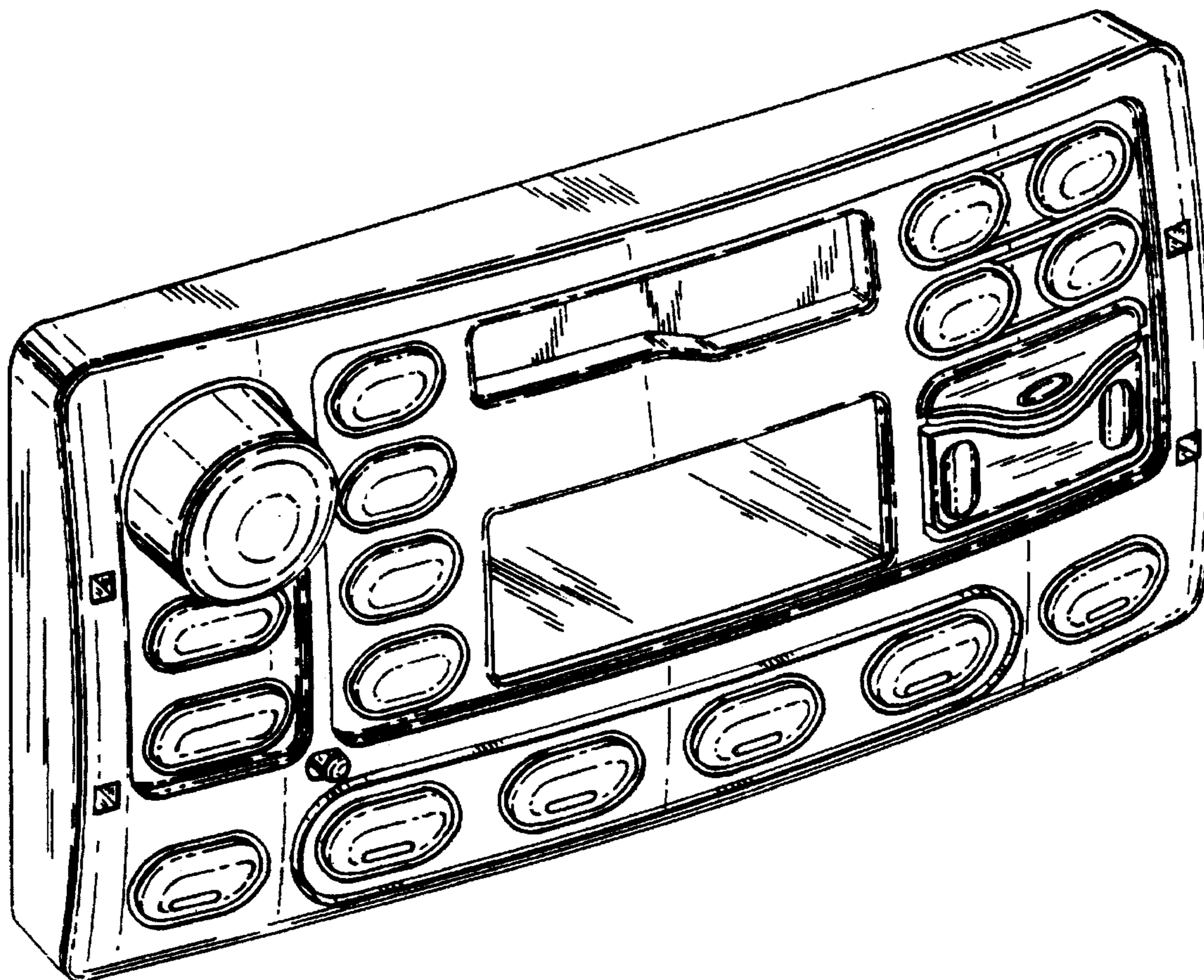

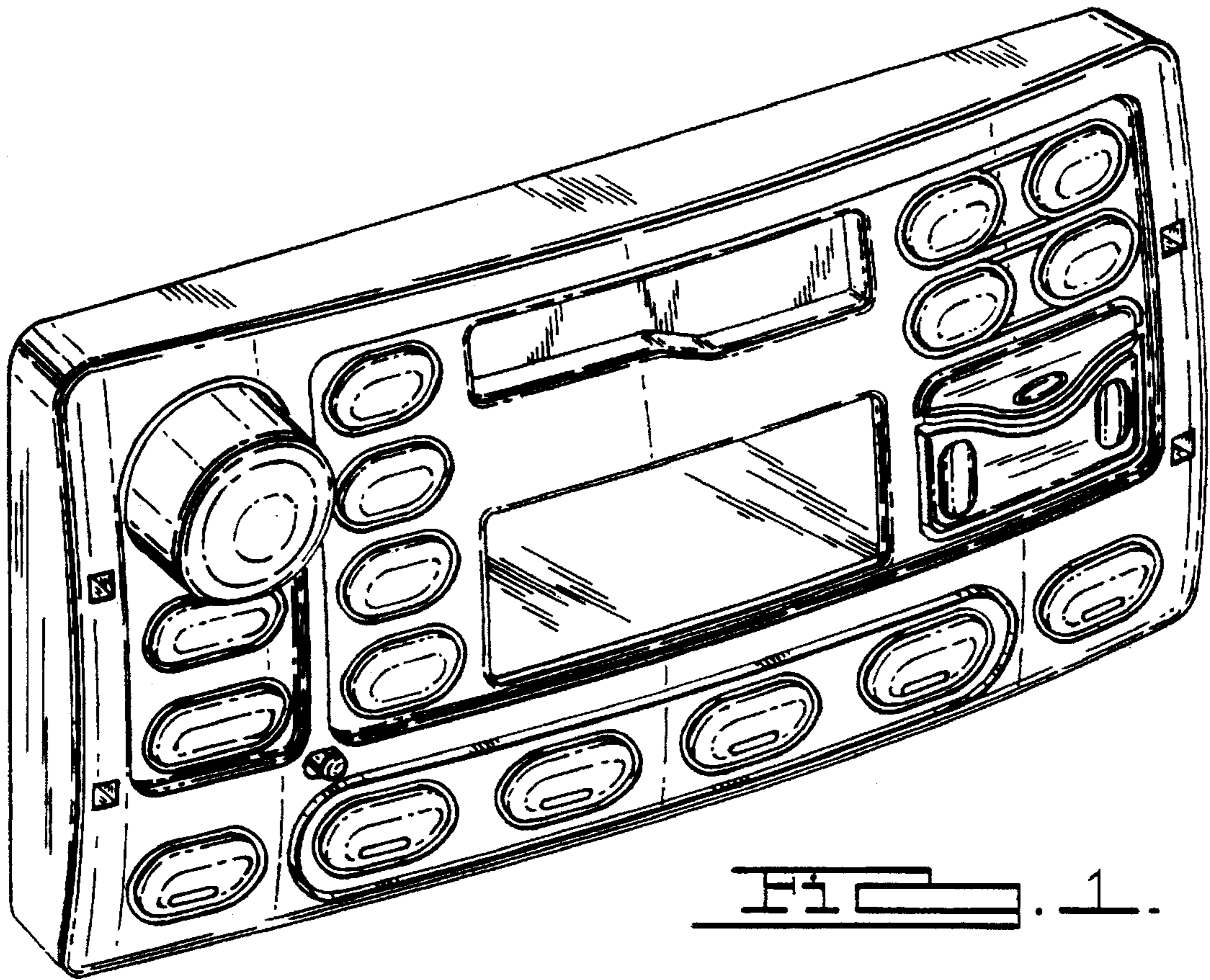

FIG. 1.

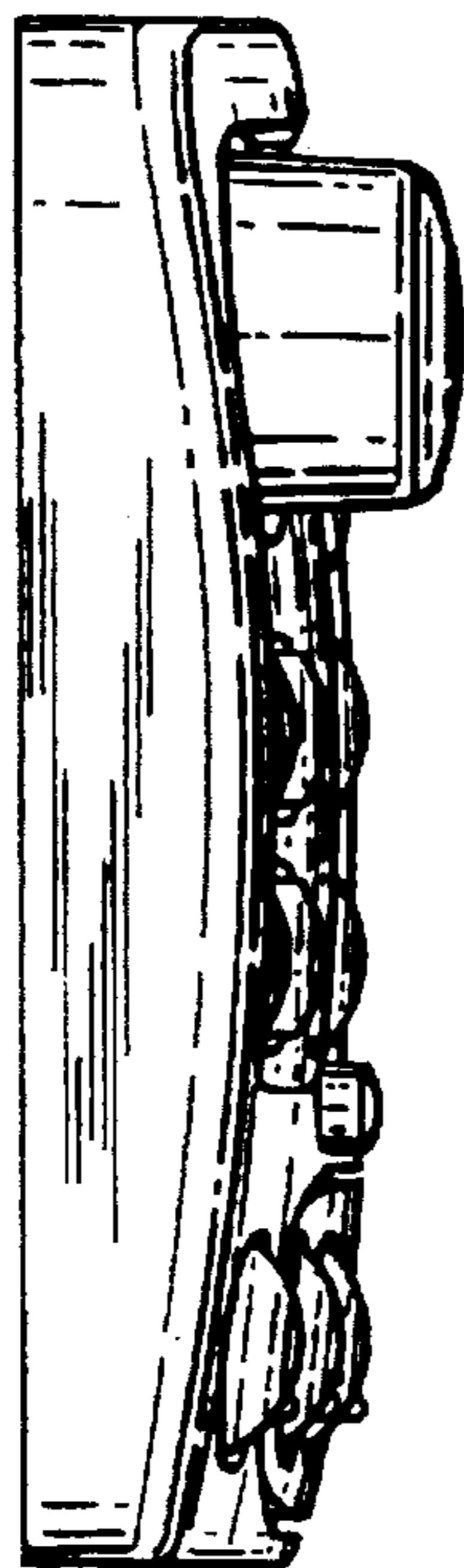

FIG. 2.

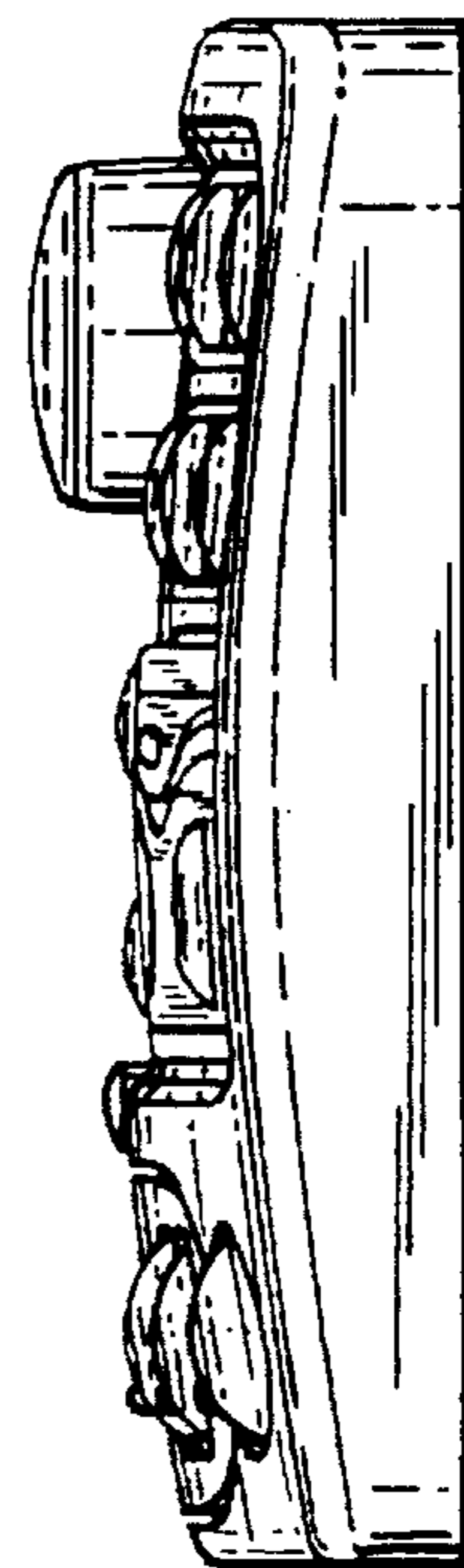

FIG. 3.



FIG. 4.

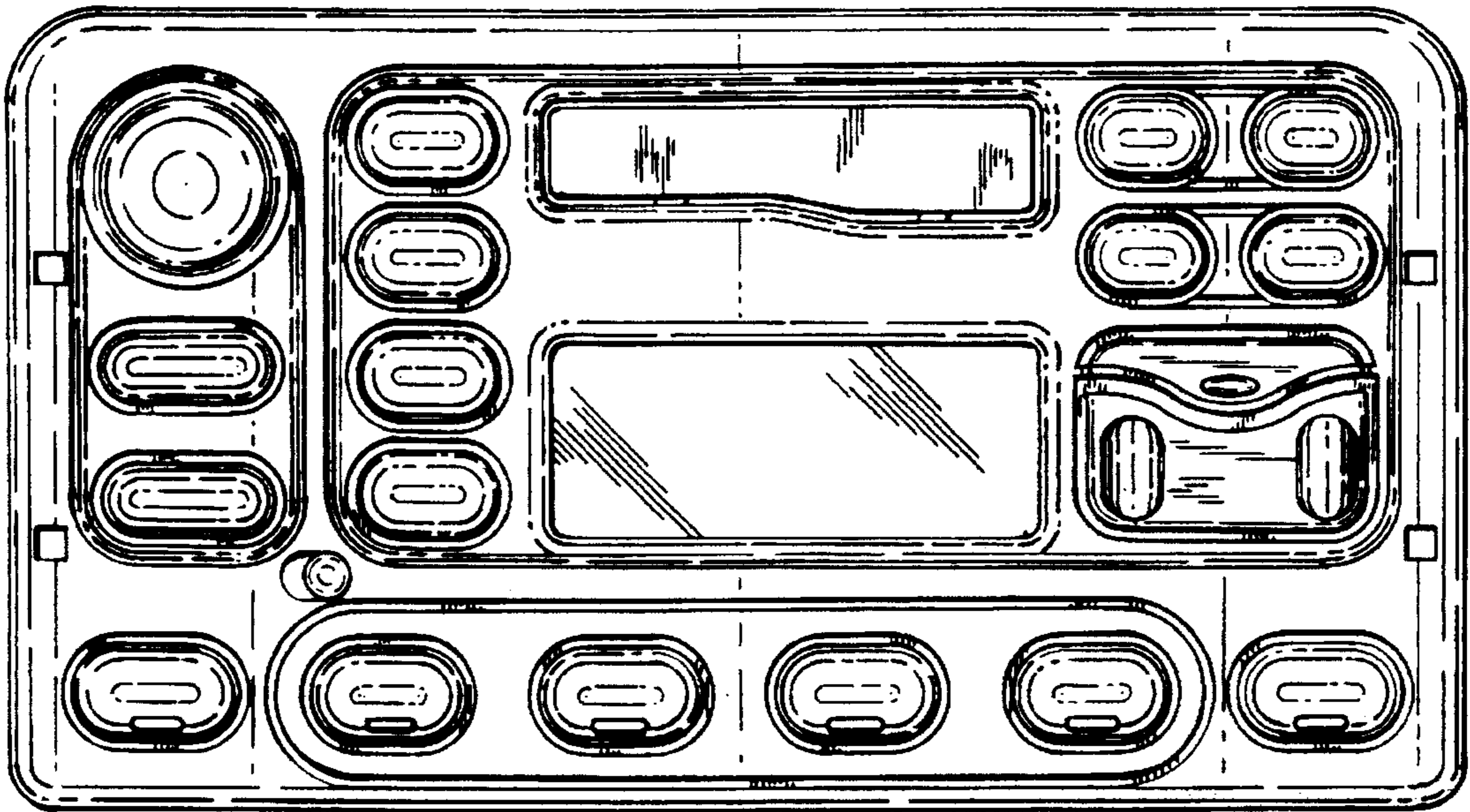

FIG. 5.



FIG. 6.

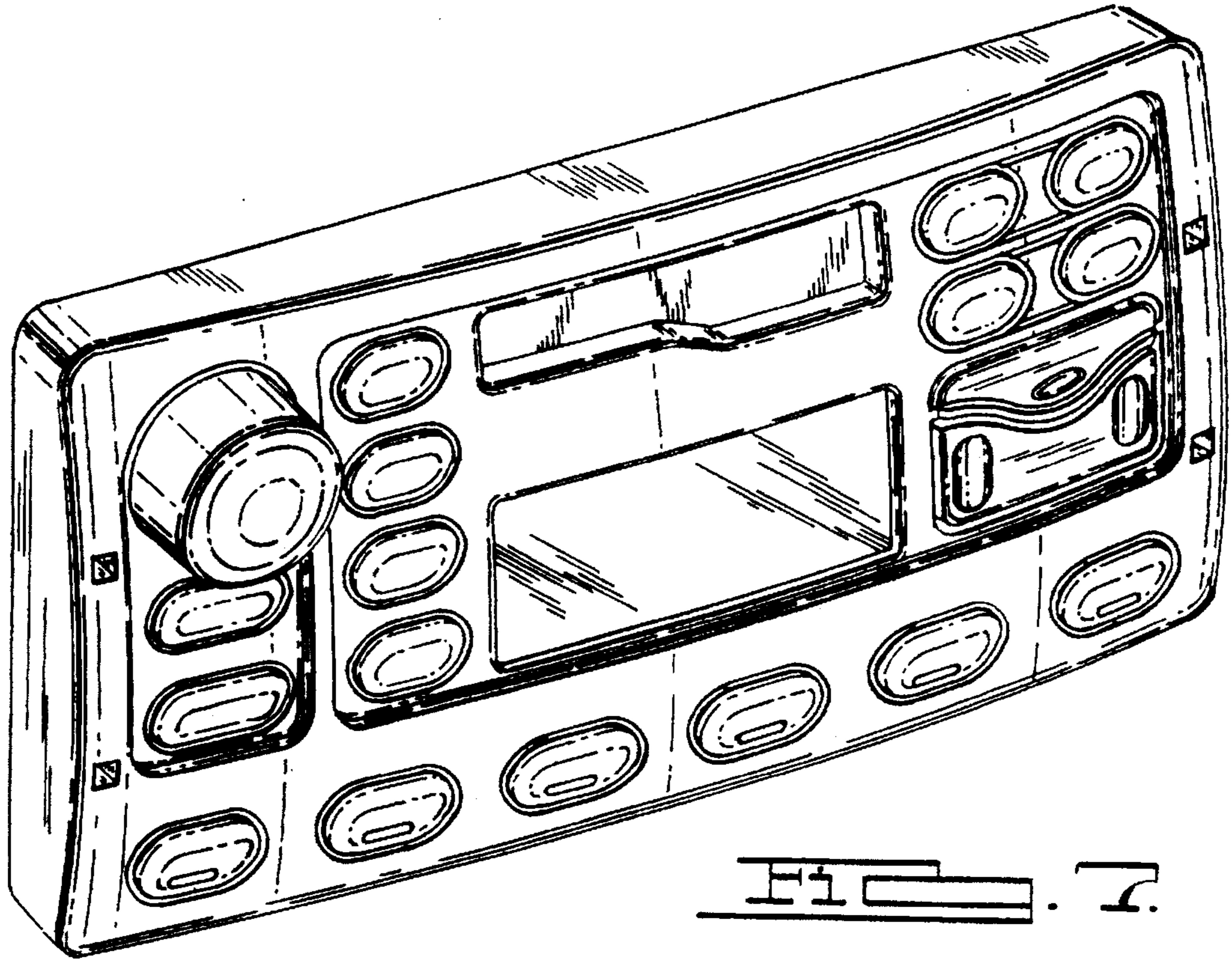

FIG. 7.

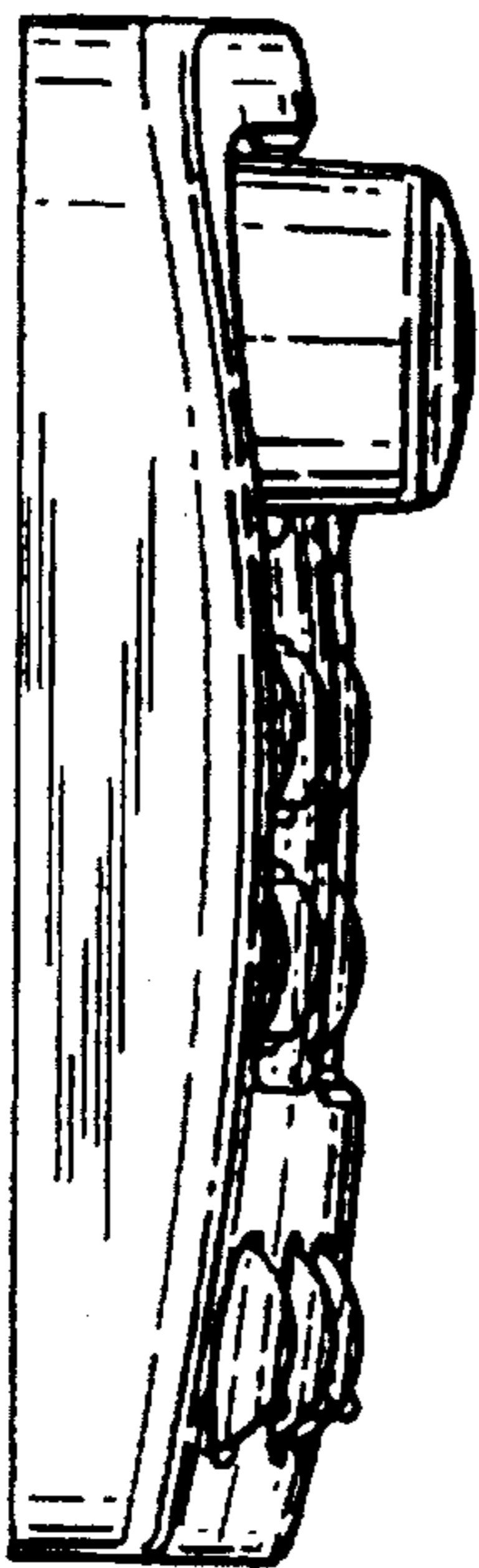

FIG. 8.

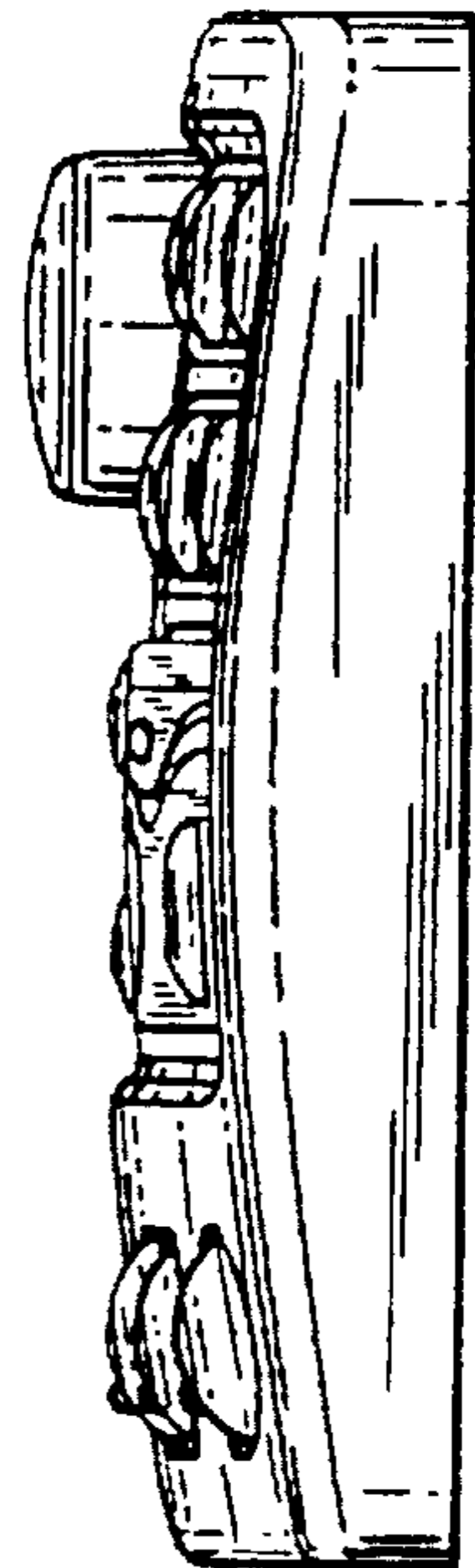

FIG. 9.

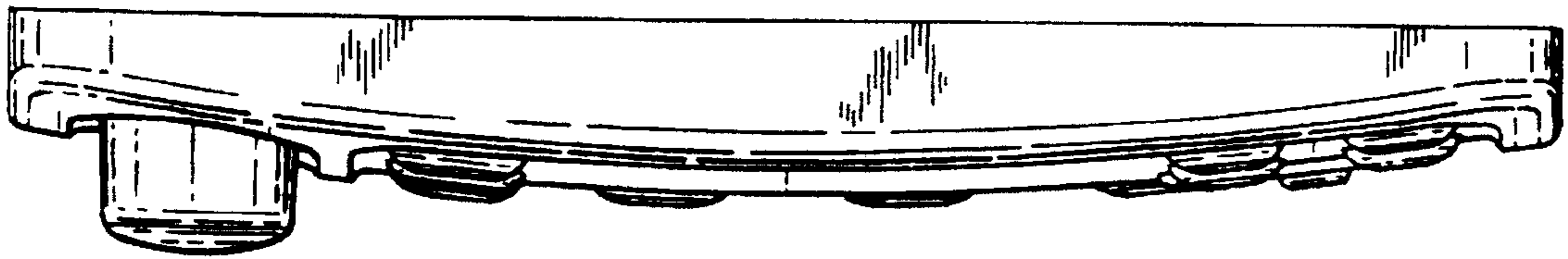

FIG. 10.

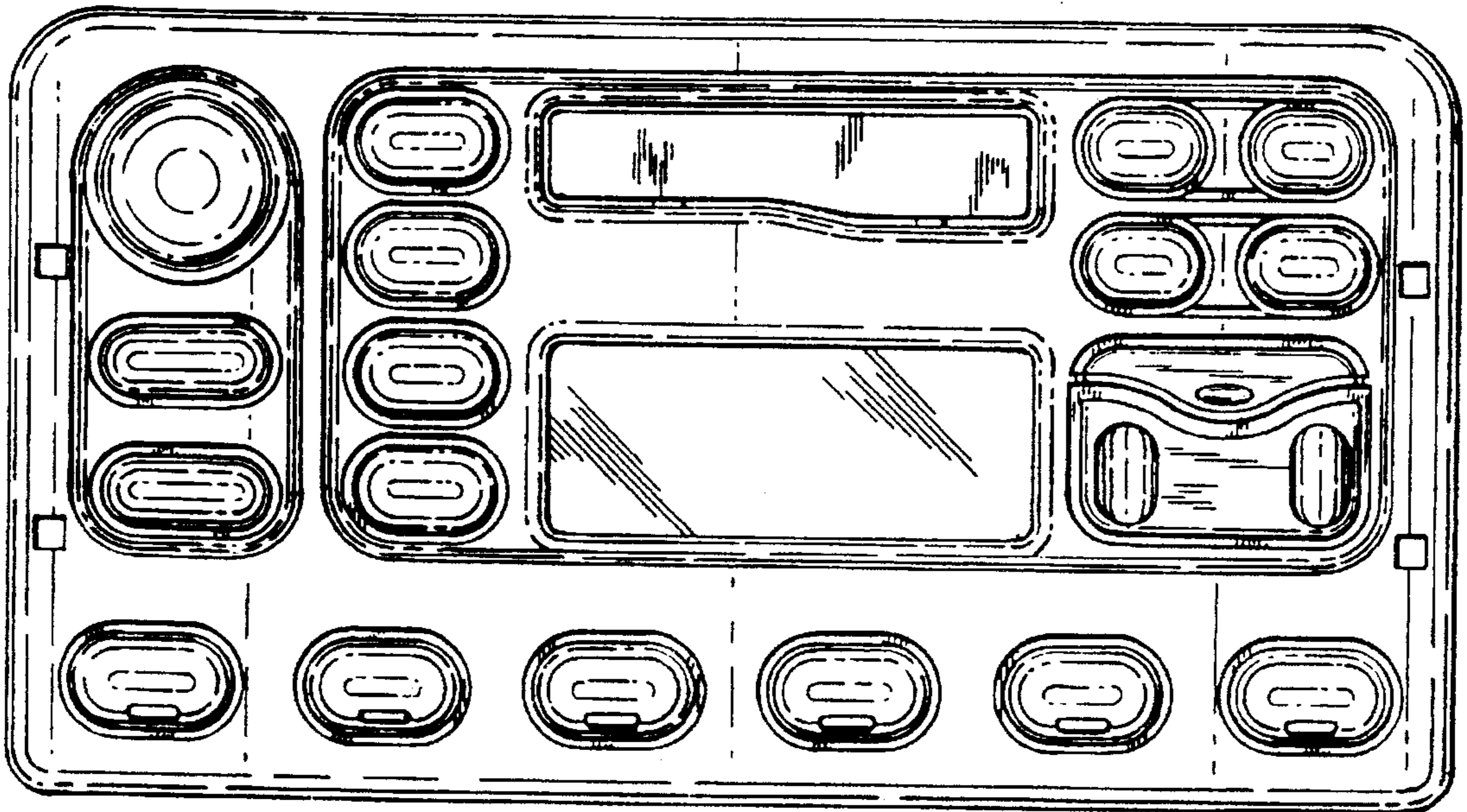

FIG. 11.

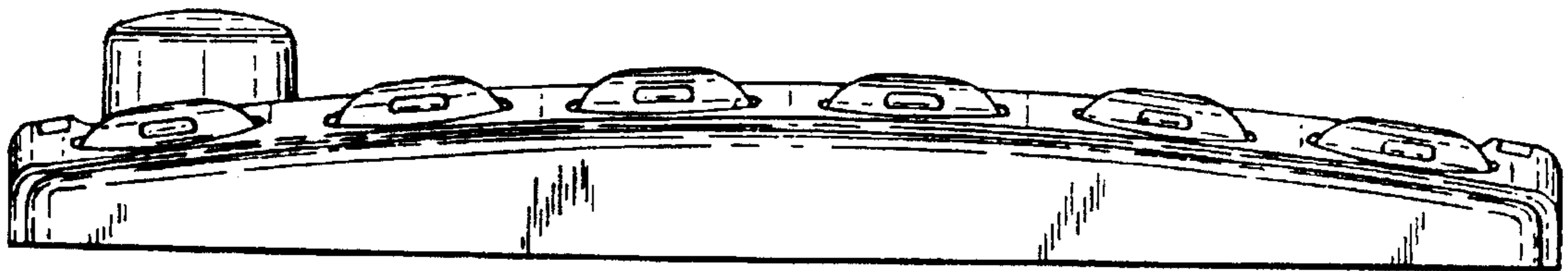

FIG. 12.