



US00D383333S

United States Patent [19]
Mechem, Jr.

[11] **Patent Number:** **Des. 383,333**
[45] **Date of Patent:** ****Sep. 9, 1997**

[54] **STAND FOR MUSICAL INSTRUMENT**

4,917,341 4/1990 Pirchio 248/164
5,467,953 11/1995 Malizia 248/166

[75] **Inventor:** **Larry J. Mechem, Jr., Anderson, Ind.**

Primary Examiner—B. J. Bullock

[73] **Assignee:** **Standtastic, Anderson, Ind.**

Assistant Examiner—Linda Brooks

[**] **Term:** **14 Years**

Attorney, Agent, or Firm—Woodard, Emhardt, Naughton, Moriarty & McNett

[21] **Appl. No.:** **50,819**

[57] **CLAIM**

[22] **Filed:** **Feb. 27, 1996**

The ornamental design for a stand for musical instrument, as shown and described.

[51] **LOC (6) Cl.** **06-06**

DESCRIPTION

[52] **U.S. Cl.** **D6/462; D6/466; D17/99**

FIG. 1 is a front elevational view of a stand for a musical instrument, showing a typical embodiment of my new design;

[58] **Field of Search** D6/429, 461-469,

D6/449, 457, 458, 459; 84/327, 280; 248/164,

175, 371, 165, 176.1, 129, 166, 167, 150,

152, 443, 450-452, 469, 473, 441.1, 146,

174, 465.1, 454, 456, 188.1, 188.2, 188.7;

211/13, 34, 43, 37, 38, 106, 133, 195, 181,

85, 42; 108/118, 119

FIG. 2 is a rear elevational view thereof;

FIG. 3 is an enlarged left-side elevational view thereof;

FIG. 4 is a top plan view of FIG. 3;

FIG. 5 is a bottom view of FIG. 3;

FIG. 6 is a further enlarged rear elevational view of my design shown in a folded position; and,

FIG. 7 is a top plan view of FIG. 6.

The appearance of the right side elevational view is a mirror image of the left side elevational view of FIG. 3. The broken line illustration of a keyboard in FIGS. 2 and 3 is for illustrative purposes only and forms no part of the claimed design.

[56] **References Cited**

U.S. PATENT DOCUMENTS

D. 190,309	5/1961	Lorenson	D6/462
398,886	3/1889	Faries	211/181 X
4,541,597	9/1985	Davanture	248/167
4,763,865	8/1988	Danner	248/164

1 Claim, 7 Drawing Sheets

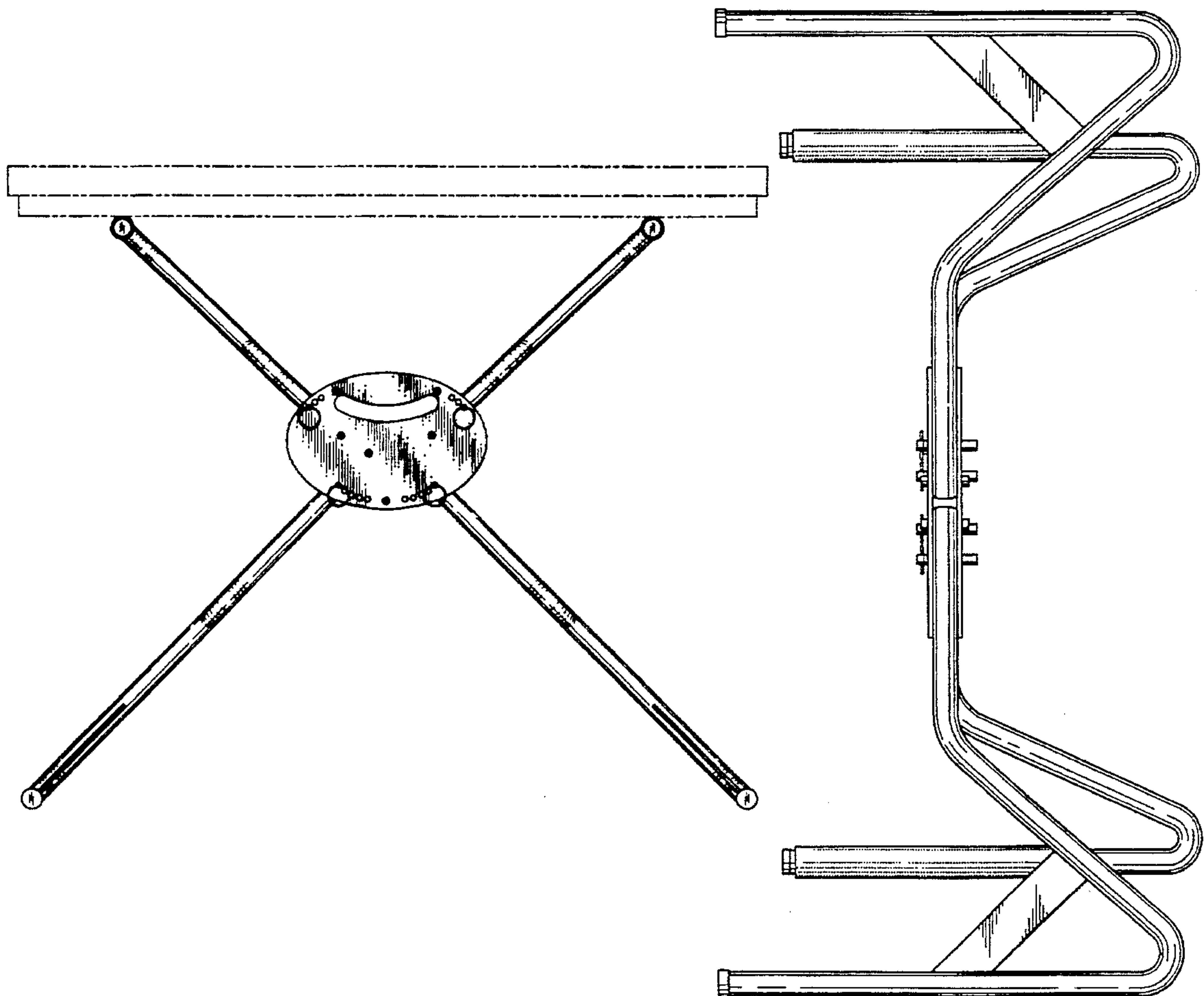

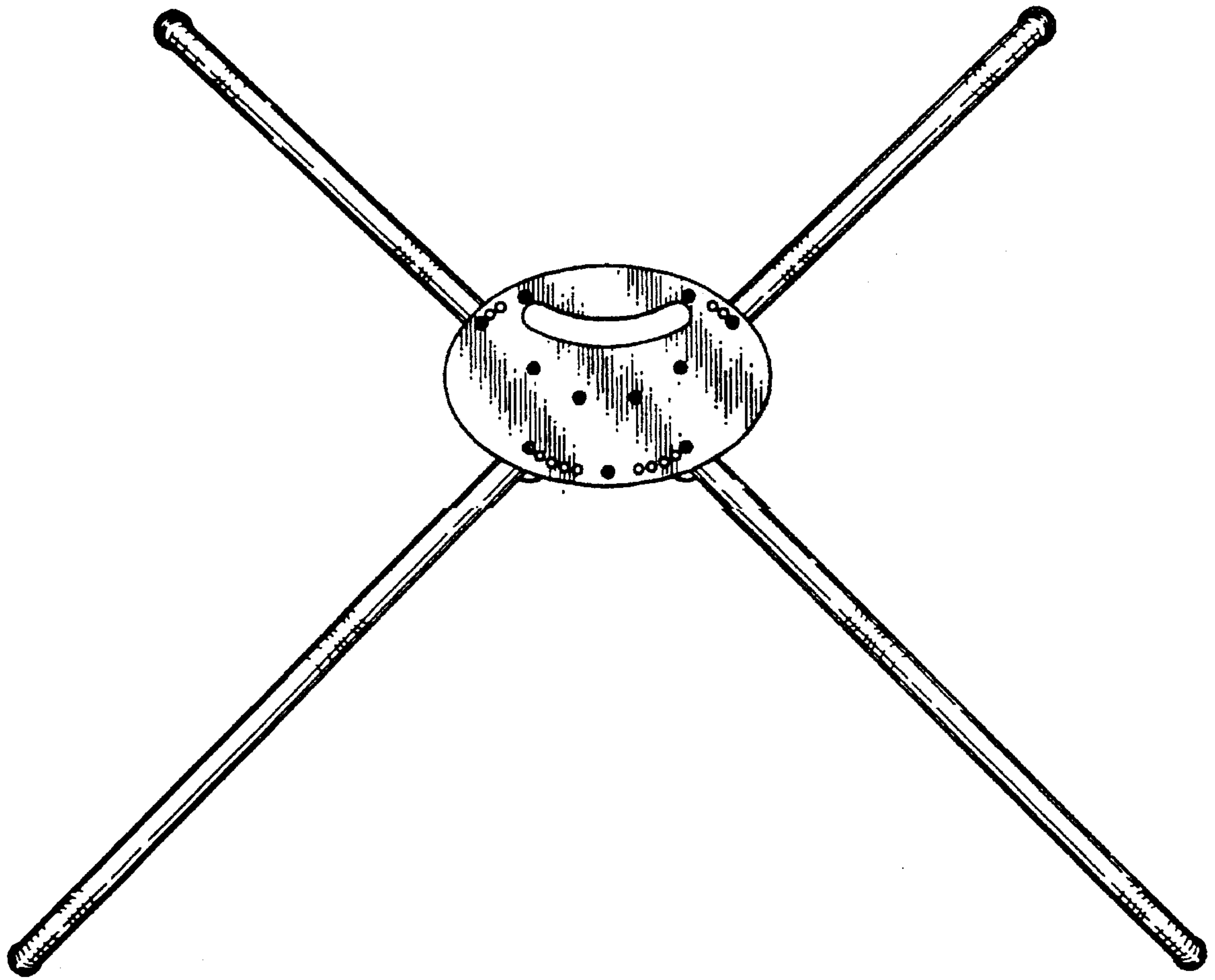

Fig. 1

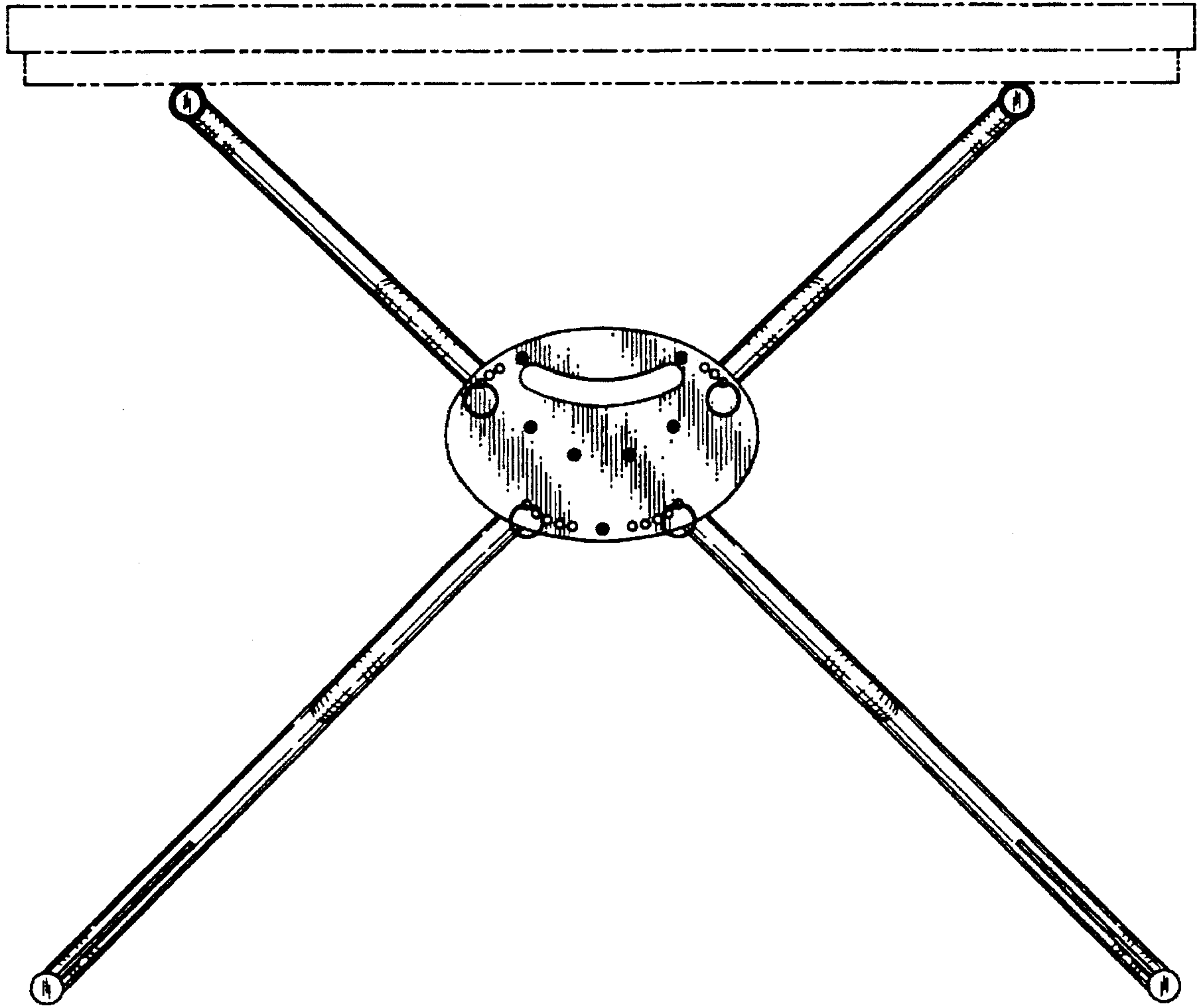

Fig. 2

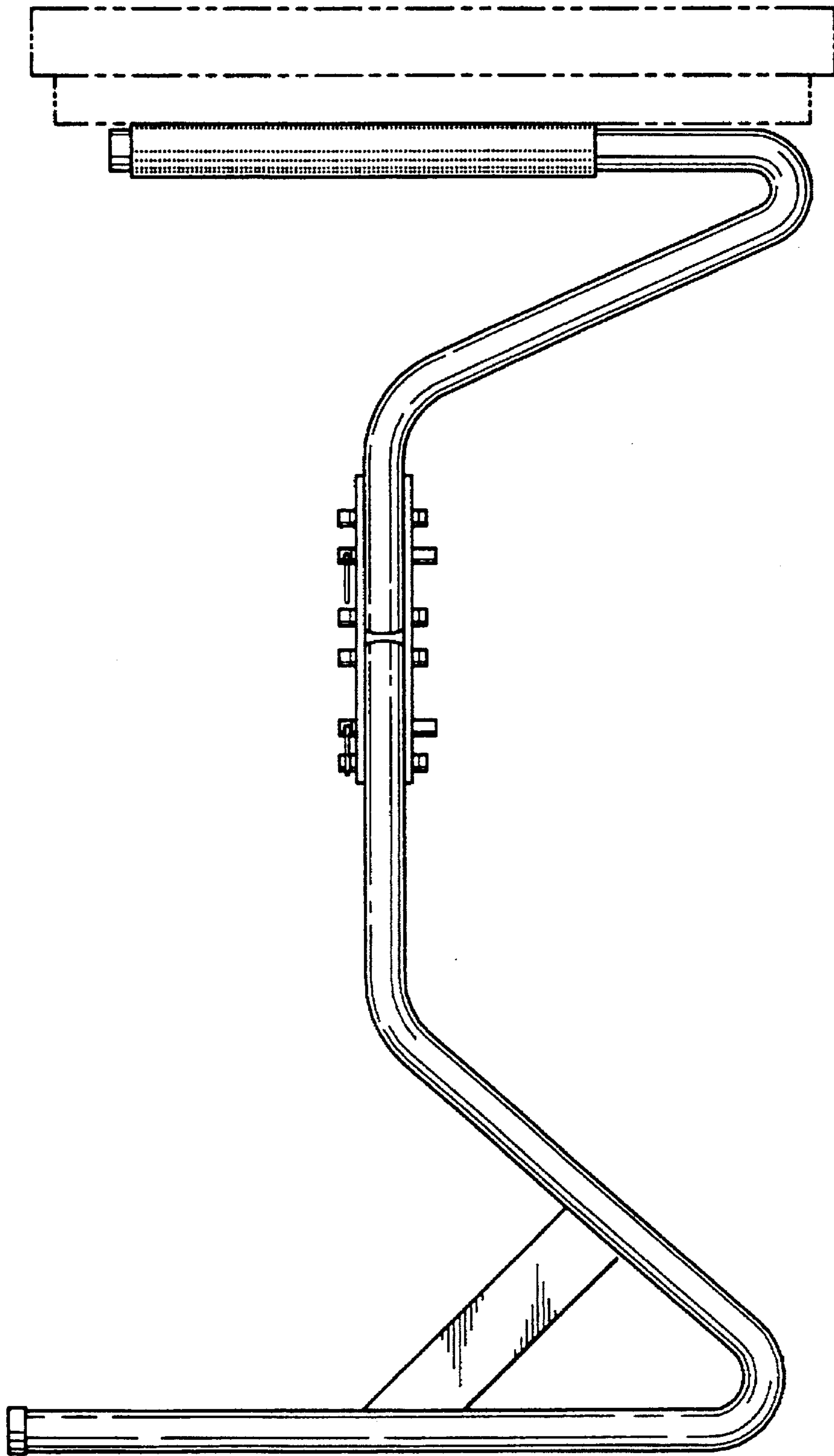

Fig. 3

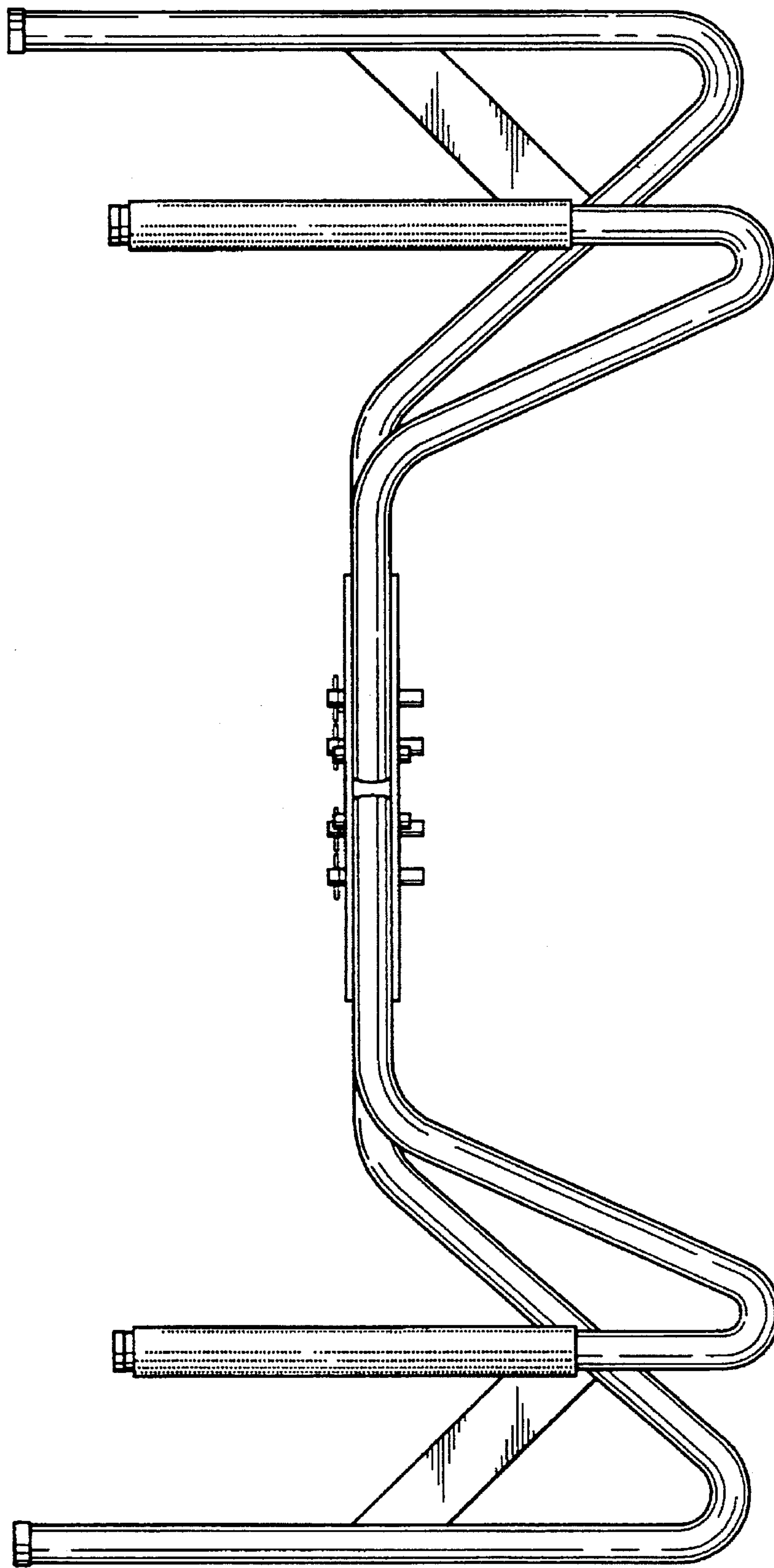

Fig. 4

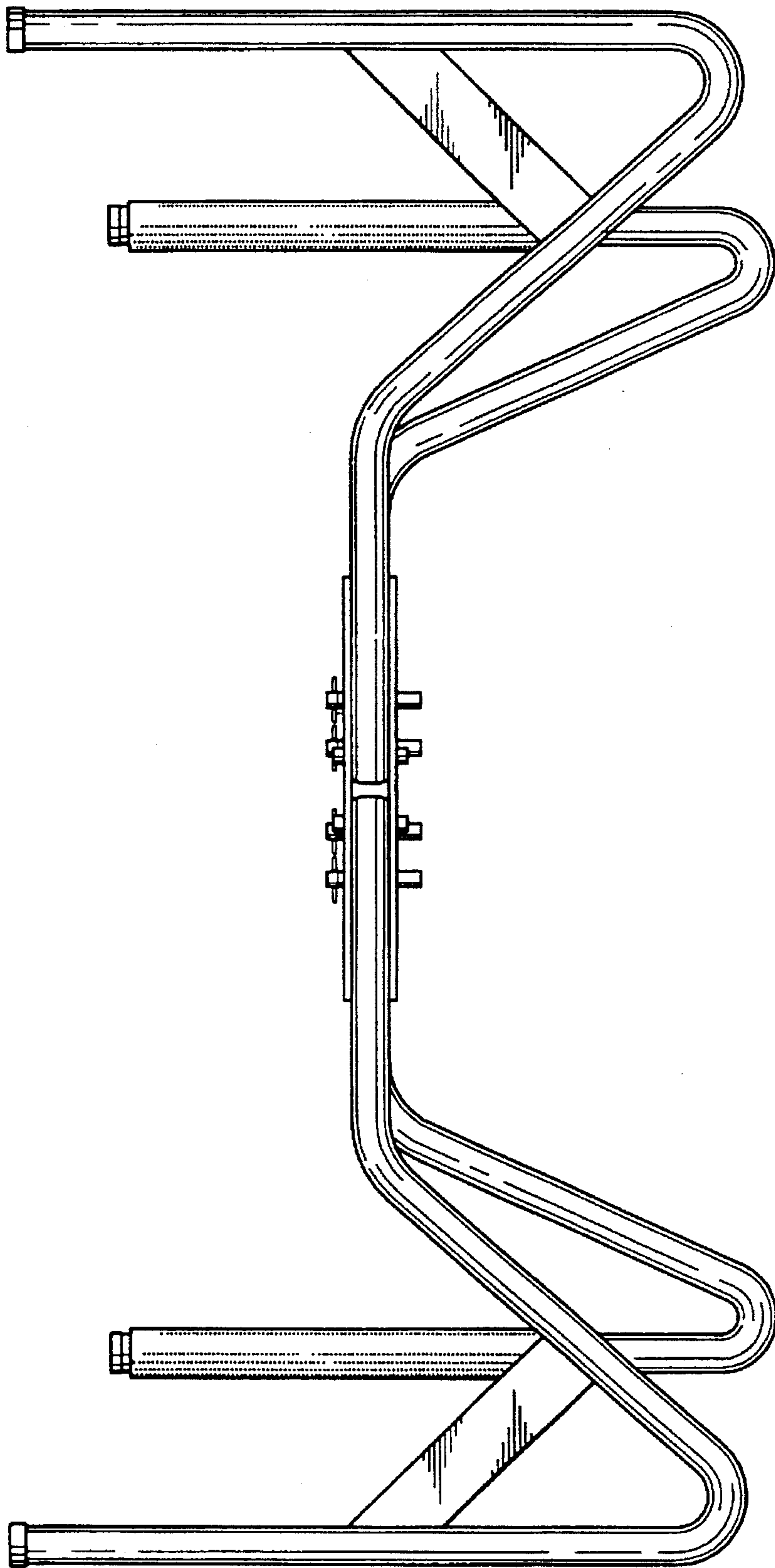

Fig. 5

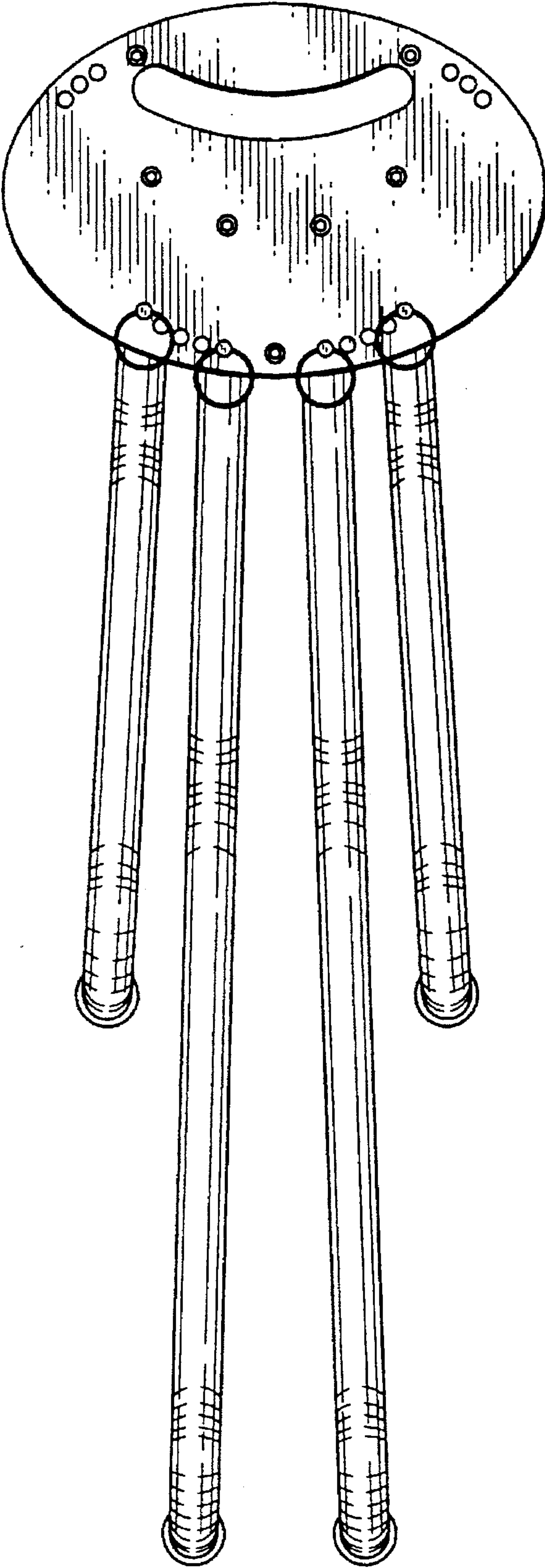

Fig. 6

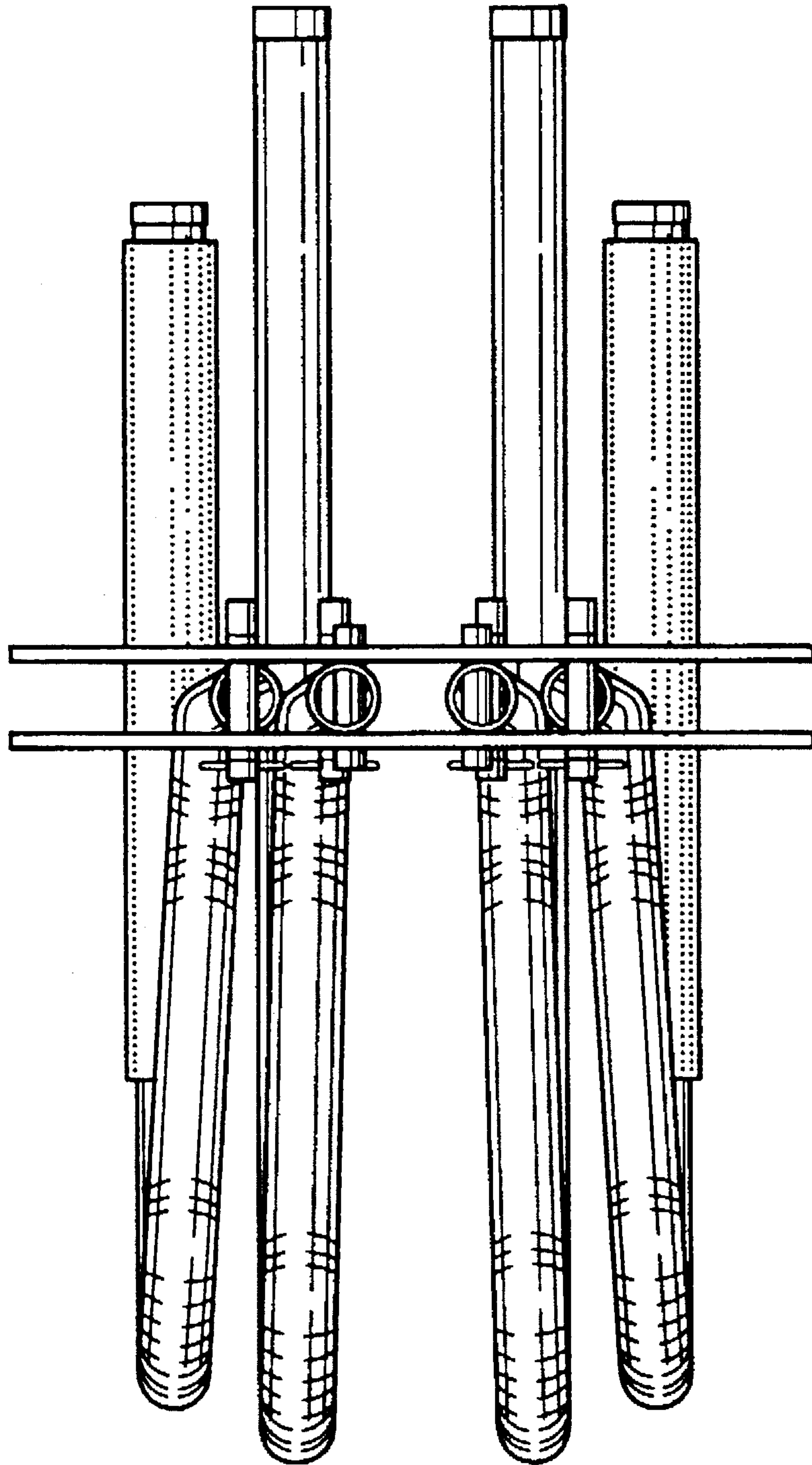

Fig. 7