



US00D382463S

United States Patent [19] Cloud

[11] Patent Number: Des. 382,463
[45] Date of Patent: **Aug. 19, 1997

[54] SEPARABLE WHEEL
[75] Inventor: George T. Cloud, Lithia Springs, Ga.
[73] Assignee: Lowtech Corporation, Inc.,
Lawrenceville, Ga.
[**] Term: 14 Years

Attorney, Agent, or Firm—Thomas, Kayden, Horsyemeyer & Risley

[21] Appl. No.: 50,496
[22] Filed: Feb. 21, 1996
[51] LOC (6) Cl. 08-05
[52] U.S. Cl. D8/354
[58] Field of Search D8/354, 356; 248/68.1,
248/74.1-74.3; 24/16 R, 16 PB; 52/652,
742, 677-689

[57] CLAIM
The ornamental design of a separable wheel, as shown and described.

DESCRIPTION

FIG. 1 is a top view of the separable wheel;
FIG. 2 is a left side view thereof;
FIG. 3 is a front view, with the rear view being a mirror image;
FIG. 4 is a right side view thereof;
FIG. 5 is a bottom view thereof;
FIG. 6 is a perspective view thereof;
FIG. 7 is a top view of the smaller segment of the claimed design;
FIG. 8 is a left elevational view thereof;
FIG. 9 is a front elevational view thereof, with the rear being a mirror image;
FIG. 10 is a right elevational view thereof;
FIG. 11 is a bottom view thereof;
FIG. 12 is a perspective view thereof;
FIG. 13 is a top view of the separable wheel with the small segment detached;
FIG. 14 is a left side view thereof;
FIG. 15 is a front view thereof with the rear view being a mirror image;
FIG. 16 is a right side view thereof;
FIG. 17 is a bottom view thereof; and,
FIG. 18 is a perspective view thereof.
The smaller segment of the claimed design is shown detached for clarity of illustration.

[56] References Cited

U.S. PATENT DOCUMENTS

D. 223,701	5/1972	Lausch	8/228
D. 362,382	9/1995	Cloud	8/354
3,191,345	6/1965	Schwachula	50/510
3,280,529	10/1966	Reuss	52/689
5,027,478	7/1991	Suhr	24/16
5,347,787	9/1994	Gavin	52/677

FOREIGN PATENT DOCUMENTS

14 84 980	4/1967	Germany .
21 40 424	3/1973	Germany .
24 27 829	1/1976	Germany .
434659	10/1967	Switzerland .
623942	5/1949	United Kingdom .

OTHER PUBLICATIONS

PlasChair brochure, Aug. 24, 1984, cover page, rebar spacer located in center of page.

Primary Examiner—Holly Baynham

1 Claim, 5 Drawing Sheets

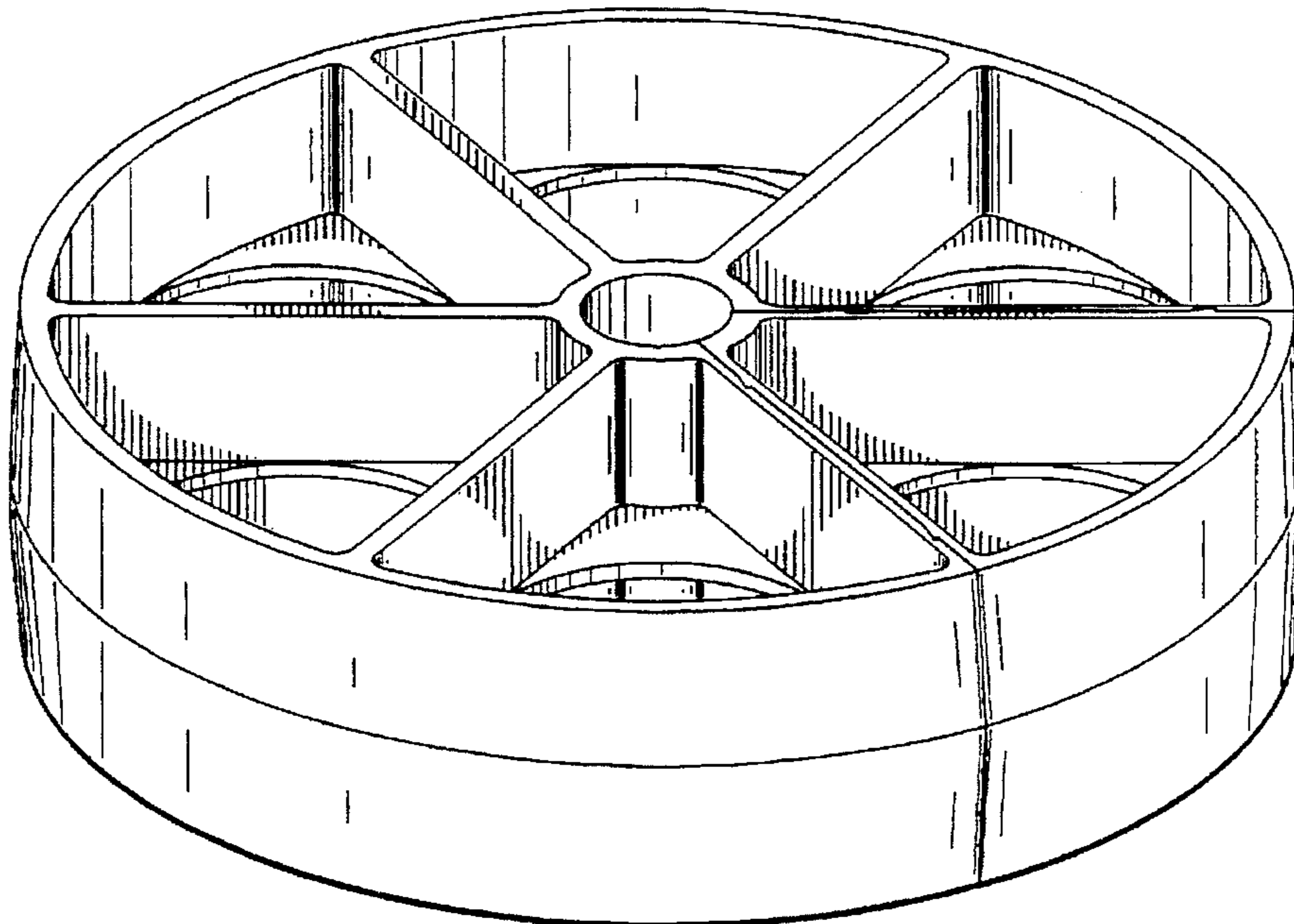

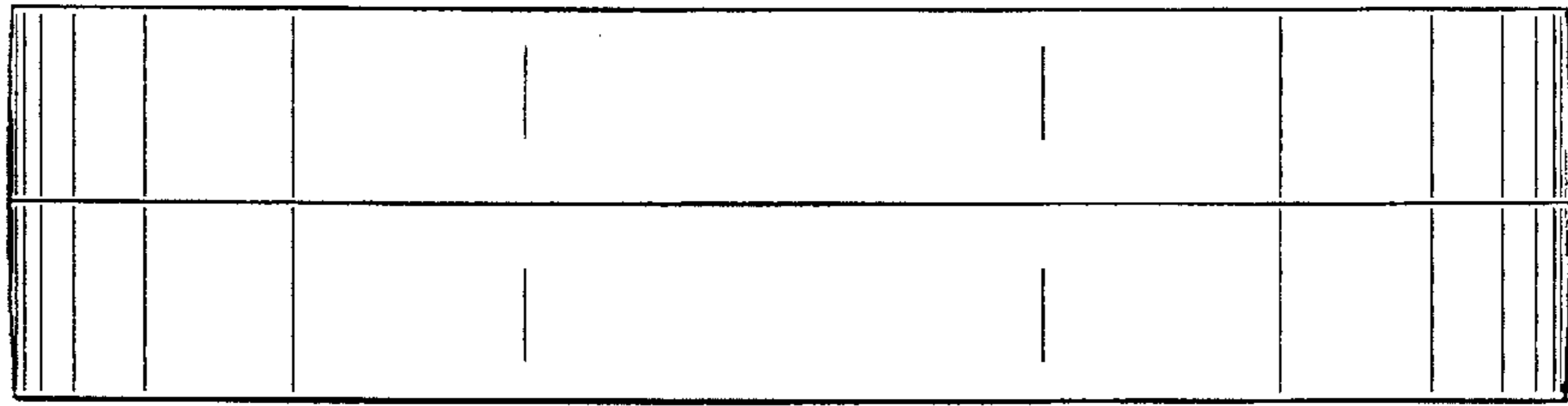

FIG. 1

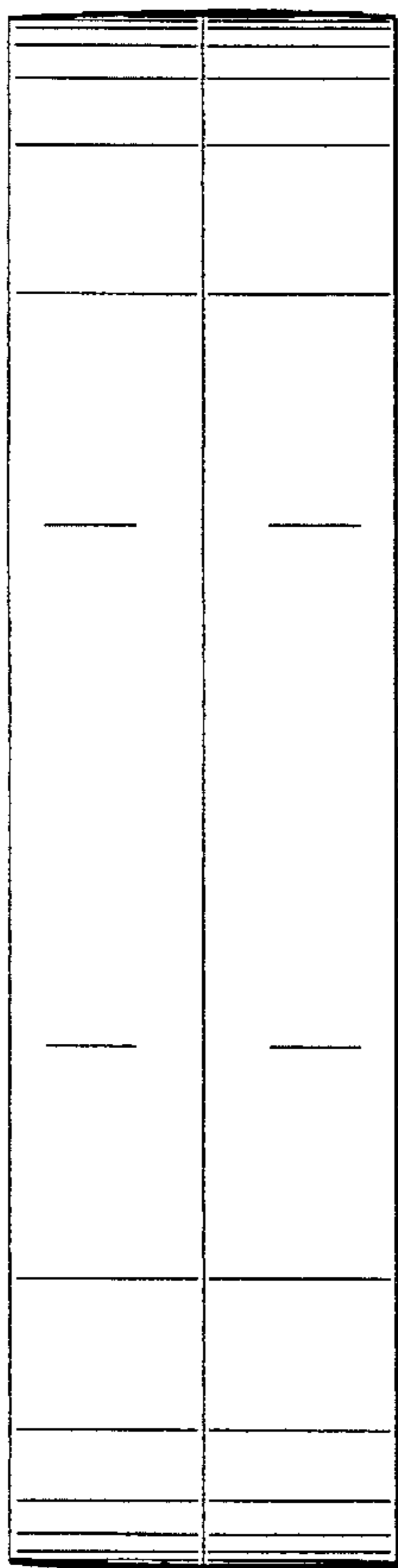

FIG. 2

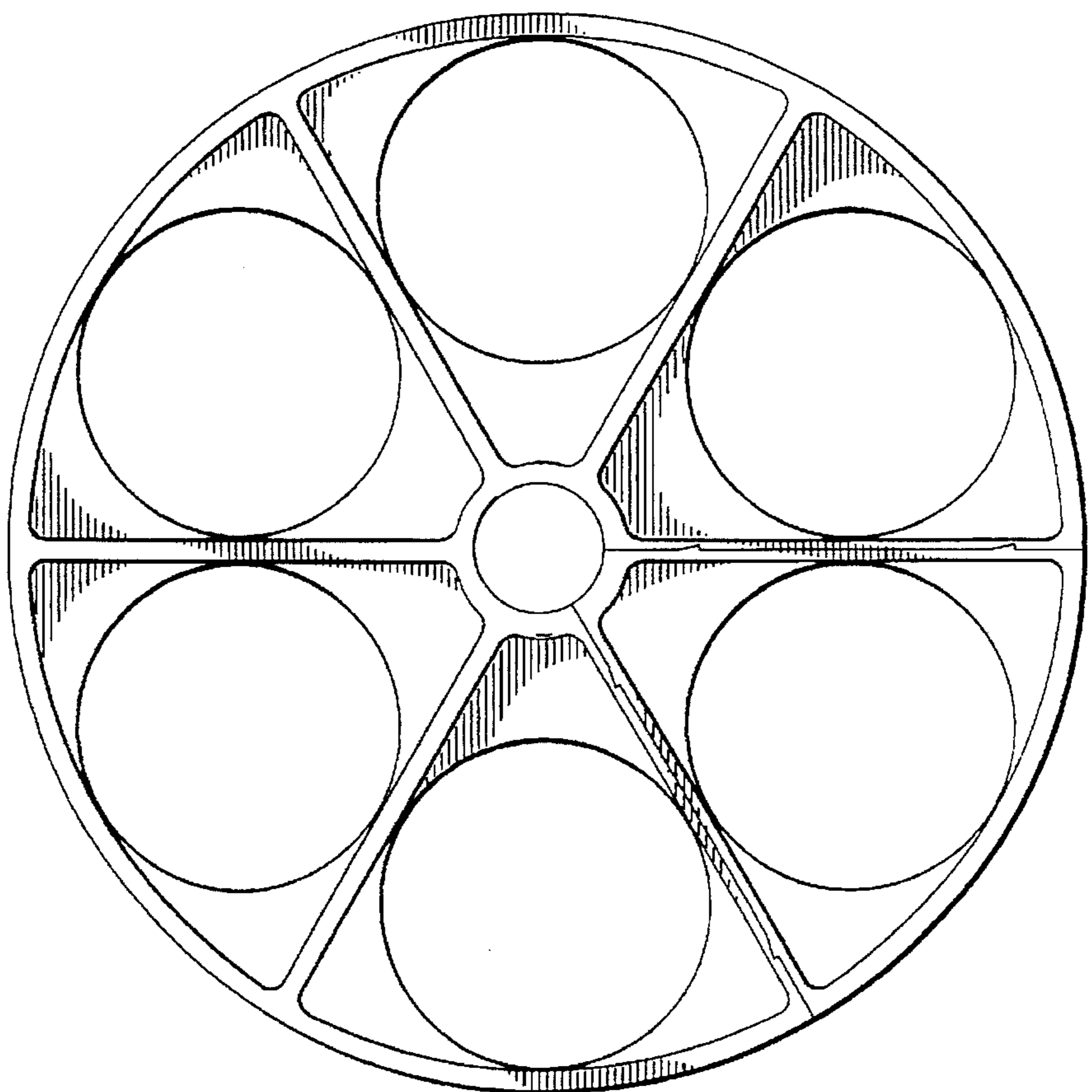

FIG. 3

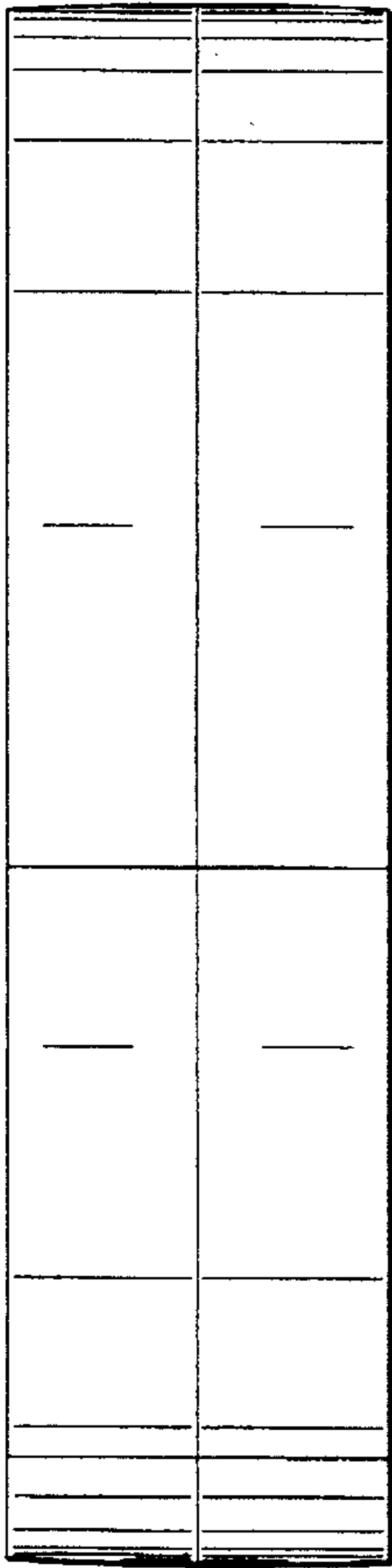

FIG. 4

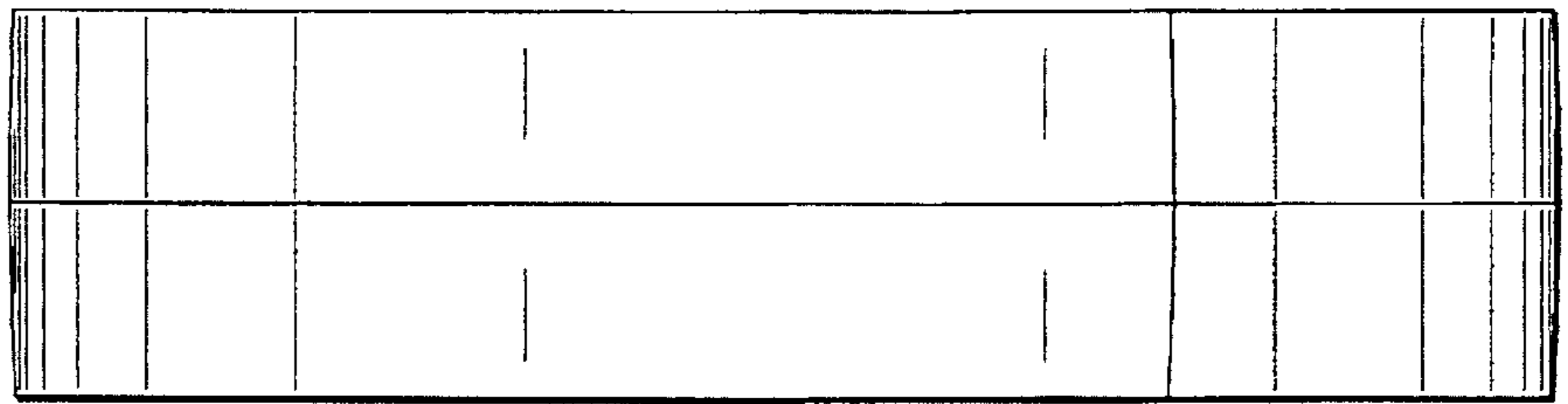

FIG. 5

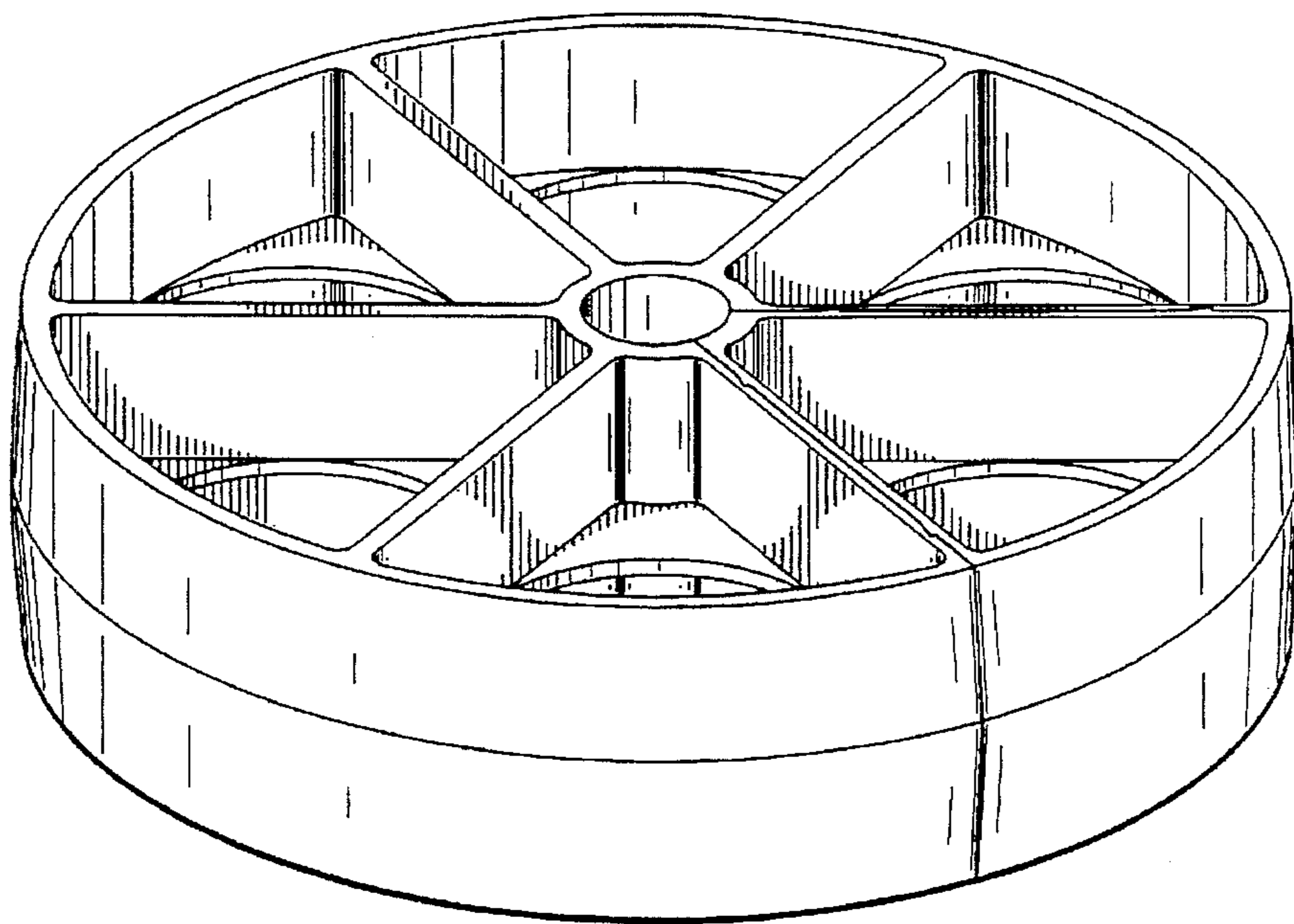

FIG. 6

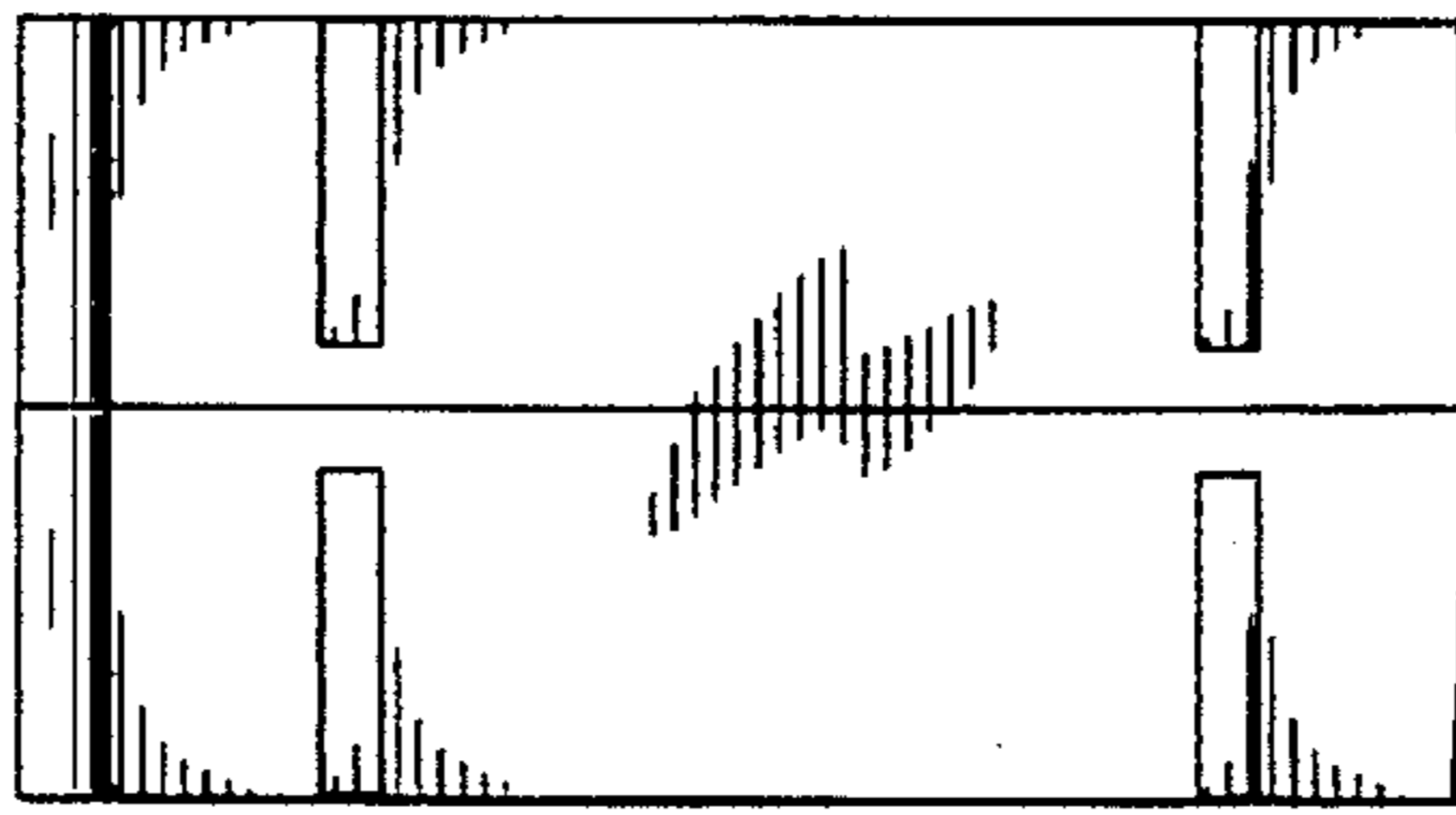

FIG. 7

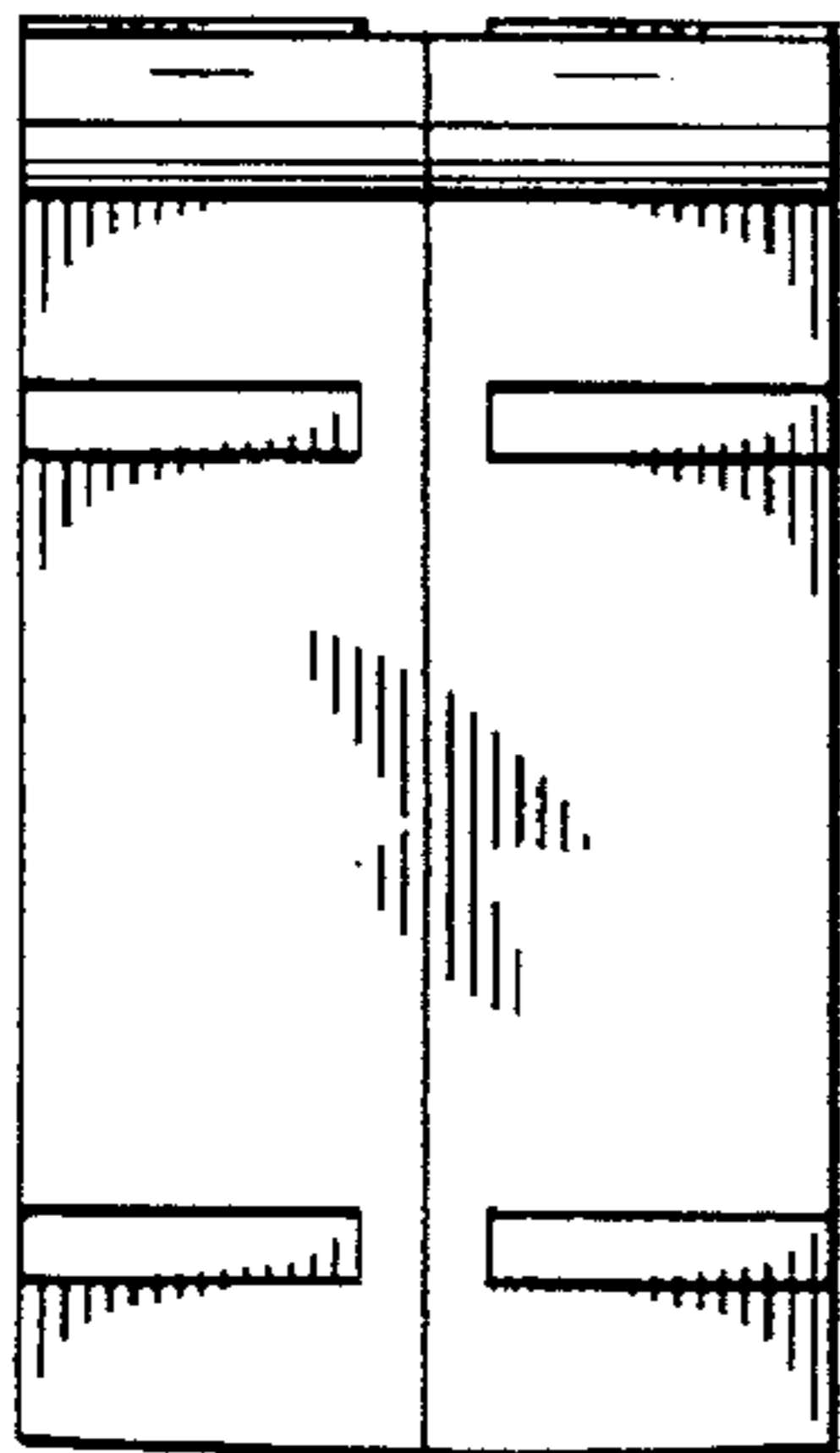

FIG. 8

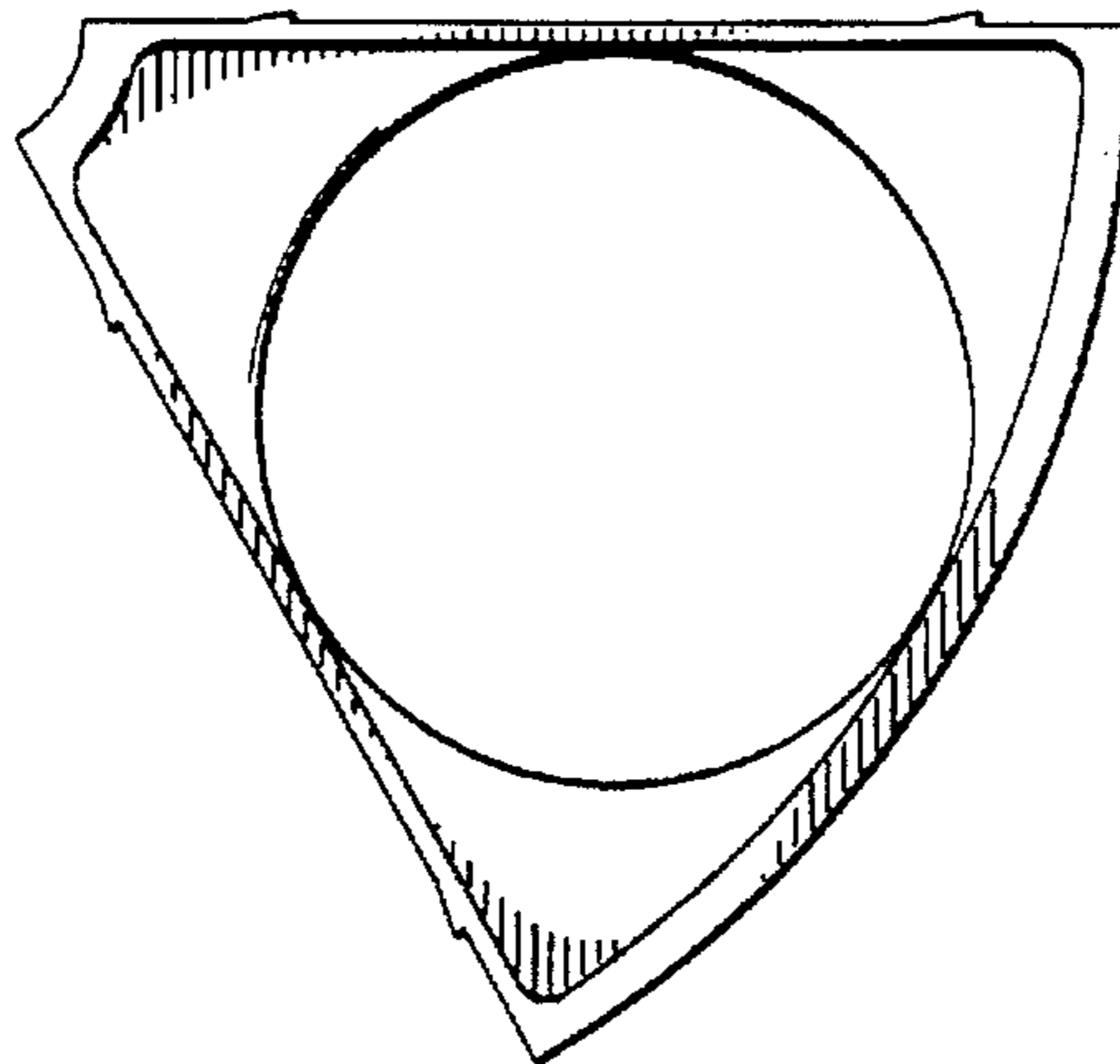

FIG. 9

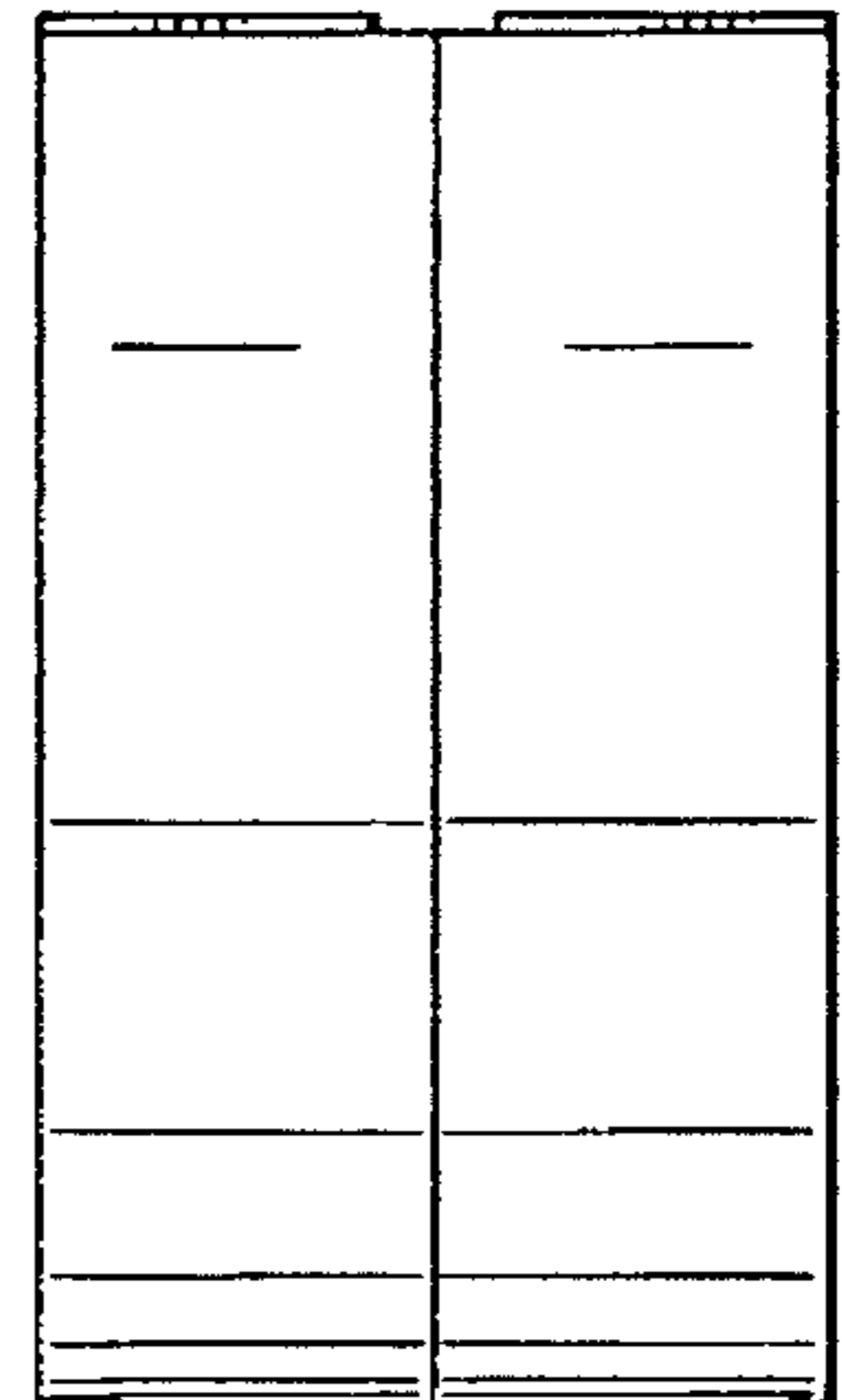

FIG. 10

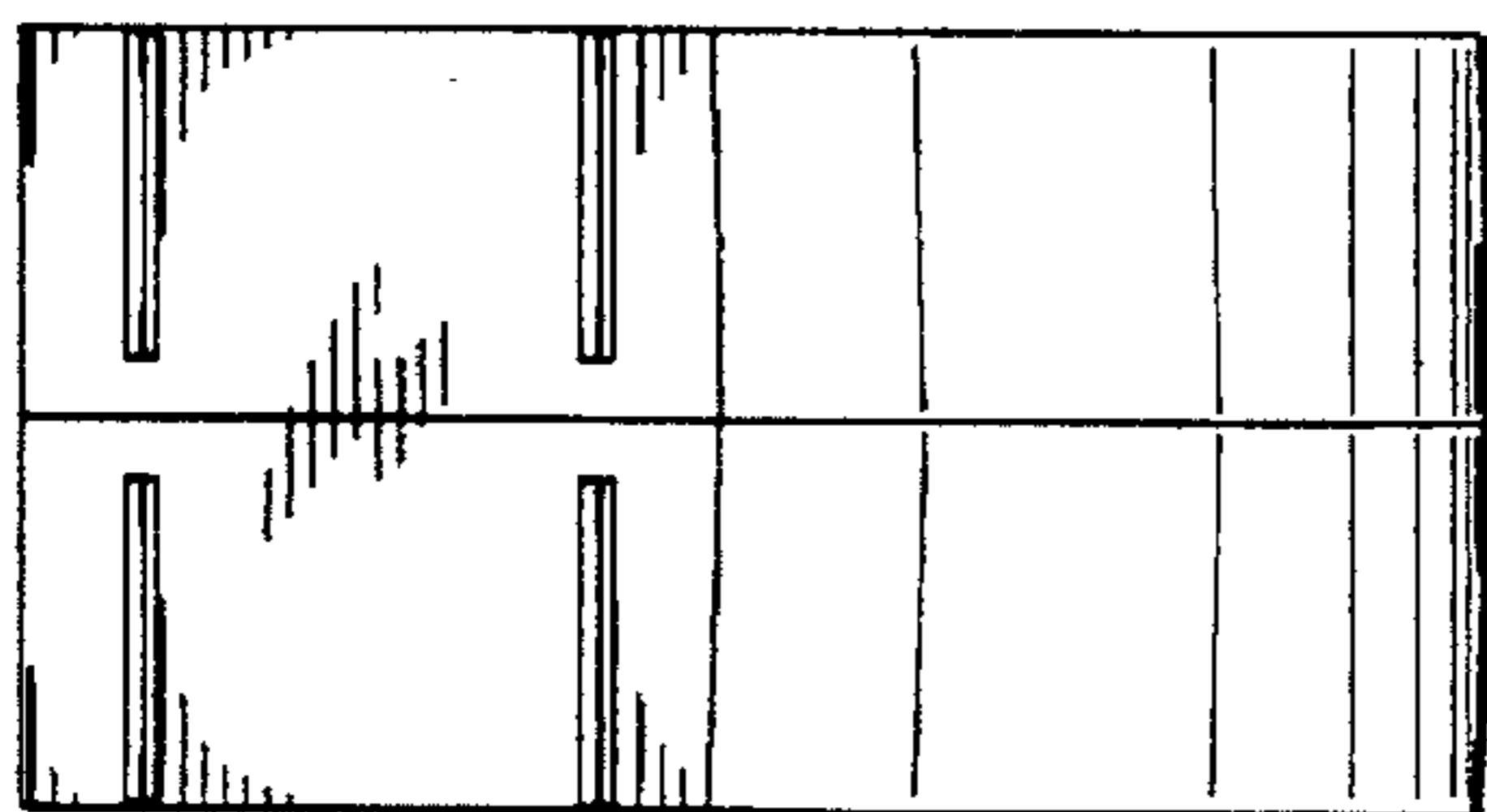

FIG. 11

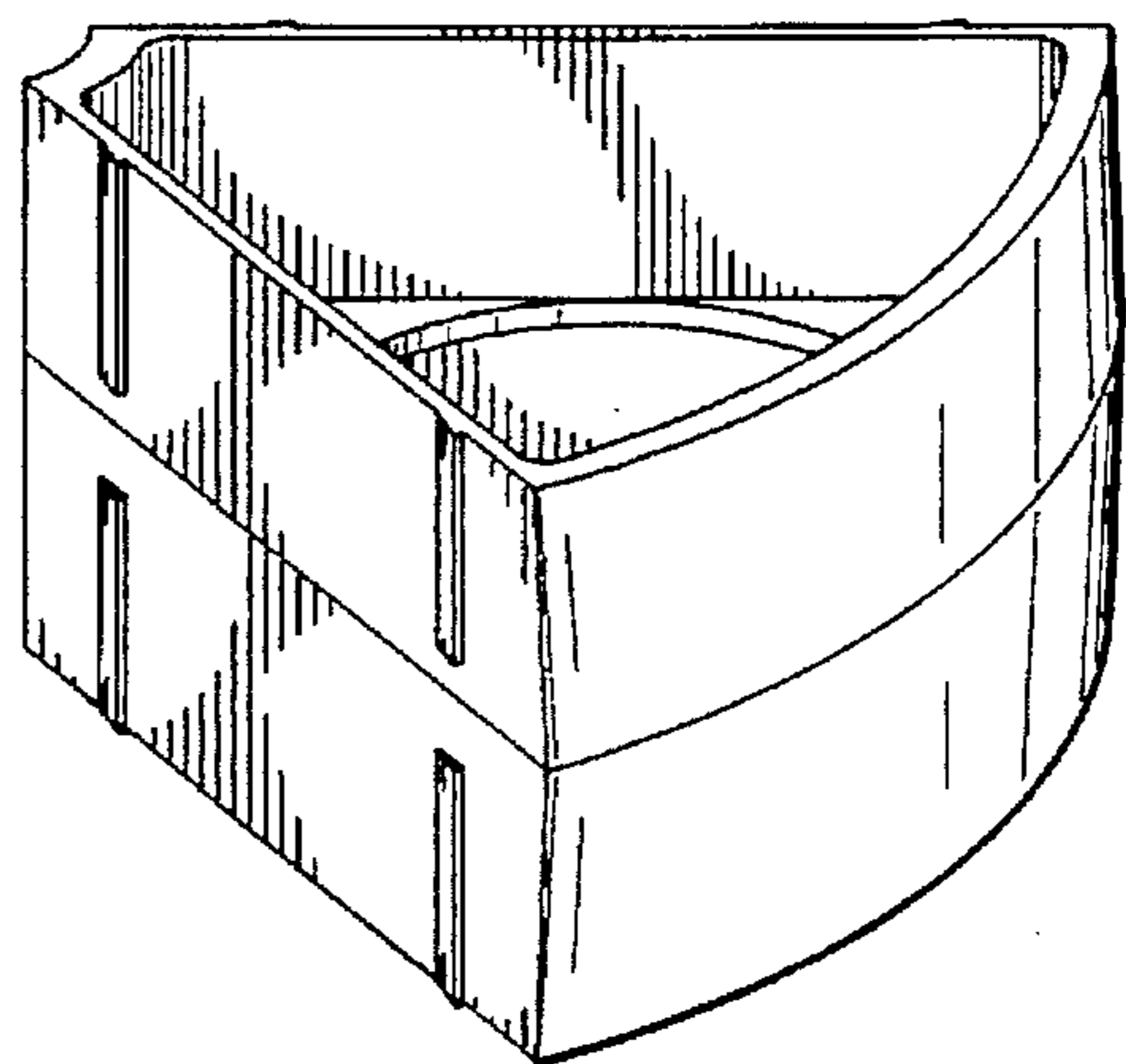

FIG. 12

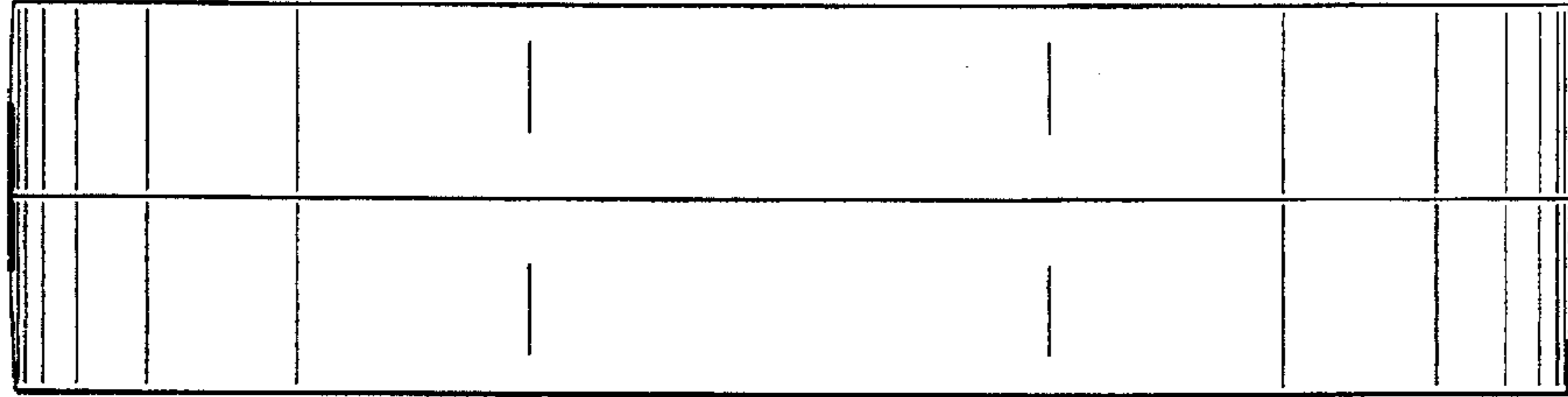

FIG. 13

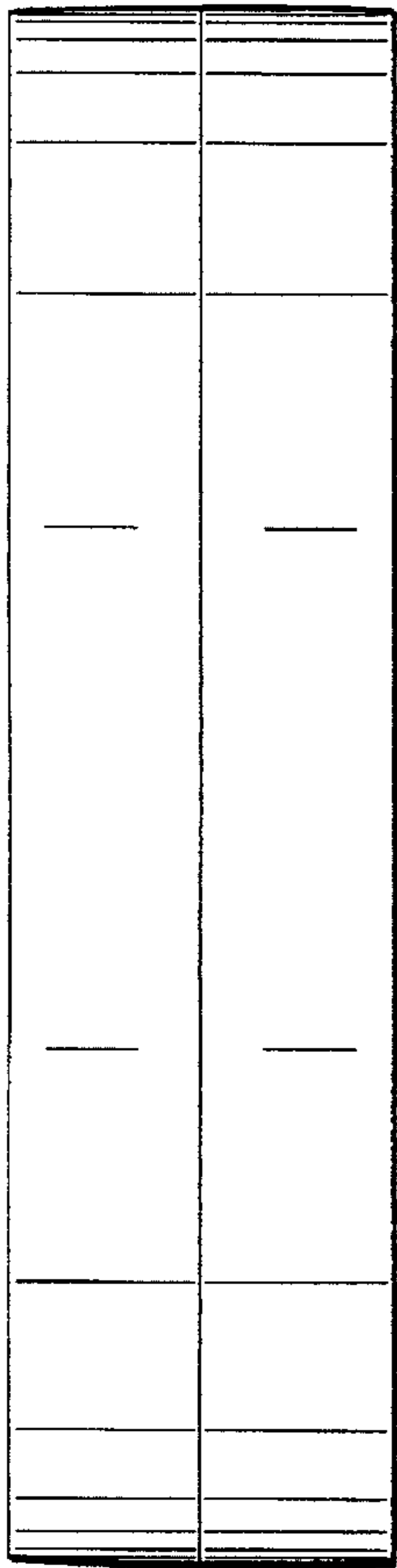

FIG. 14

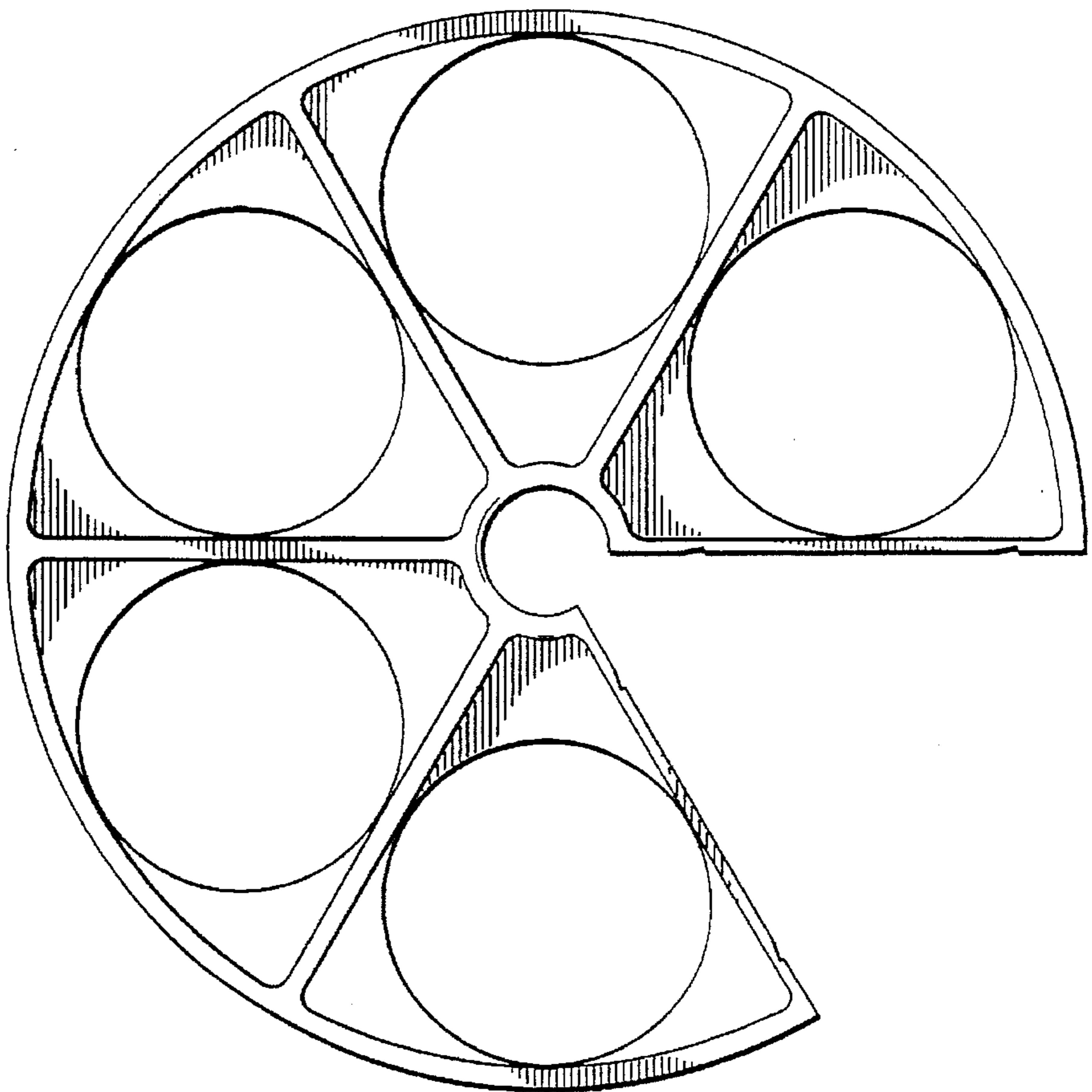

FIG. 15

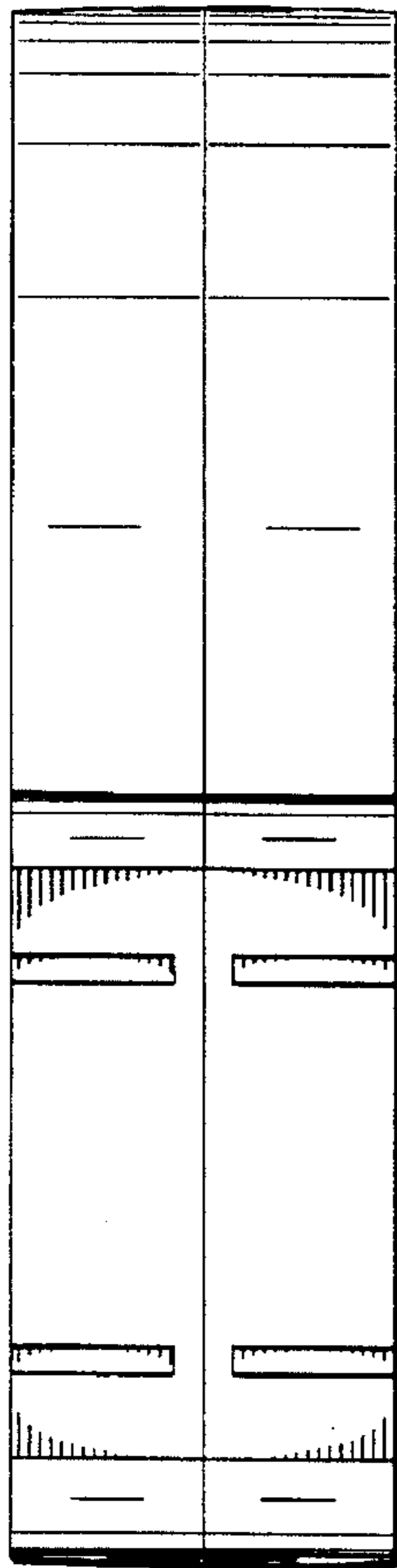

FIG. 16

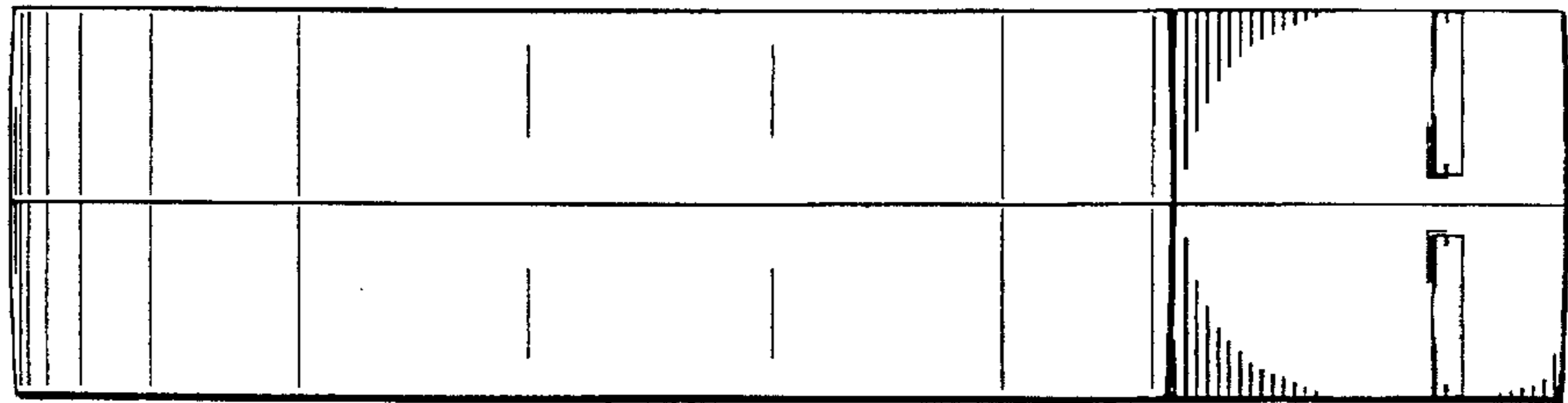

FIG. 17

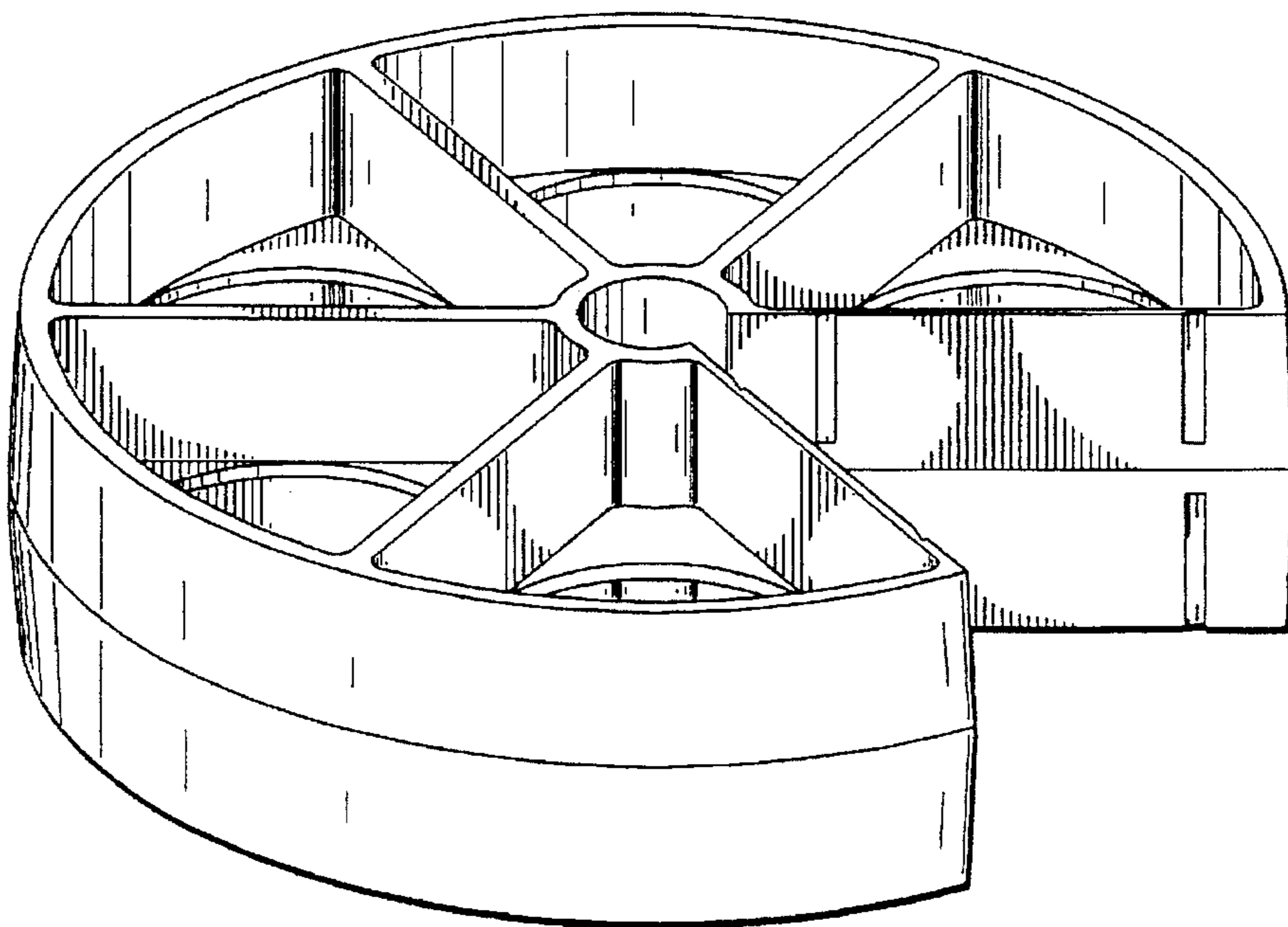

FIG. 18