



US00D382339S

United States Patent [19] Coble

[11] Patent Number: Des. 382,339
[45] Date of Patent: **Aug. 12, 1997

[54] **ARCuate CAST REFRACTORY AND STEEL SEGMENT OF AN ANNEALING FURNACE BASE**

[76] Inventor: **Gary L. Coble, R.D. #2, Box 214, DuBois, Pa. 15801**

[**] Term: **14 Years**

[21] Appl. No.: **32,590**

[22] Filed: **Dec. 21, 1994**

[51] **LOC (6) Cl. 23-03**

[52] **U.S. Cl. D23/386; D23/329**

[58] **Field of Search D23/386, 329; 432/254.2, 258; 266/280, 286, 282; D25/113, 199, 116, 154**

[56] References Cited

U.S. PATENT DOCUMENTS

D. 344,350	2/1994	De Pascale et al.	D25/113
1,829,320	10/1931	White .	
2,998,236	8/1961	Cramer et al.	263/40
3,039,754	6/1962	Jones	263/47
3,081,074	3/1963	Blackman et al.	263/47
3,149,827	9/1964	Whitten	263/47
3,693,955	9/1972	Wald et al.	266/5
4,011,683	3/1977	De Sousa	46/25
4,294,438	10/1981	Nystrom et al.	266/280
4,516,758	5/1985	Coble	266/263
4,611,791	9/1986	Coble	266/263
4,647,022	3/1987	Coble	266/282
4,653,171	3/1987	Coble	29/455
4,755,236	7/1988	Coble	148/13
5,048,802	9/1991	Coble	266/263
5,308,046	5/1994	Coble	266/263
5,335,897	8/1994	Coble	266/286

FOREIGN PATENT DOCUMENTS

1131246	12/1956	Germany	266/262
---------	---------	---------------	---------

Primary Examiner—Lisa Lichtenstein
Attorney, Agent, or Firm—David A. Burge

[57] CLAIM

The ornamental design for an arcuate cast refractory and steel segment of an annealing furnace base, as shown and described.

DESCRIPTION

FIG. 1 is a perspective view of one form of an arcuate cast refractory and steel segment of an annealing furnace base embodying my design, with the view showing principally top and front portions thereof;

FIG. 2 is a perspective view thereof showing principally bottom and rear portions thereof;

FIGS. 3 and 4 are top and bottom plan views thereof, respectively;

FIGS. 5 and 6 are front and rear elevational views thereof, respectively;

FIGS. 7 and 8 are left and right elevational views thereof, respectively;

FIG. 9 is a perspective view of a second form of an arcuate cast refractory and steel segment of an annealing furnace base embodying my design, with the view showing principally top and front portions thereof;

FIG. 10 is a perspective view of FIG. 9 showing principally bottom and rear portions thereof;

FIGS. 11 and 12 are top and bottom plan views of FIG. 9, respectively;

FIGS. 13 and 14 are front and rear elevational views of FIG. 9, respectively, but taken with the segment oriented as it is depicted in FIGS. 11 and 12;

FIGS. 15 and 16 are left and right elevational views of FIG. 9, respectively, but taken with the segment oriented as it is depicted in FIGS. 11 and 12;

FIG. 17 is a perspective view of a third form of an arcuate cast refractory and steel segment of an annealing furnace base embodying my design, with the view showing principally top and front portions thereof;

FIG. 18 is a perspective view of FIG. 17 showing principally bottom and rear portions thereof;

FIGS. 19 and 20 are top and bottom plan views of FIG. 17, respectively;

FIGS. 21 and 22 are front and rear elevational views, of FIG. 17, respectively;

FIGS. 23 and 24 are left and right elevational views of FIG. 17, respectively;

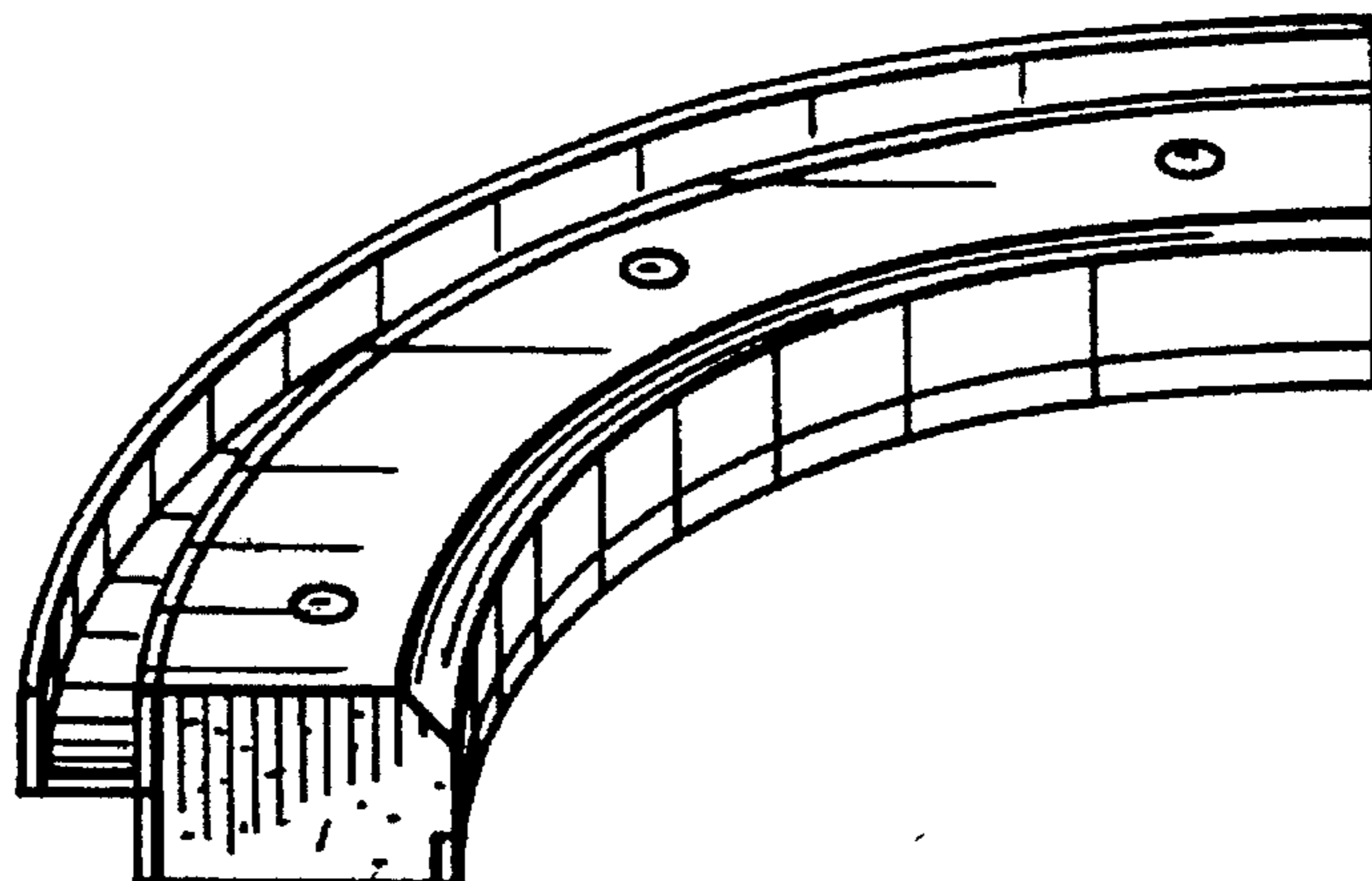

FIG. 25 is a perspective view of a fourth form of an arcuate cast refractory and steel segment of an annealing furnace base embodying my design, with the view showing principally top and front portions thereof;

FIG. 26 is a perspective view of FIG. 25 showing principally bottom and rear portions thereof;

FIGS. 27 and 28 are top and bottom plan views of FIG. 25, respectively;

FIGS. 29 and 30 are front and rear elevational views of FIG. 25, respectively, but taken with the segment oriented as it is depicted in FIGS. 27 and 28;

FIGS. 31 and 32 are left and right elevational views of FIG. 25, respectively, but taken with the segment oriented as it is depicted in FIGS. 27 and 28;

FIG. 33 is a perspective view of a fifth form of an arcuate cast refractory and steel segment of an annealing furnace base embodying my design, with the view showing principally top and front portions thereof;

FIG. 34 is a perspective view of FIG. 33 showing principally bottom and rear portions thereof;

FIGS. 35 and 36 are top and bottom plan views of FIG. 33, respectively;

FIGS. 37 and 38 are front and rear elevational views of FIG. 33, respectively;

FIGS. 39 and 40 are left and right elevational views of FIG. 33, respectively;

FIG. 41 is a perspective view of a sixth form of an arcuate cast refractory and steel segment of an annealing furnace base embodying my design, with the view showing principally top and front portions thereof;

FIG. 42 is a perspective view of FIG. 41 showing principally bottom and rear portions thereof;

FIGS. 43 and 44 are top and bottom plan views of FIG. 41, respectively;

FIGS. 45 and 46 are front and rear elevational views of FIG. 41, respectively, but taken with the segment oriented as it is depicted in FIGS. 43 and 44; and,

FIGS. 47 and 48 are left and right elevational views of FIG. 41, respectively, but taken with the segment oriented as it is depicted in FIGS. 43 and 44.

1 Claim, 6 Drawing Sheets

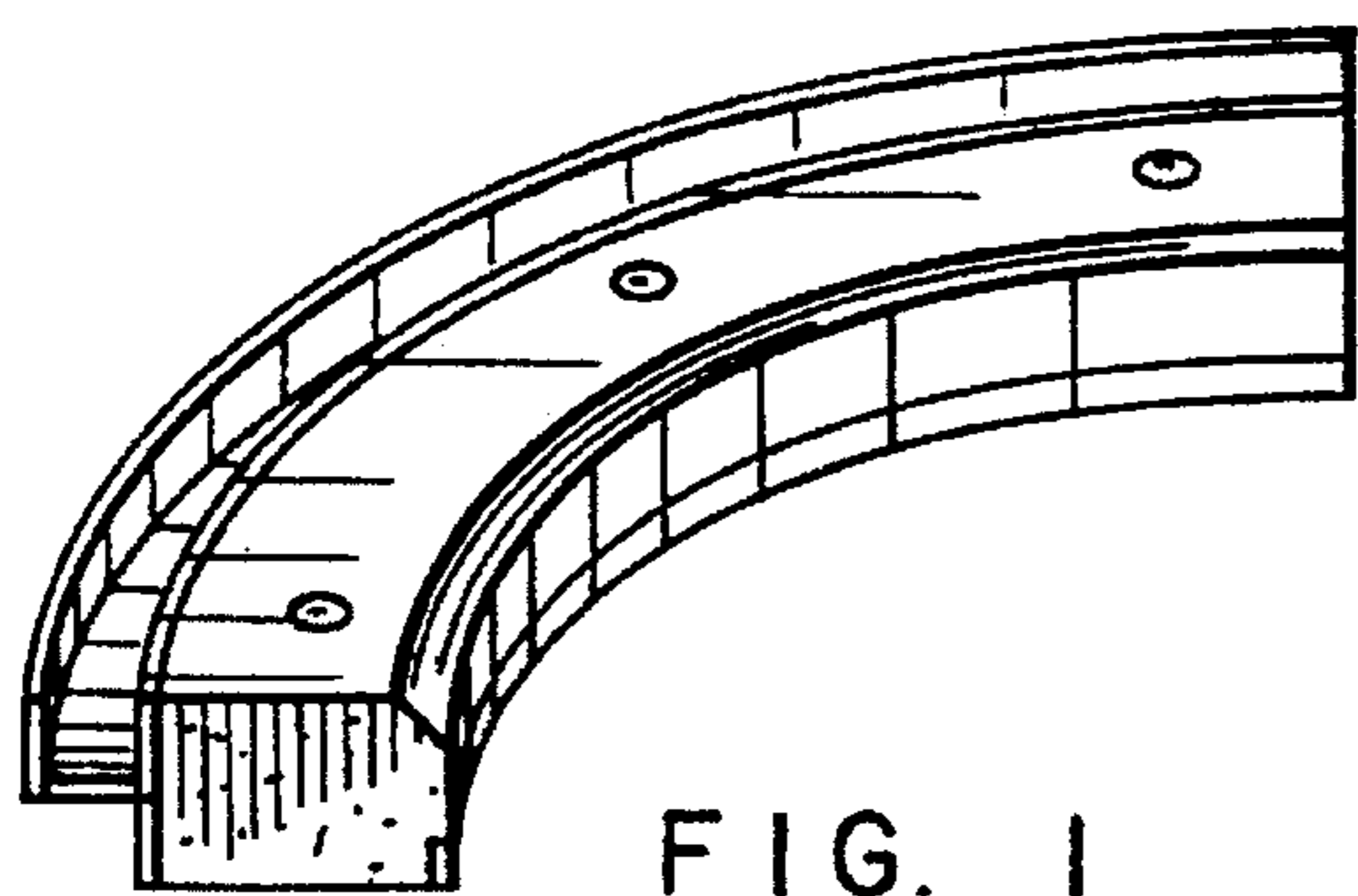

FIG. 1

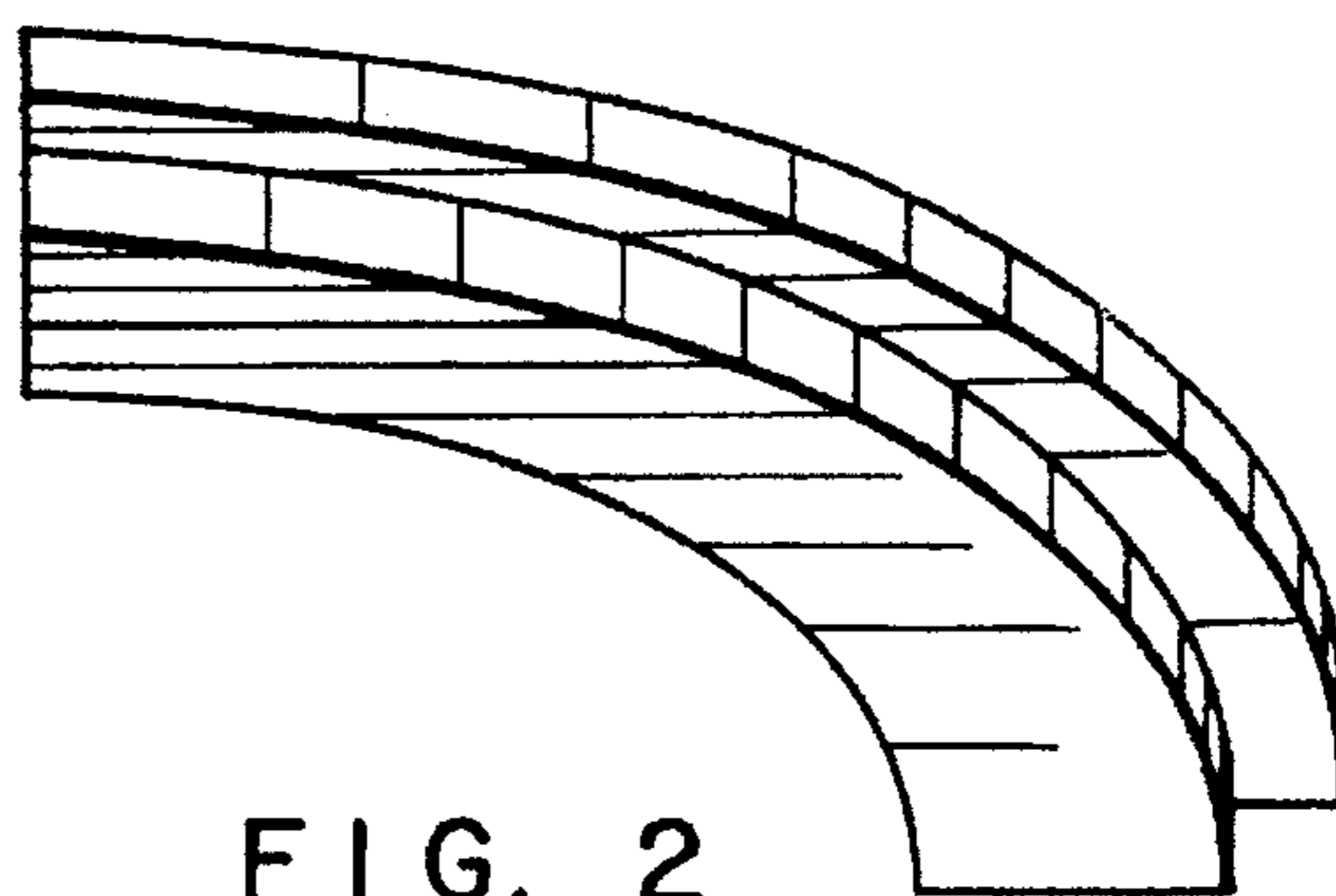

FIG. 2



FIG. 6

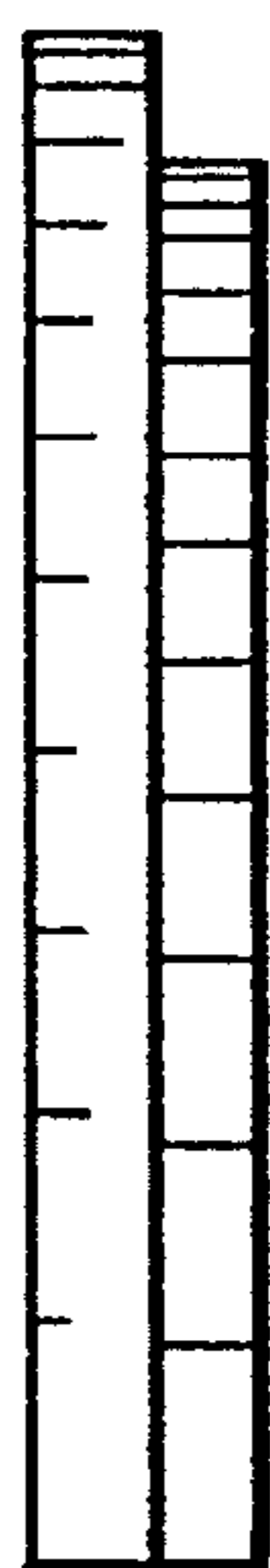

FIG. 7

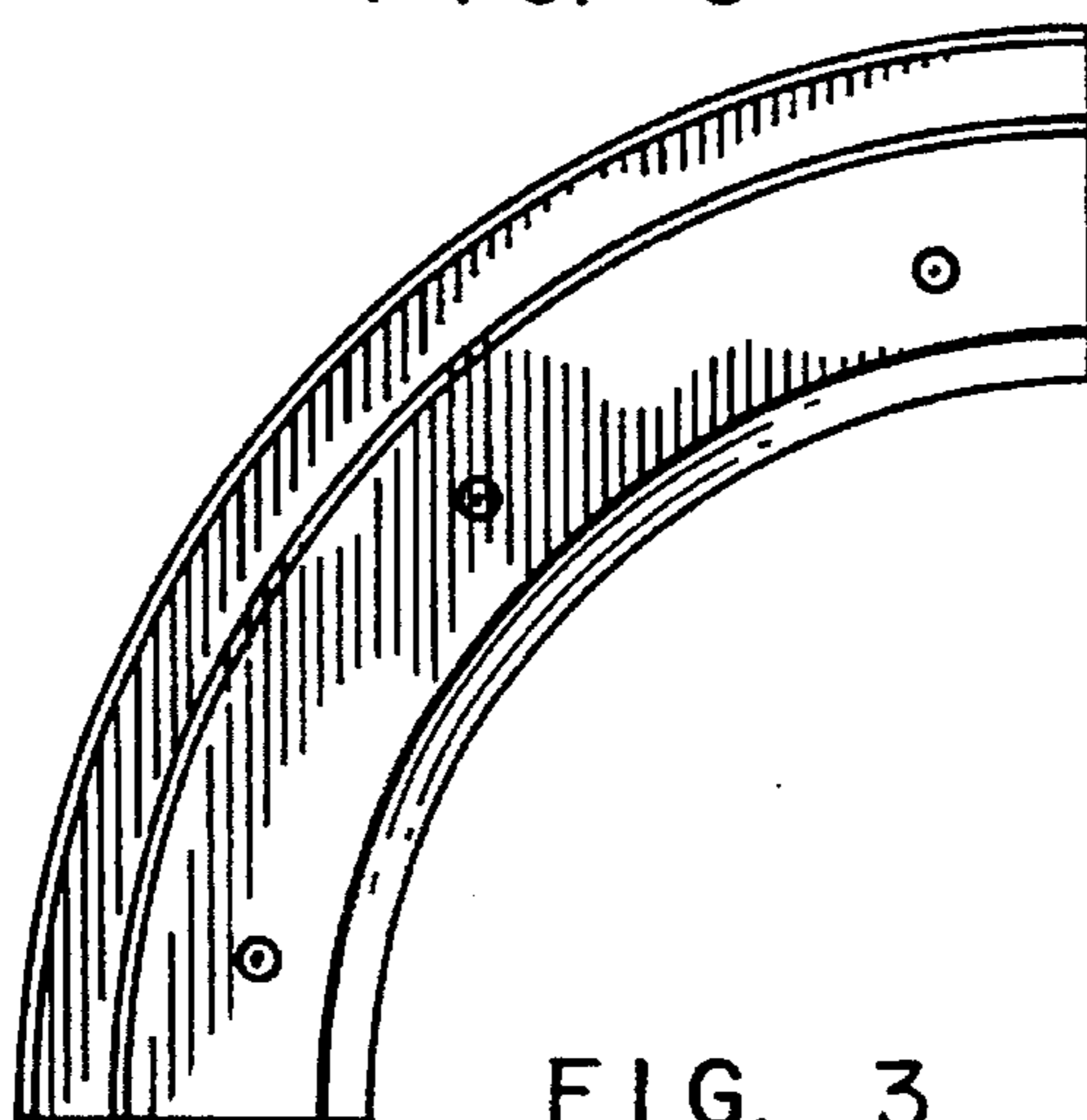

FIG. 3

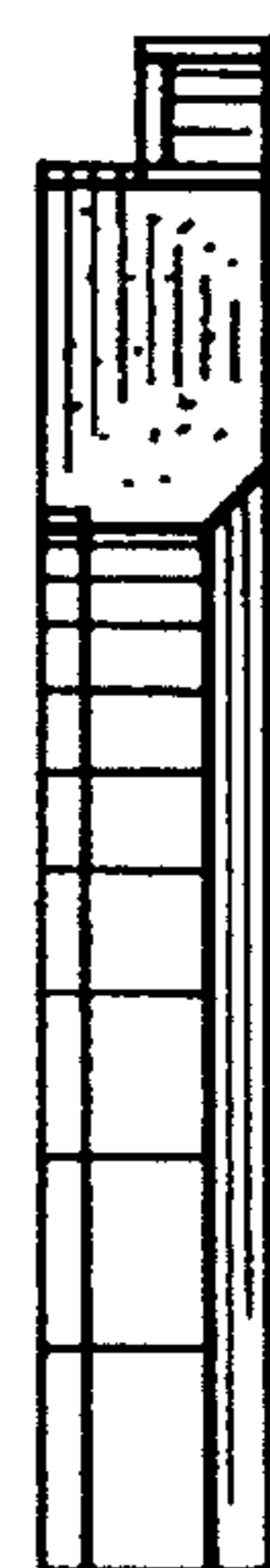

FIG. 8

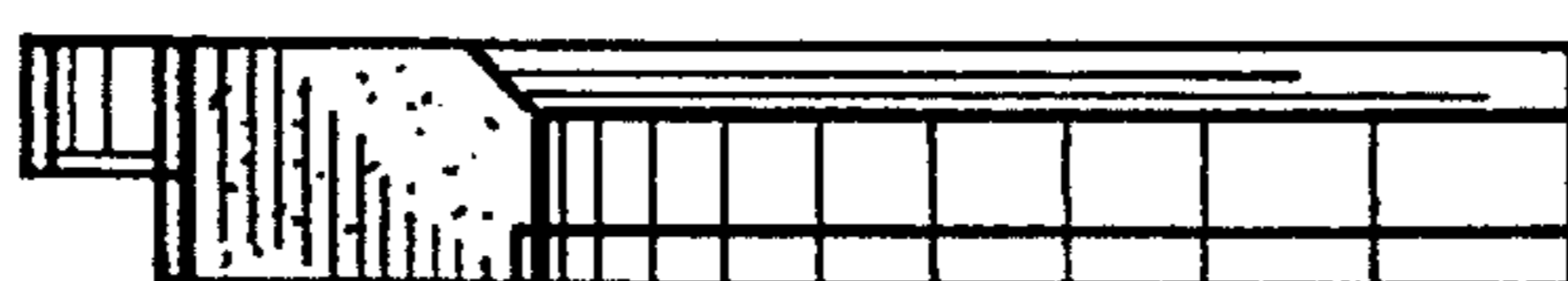

FIG. 5

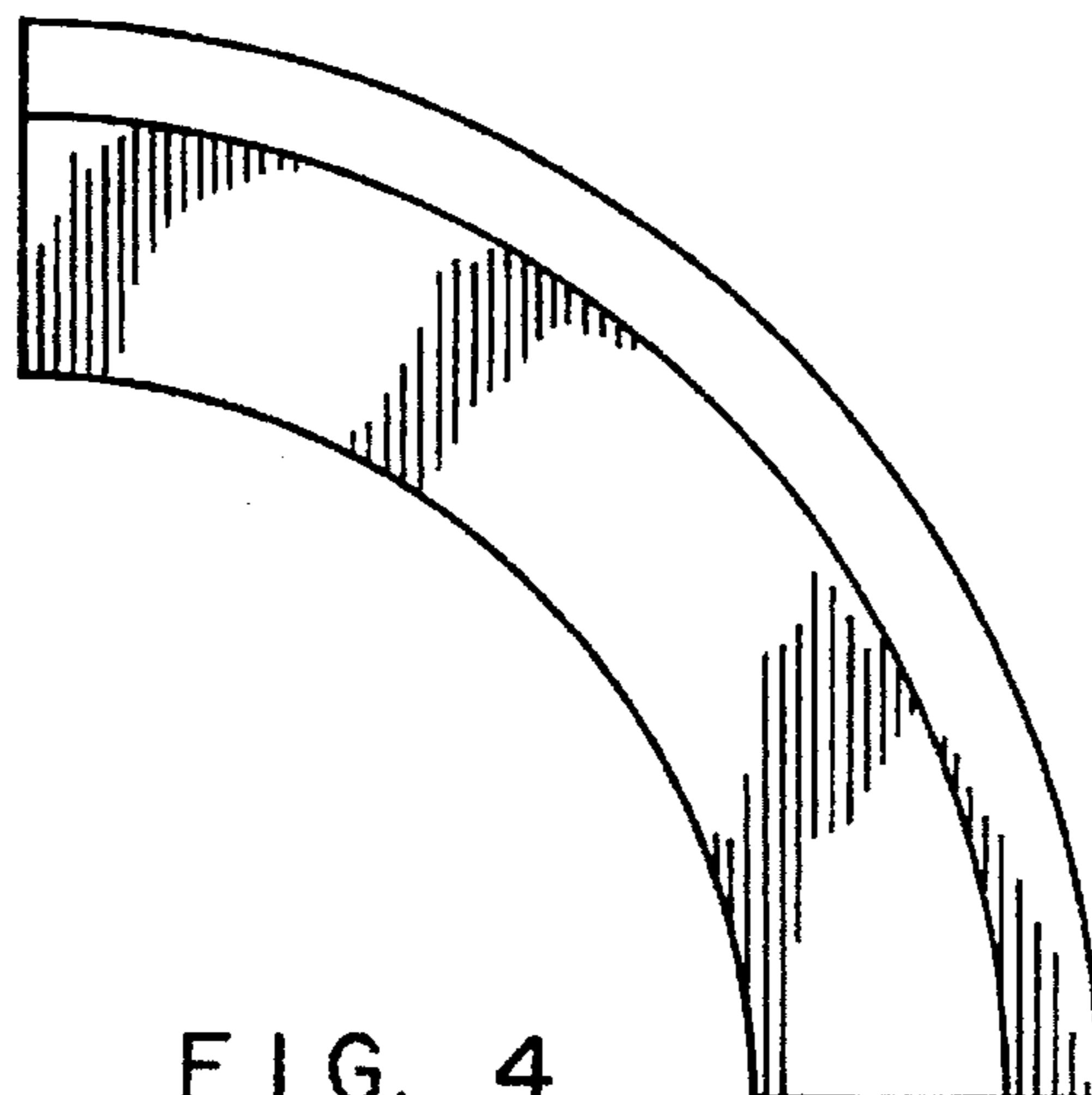

FIG. 4

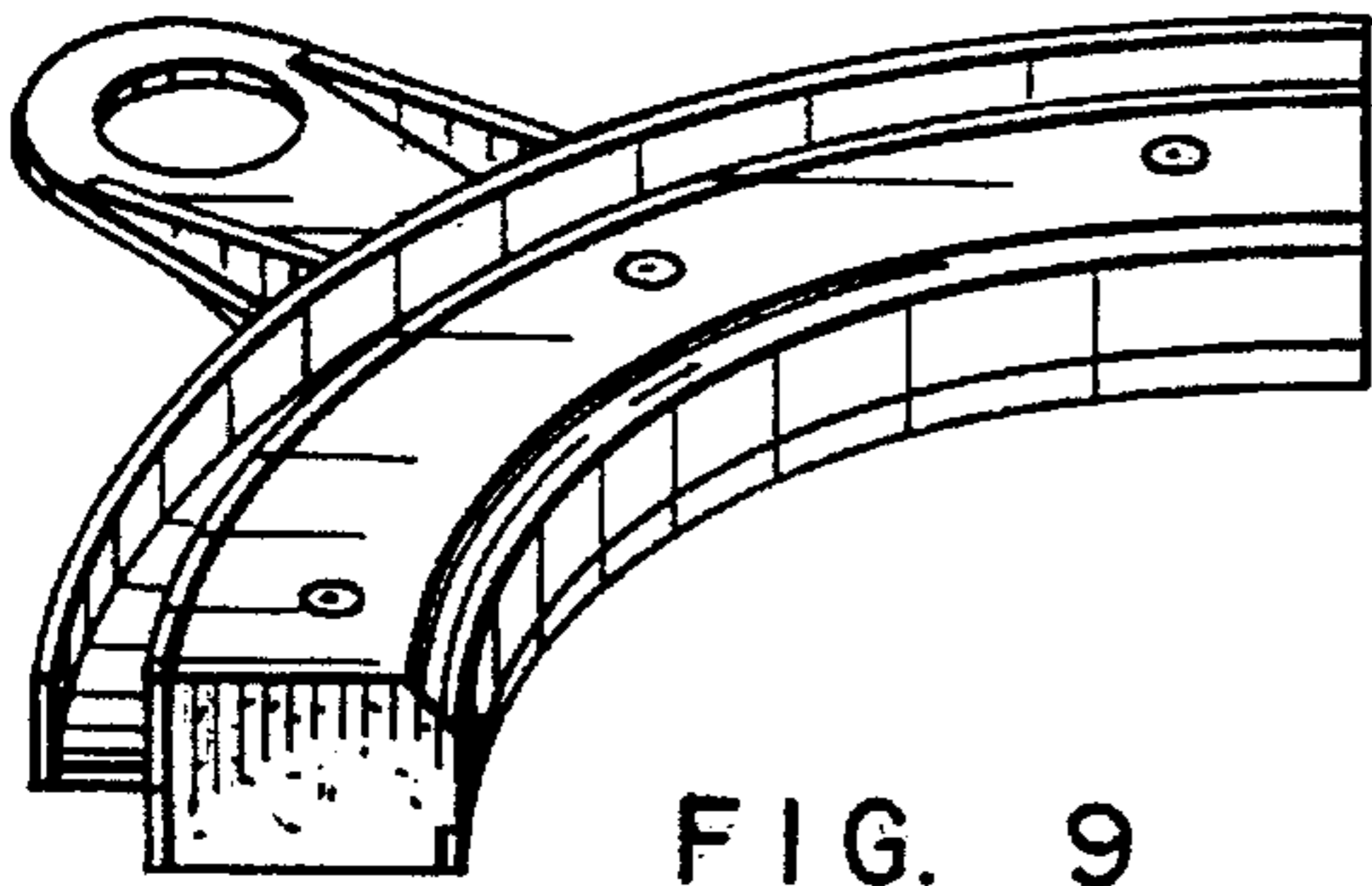

FIG. 9

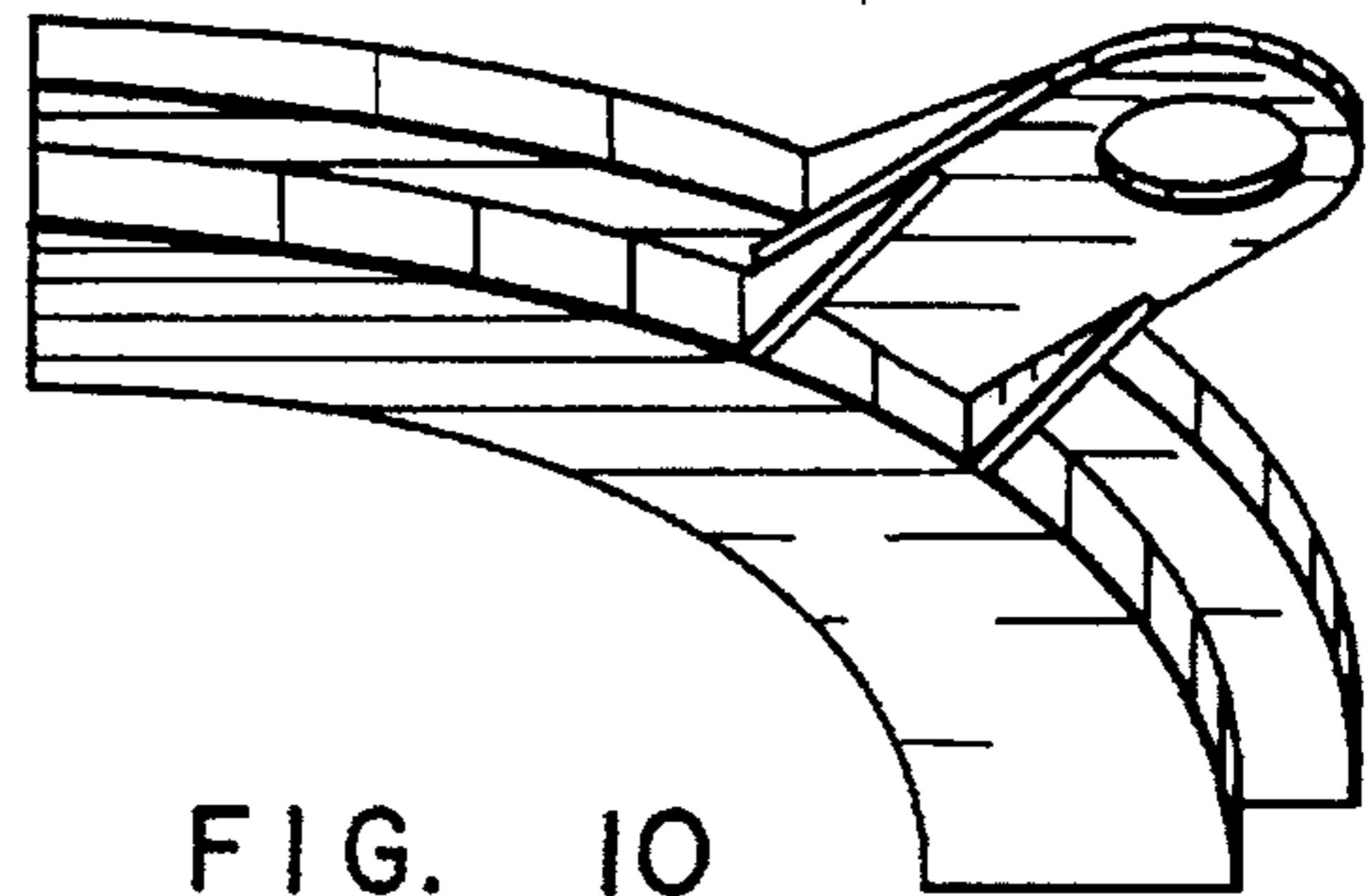

FIG. 10

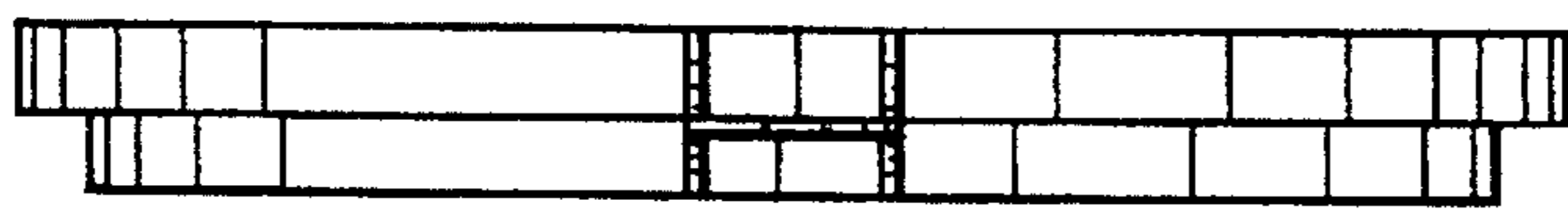

FIG. 14

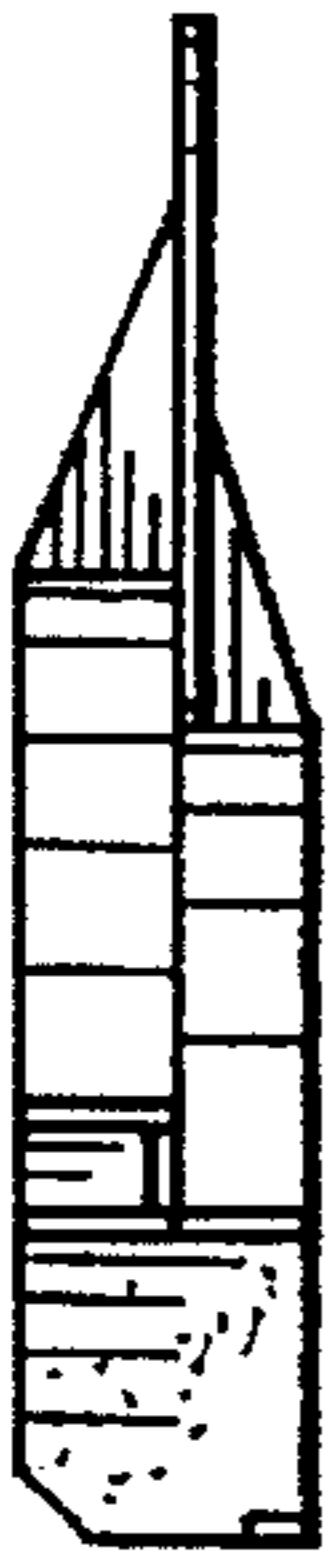

FIG. 15

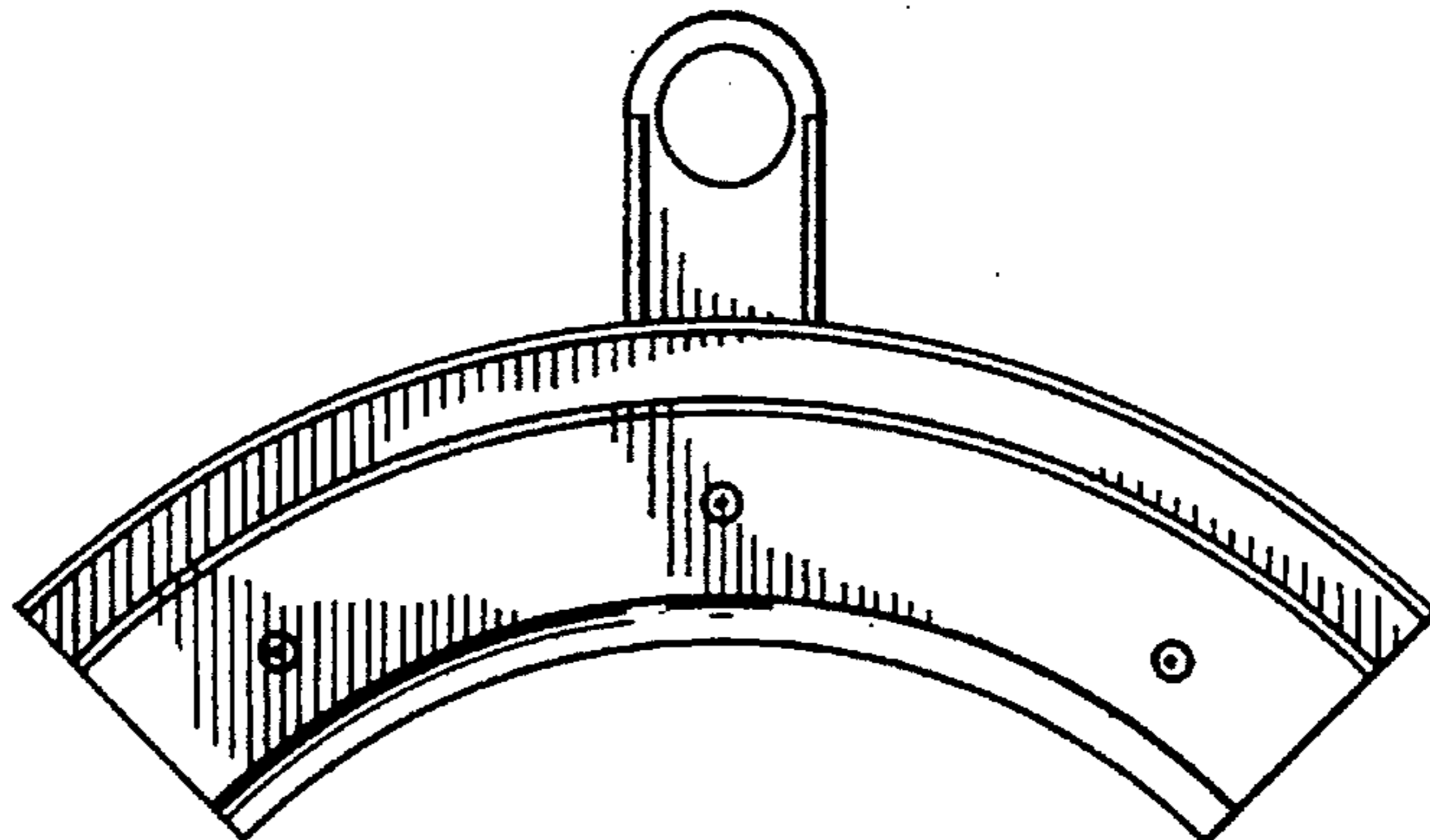

FIG. 11

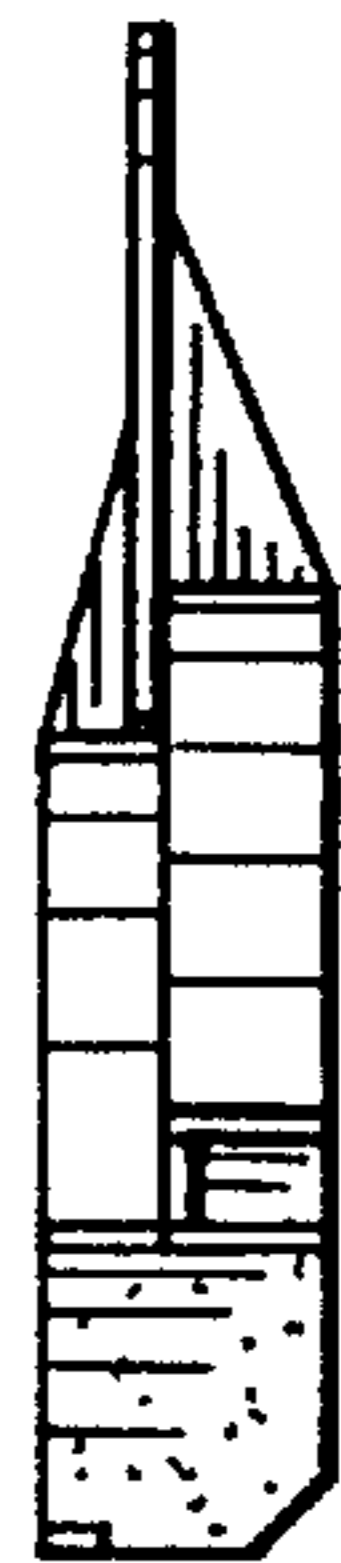

FIG. 16

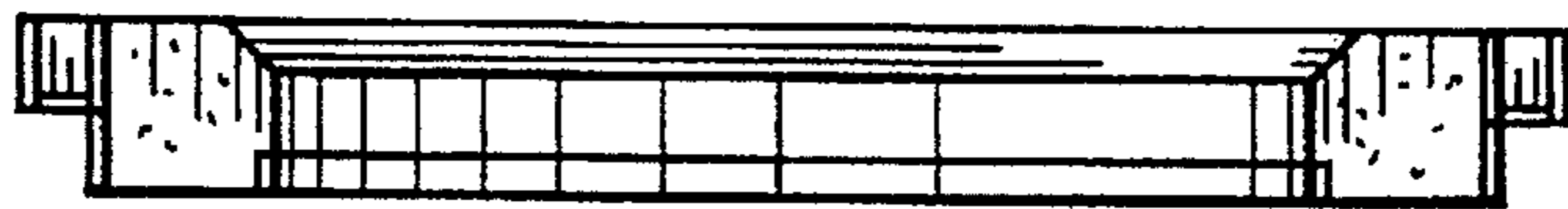

FIG. 13

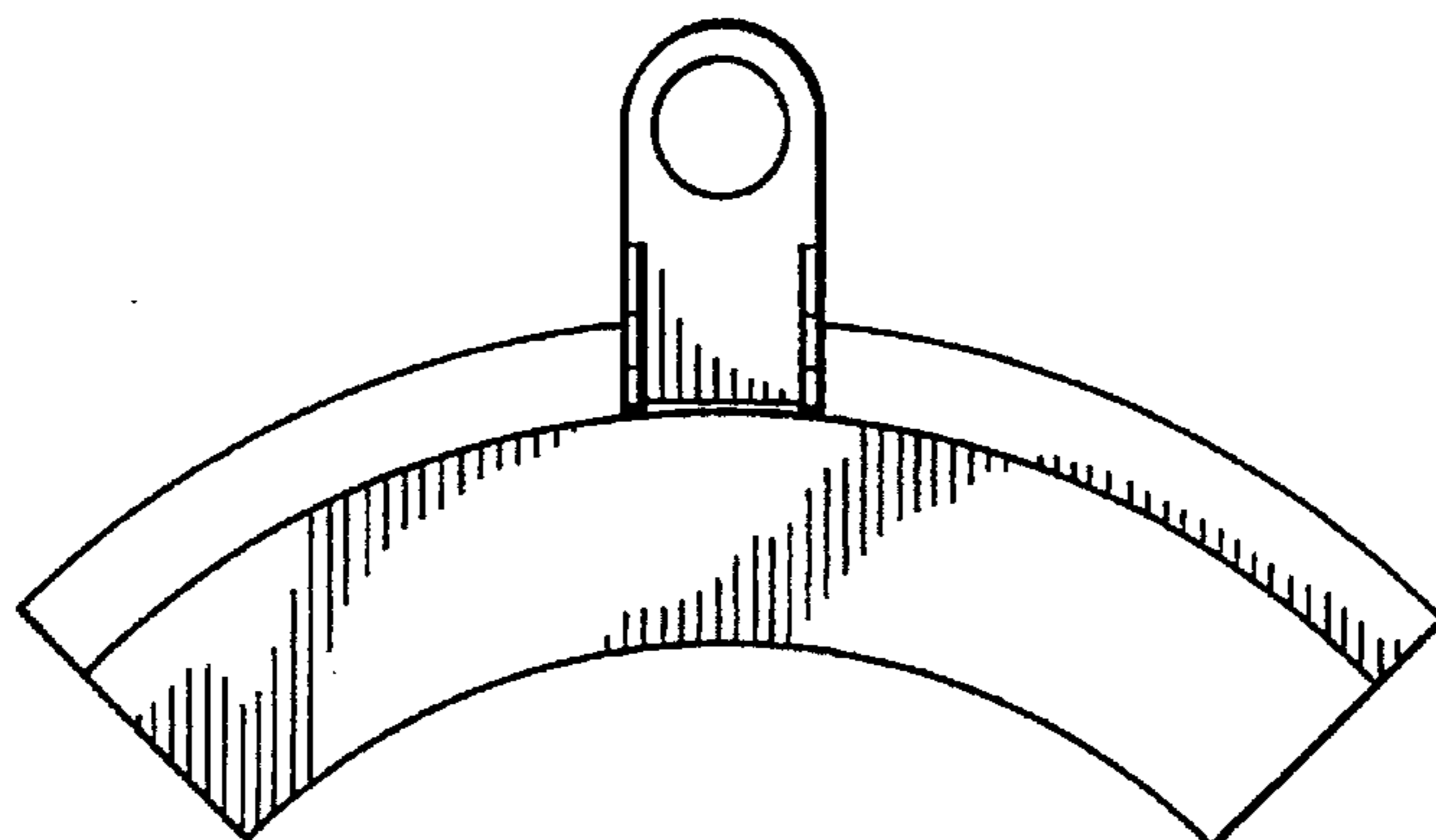

FIG. 12

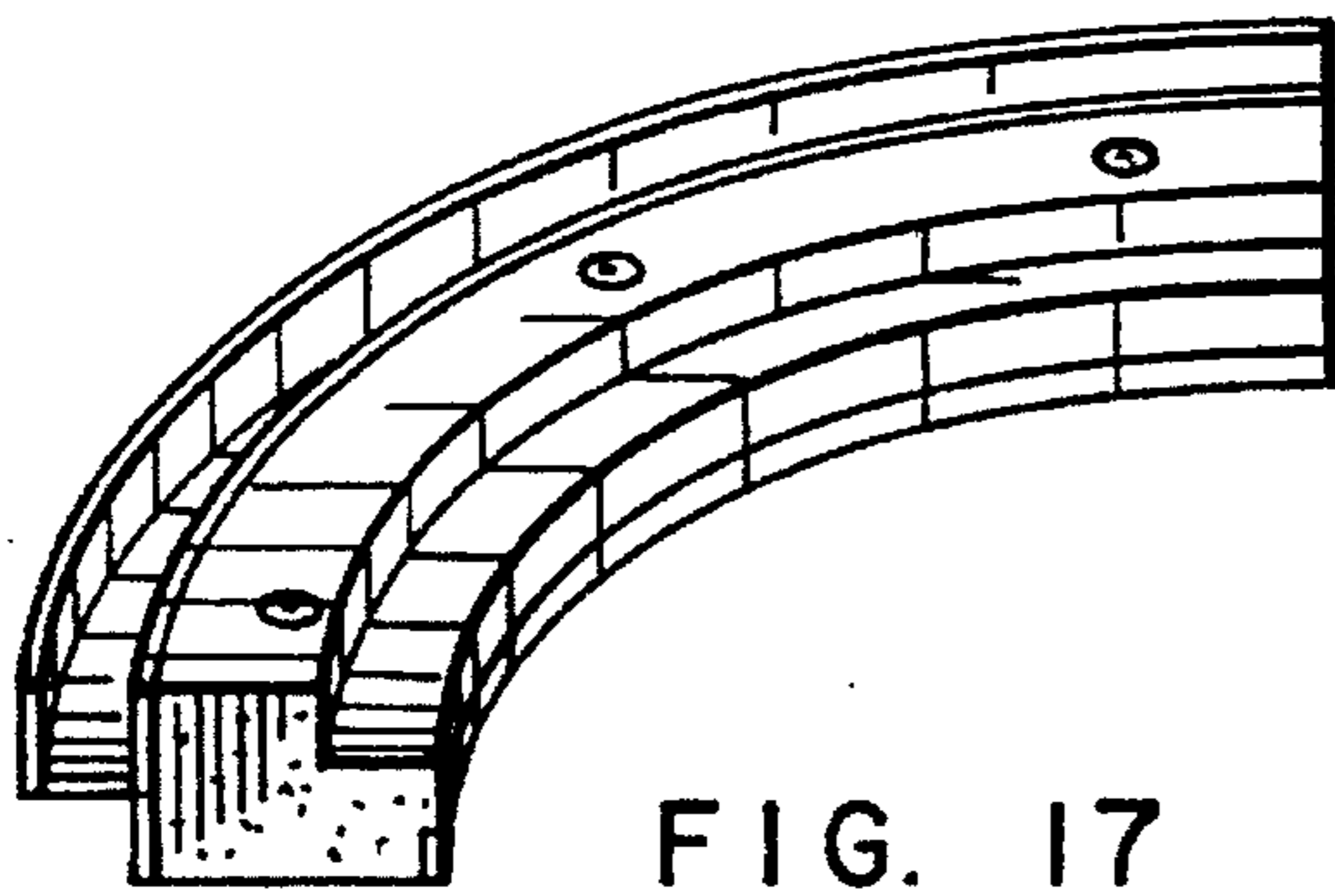

FIG. 17

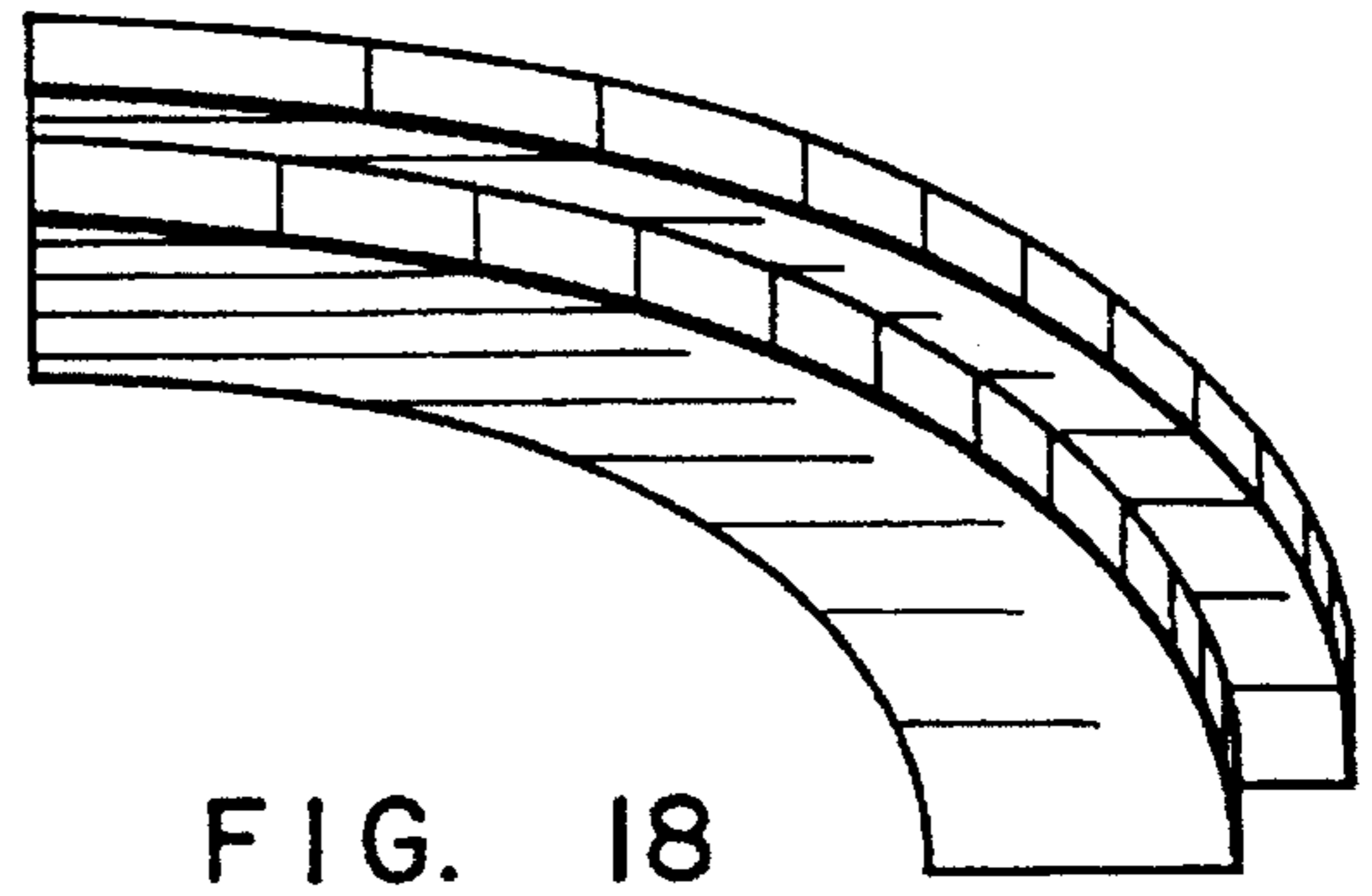

FIG. 18

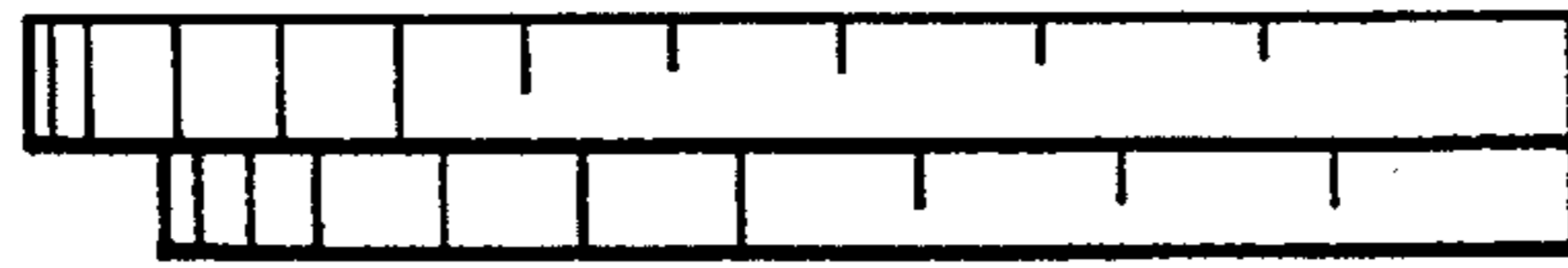

FIG. 22

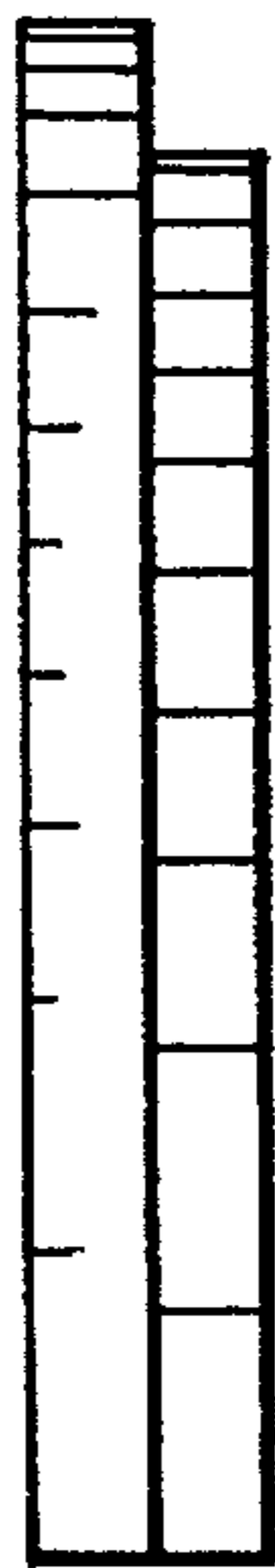

FIG. 23

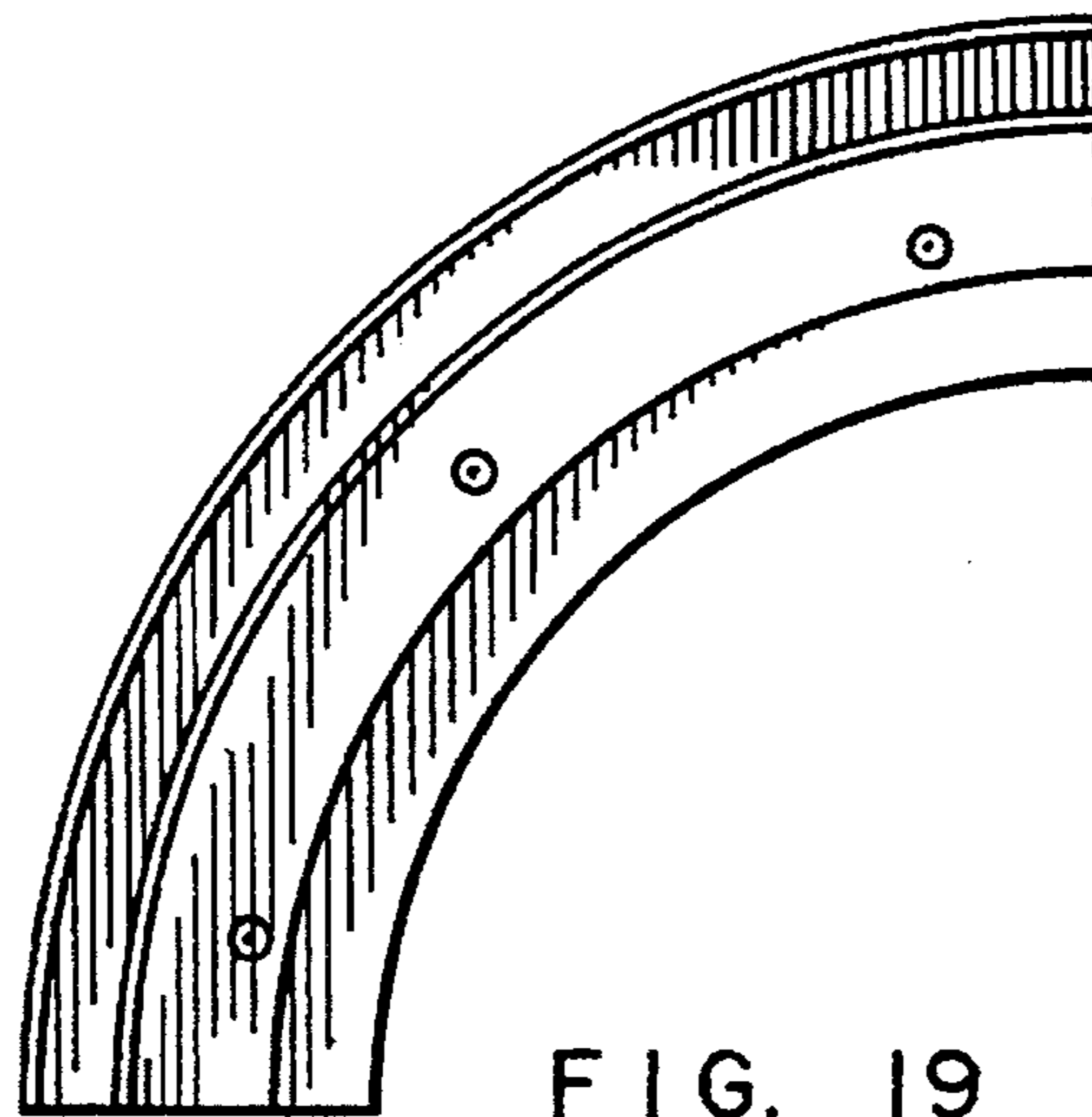

FIG. 19

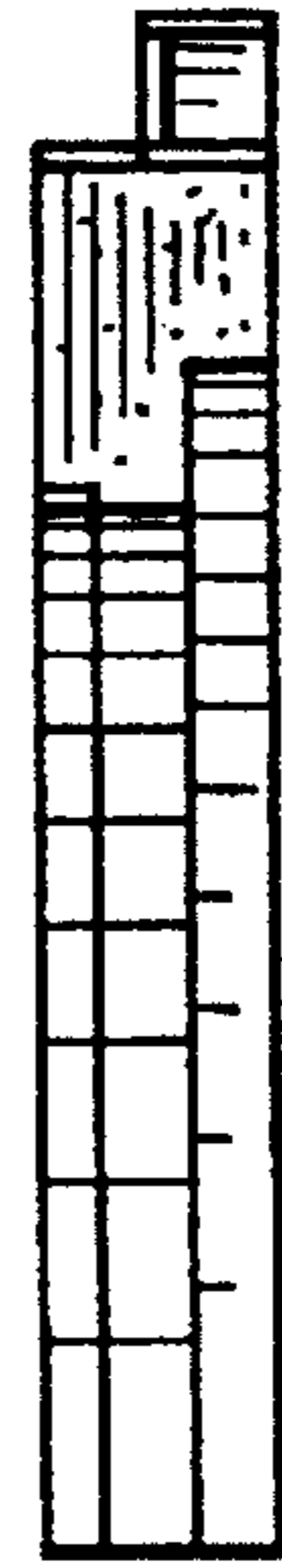

FIG. 24

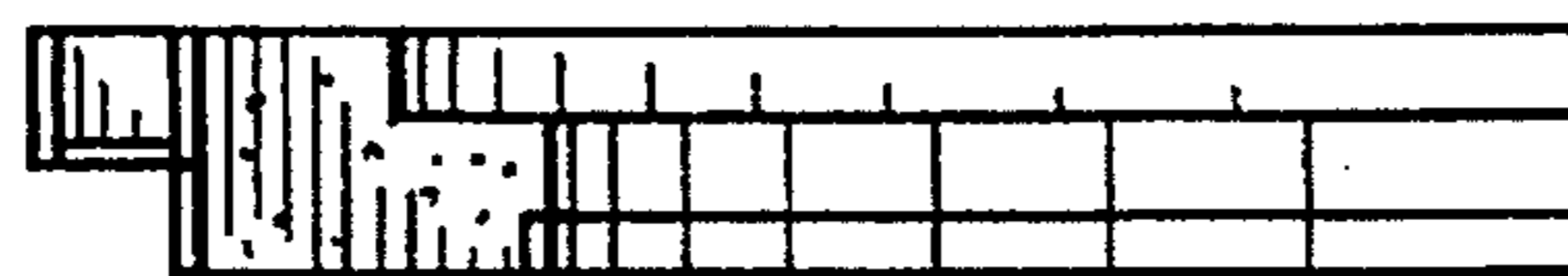

FIG. 21

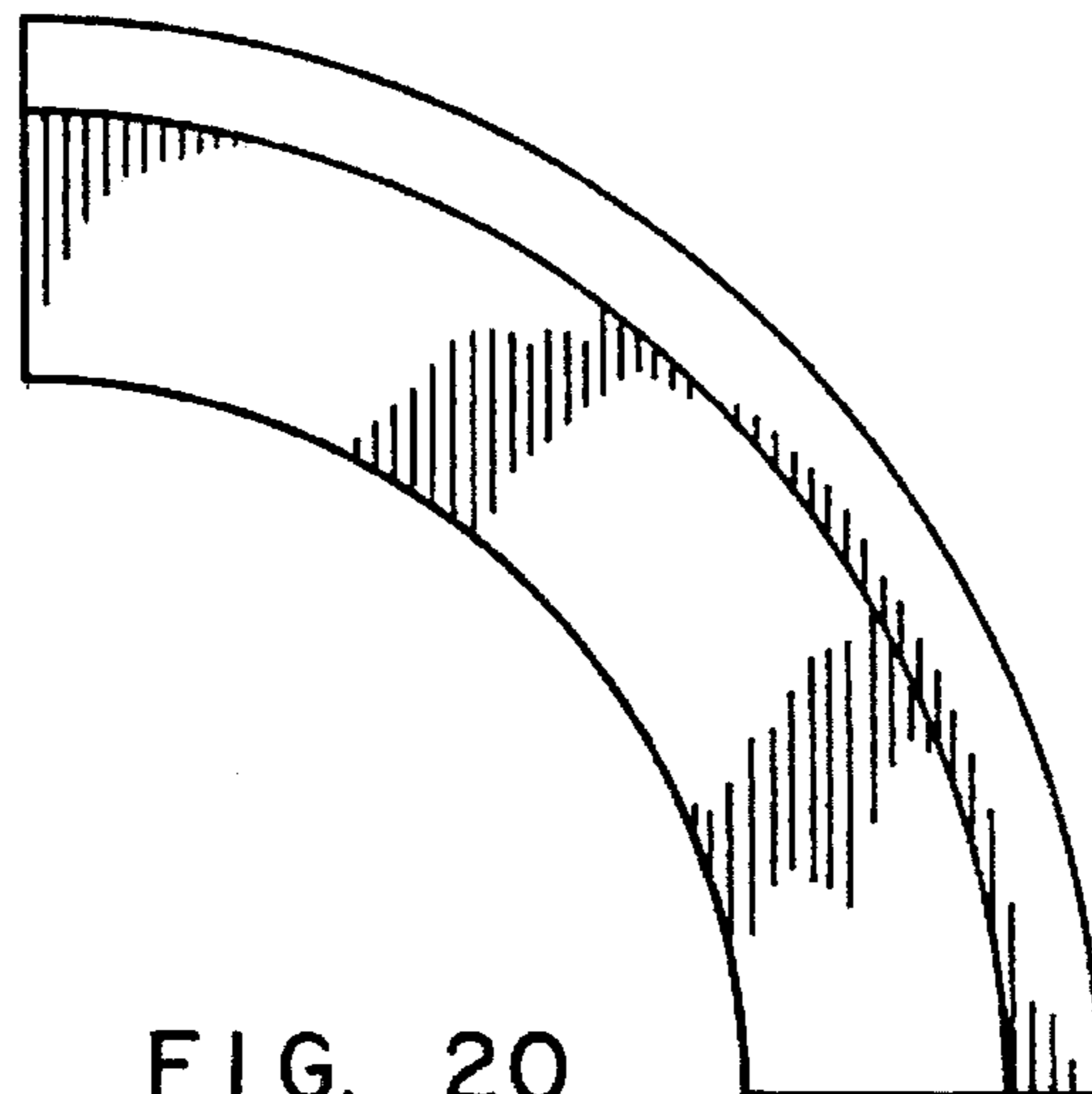

FIG. 20

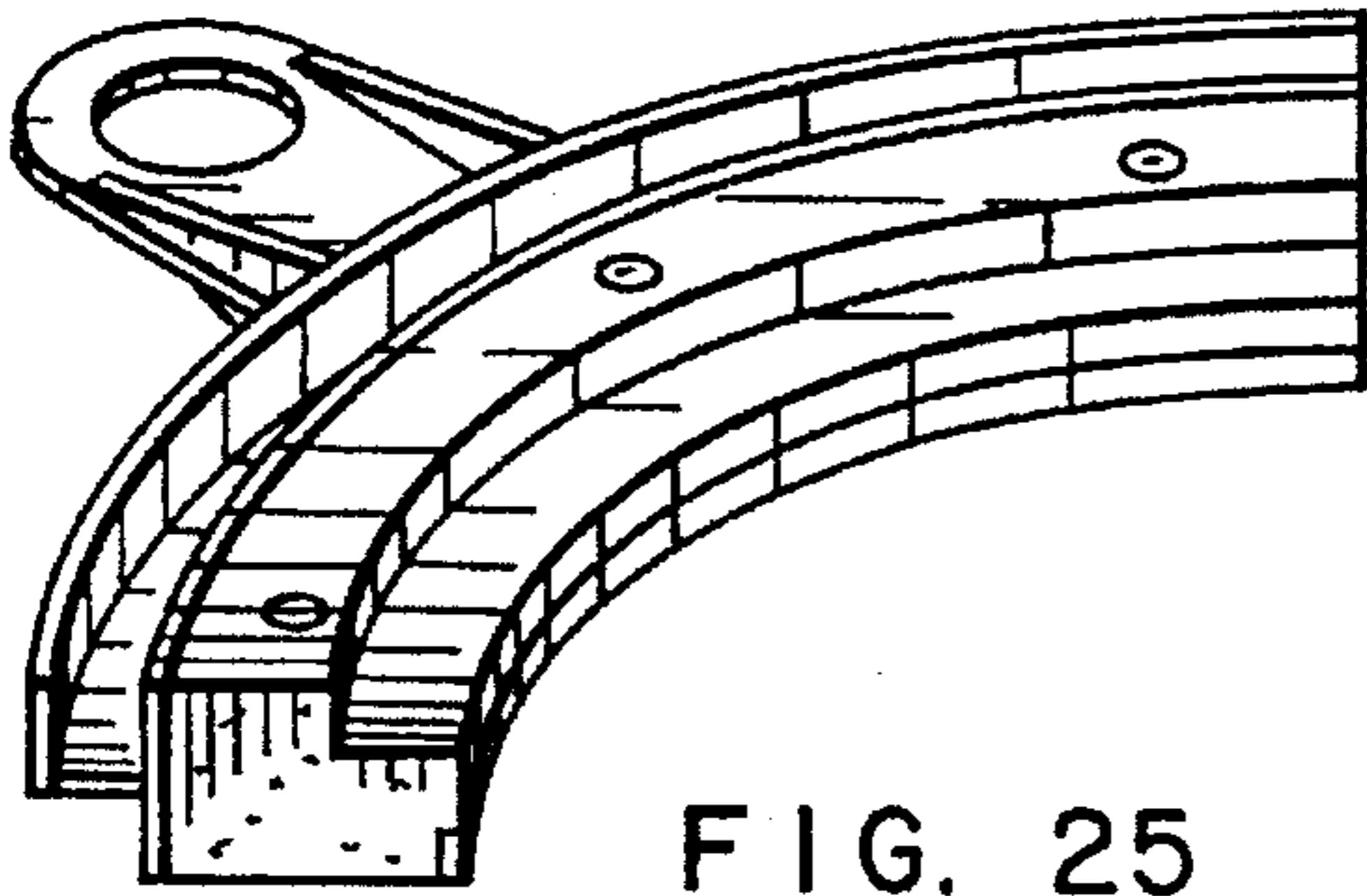

FIG. 25

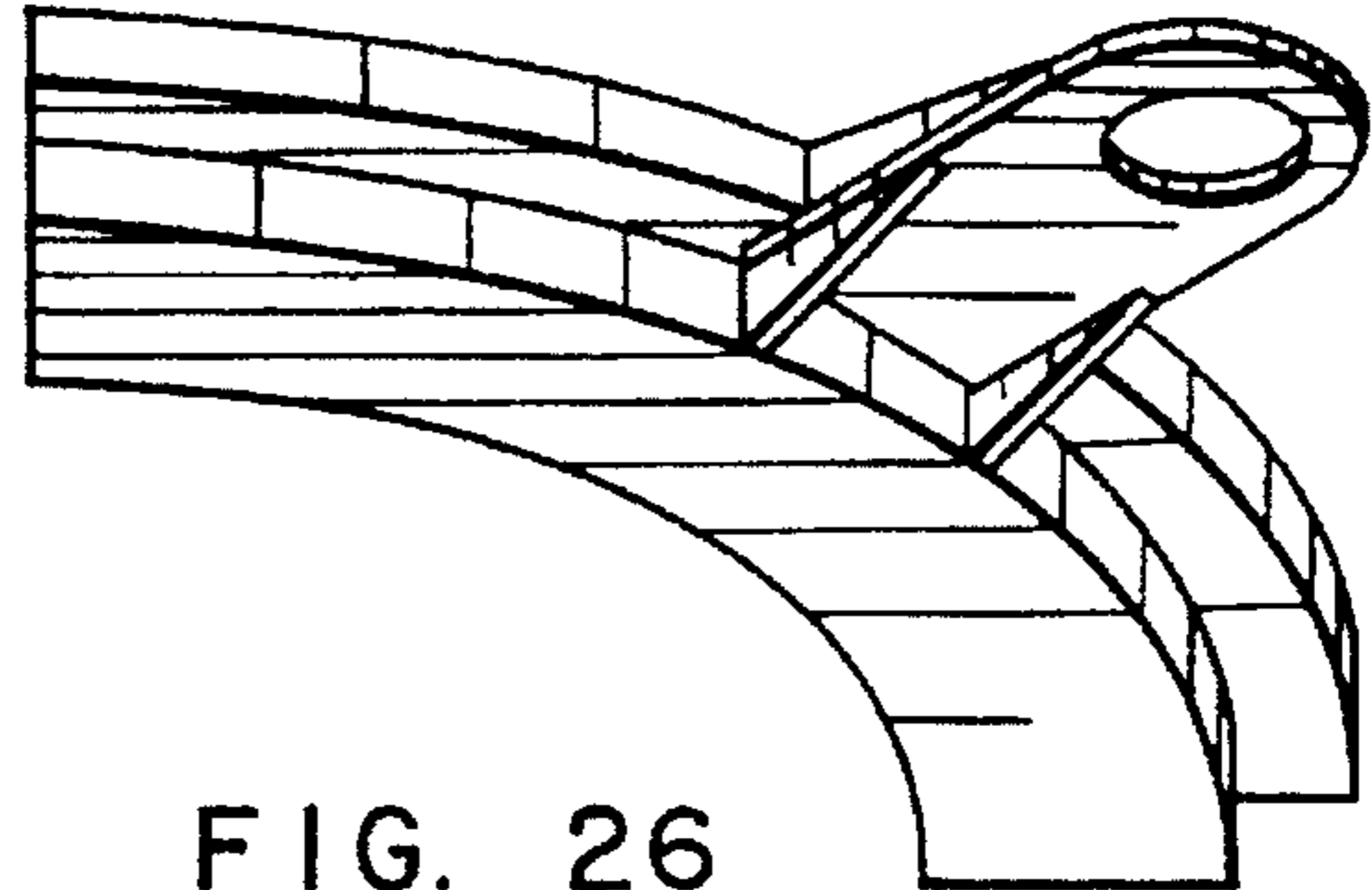

FIG. 26



FIG. 28

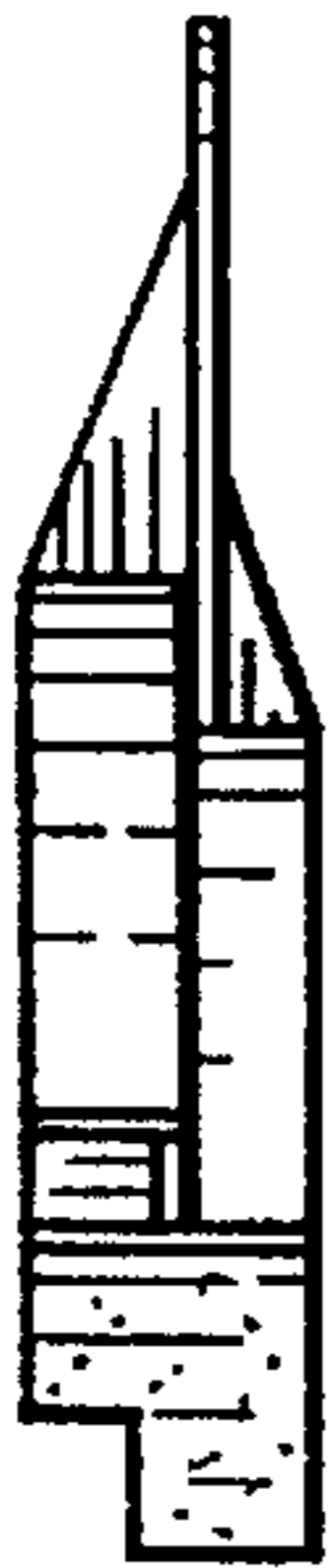

FIG. 31

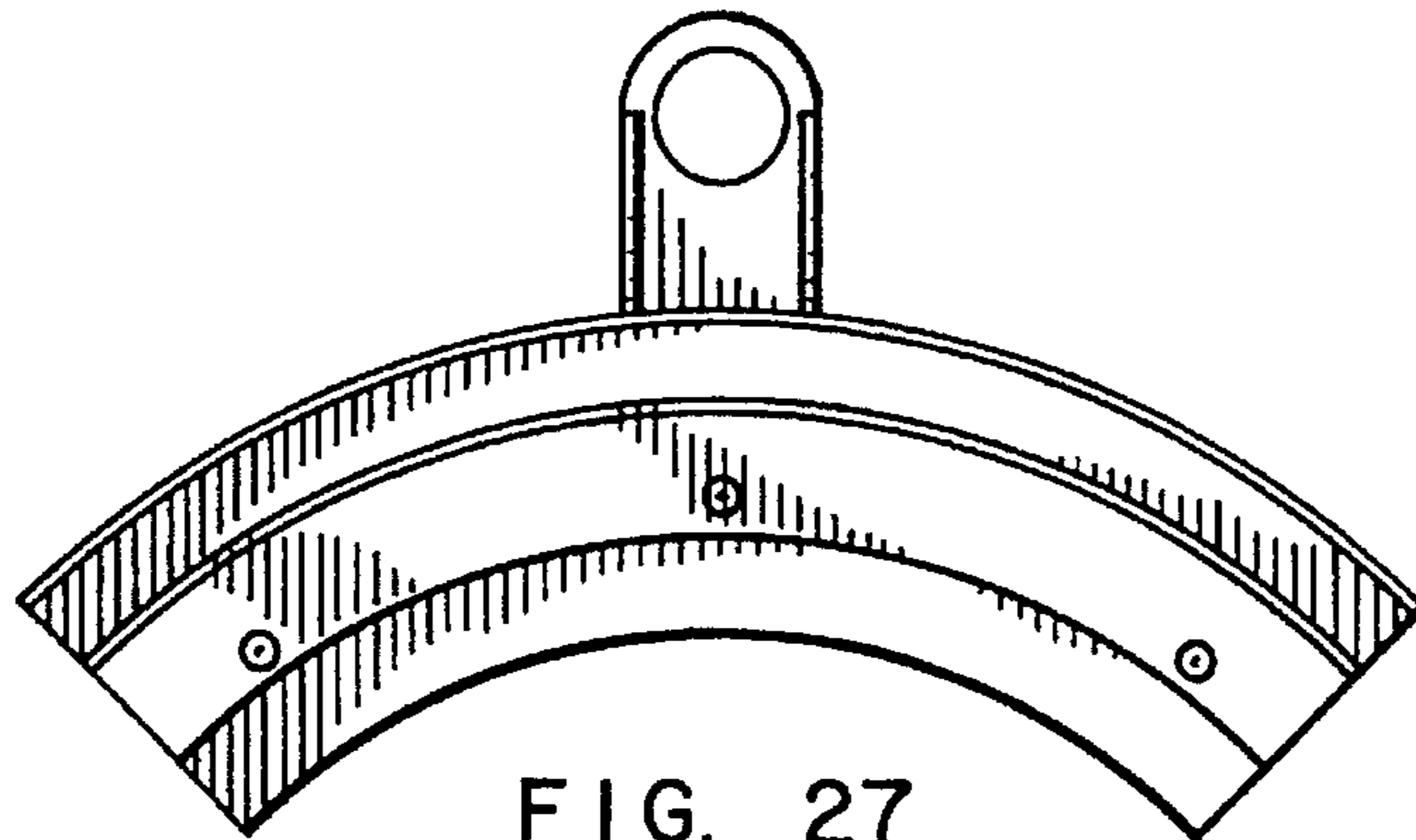

FIG. 27



FIG. 32



FIG. 29

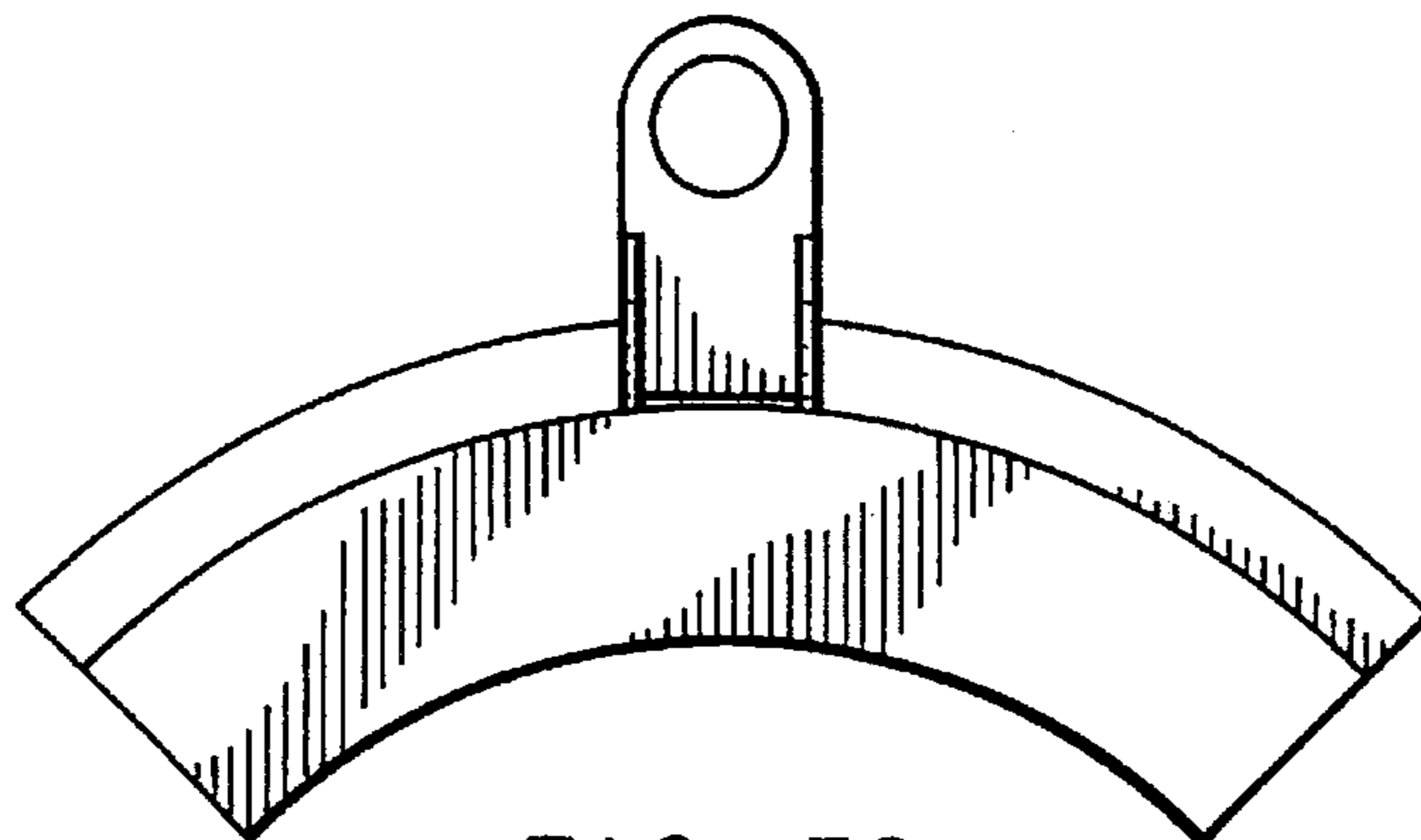

FIG. 30

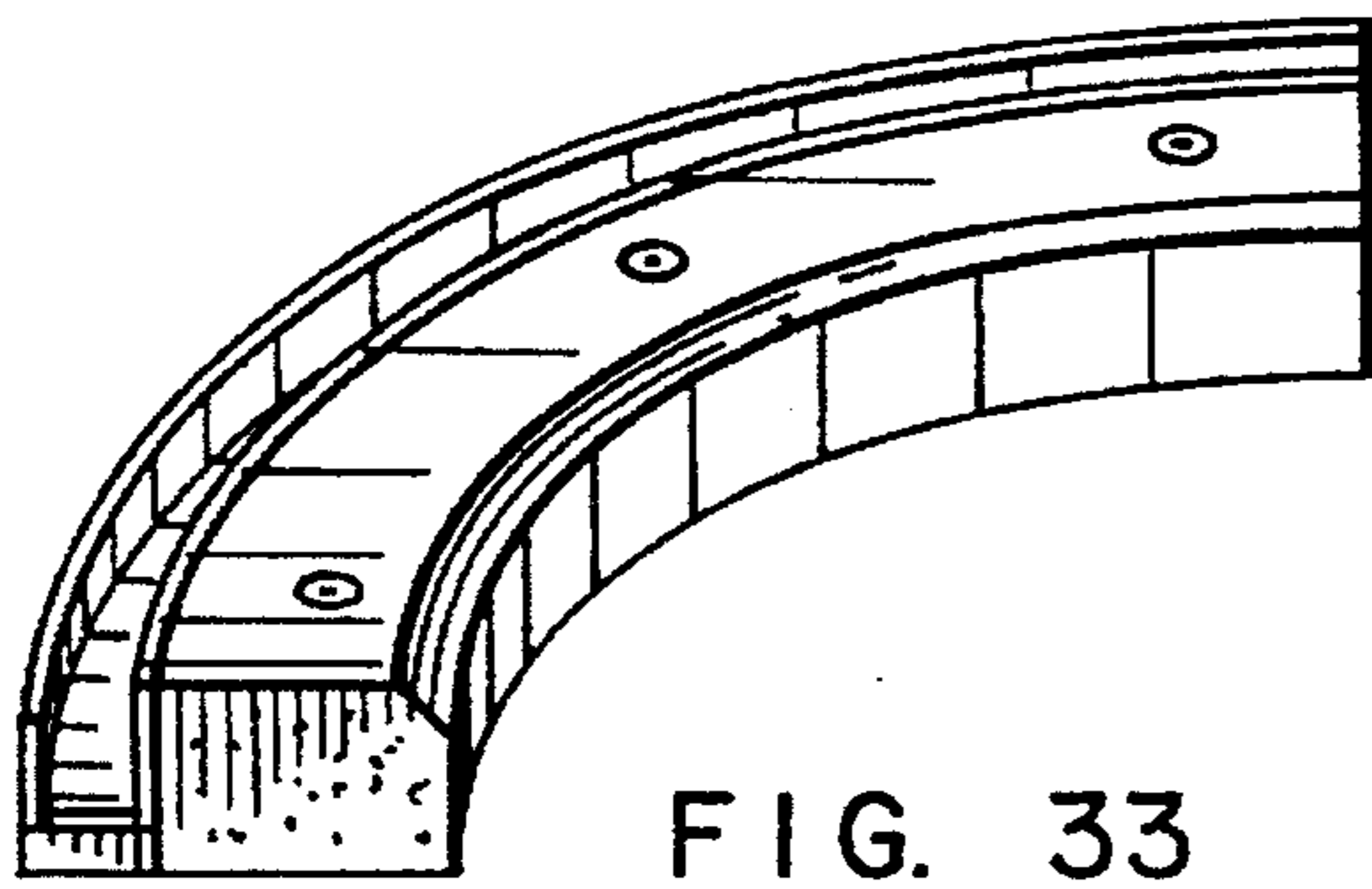

FIG. 33

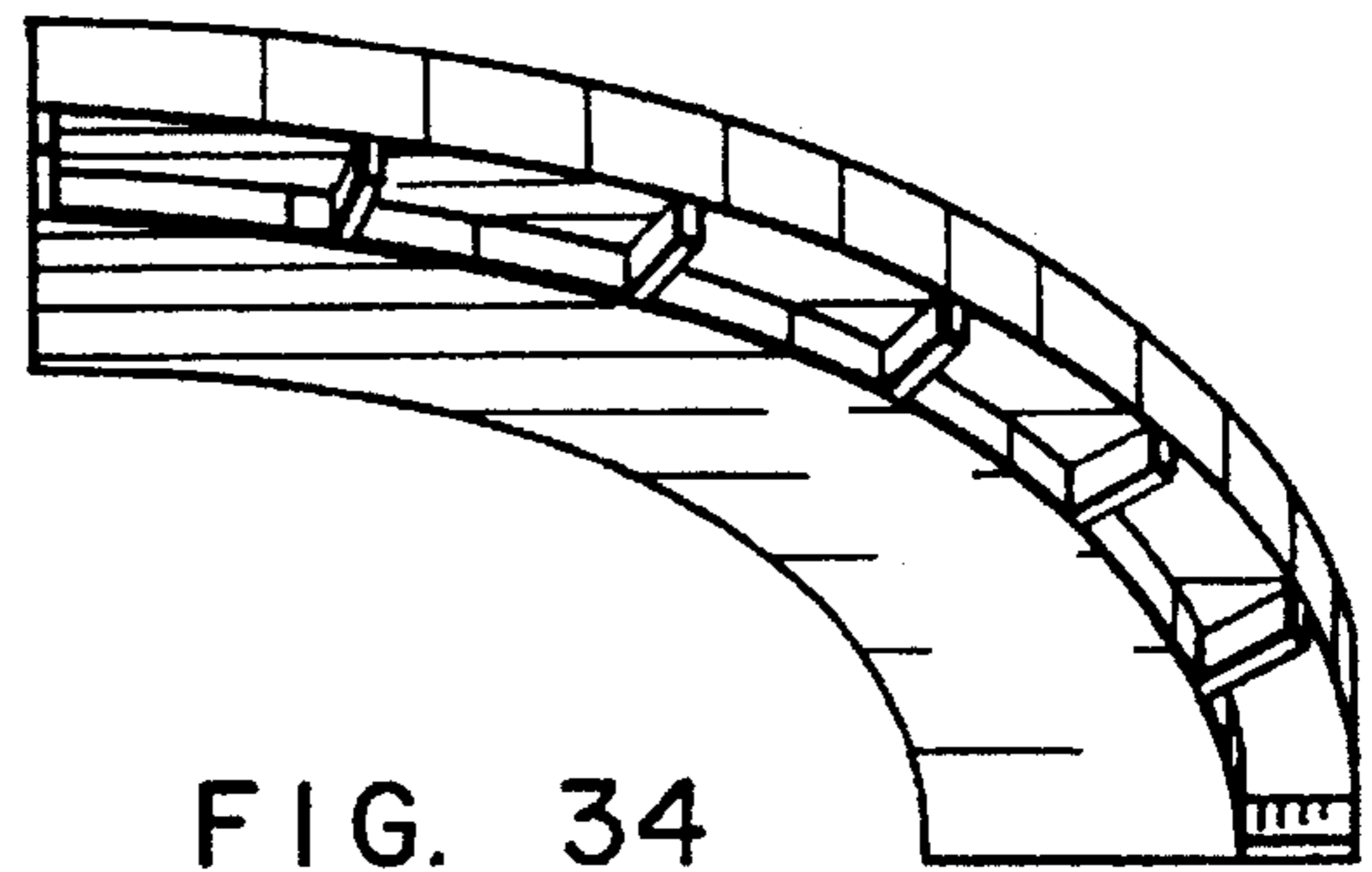

FIG. 34



FIG. 38

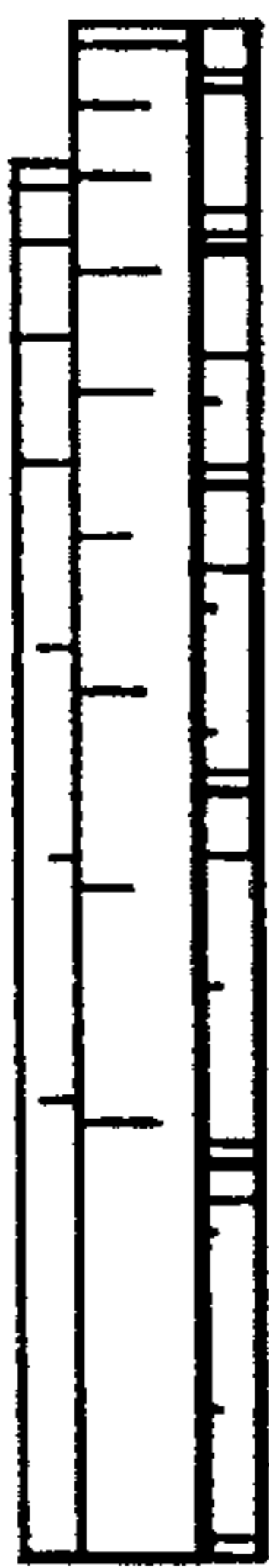

FIG. 39

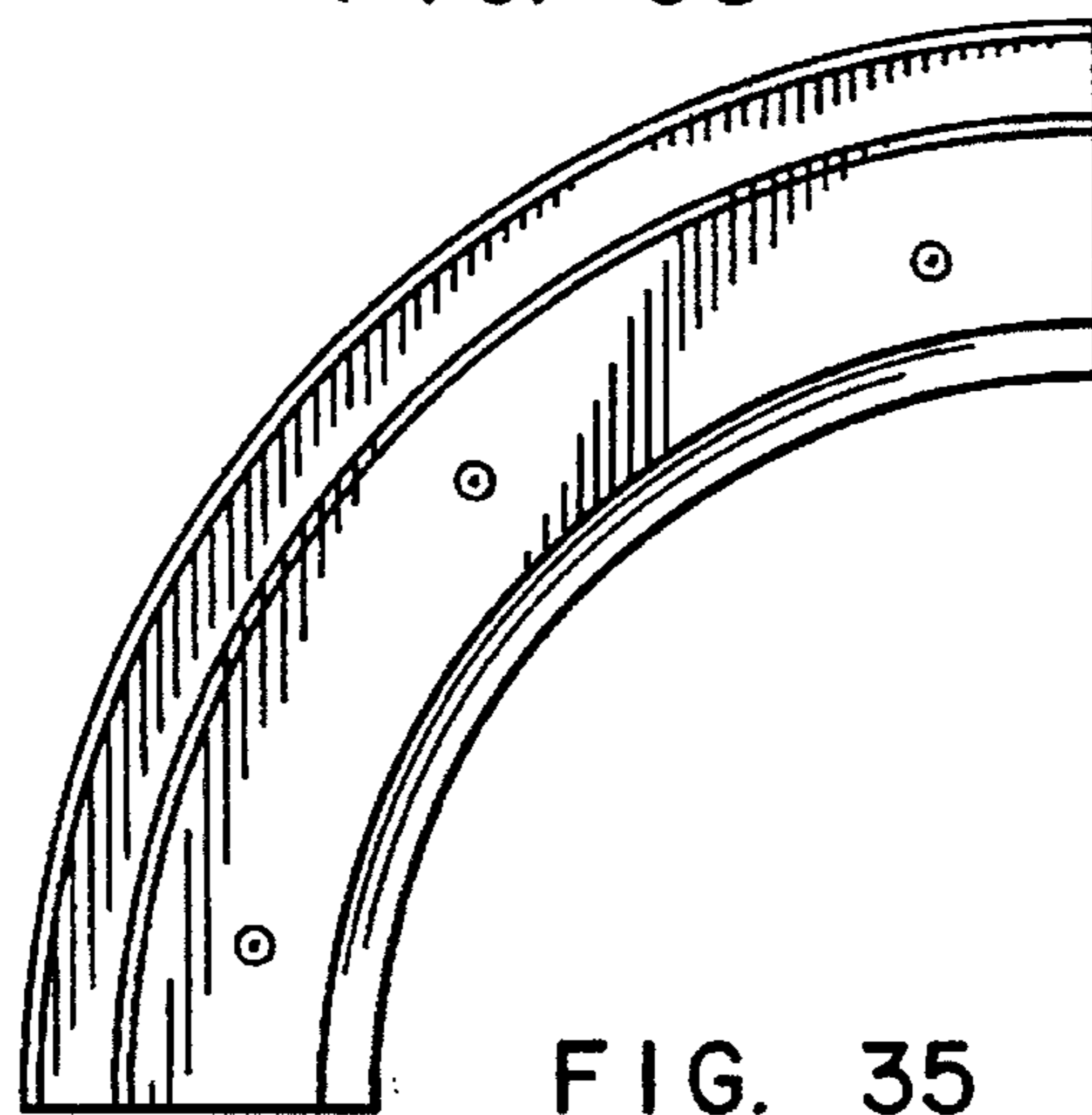

FIG. 35



FIG. 40



FIG. 37

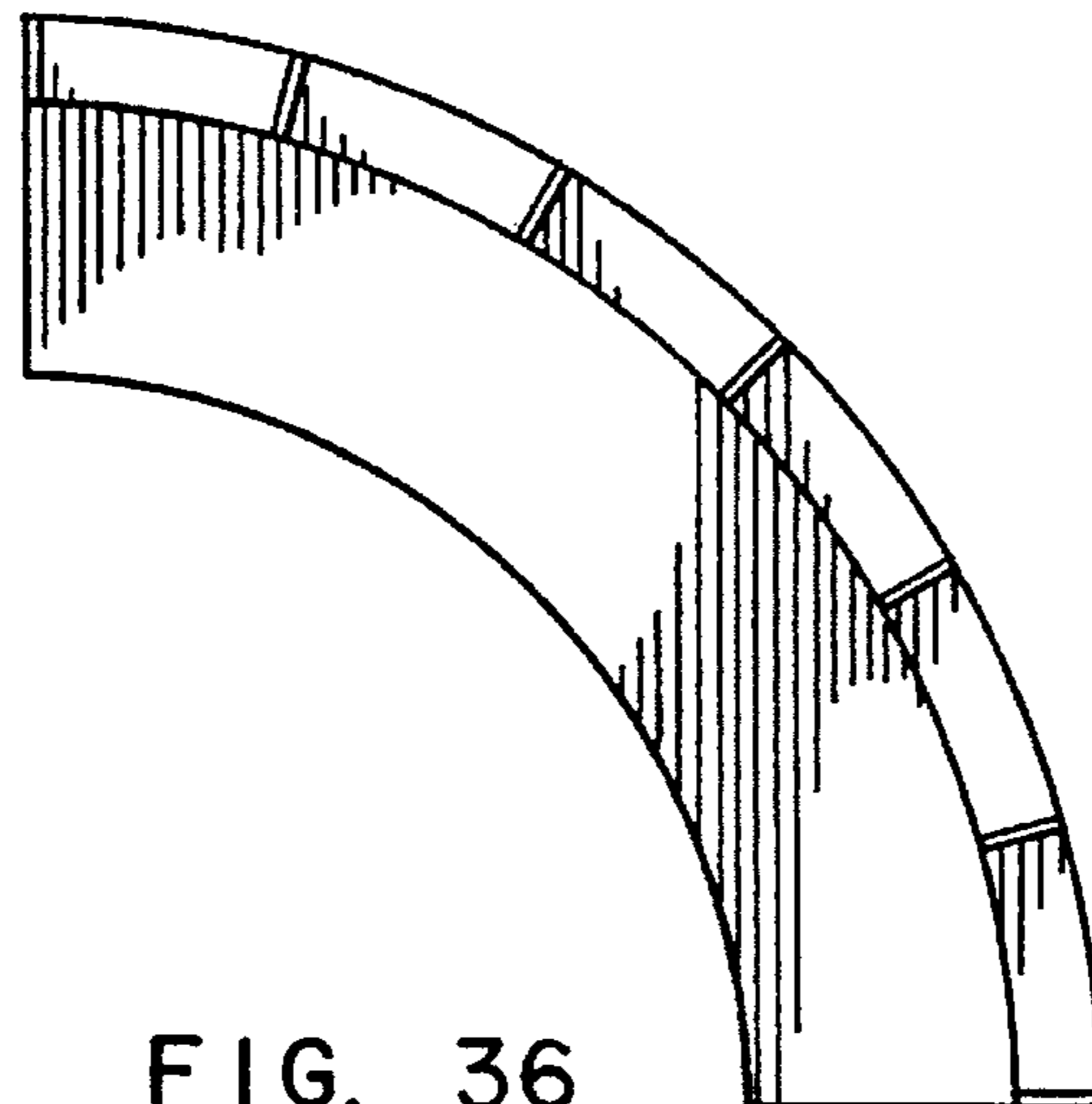

FIG. 36

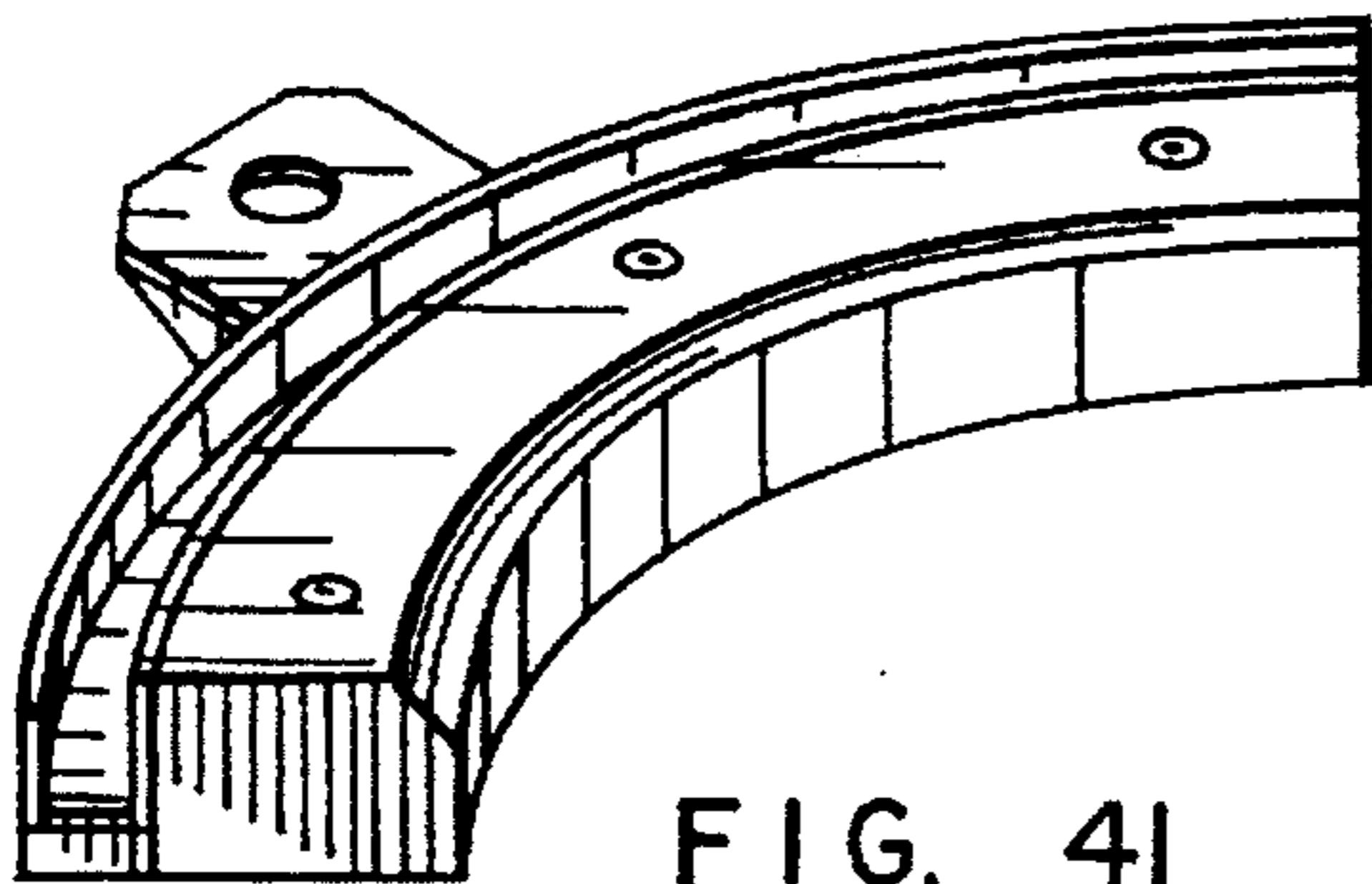

FIG. 41

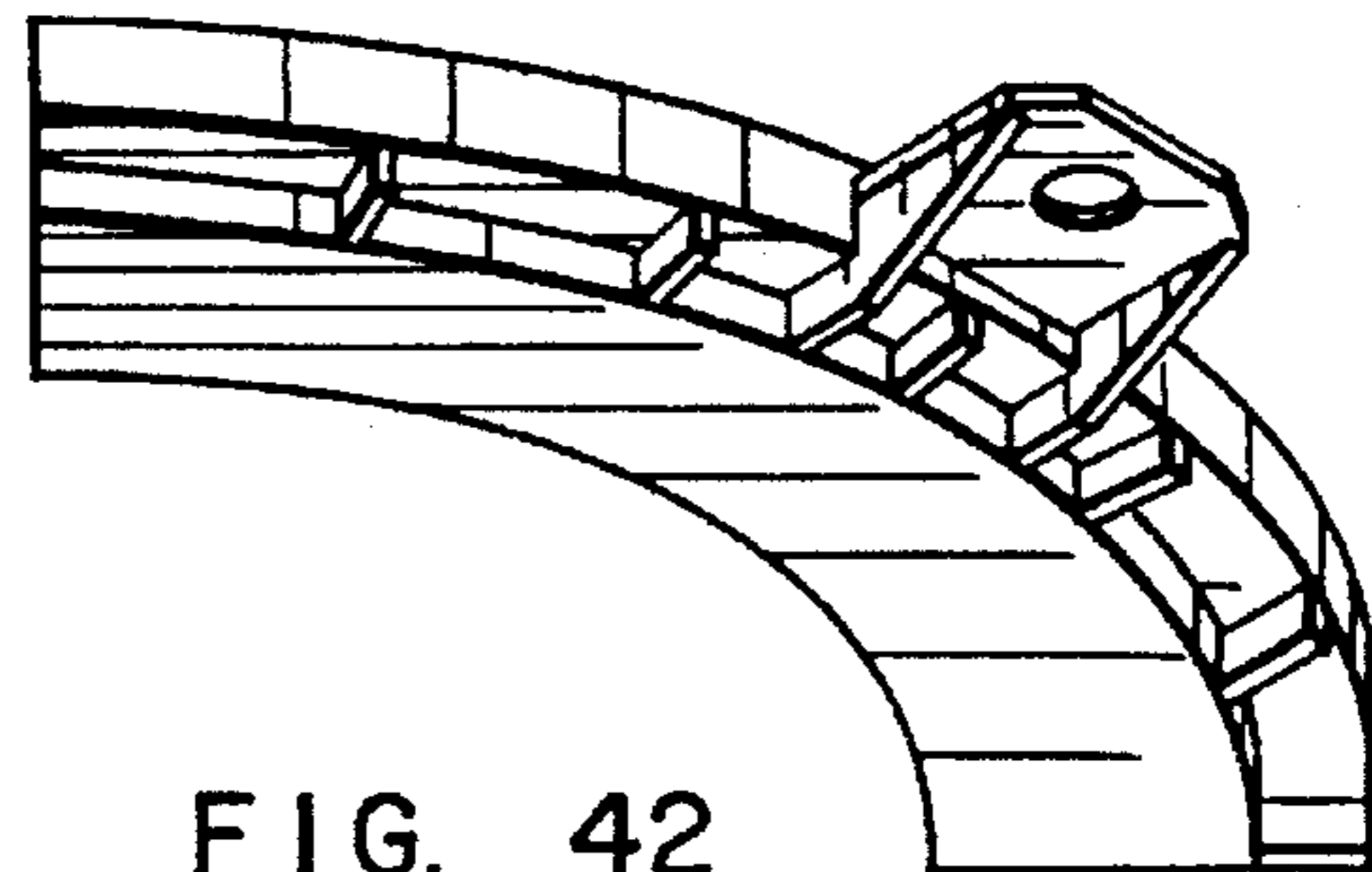

FIG. 42



FIG. 44

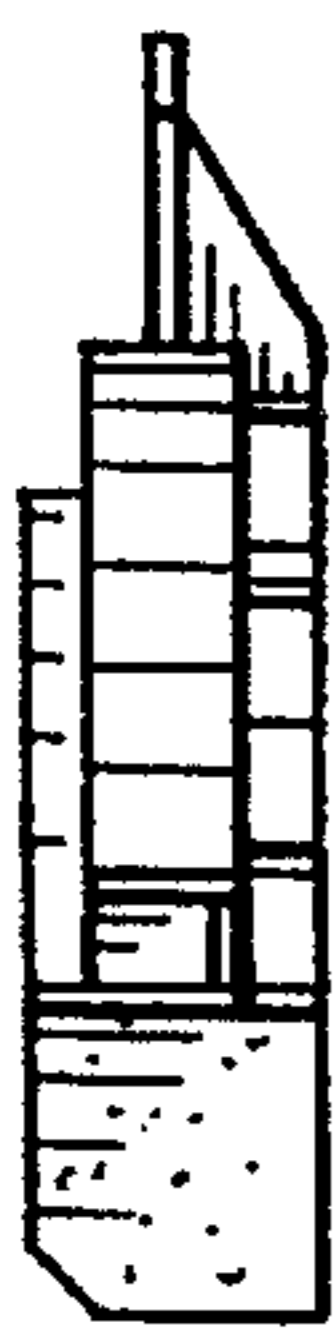

FIG. 47

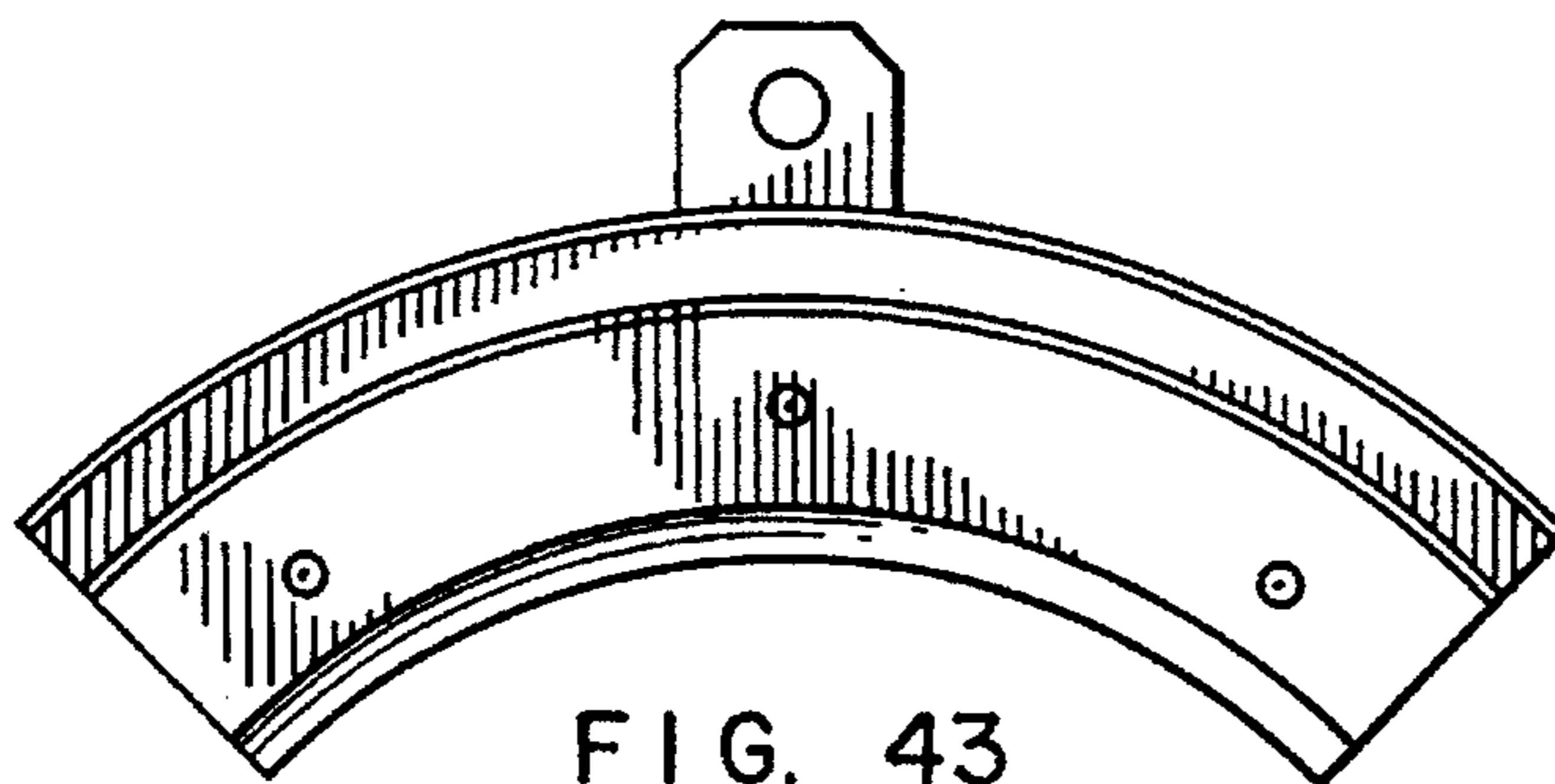

FIG. 43

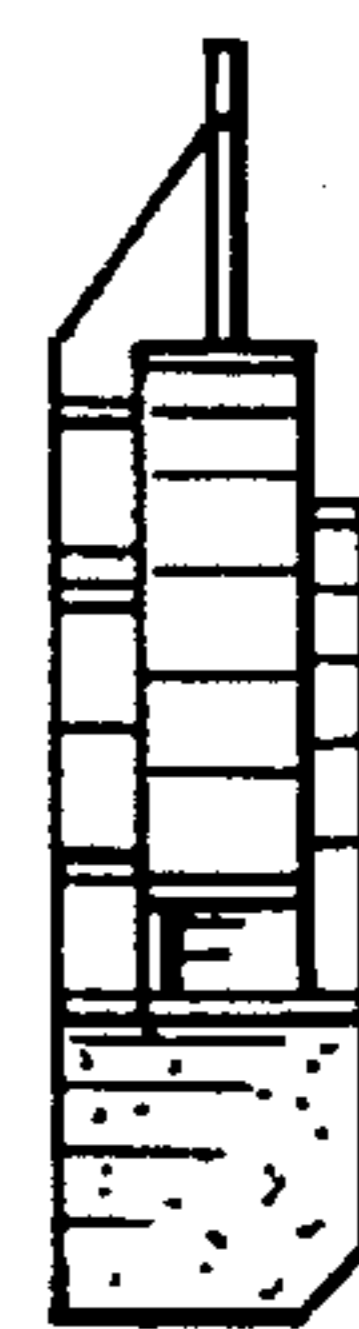

FIG. 48

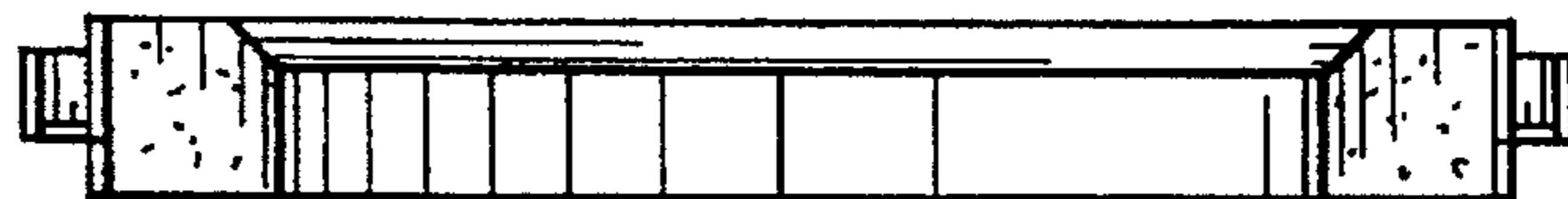

FIG. 45

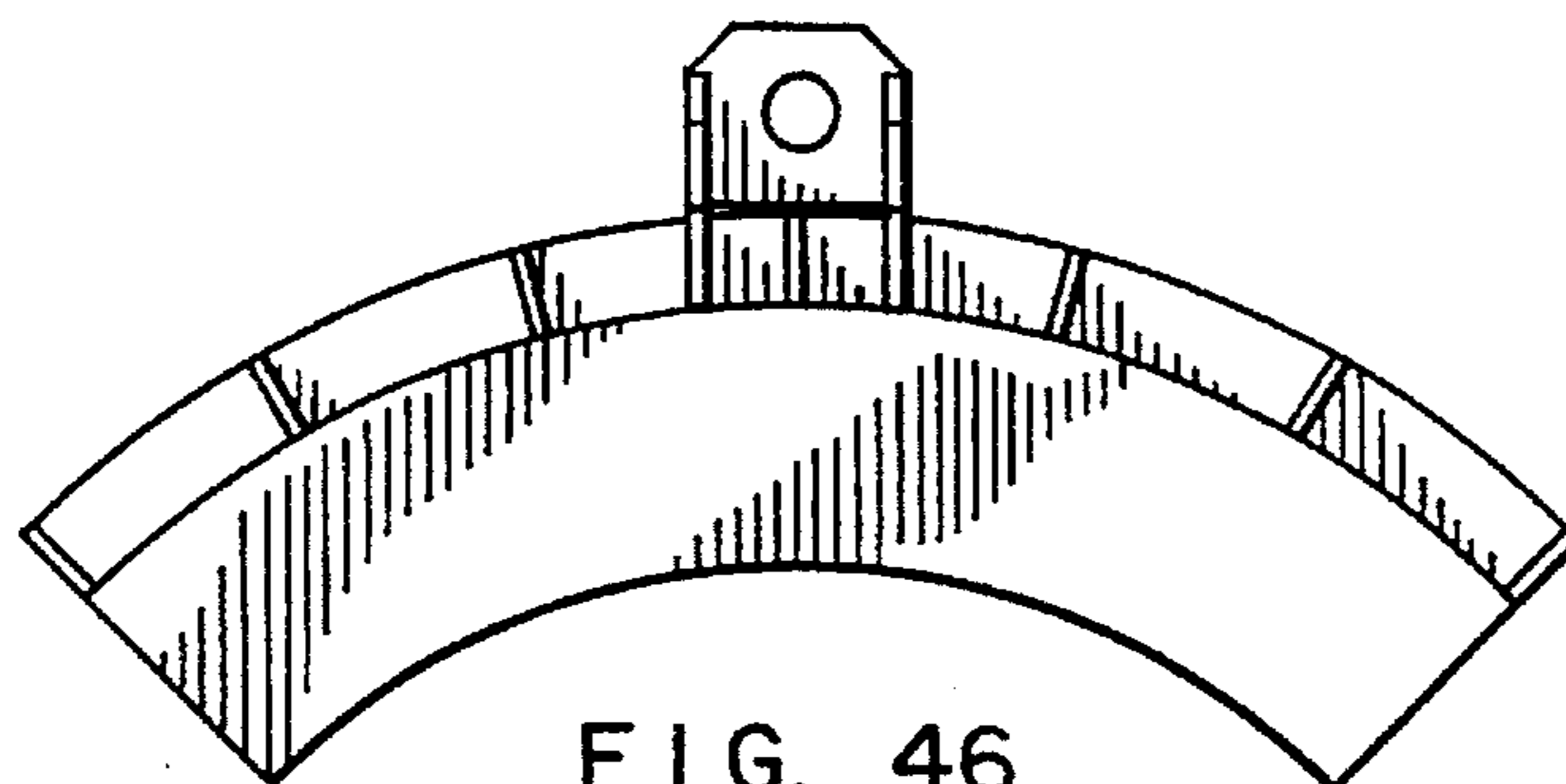

FIG. 46