



US00D382278S

United States Patent [19]

[11] Patent Number: Des. 382,278

Jantz

[45] Date of Patent: **Aug. 12, 1997

[54] SKID-STEER LOADER PIVOT WHEEL ARM DESIGN

Primary Examiner—Sandra L. Morris
Attorney, Agent, or Firm—Richard P. Stitt

[76] Inventor: Kirby L. Jantz, 720 N. Anna, Wichita, Kans. 67212

[57] CLAIM

[**] Term: 14 Years

The ornamental design for a skid-steer loader pivot wheel arm design, as shown and described.

[21] Appl. No.: 57,231

DESCRIPTION

[22] Filed: Jul. 19, 1996

FIG. 1 is a left side and front perspective view of the skid-steer loader pivot wheel arm design showing my new design;

[51] LOC (6) Cl. 15-04

FIG. 2 is a front elevational view thereof;

[52] U.S. Cl. D15/28

FIG. 3 is a rear elevational view thereof;

[58] Field of Search D15/10, 22-26, D15/28; 180/89.1, 89.12, 900; 414/607, 685, 688; 37/403

FIG. 4 is a right side elevational view thereof;

FIG. 5 is a left side elevational view thereof;

FIG. 6 is a top plan view thereof; and,

FIG. 7 is a bottom plan view thereof.

[56] References Cited

The broken line showing of the skid-steer loader in FIG. 1 is for illustrative purposes only, and forms no part of the claimed design.

U.S. PATENT DOCUMENTS

4,910,891	3/1990	Martin et al.	37/403
5,054,989	10/1991	Fell	414/607
5,171,124	12/1992	Foster	414/685
5,538,389	7/1996	Stone	414/685

1 Claim, 2 Drawing Sheets

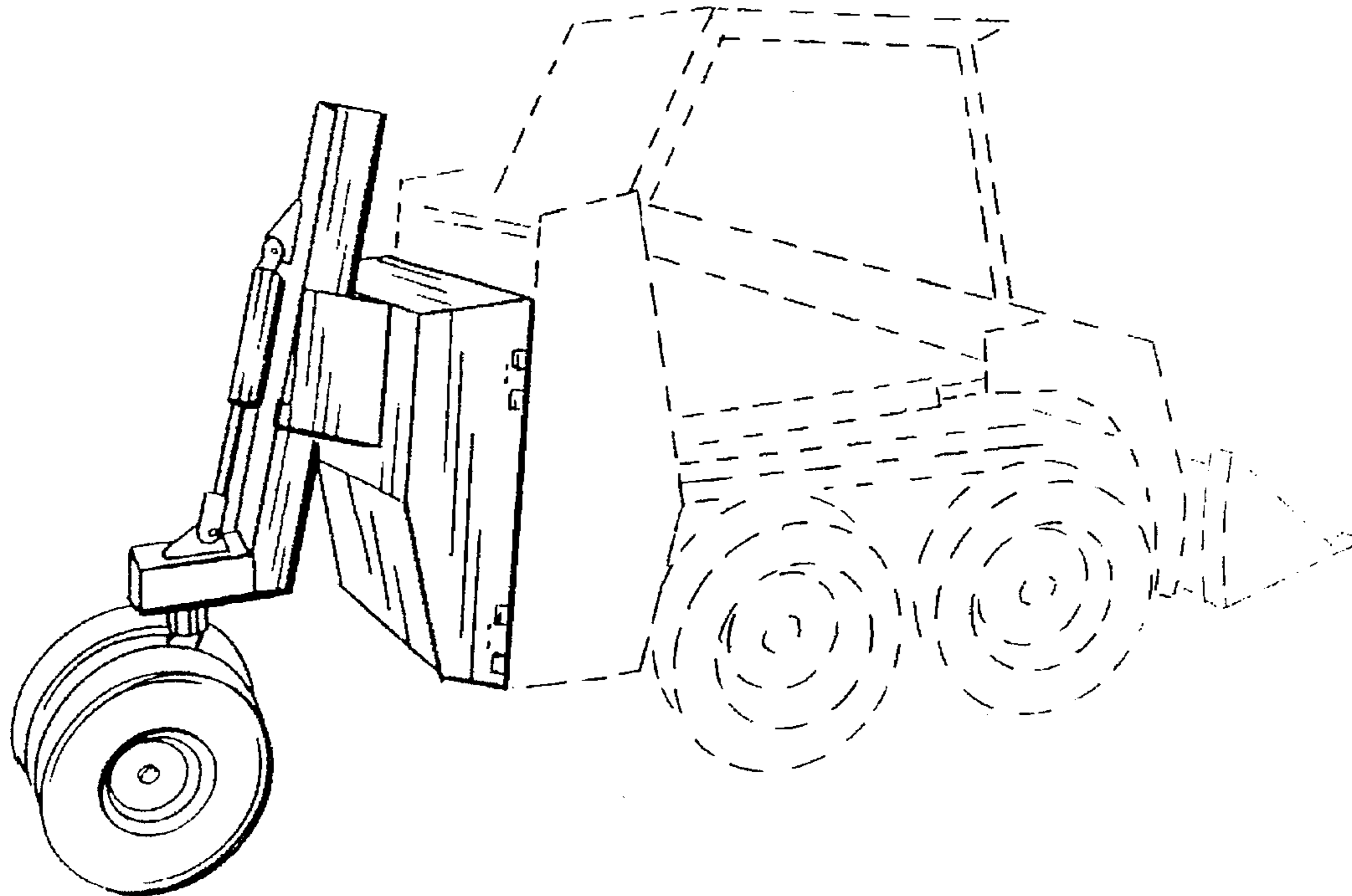

FIG. 1

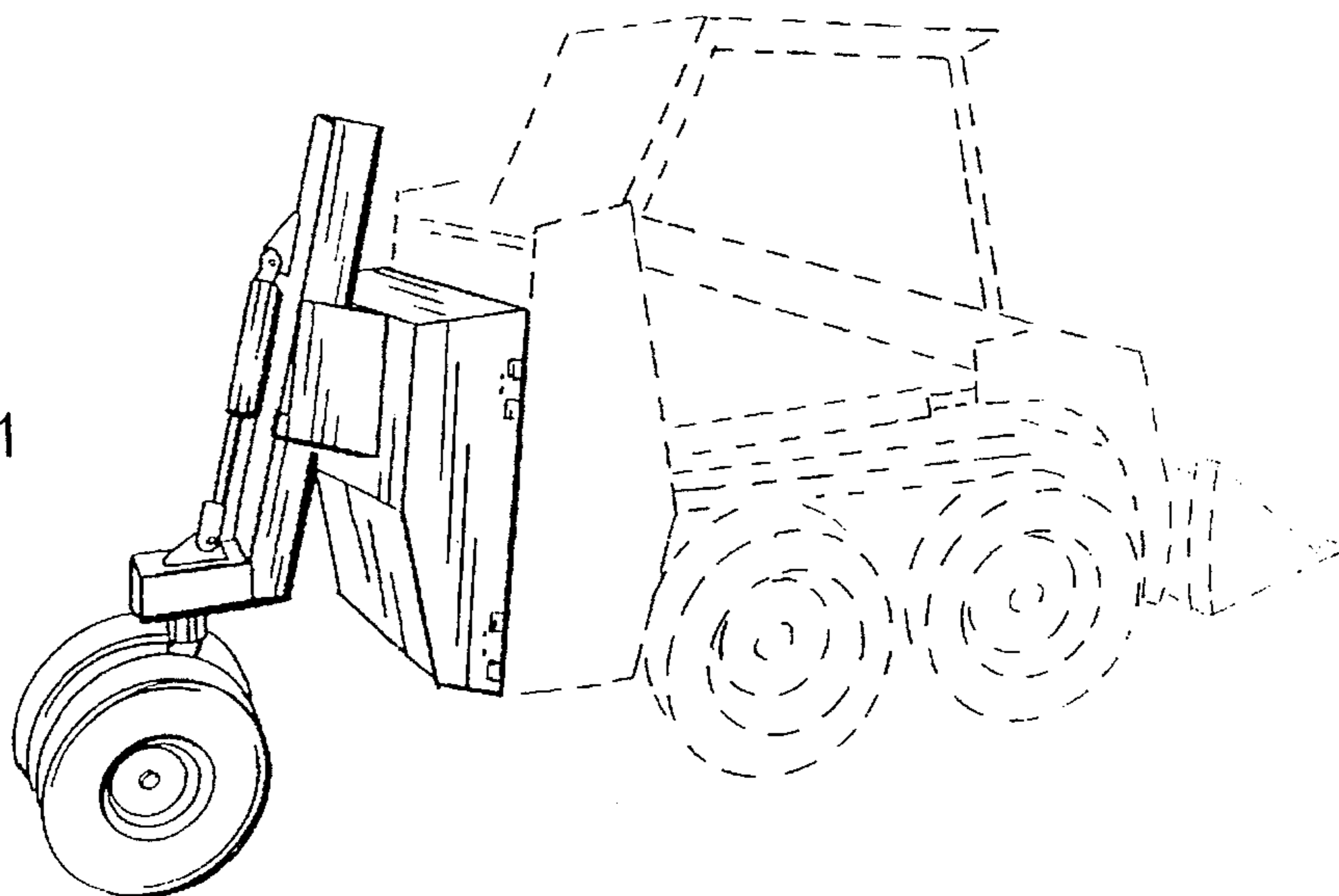

FIG. 2

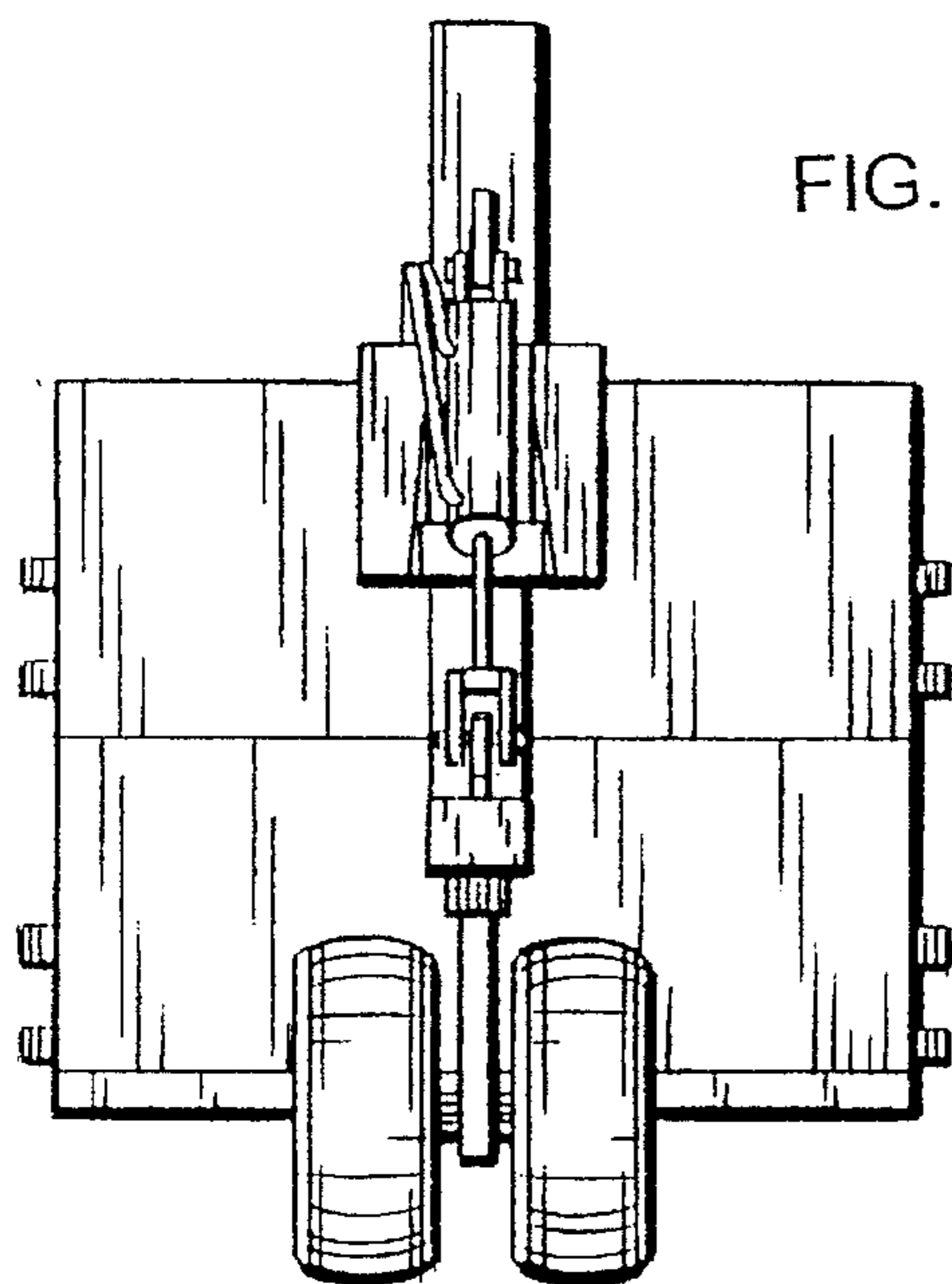
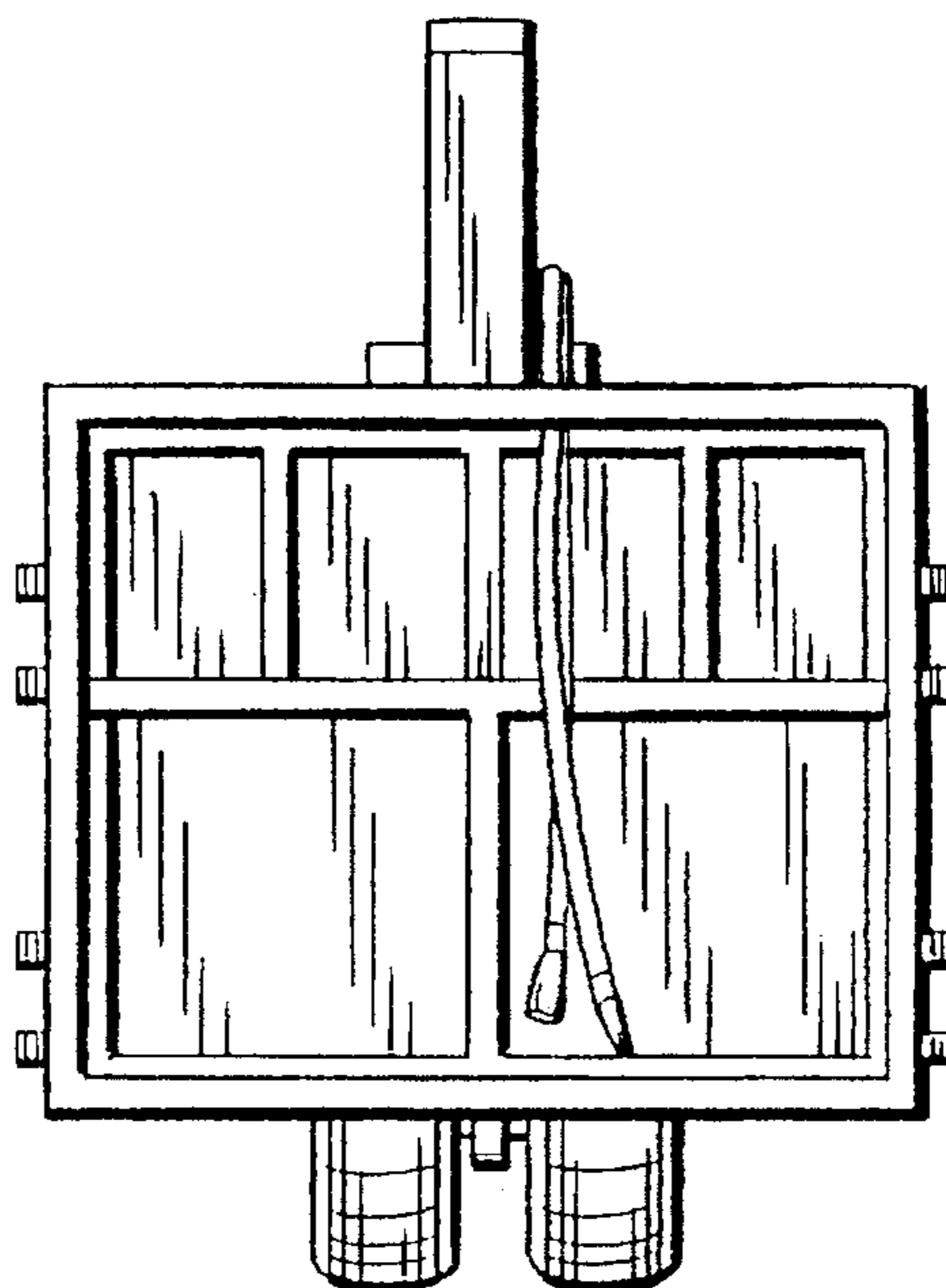

FIG. 3



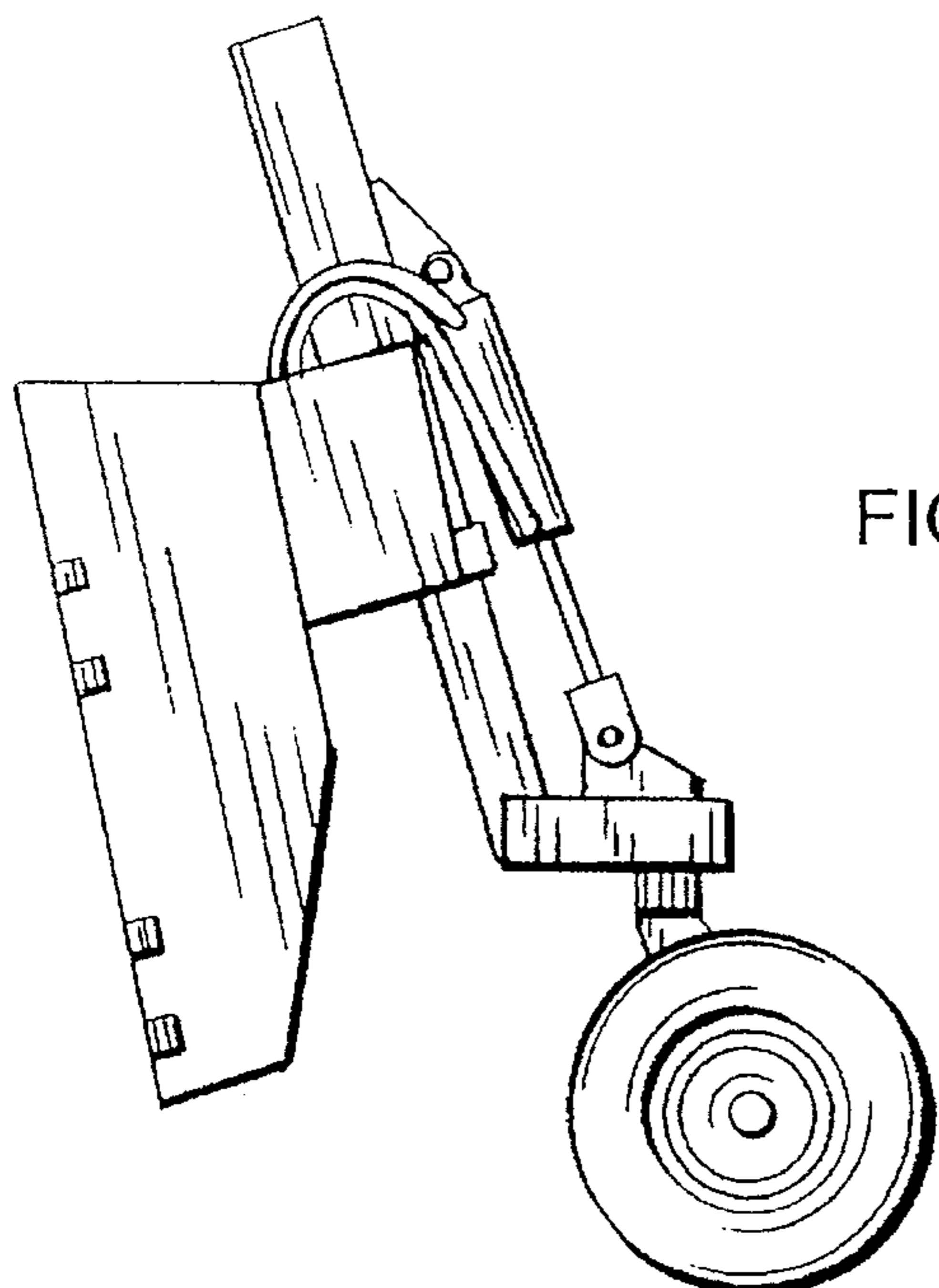

FIG. 4

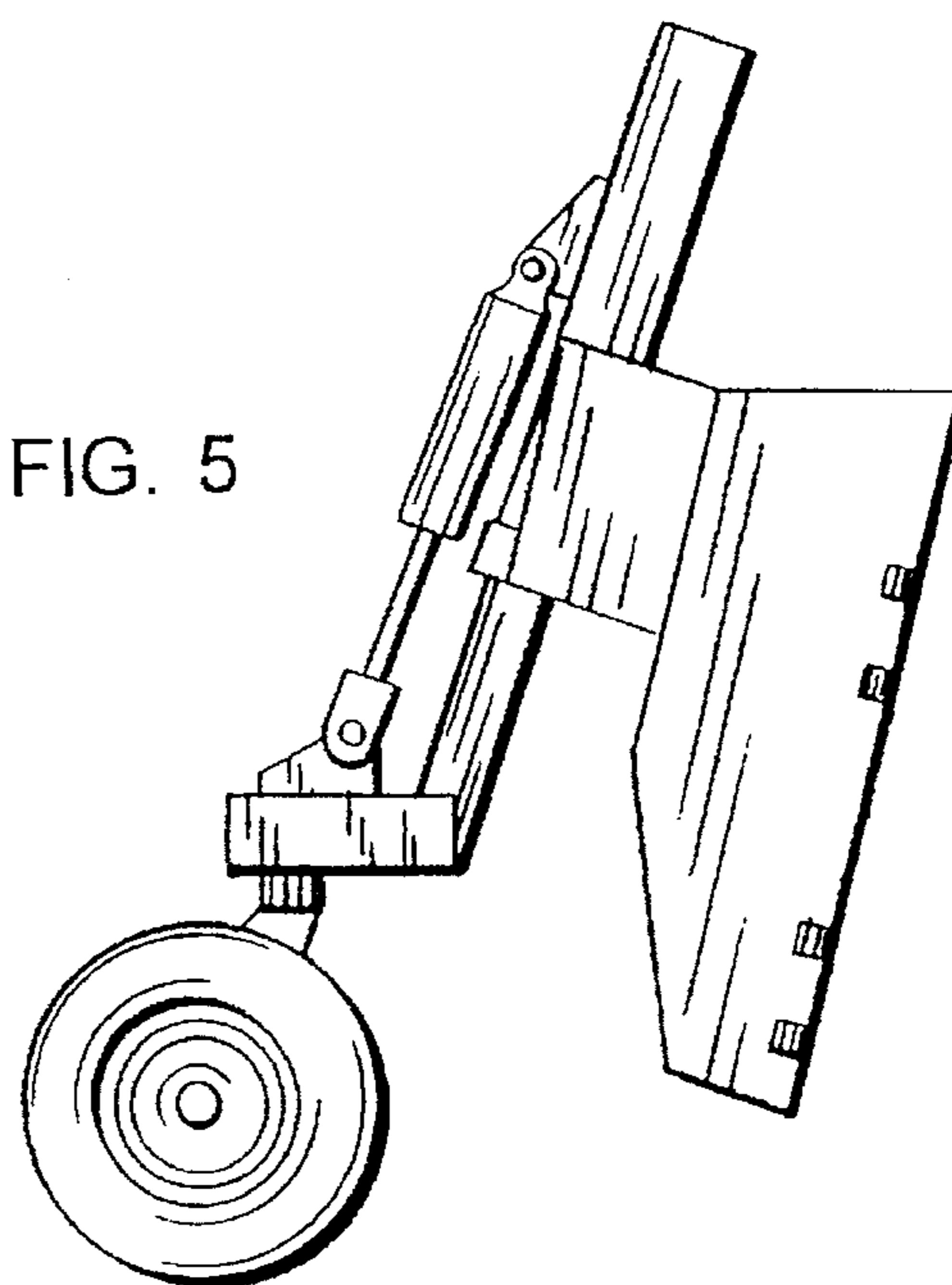

FIG. 5

FIG. 6

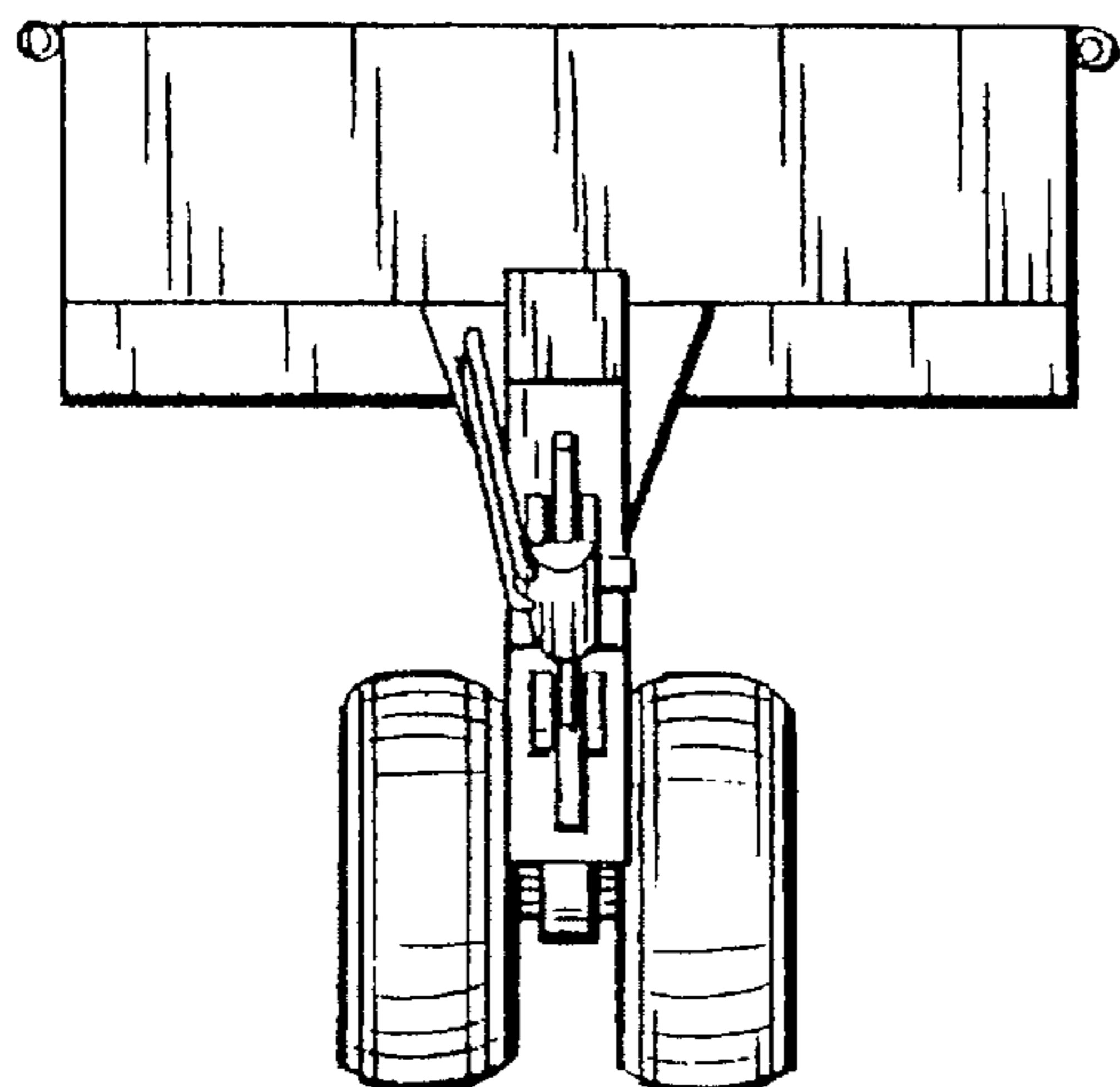

FIG. 7

