



US00D382233S

# United States Patent [19] Stotsky

[11] Patent Number: Des. 382,233

[45] Date of Patent: \*\*Aug. 12, 1997

[54] ONE-PIECE SEAT STAY  
[75] Inventor: Michael Stotsky, Chicago, Ill.  
[73] Assignee: Santa's Best, Northfield, Ill.  
[\*\*] Term: 14 Years

2,444,876 7/1948 Kuhl ..... 280/495  
4,856,801 8/1989 Hollingsworth ..... 280/284  
5,129,665 7/1992 Suffer et al. .... 280/274

Primary Examiner—Melody N. Brown  
Attorney, Agent, or Firm—Emrich & Dithmar

[21] Appl. No.: 50,259  
[22] Filed: Feb. 13, 1996

[57] CLAIM  
The ornamental design for a one-piece seat stay, as shown and described.

[51] LOC (6) Cl. .... 12-11  
[52] U.S. Cl. .... D12/117  
[58] Field of Search ..... D12/117, 111;  
D8/370; 280/281.1, 284, 288; 24/26-27,  
29; 248/300, 316

### DESCRIPTION

FIG. 1 is a right side elevation view of a one-piece seat stay showing my new design, it being understood that the portion of the bicycle shown in broken lines are for illustrative purposes only and form no part of the claimed design; FIG. 2 is a perspective view of the seat stay; FIG. 3 is a top plan view of the seat stay; FIG. 4 is a right side elevational view of the seat stay, the left side being identical to the right side view; FIG. 5 is a rear elevational view thereof; and, FIG. 6 is a front elevational view thereof.

[56] References Cited  
U.S. PATENT DOCUMENTS

D. 370,647 6/1996 Levin et al. .... D12/117  
600,329 3/1898 Burnahm ..... 280/288  
640,113 12/1899 Dixon ..... 280/284  
1,278,122 9/1918 Duffy ..... 280/284  
2,353,712 7/1944 Dewey ..... 280/281.1

1 Claim, 1 Drawing Sheet

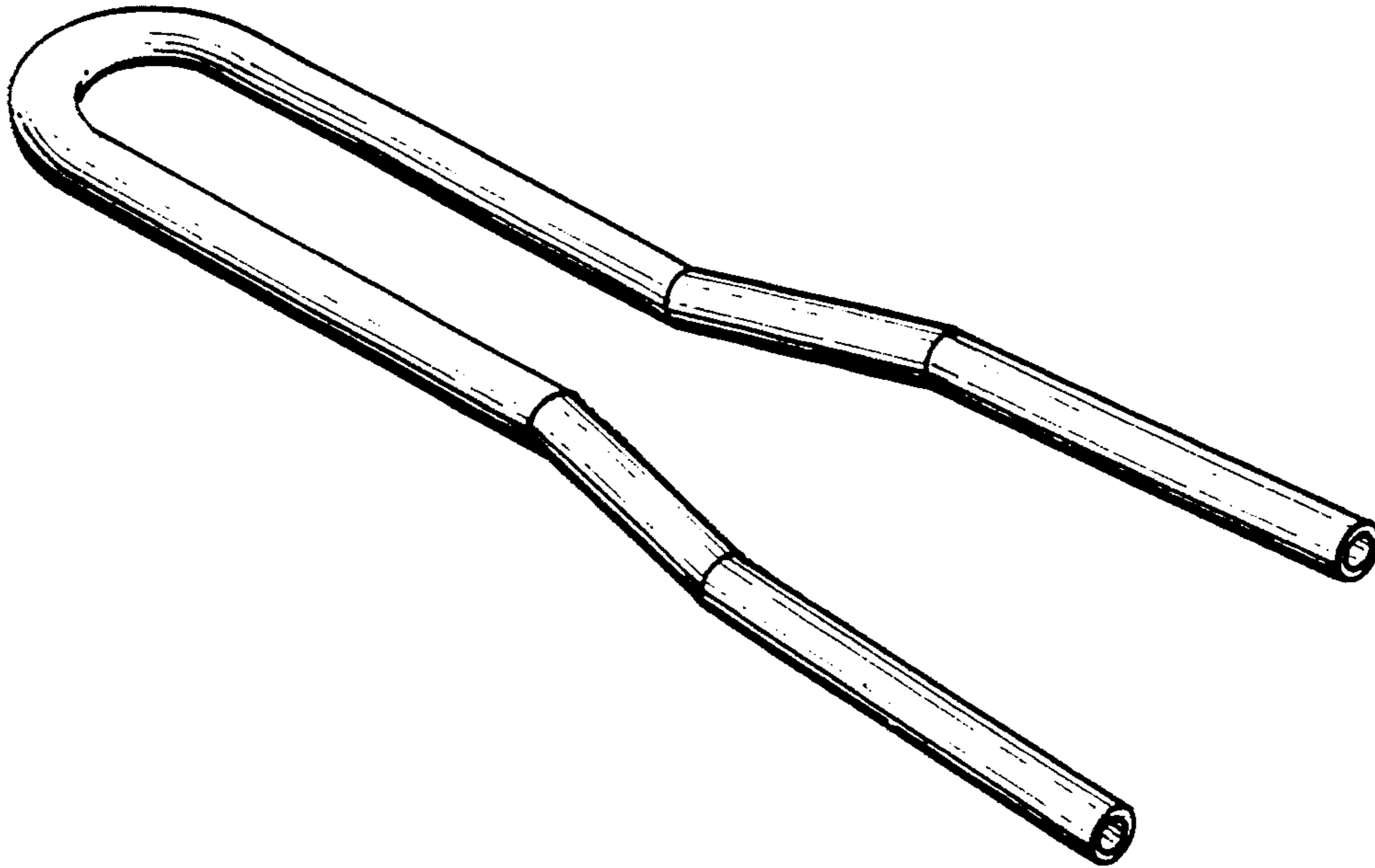

FIG. 1

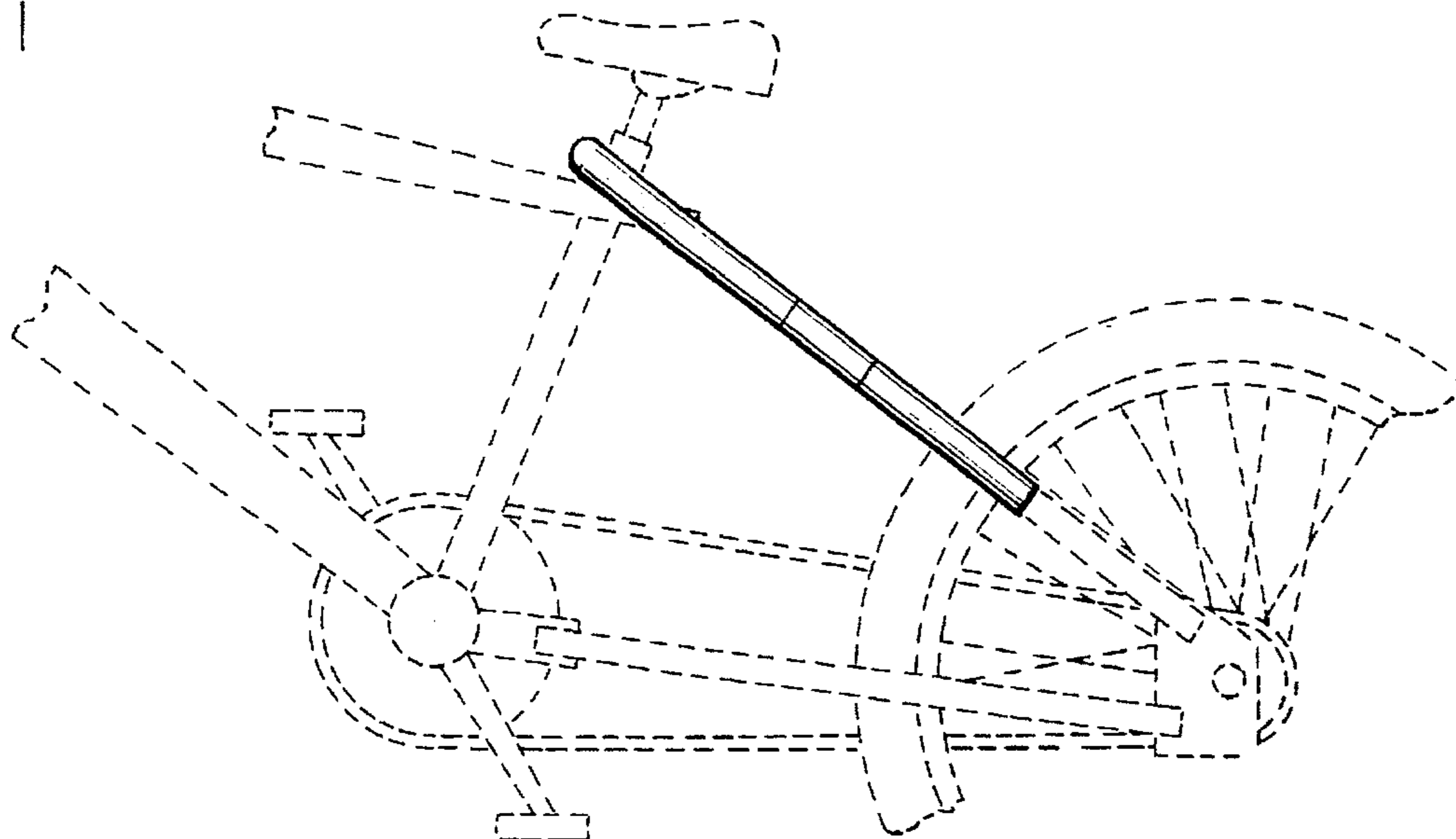

FIG. 2

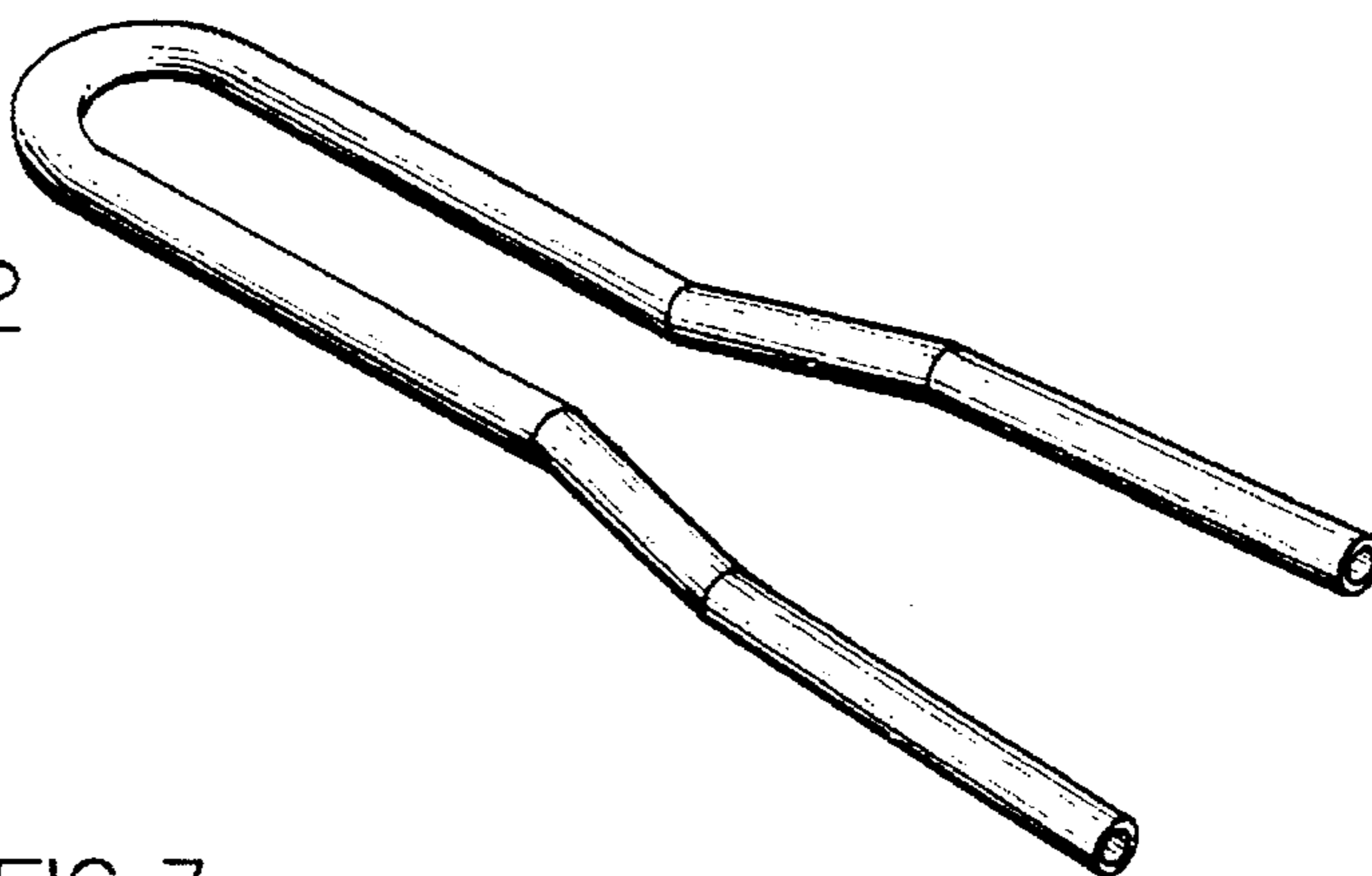

FIG. 3

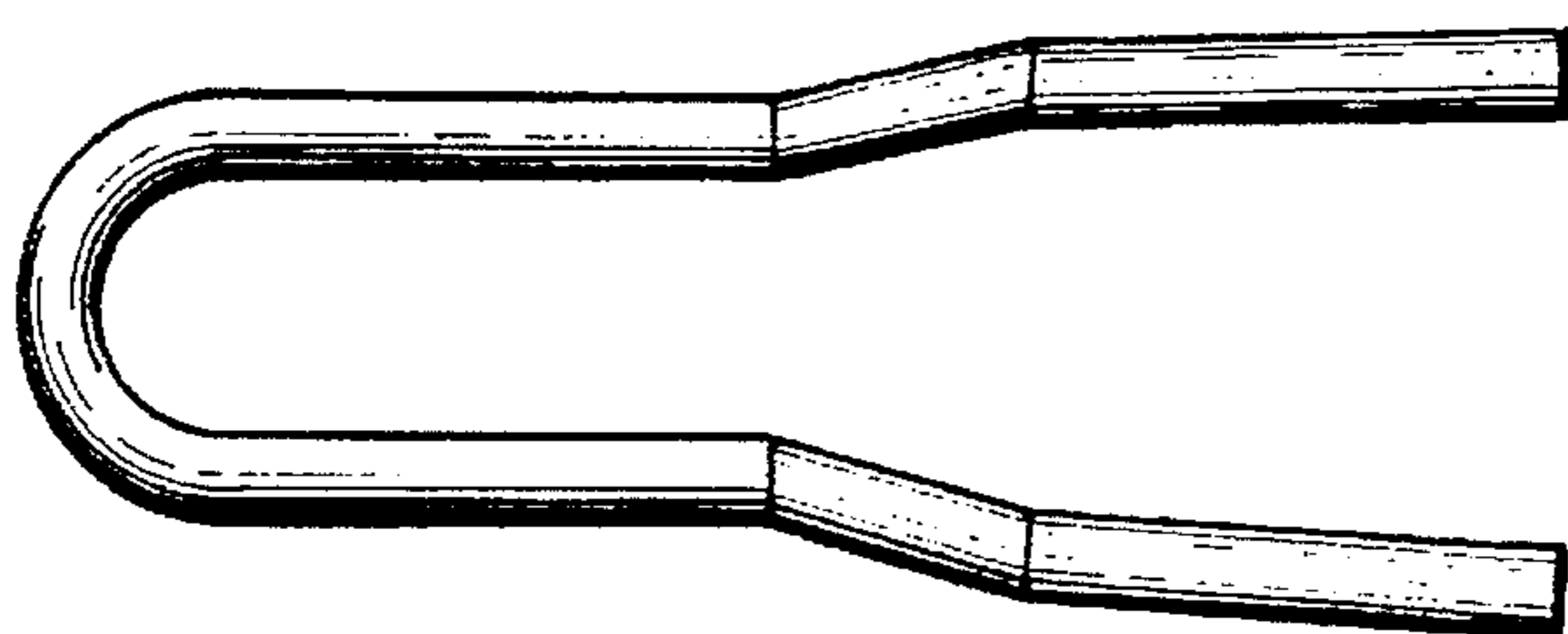

FIG. 4



FIG. 5

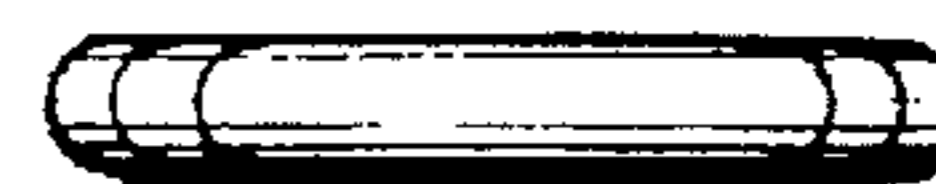

FIG. 6

