



US00D382027S

United States Patent [19]

Petersson et al.

[11] Patent Number: **Des. 382,027**

[45] Date of Patent: ****Aug. 5, 1997**

[54] **RAIL ELEMENT FOR A TOY RAILWAY**

[75] Inventors: **Ingvar Petersson**, Killeberg; **Börje Sander**, Lönsboda; **Kjell Bertilsson**, Osby, all of Sweden

[73] Assignee: **Brio AB**, Osby, Sweden

[**] Term: **14 Years**

[21] Appl. No.: **56,725**

[22] Filed: **Jul. 8, 1996**

[30] **Foreign Application Priority Data**

Jan. 23, 1996 [SE] Sweden 95-0147

[51] **LOC (6) Cl.** **21-01**

[52] **U.S. Cl.** **D21/143**

[58] **Field of Search** D21/129, 143; 446/410, 444-447, 467, 470, 476, 424, 168; 238/10 B, 10 F, 10 R; 104/DIG. 1; 105/1.5

[56] **References Cited**

U.S. PATENT DOCUMENTS

D. 195,679 7/1963 Genin et al. D21/143

D. 287,609 1/1987 Petersson D21/143
D. 326,880 6/1992 Larsen D21/143
3,379,440 4/1968 Jaffe 446/168

OTHER PUBLICATIONS

Brio Wooden Railway Catalog 1993, p. 14, Element 'L' and 'M'.

Lionel Catalog 1968, p. 32, top left of page.

Primary Examiner—Raphael Barkai
Attorney, Agent, or Firm—Barnes, Kisselle, Raisch, Choate, Whittemore & Hulbert, P.C.

[57] **CLAIM**

The ornamental design for a rail element for a toy railway, as shown.

DESCRIPTION

FIG. 1 is a top perspective view of a rail element for a toy railway showing our new design;
FIG. 2 is a bottom perspective view thereof;
FIG. 3 is a top perspective view of a modified embodiment of the design shown in FIGS. 1 and 2; and,
FIG. 4 is a bottom perspective view thereof.

1 Claim, 2 Drawing Sheets

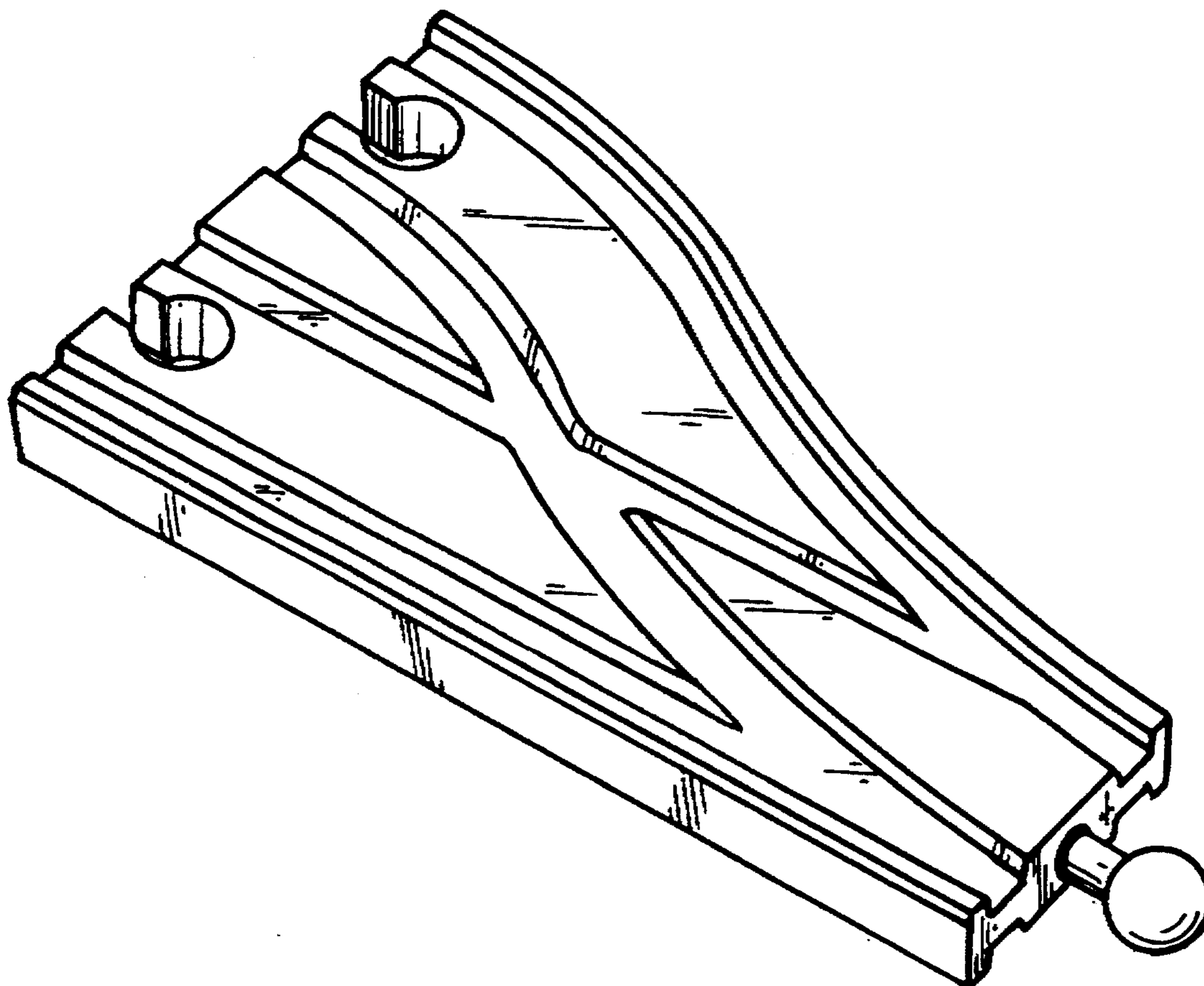

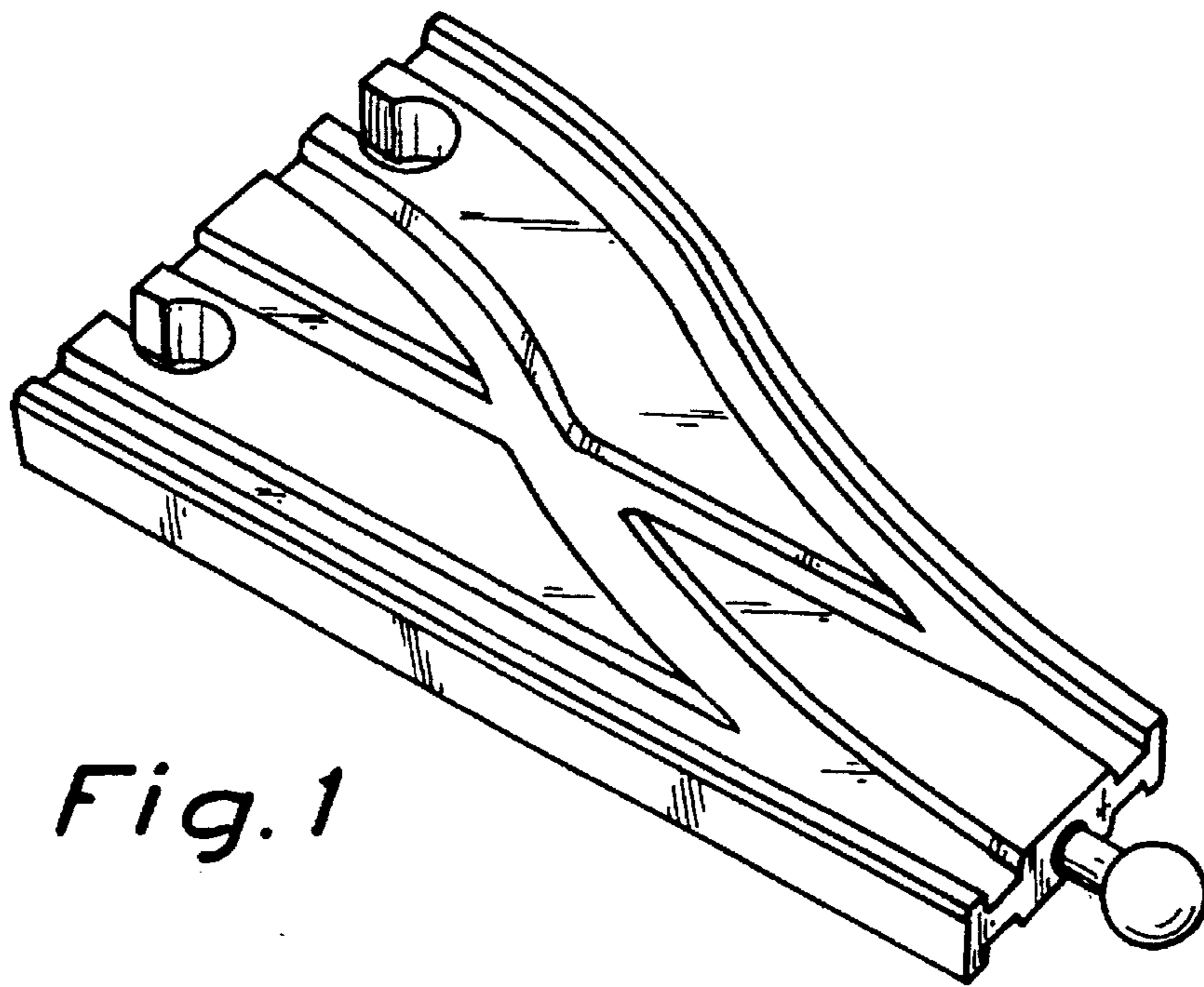

Fig. 1

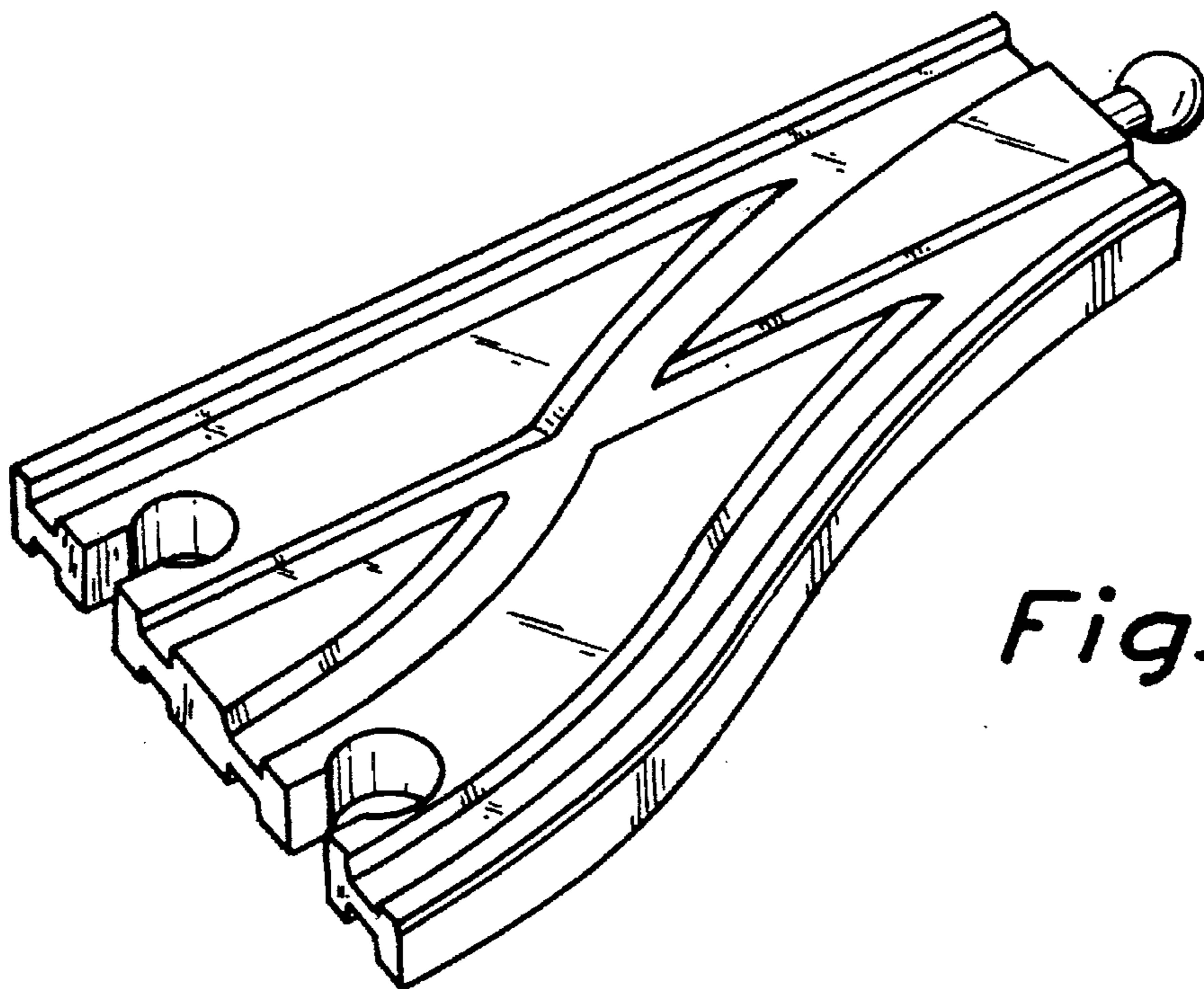

Fig. 2

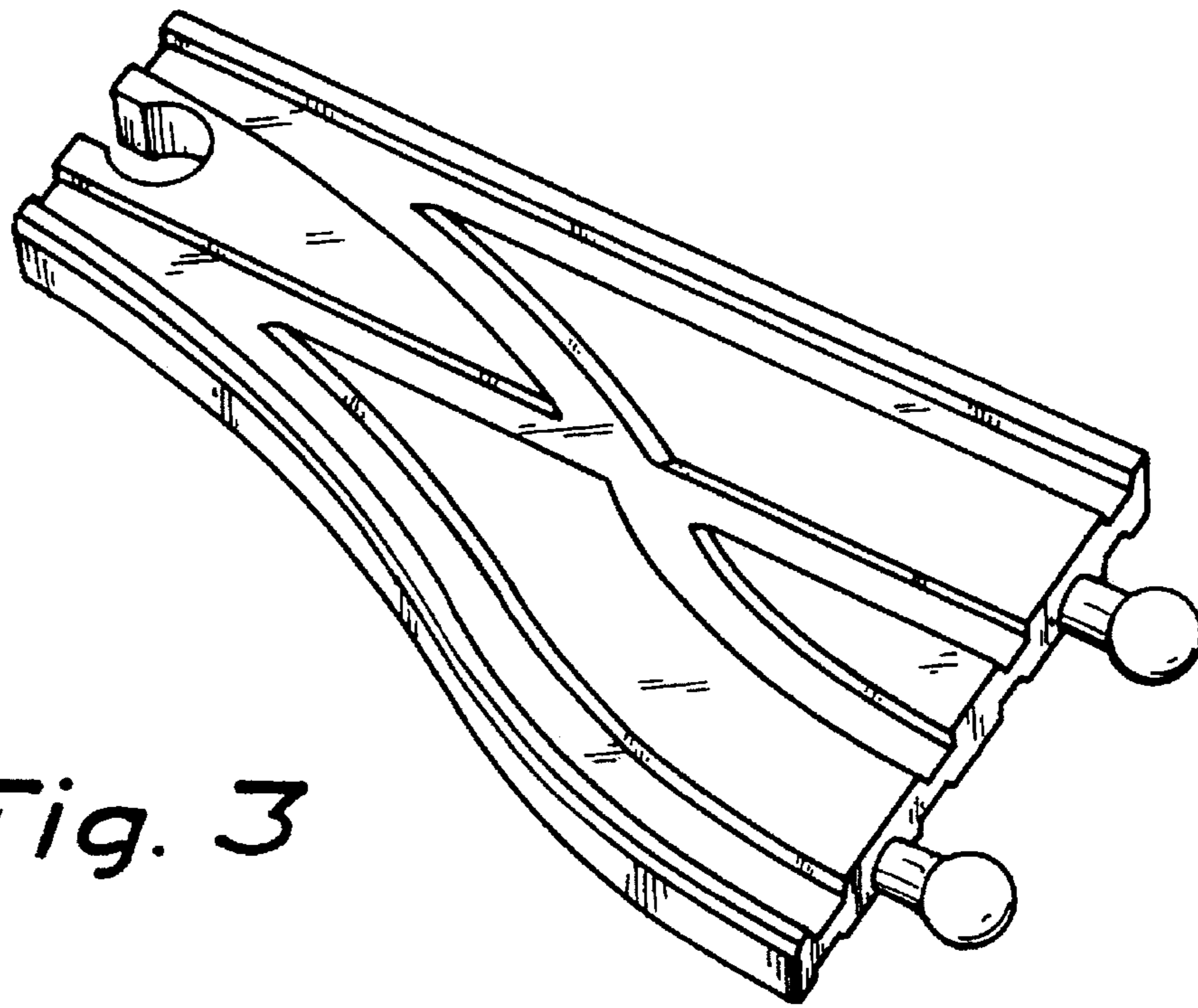

Fig. 3

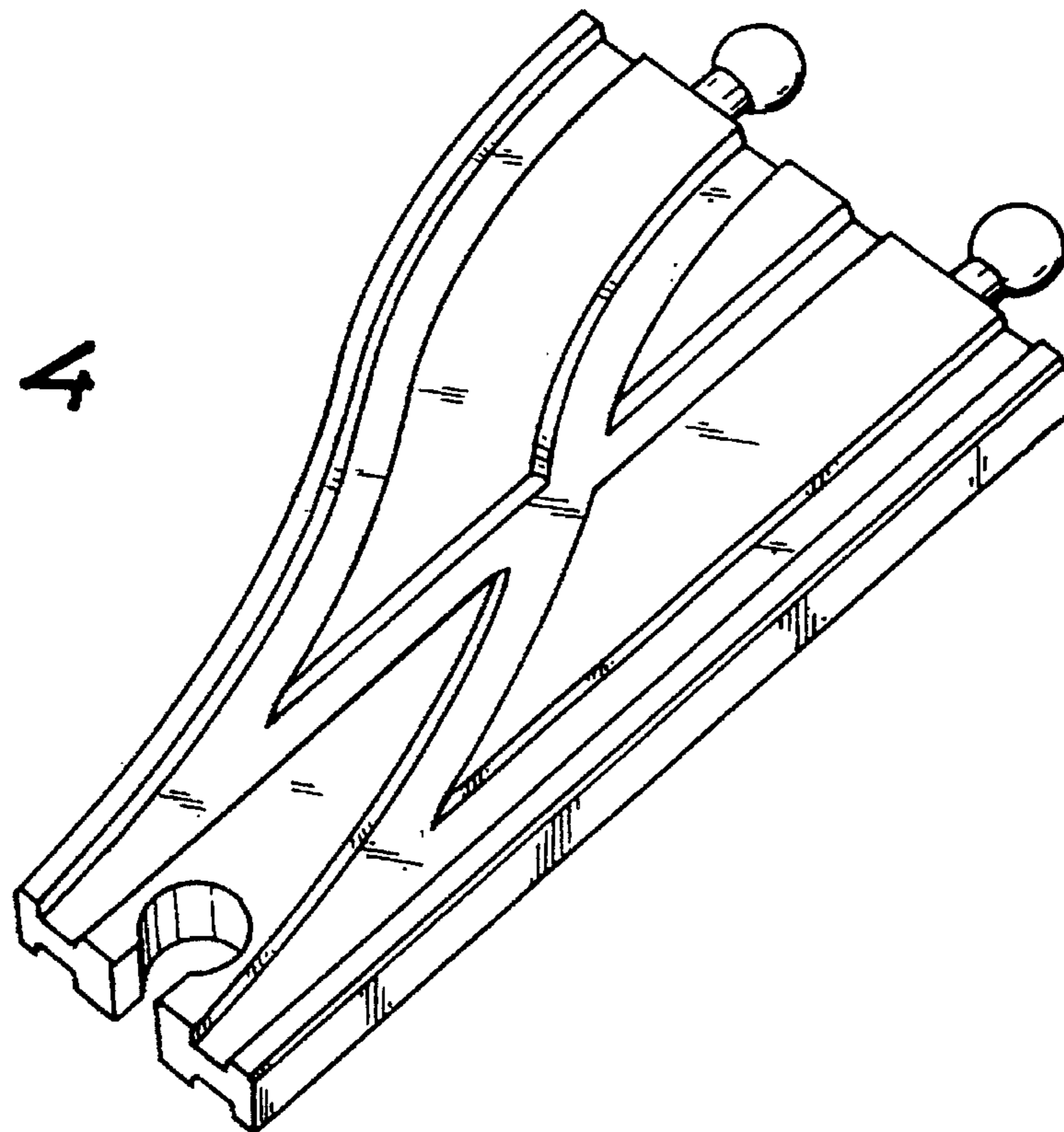

Fig. 4