



US00D381953S

United States Patent [19]

Collins et al.

[11] Patent Number: **Des. 381,953**

[45] Date of Patent: ****Aug. 5, 1997**

[54] **TOP FOR EMERGENCY VEHICLE**

[75] Inventors: **Donald L. Collins**, Winter Park; **Scott M. Morton**, Orlando; **Herschel W. Davis**, Altamonte Springs, all of Fla.

[73] Assignee: **Wheeled Coach Industries, Inc.**, Winter Park, Fla.

[**] Term: **14 Years**

[21] Appl. No.: **46,703**

[22] Filed: **Oct. 26, 1995**

[51] LOC (6) Cl. **12-16**

[52] U.S. Cl. **D12/401**

[58] Field of Search D12/400, 401, D12/404, 99; 296/99.1, 100, 102, 156, 164, 210, 211, 213, 214, 19; D21/128, 133

[56] **References Cited**

U.S. PATENT DOCUMENTS

- D. 230,143 1/1974 Cox D12/99
- D. 262,533 1/1982 Hanson D12/401
- D. 310,649 9/1990 Lee D12/404
- D. 362,423 9/1995 Thomas, Jr. D12/401

- 4,837,914 6/1989 Borum et al. 296/210 X
- 5,029,936 7/1991 Gonzalez D12/401 X
- 5,104,177 4/1992 Thomas, Jr. 296/210

Primary Examiner—Doris V. Coles
Assistant Examiner—Catherine R. Oliver
Attorney, Agent, or Firm—Shook, Hardy & Bacon L.L.P.

[57] **CLAIM**

The ornamental design for a top for emergency vehicle, as shown and described.

DESCRIPTION

FIG. 1 is a side elevation view of a top for emergency vehicle showing our new design;
FIG. 2 is a slightly enlarged top perspective view thereof;
FIG. 3 is a greatly enlarged side elevation view thereof, the other side being a mirror image of the view shown;
FIG. 4 is a greatly enlarged top plan view thereof;
FIG. 5 is a greatly enlarged front elevation view thereof; and,
FIG. 6 is a greatly enlarged rear elevation view thereof.
The broken line showing of a vehicle in FIG. 1 of the drawing is for illustrative purposes only and forms no part of the claimed design.

1 Claim, 2 Drawing Sheets

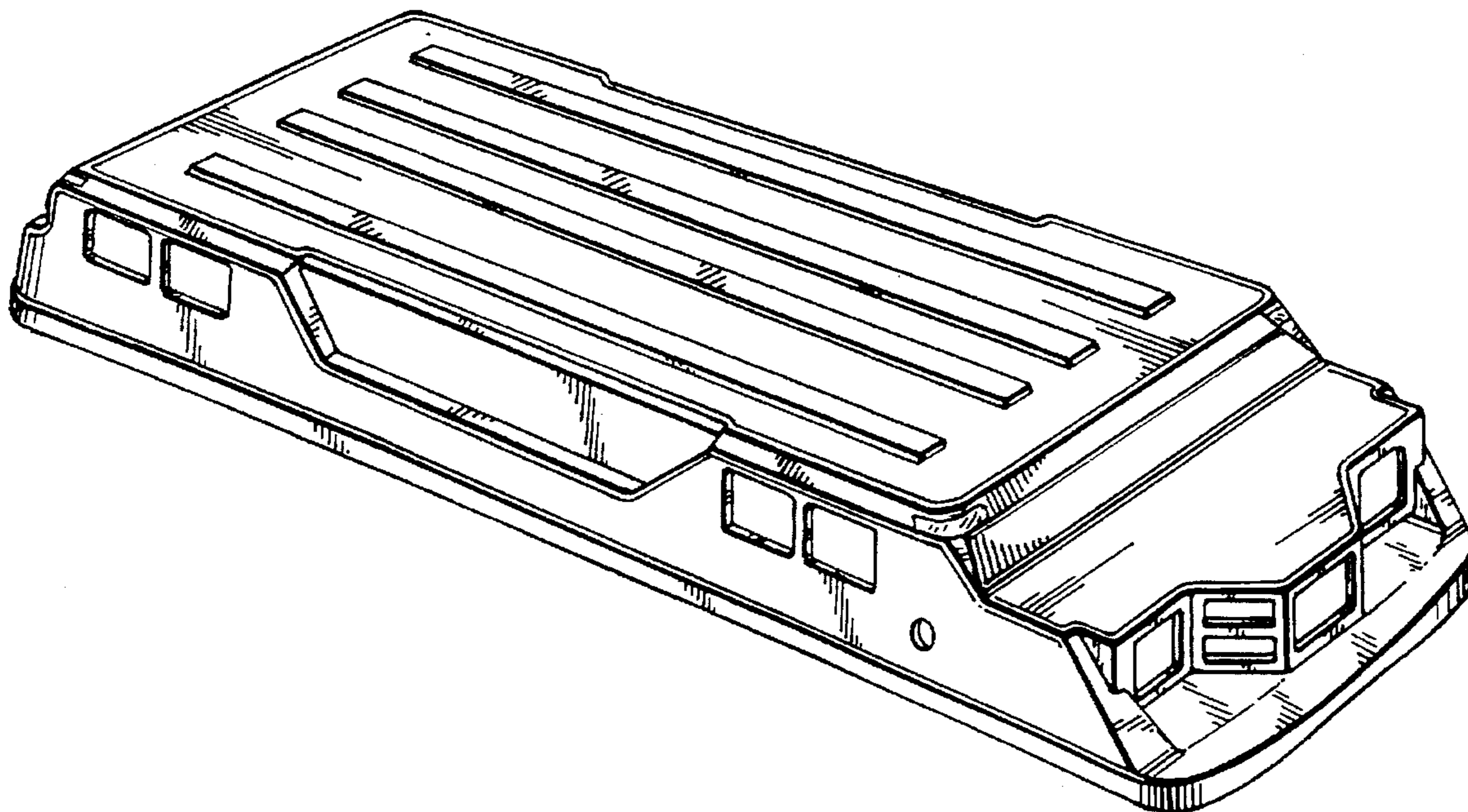

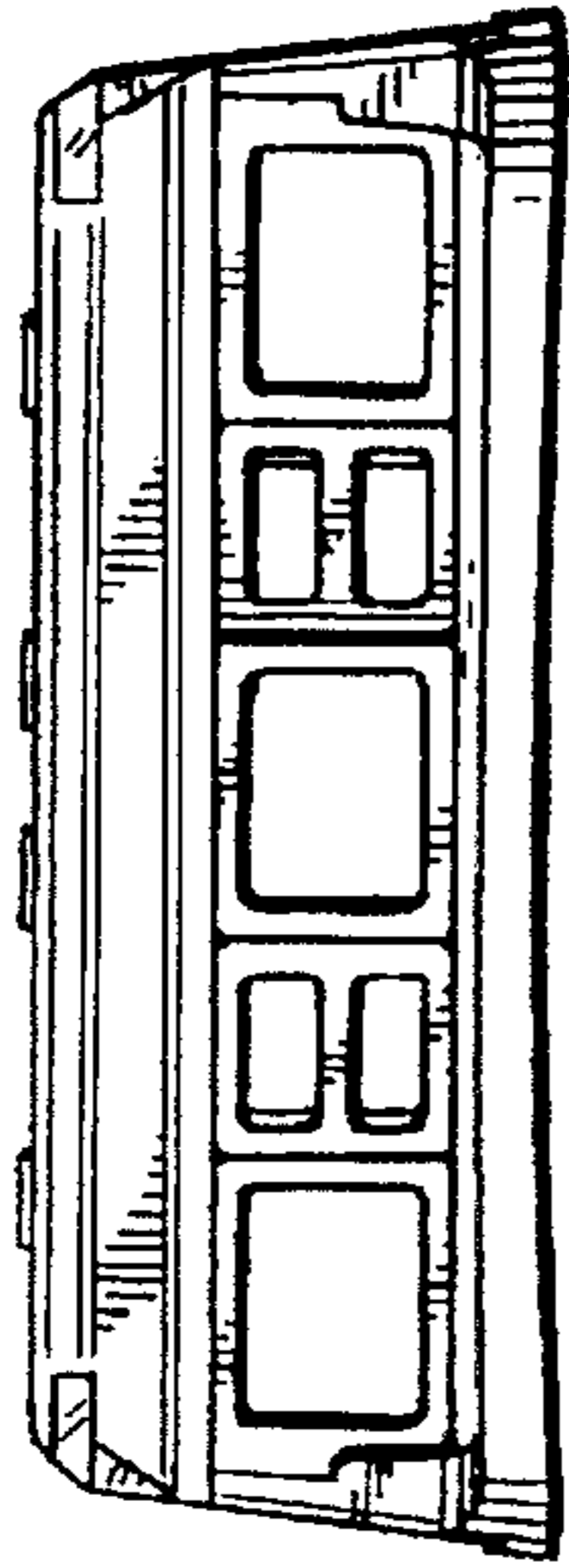
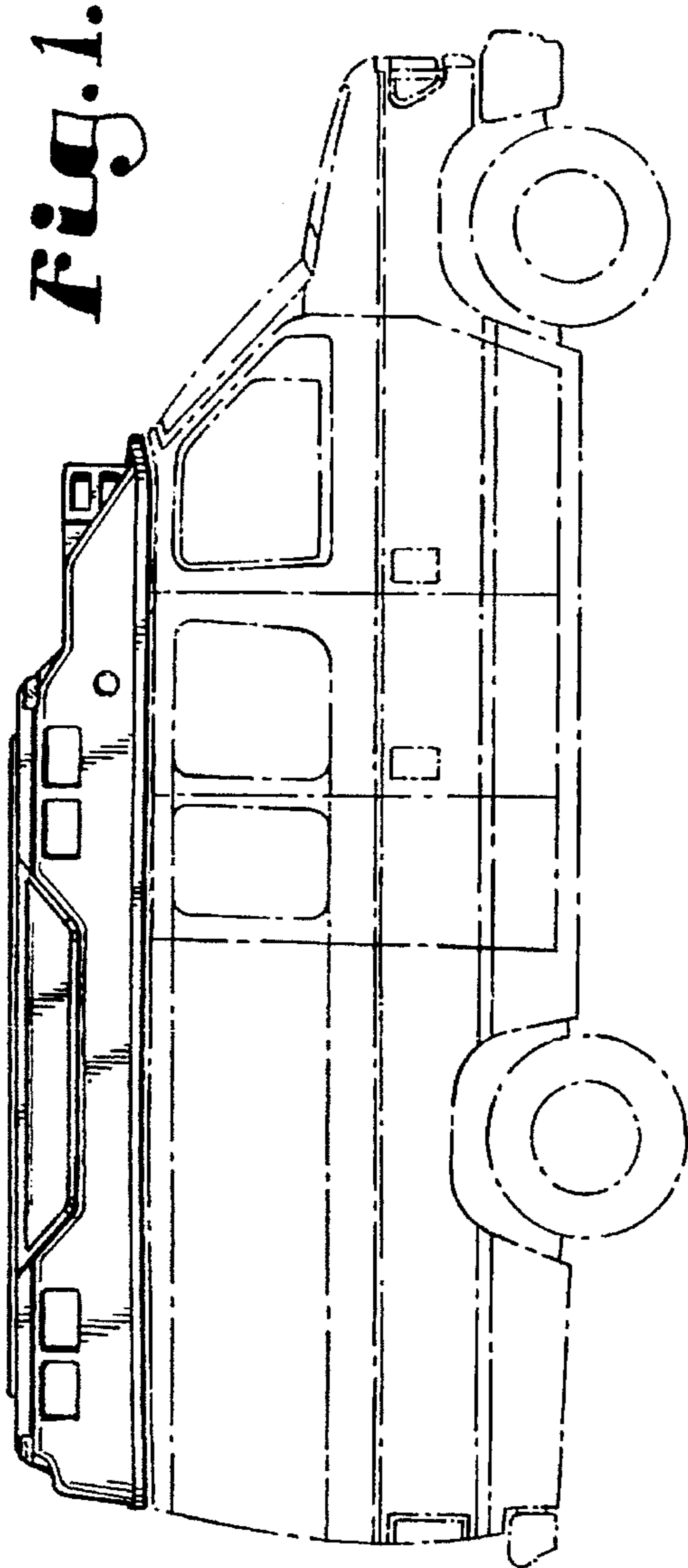

Fig. 5.

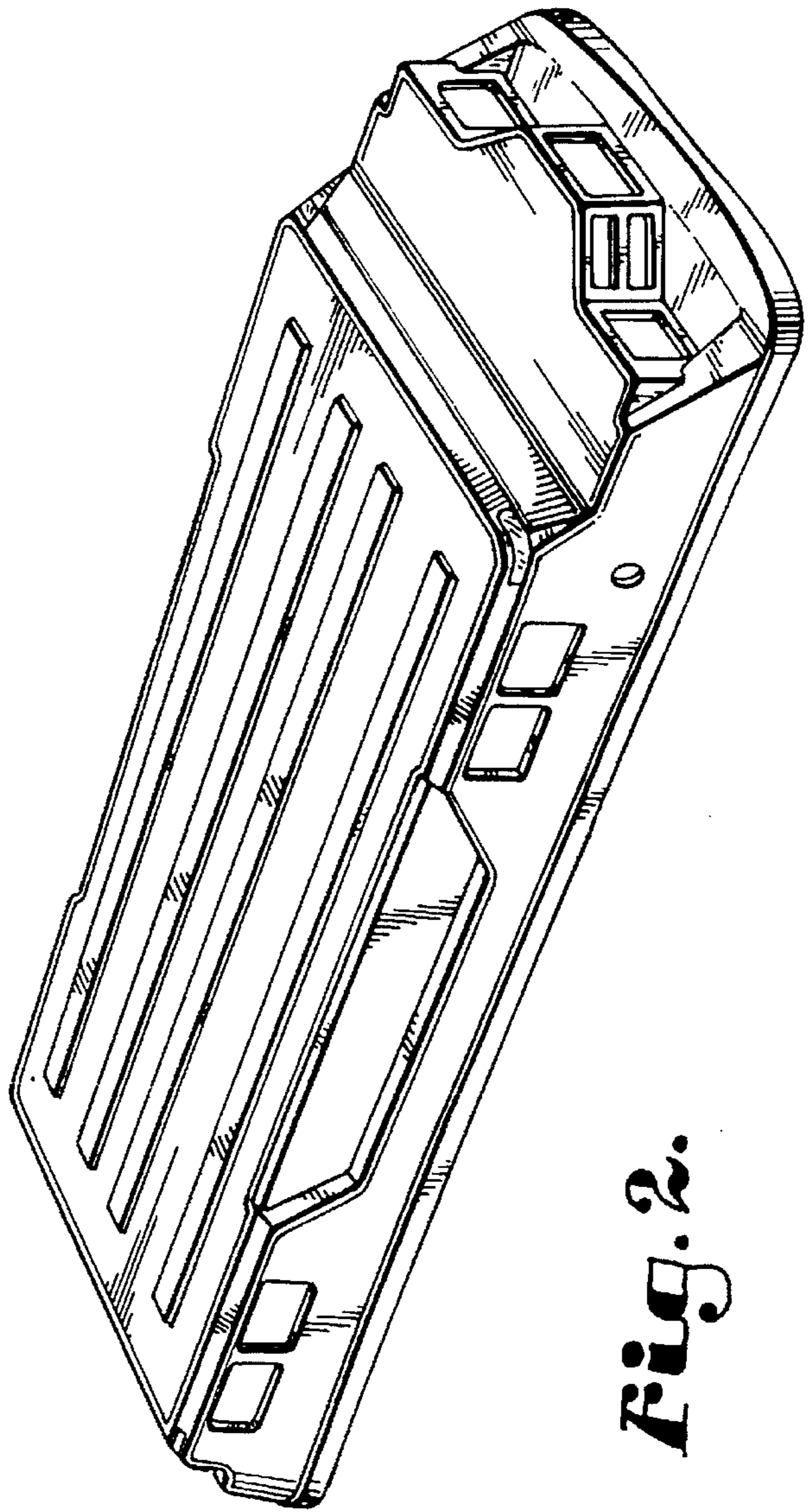

Fig. 2.

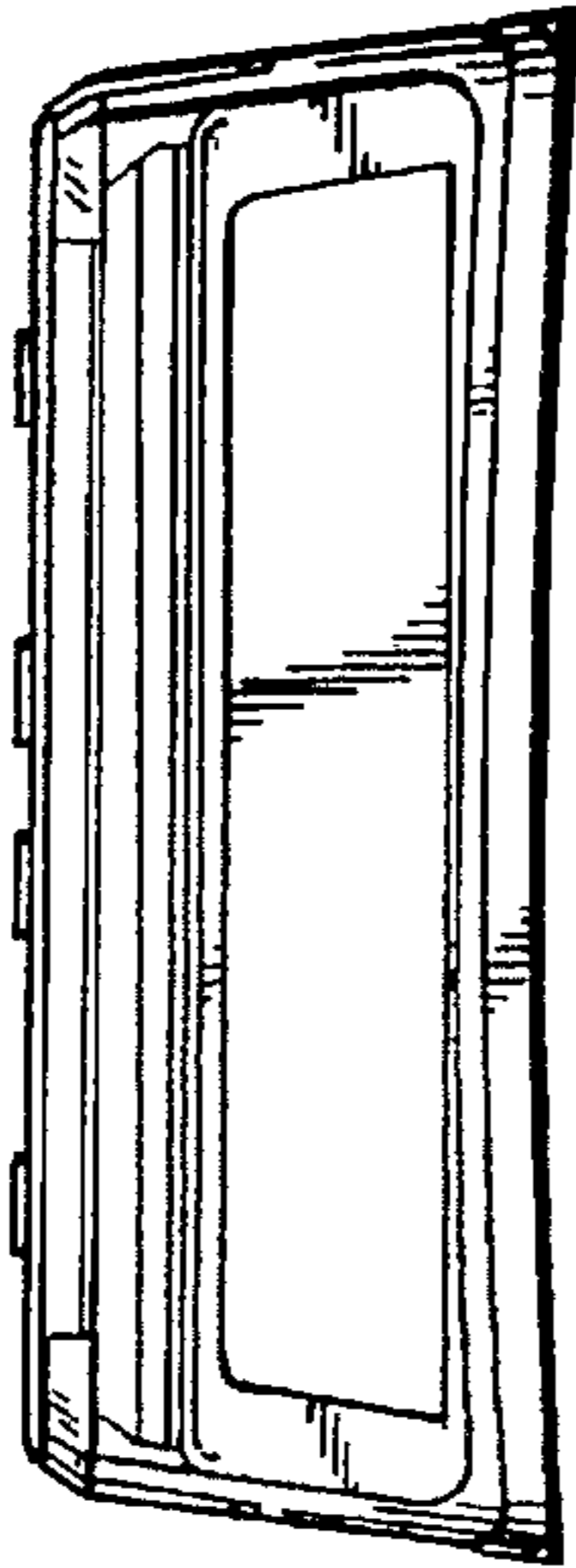

Fig. 6.

Fig. 3.

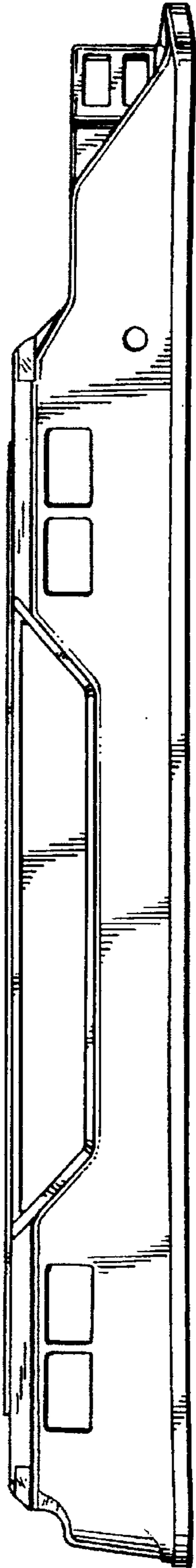

Fig. 4.

