



US00D381919S

United States Patent [19]
Stecher

[11] **Patent Number: Des. 381,919**
[45] **Date of Patent: **Aug. 5, 1997**

[54] **MOTORCYCLE CLOCK**

[75] Inventor: **Peter Stecher**, Verden, Germany

[73] Assignee: **Beate Gottkehaskamp**, Verden, Germany

[**] Term: **14 Years**

[21] Appl. No.: **49,444**

[22] Filed: **Jan. 25, 1996**

[30] **Foreign Application Priority Data**

Jul. 26, 1995 [DE] Germany M 95 05 822.2

[51] **LOC (6) Cl.** **10-01**

[52] **U.S. Cl.** **D10/24; D10/1; D10/2**

[58] **Field of Search** **D10/1-40, 122-132; 368/276-277, 285, 316-317**

[56] **References Cited**

U.S. PATENT DOCUMENTS

D. 287,946	1/1987	Tsuyama	D10/2
D. 288,412	2/1987	Nunes	D10/2
D. 294,228	2/1988	Palazzo	D10/15 X
D. 337,952	8/1993	Wolff	D10/15 X
D. 358,778	5/1995	Davis	D10/15 X
D. 367,533	2/1996	Pinchuk	D10/15 X
4,780,864	10/1988	Houlihan	368/10
4,819,217	4/1989	Houlihan	368/10
4,881,187	11/1989	Read	368/10 X

Primary Examiner—Nelson C. Holtje
Attorney, Agent, or Firm—Collard & Roe, P.C.

[57] **CLAIM**

The ornamental design for a motorcycle clock, as shown and described.

DESCRIPTION

FIG. 1 is a perspective view of a motorcycle clock mounted on a handlebar, showing my new design;
 FIG. 2 is an exploded perspective view thereof;
 FIG. 3 is a front side elevational view thereof;
 FIG. 4 is a rear side elevational view thereof;
 FIG. 5 is a left side elevational view thereof;
 FIG. 6 is a bottom plan view thereof;
 FIG. 7 is a top plan view thereof;
 FIG. 8 is right side elevational view thereof;
 FIG. 9 is a perspective view of a motorcycle clock showing a second embodiment of my new design;
 FIG. 10 is an exploded perspective view thereof;
 FIG. 11 is a front side elevational view thereof;
 FIG. 12 is a rear side elevational view thereof;
 FIG. 13 is a right side elevational view thereof;
 FIG. 14 is a top plan view thereof;
 FIG. 15 is a bottom plan view thereof; and,
 FIG. 16 is a left side elevational view thereof.

The broken line showing of the handlebar in FIG. 1 is included for the purpose of illustrating environmental structure only, and forms no part of the claimed design.

1 Claim, 8 Drawing Sheets

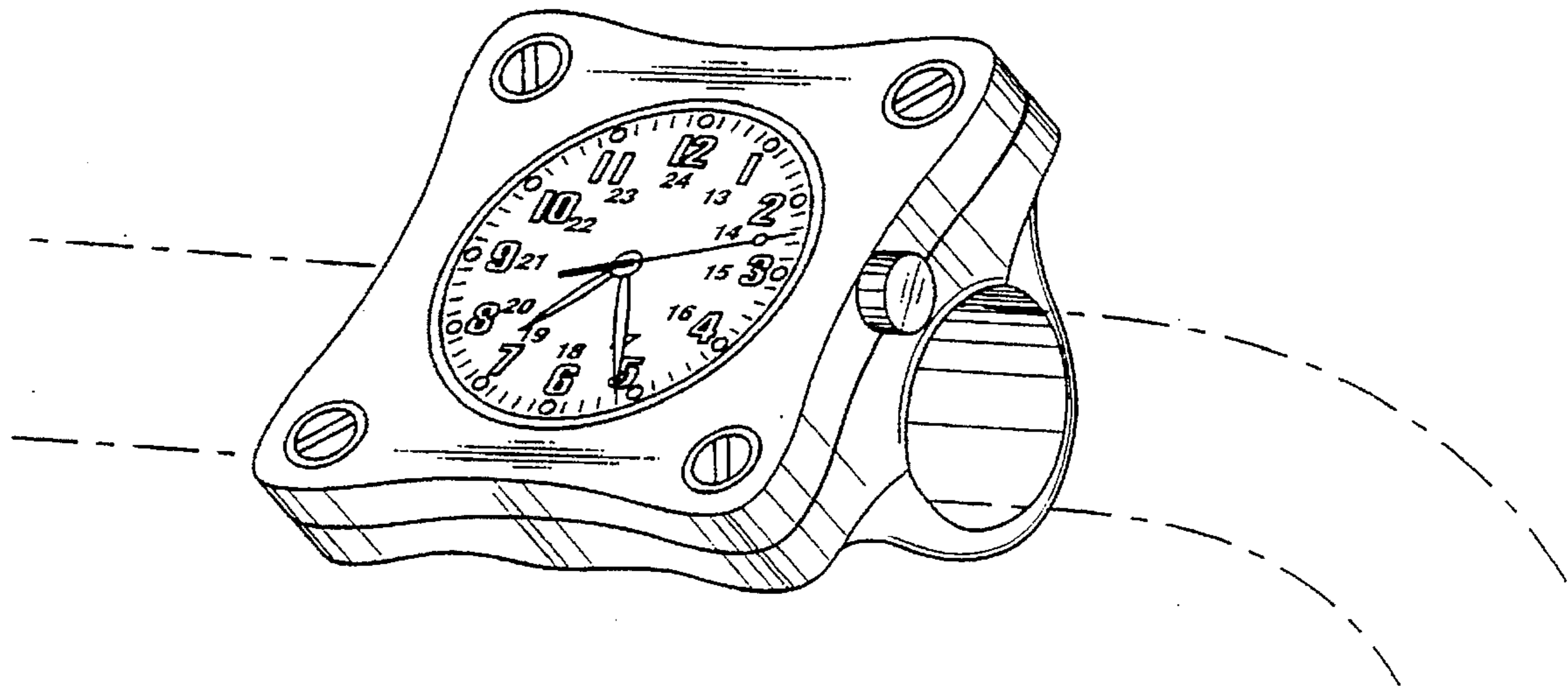

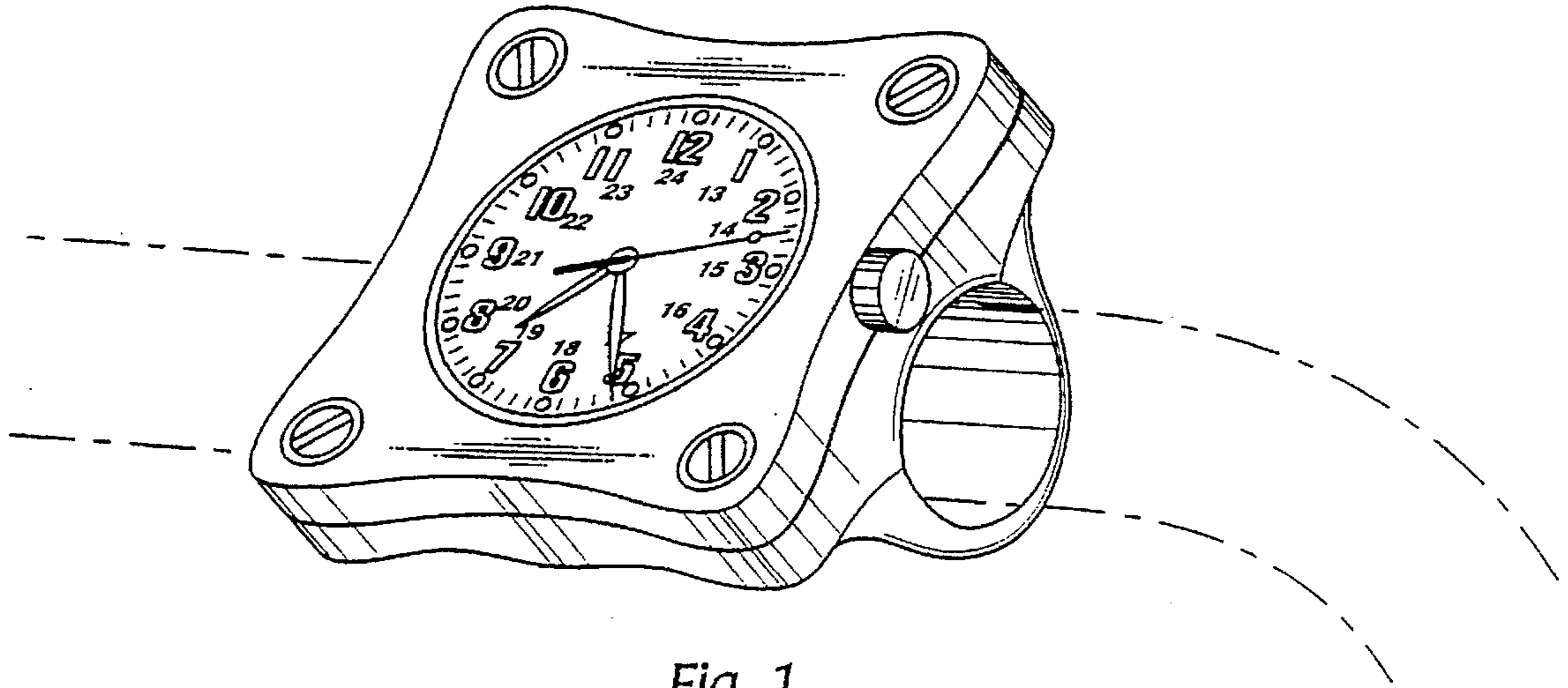

Fig. 1

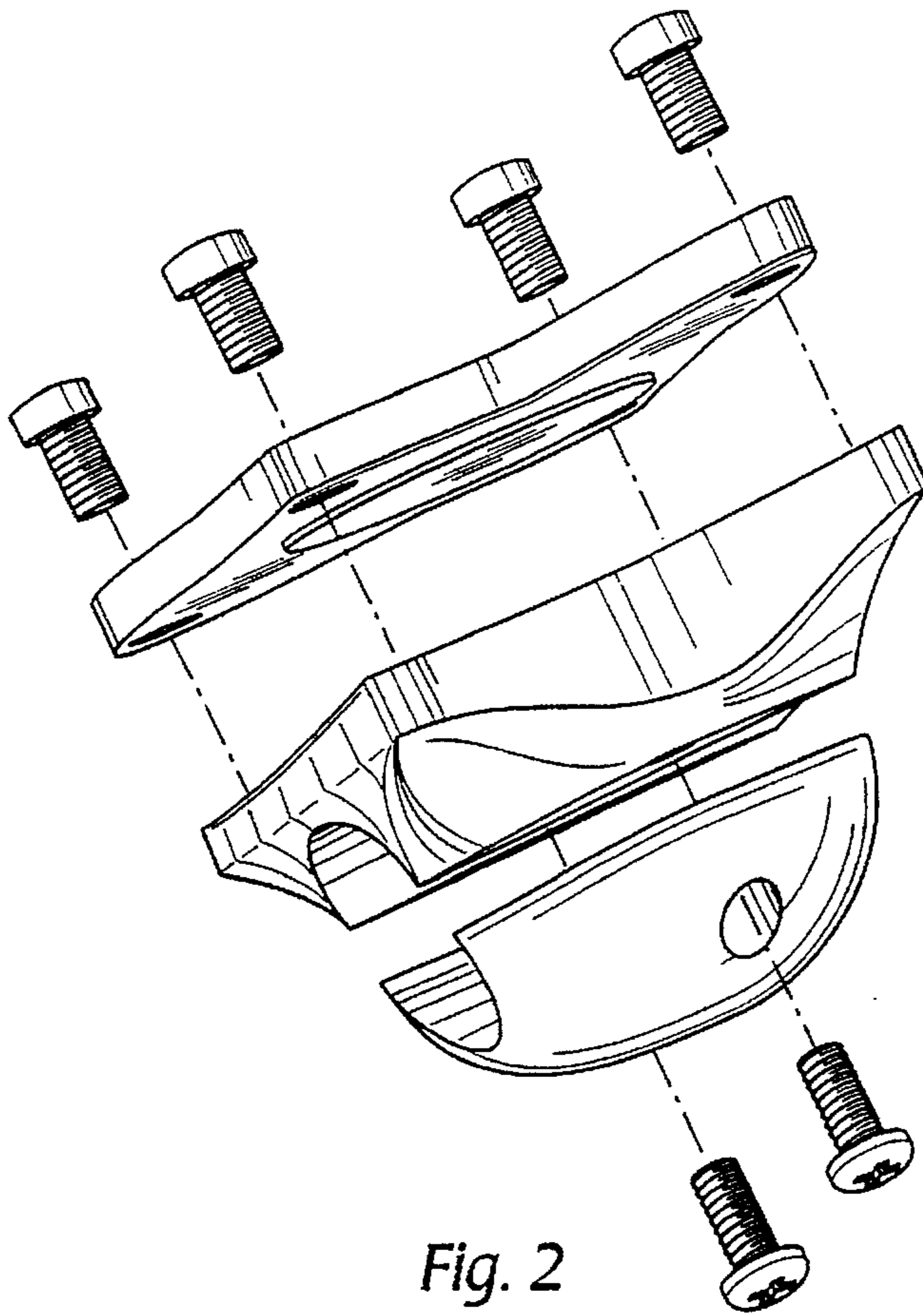

Fig. 2

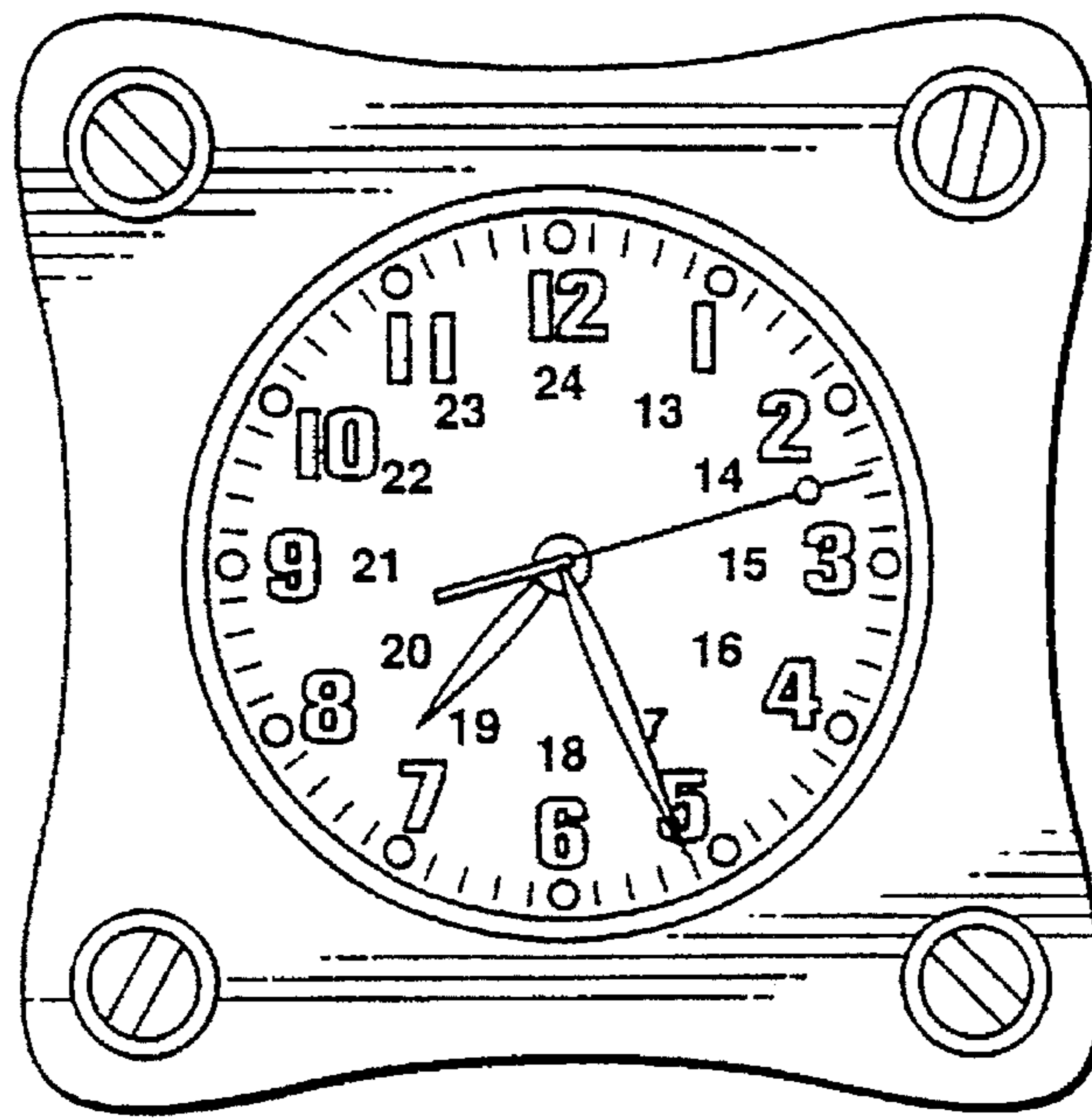

Fig. 3

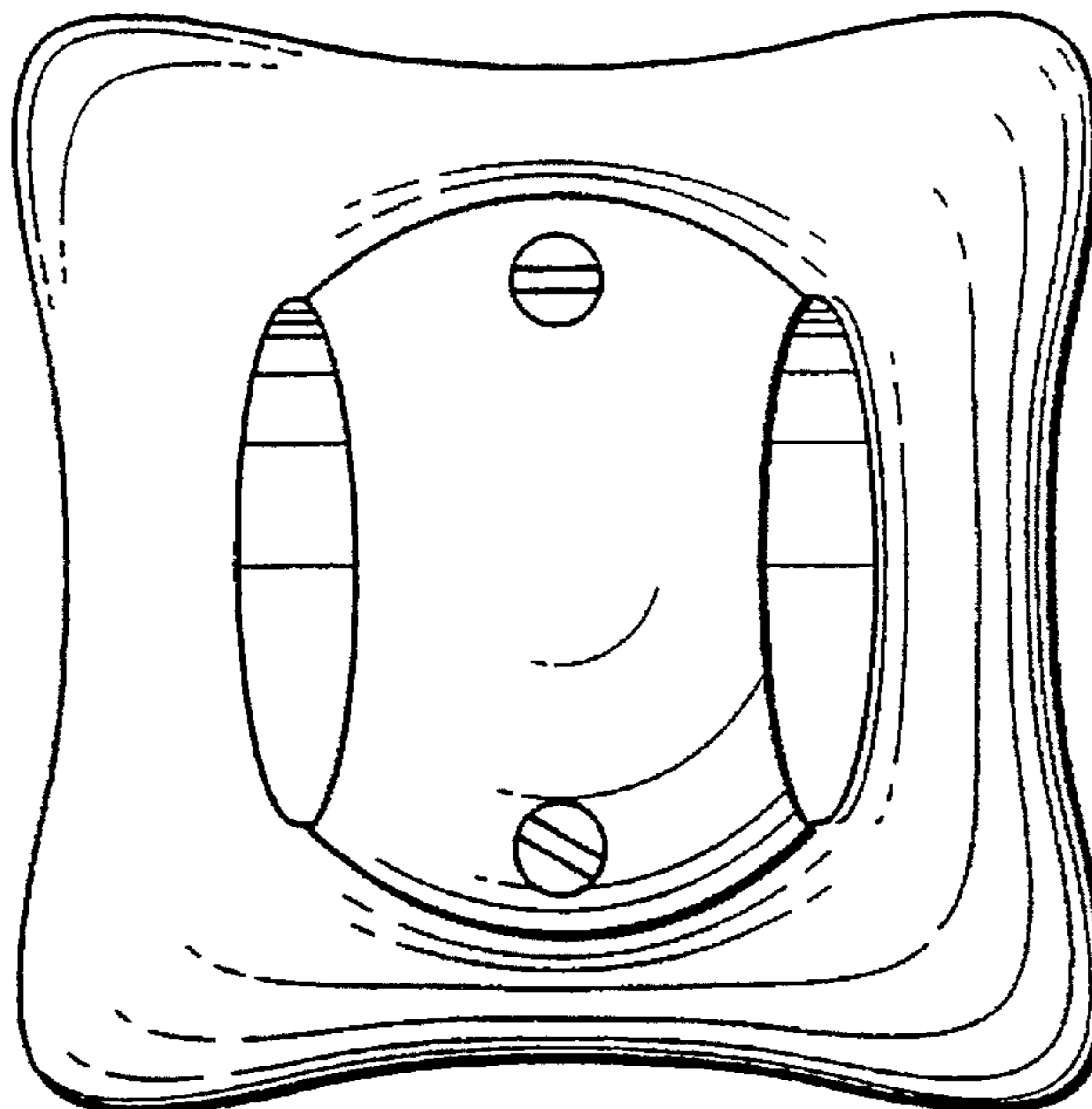

Fig. 4

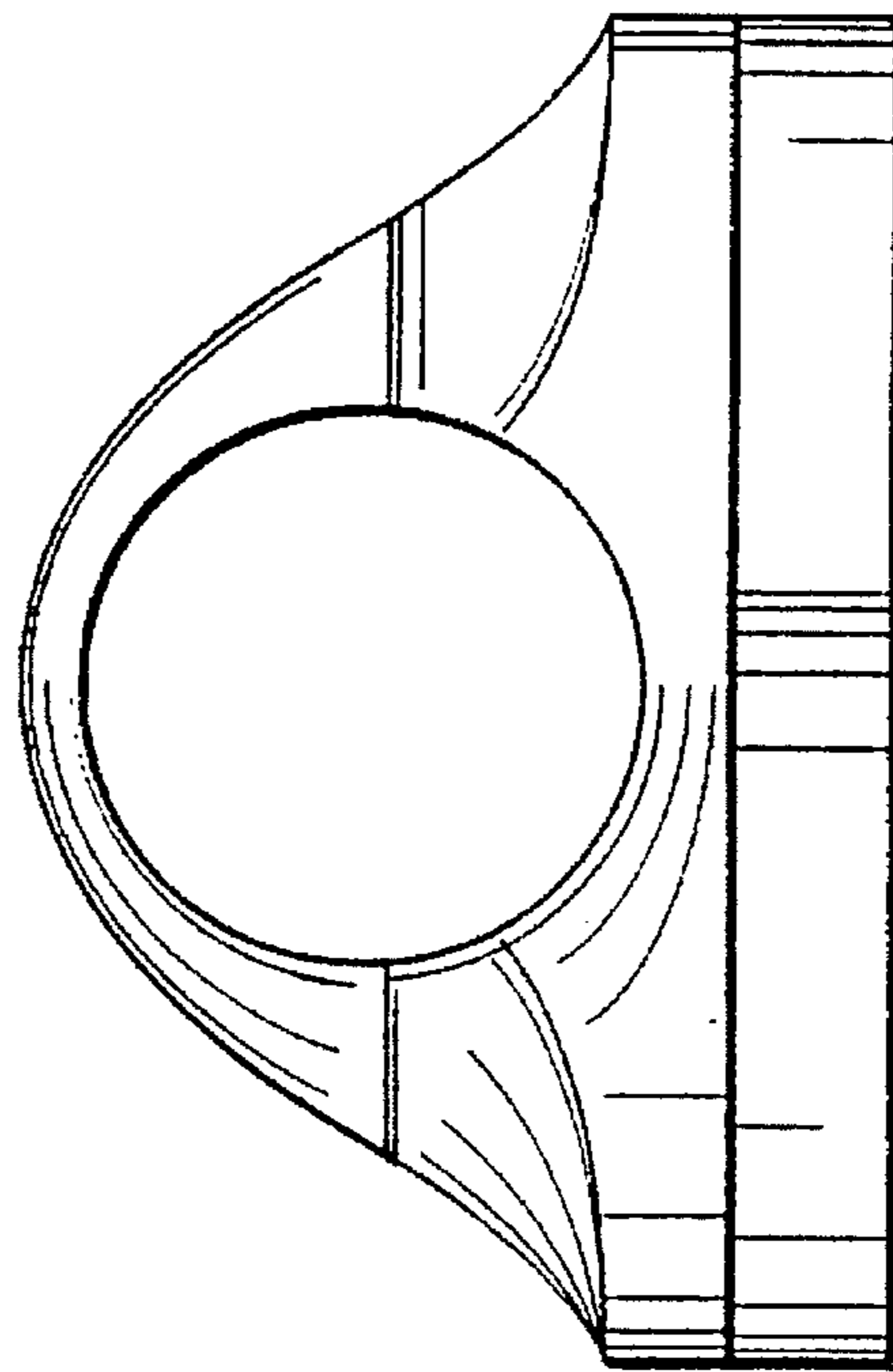

Fig. 5

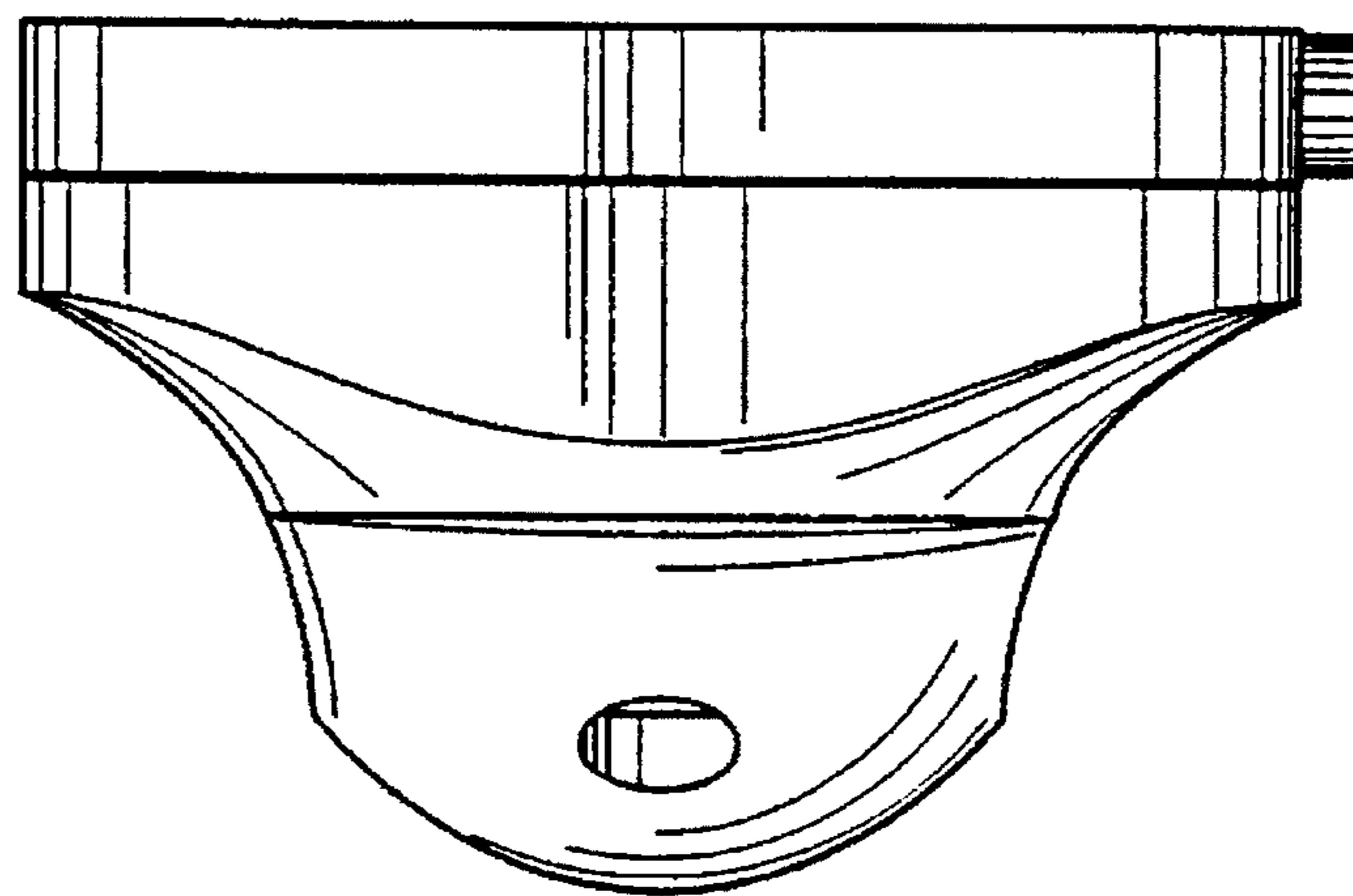

Fig. 6

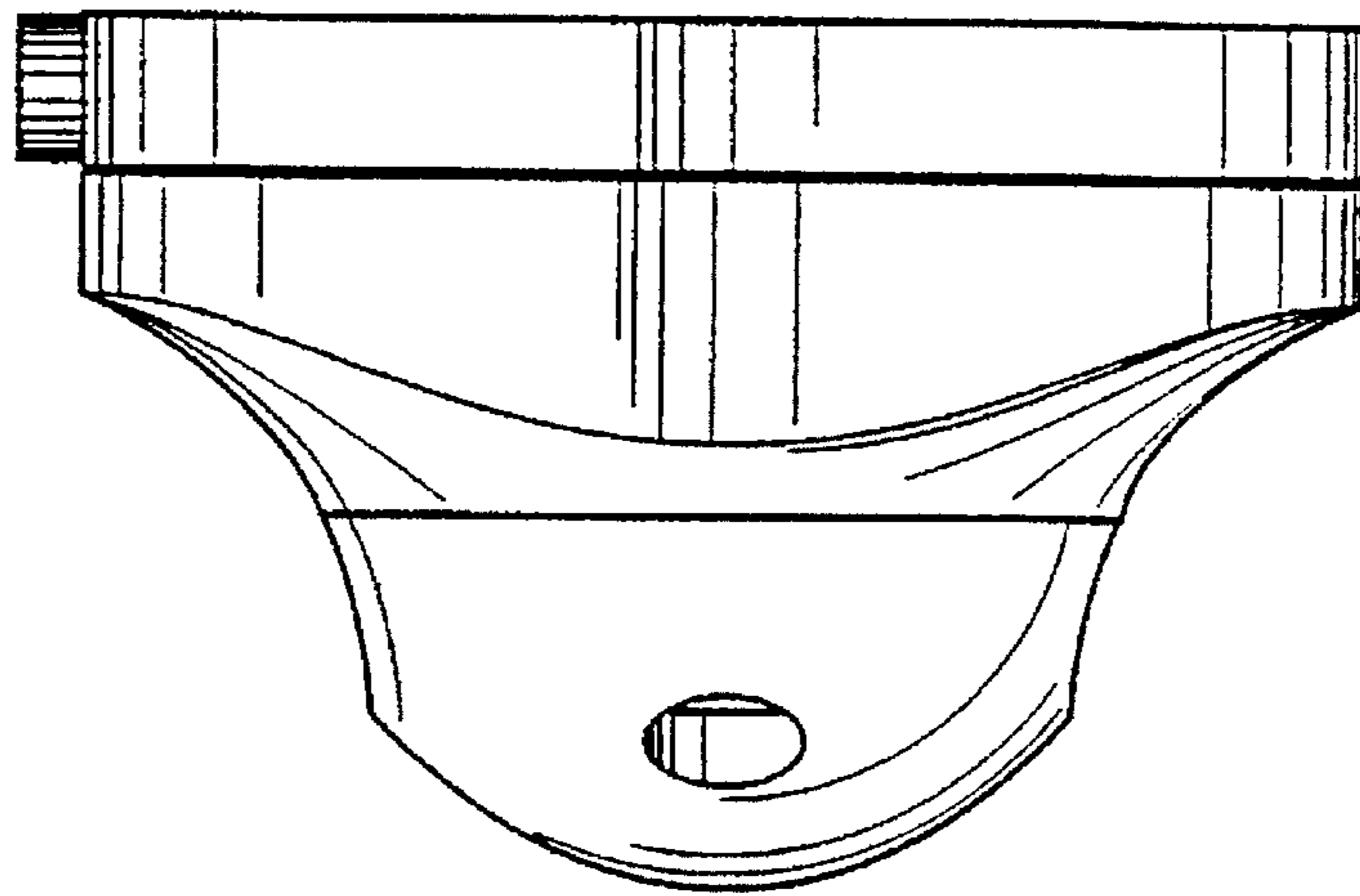

Fig. 7

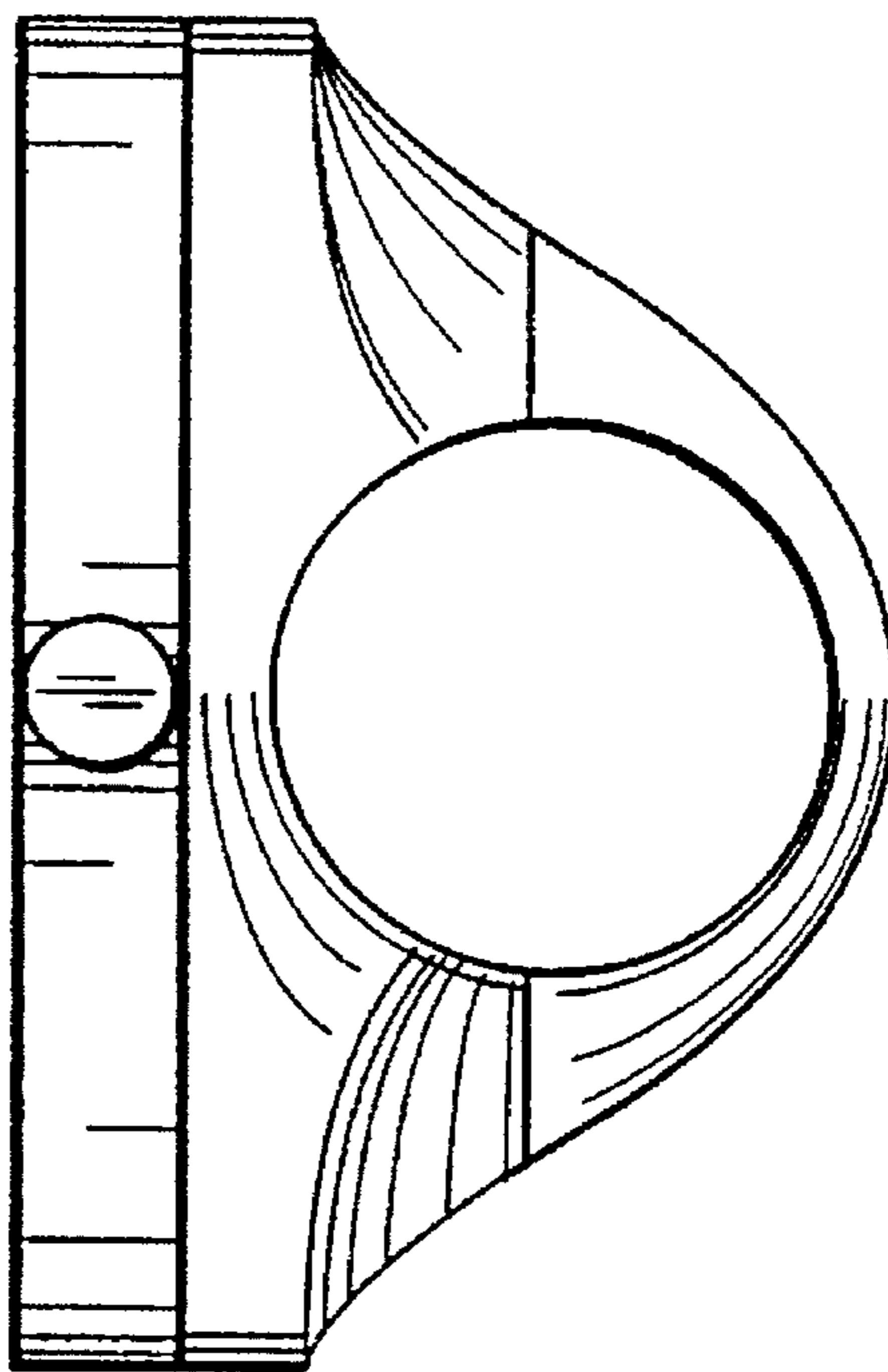

Fig. 8

Fig. 9

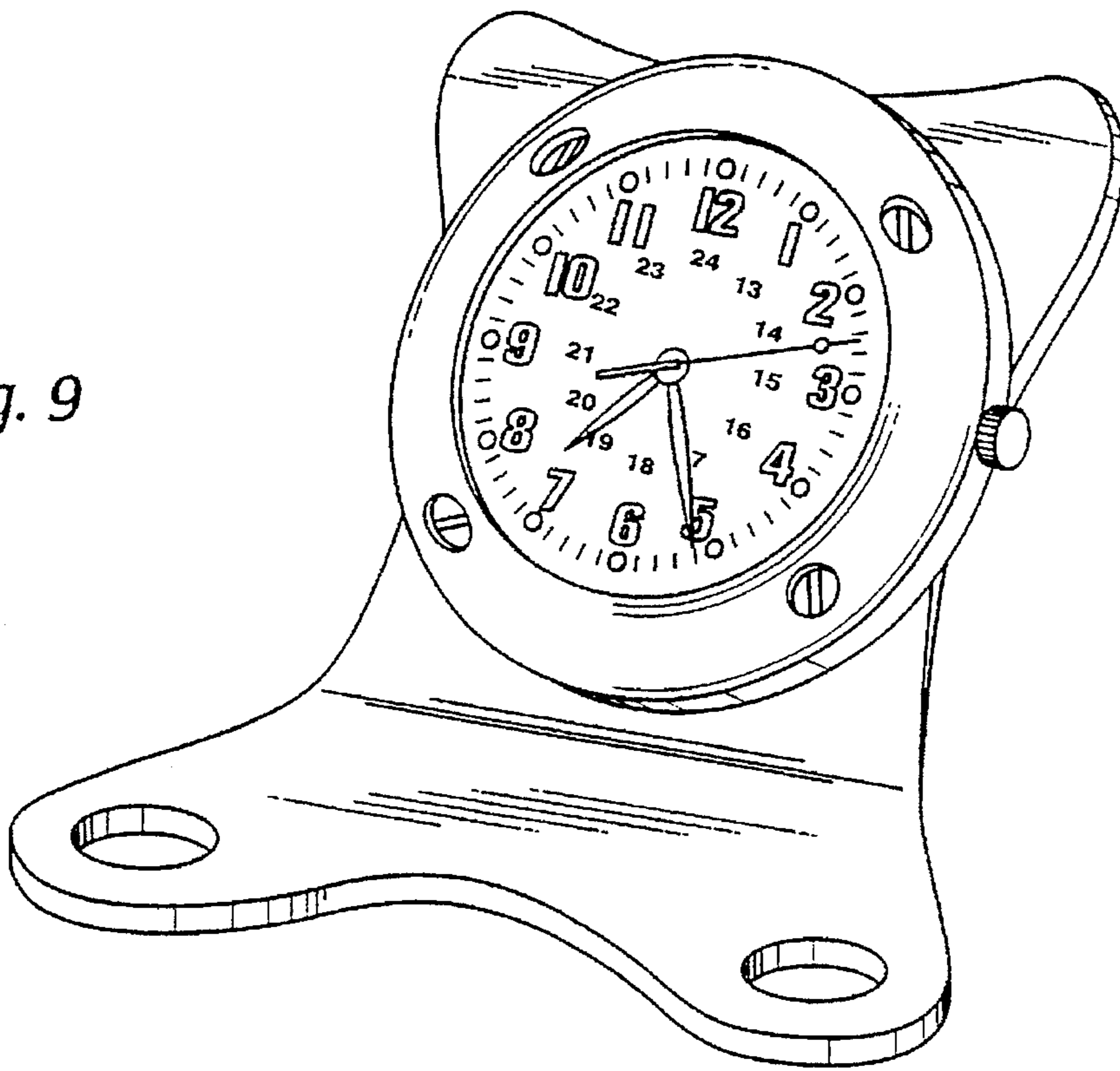
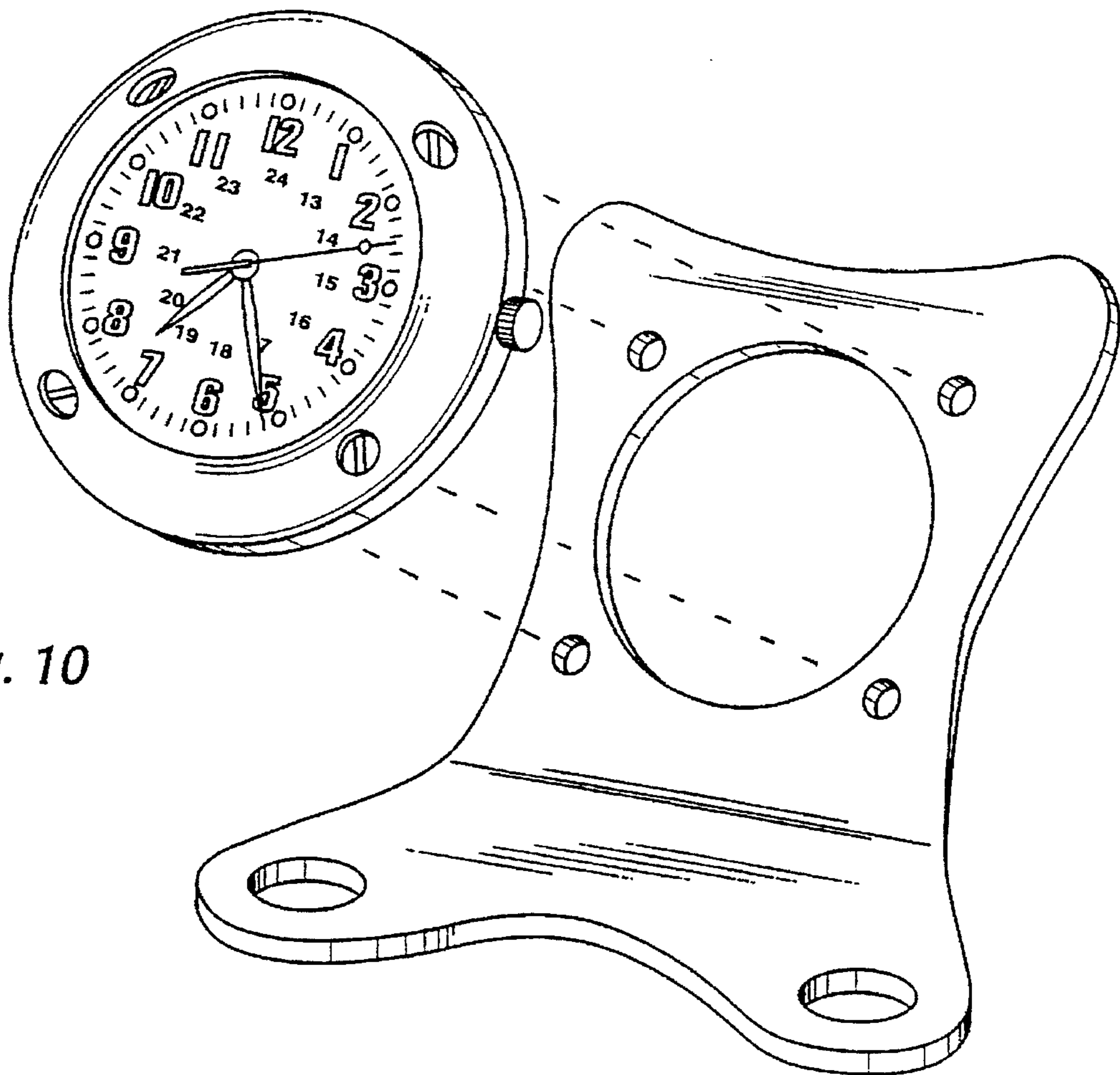

Fig. 10



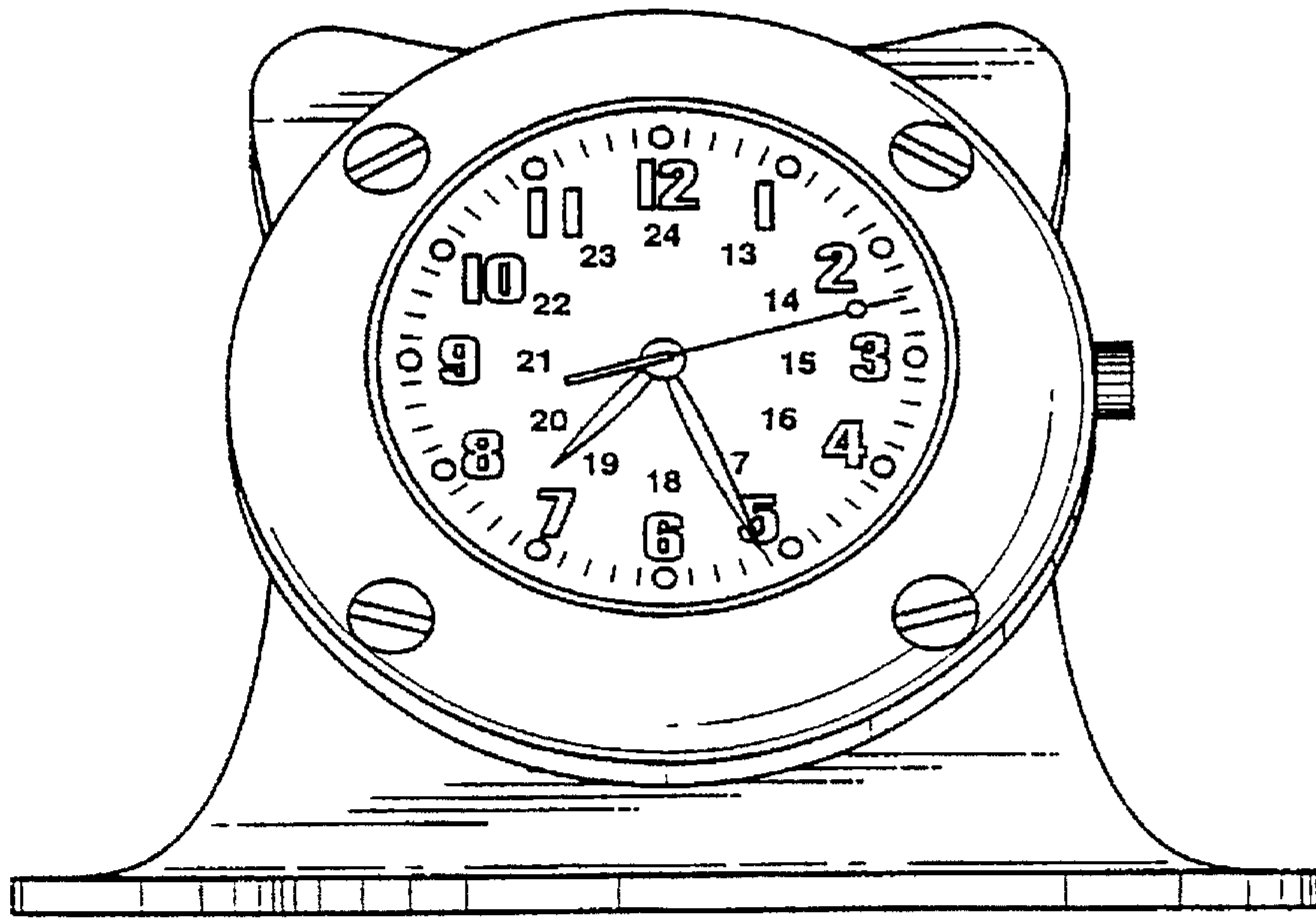

Fig. 11

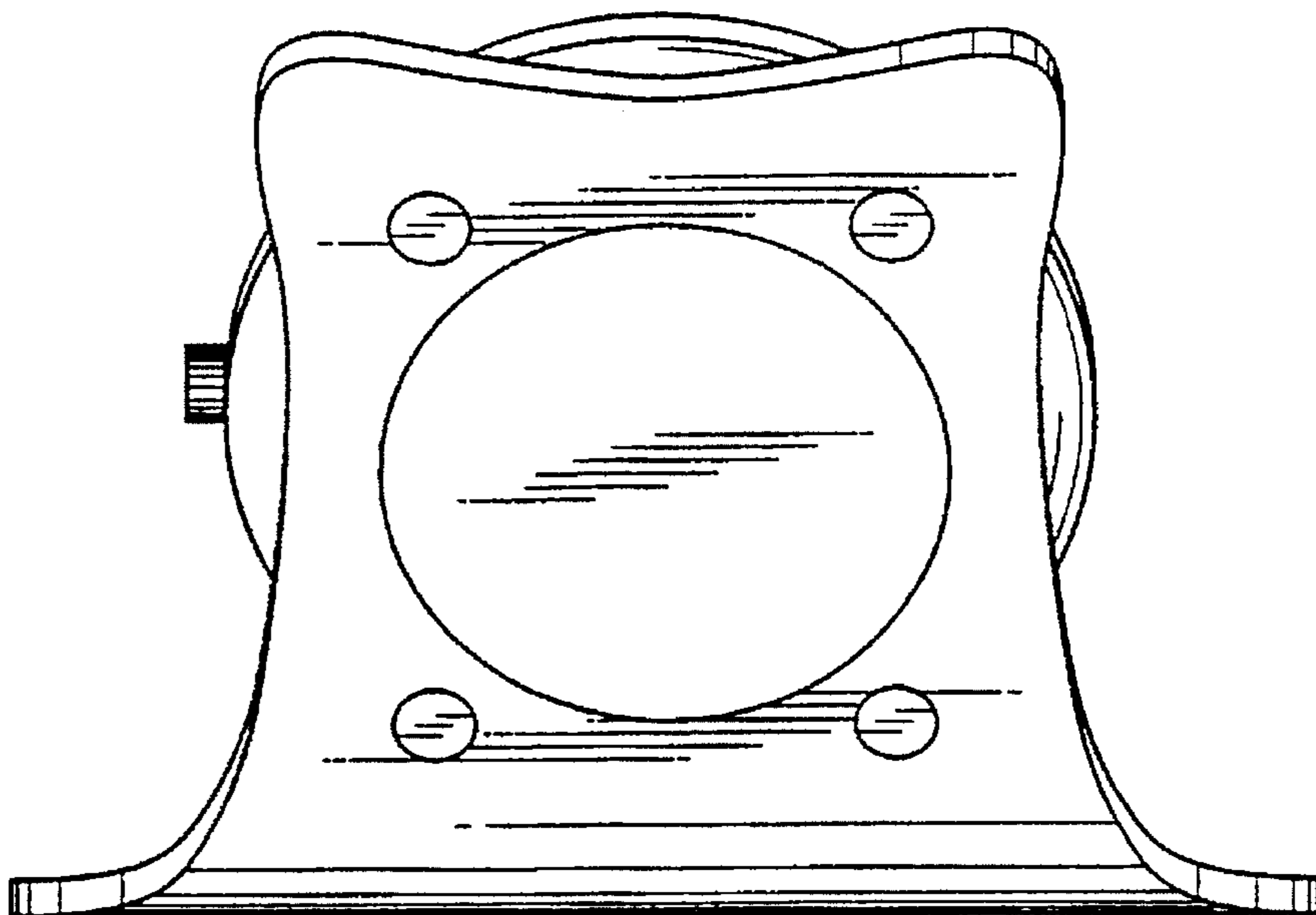

Fig. 12

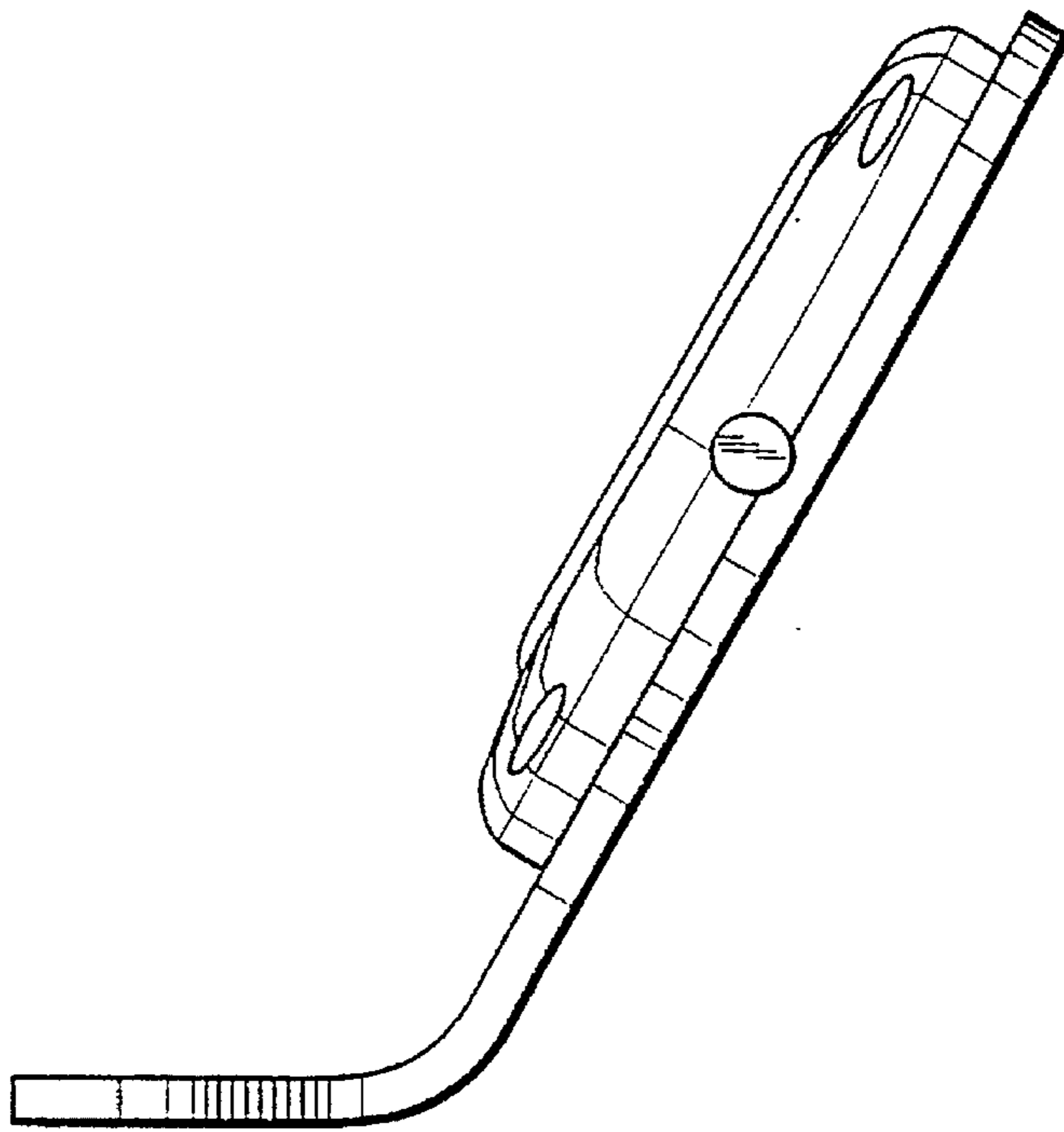

Fig. 13

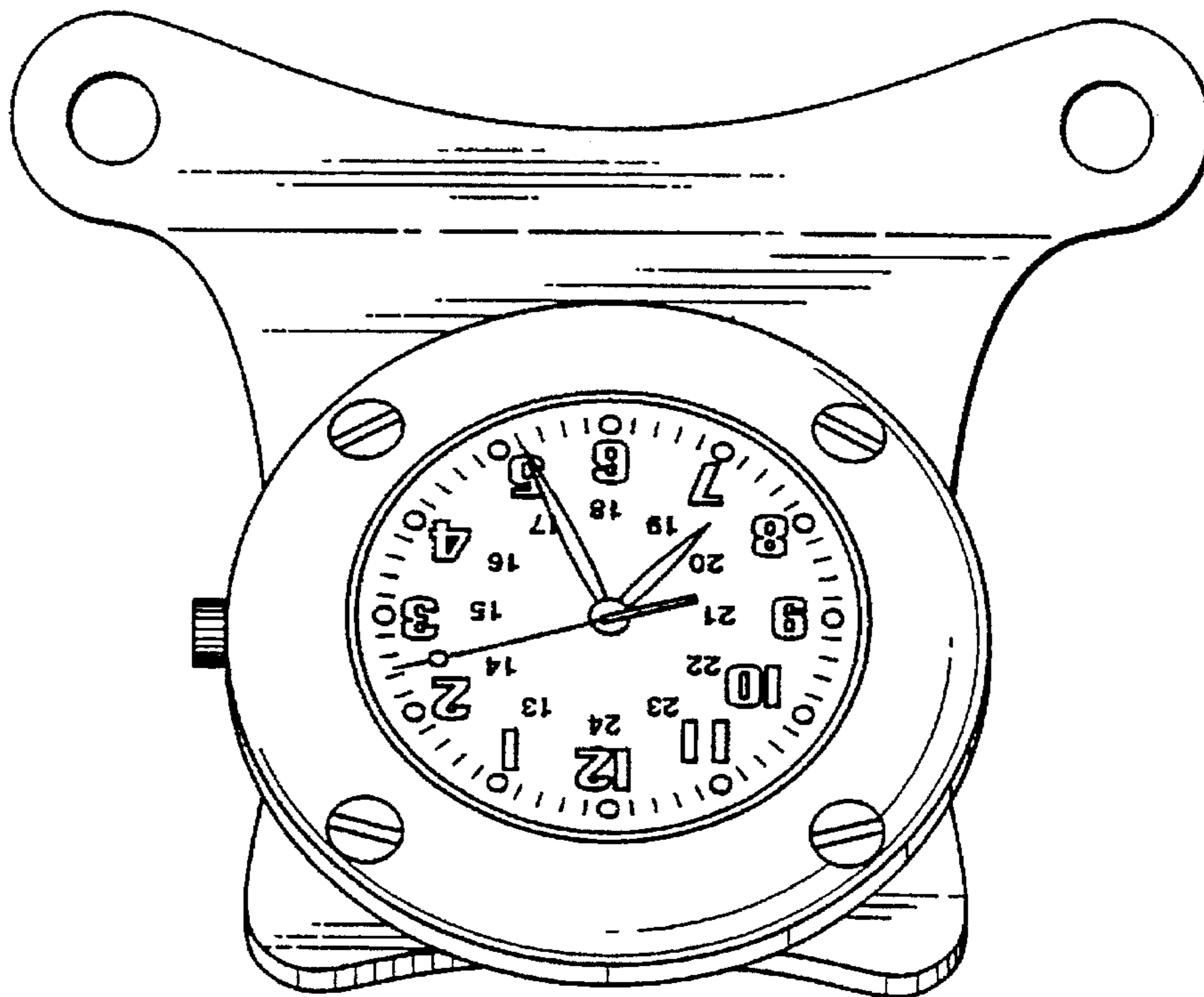

Fig. 14

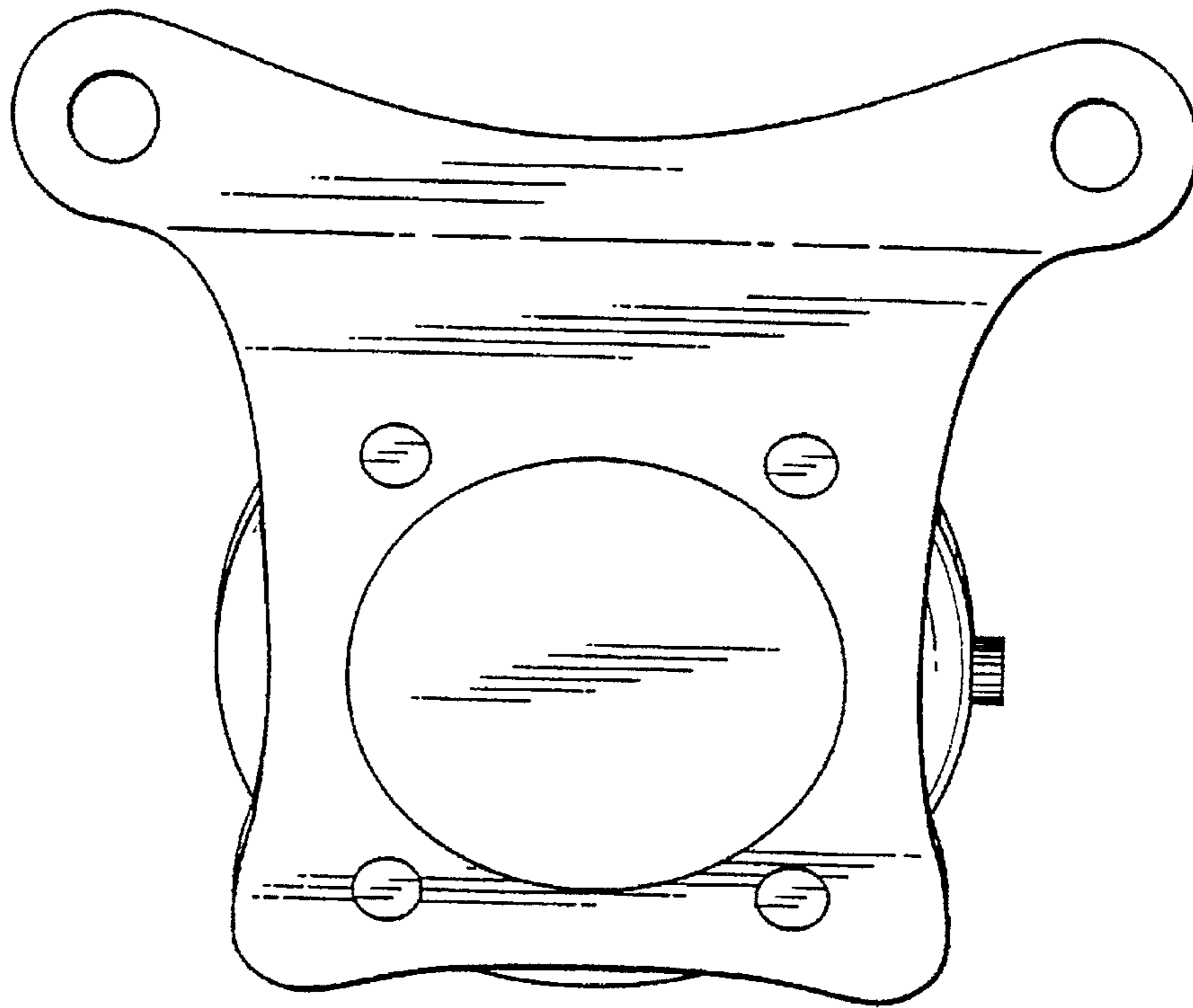

Fig. 15

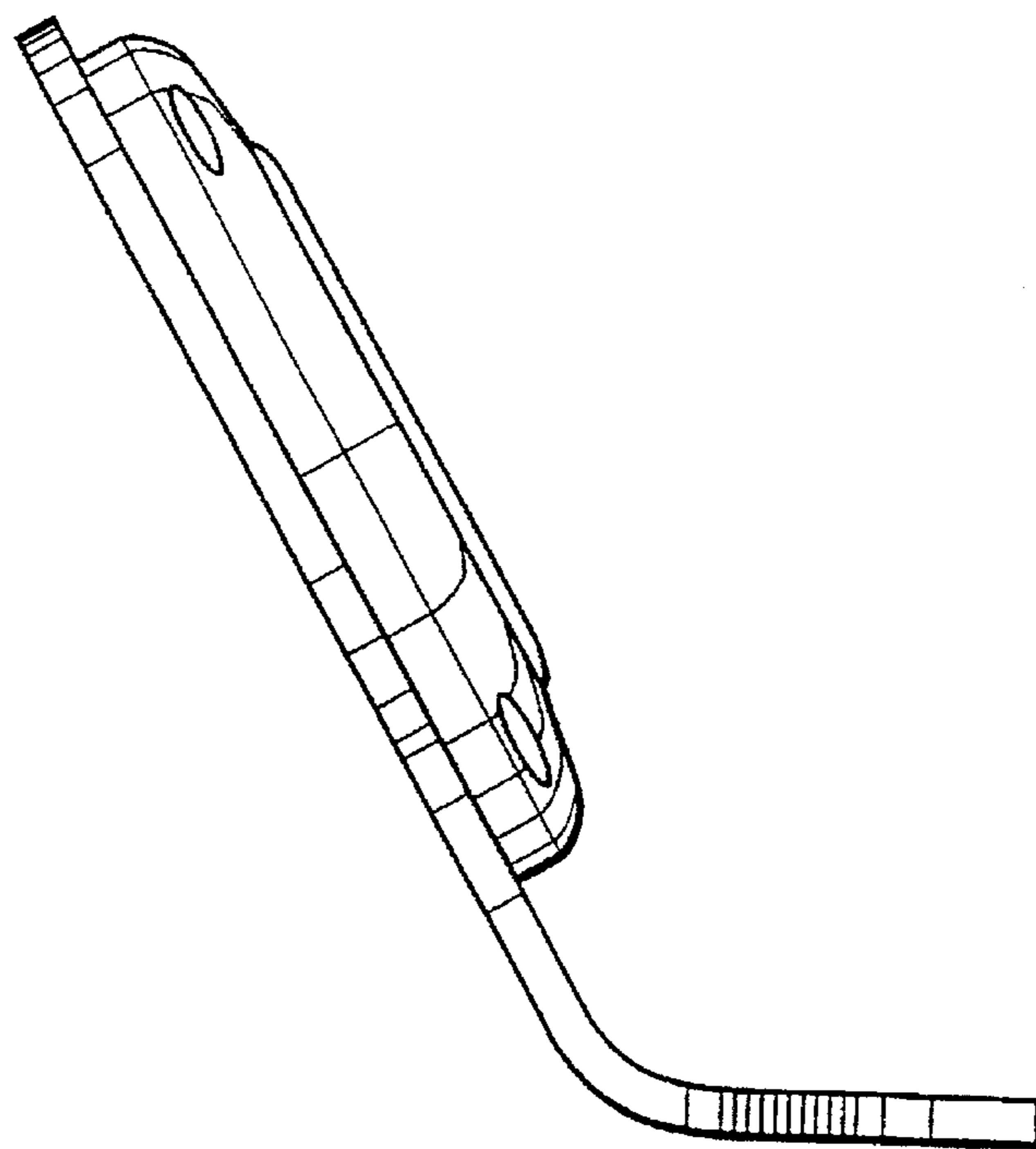

Fig. 16