



US00D381709S

United States Patent [19]

Petersson

[11] Patent Number: **Des. 381,709**

[45] Date of Patent: ****Jul. 29, 1997**

[54] **TOY RAILROAD WAGON**

[75] Inventor: **Ingvar Petersson**, Killeberg, Sweden

[73] Assignee: **Brio AB**, Osby, Sweden

[**] Term: **14 Years**

[21] Appl. No.: **56,749**

[22] Filed: **Jul. 8, 1996**

[30] **Foreign Application Priority Data**

Jan. 25, 1996 [SE] Sweden 960173

[51] **LOC (6) Cl.** **21-01**

[52] **U.S. Cl.** **D21/129**

[58] **Field of Search** D21/76, 78, 79,
D21/128, 129, 134, 136, 143; 446/137,
138, 410, 447, 467, 470, 168; 104/DIG. 1;
105/1.5

[56] **References Cited**

U.S. PATENT DOCUMENTS

D. 128,493 7/1941 Larrabee D21/129

D. 236,523	8/1975	Reiling	D21/129
D. 263,632	3/1982	Barberry, Jr. et al.	D21/129
2,055,846	9/1936	Marx	D21/129
2,939,245	6/1960	Orel	446/467
3,466,797	9/1969	Hellsund	446/410

OTHER PUBLICATIONS

Brio Wooden Railway Catalog 1993 p. 18 Train #33310.

Primary Examiner—Raphael Barkai

Attorney, Agent, or Firm—Barnes, Kisselle, Raisch, Choate, Whittemore & Hulbert, P.C.

[57] **CLAIM**

The ornamental design for a toy railroad wagon, as shown and described.

DESCRIPTION

FIG. 1 is a top perspective view of the top side, the right side and the front side of a toy railroad wagon showing my new design, the side opposite being a mirror image; and, FIG. 2 is a perspective view of the underside, the left side and the rear side of the toy railroad wagon, the side opposite being a mirror image.

1 Claim, 1 Drawing Sheet

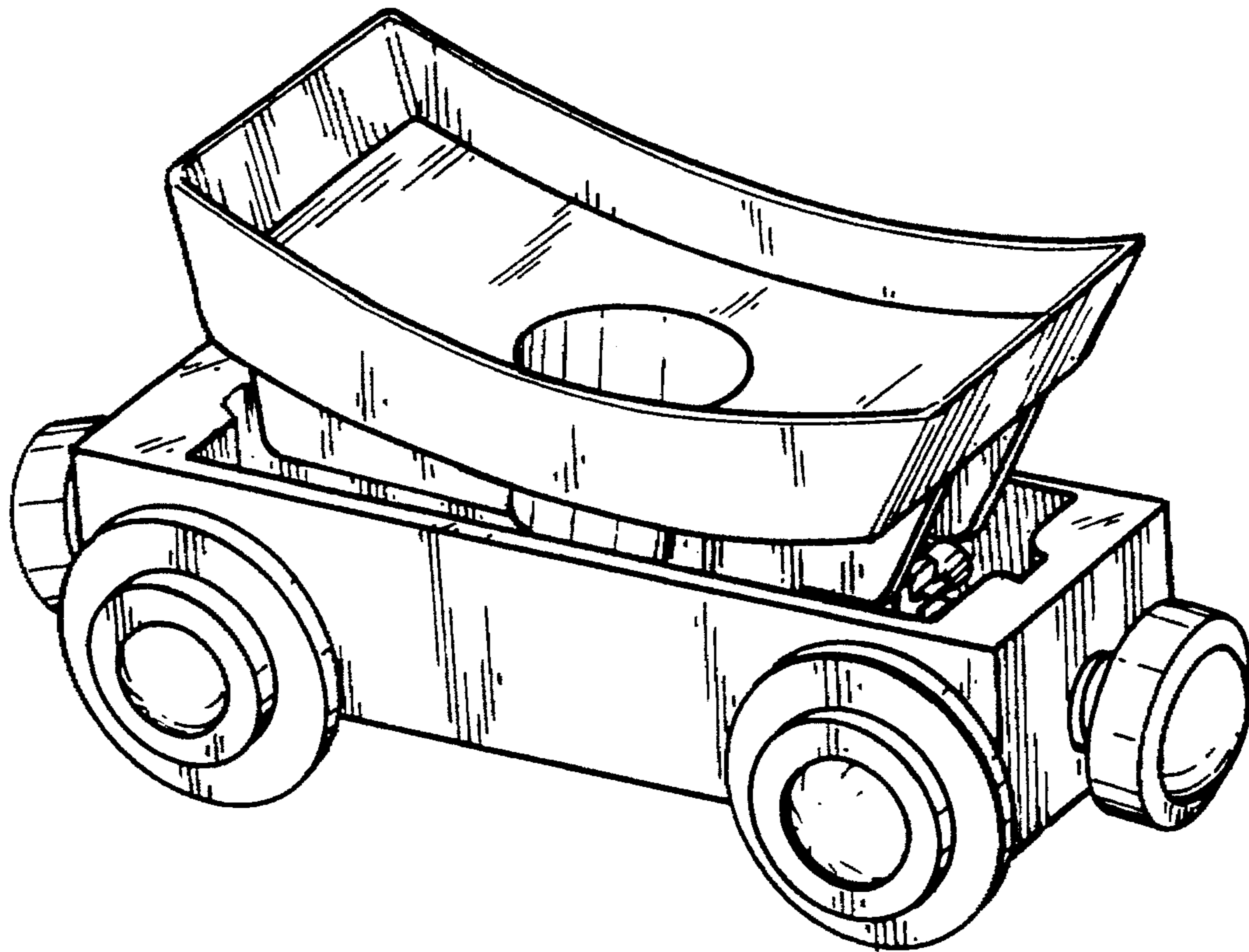

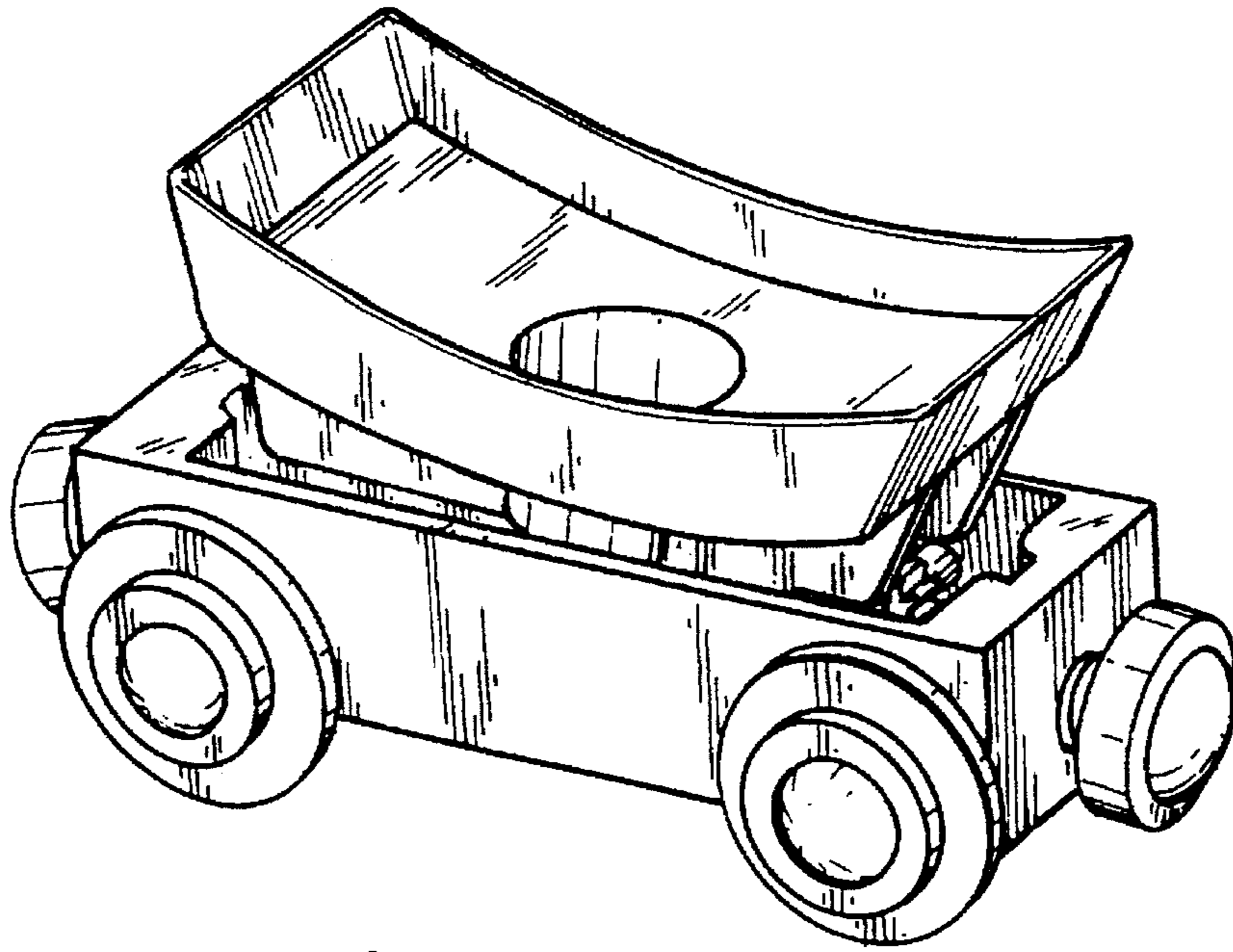

Fig. 1

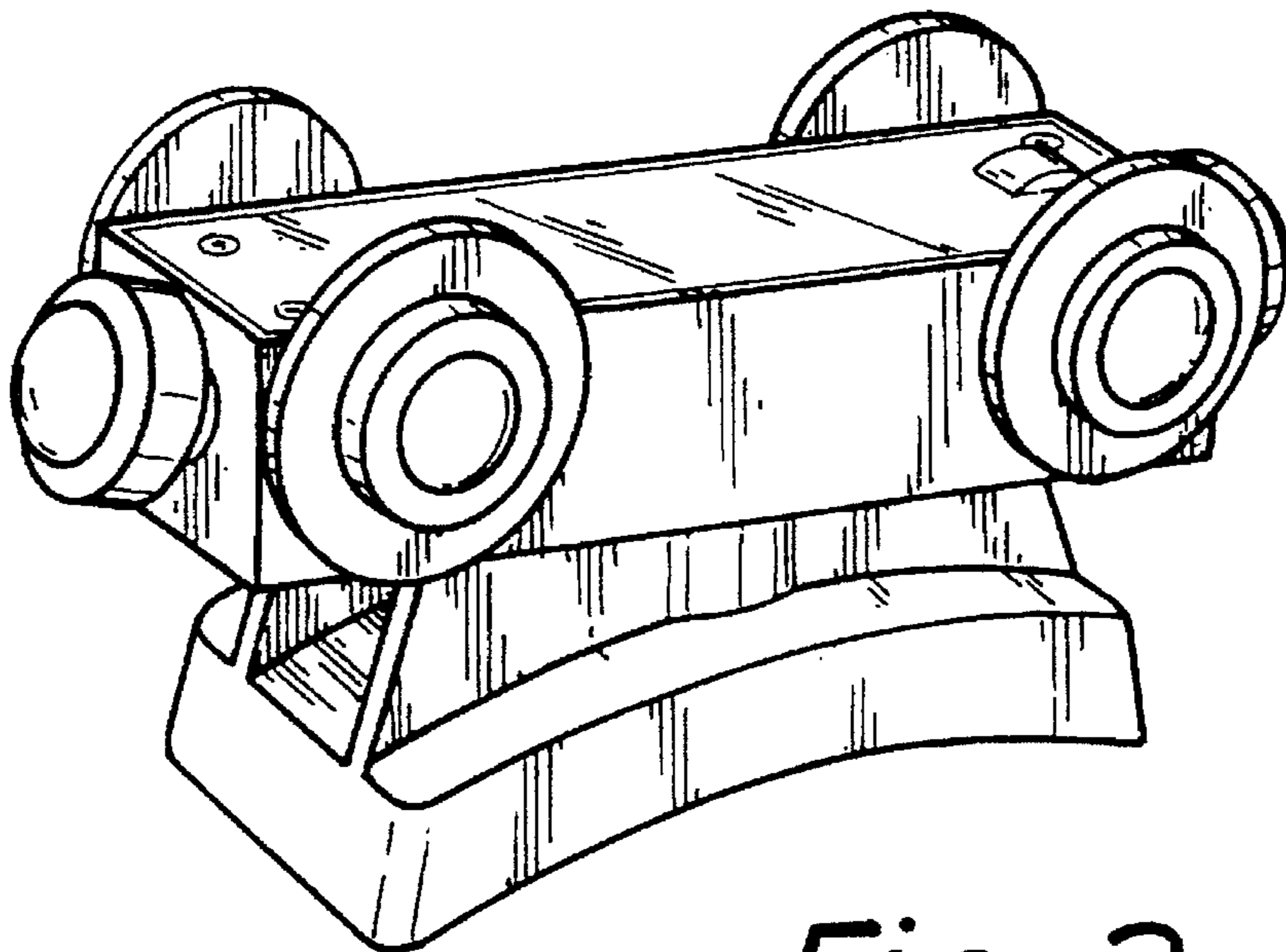

Fig. 2