



US00D381619S

United States Patent [19]

Otsuka et al.

[11] Patent Number: **Des. 381,619**

[45] Date of Patent: ****Jul. 29, 1997**

[54] **DRAIN CLIP FOR WEATHER STRIP OF AUTOMOBILE**

[75] Inventors: **Hiroyuki Otsuka**, Chiba-ken; **Yasuo Yamamoto**; **Kouichi Fukusima**, both of Kanagawa-ken, all of Japan

[73] Assignee: **Nifco, Inc.**, Kanagawa-ken, Japan

[**] Term: **14 Years**

[21] Appl. No.: **39,418**

[22] Filed: **May 30, 1995**

[30] **Foreign Application Priority Data**

Nov. 30, 1994 [JP] Japan 6-36525

[51] **LOC (6) Cl.** **12-06**

[52] **U.S. Cl.** **D12/223**

[58] **Field of Search** D12/223, 400; D8/300, 349, 371, 354, 356; 296/100, 37.1; 248/300

[56] **References Cited**

U.S. PATENT DOCUMENTS

D. 224,826	9/1972	Kamins et al.	D8/371
D. 258,562	3/1981	DeStepheno	D12/223
D. 283,294	4/1986	Bancroft	D8/300
D. 304,567	11/1989	Lane, Jr.	D12/223
D. 351,552	10/1994	Williams	D8/356
4,461,507	7/1984	Minami et al.	296/76
5,310,238	5/1994	Wheatley	296/100

OTHER PUBLICATIONS

JC Whitney & Co Catalog, ©1995 No 575c, p. 109, the sure-grip clamp for pickup trucks.

Primary Examiner—Melody N. Brown
Attorney, Agent, or Firm—Sughrue, Mion, Zinn, Macpeak & Seas

[57] **CLAIM**

The ornamental design for a drain clip for weather strip of automobile, as shown and described.

DESCRIPTION

FIG. 1 is a top plan view of a drain clip for weather strip of automobile showing our new design;

FIG. 2 is a front elevational view thereof;

FIG. 3 is a bottom plan view thereof;

FIG. 4 is a rear elevational view thereof;

FIG. 5 is a right side elevational view, the left side elevational view being a mirror image thereof;

FIG. 6 is a sectional view taken along the line 6—6 in FIG. 2;

FIG. 7 is a sectional view taken along the line 7—7 in FIG. 2;

FIG. 8 is a perspective view of the bottom rear and one side thereof; and,

FIG. 9 is a side elevational view in conjunction with a weather strip and automobile body panel shown in broken sectional lines.

The broken lines shown in the view of FIG. 9 are for illustrative purposes only and form no part of the claimed design.

1 Claim, 2 Drawing Sheets

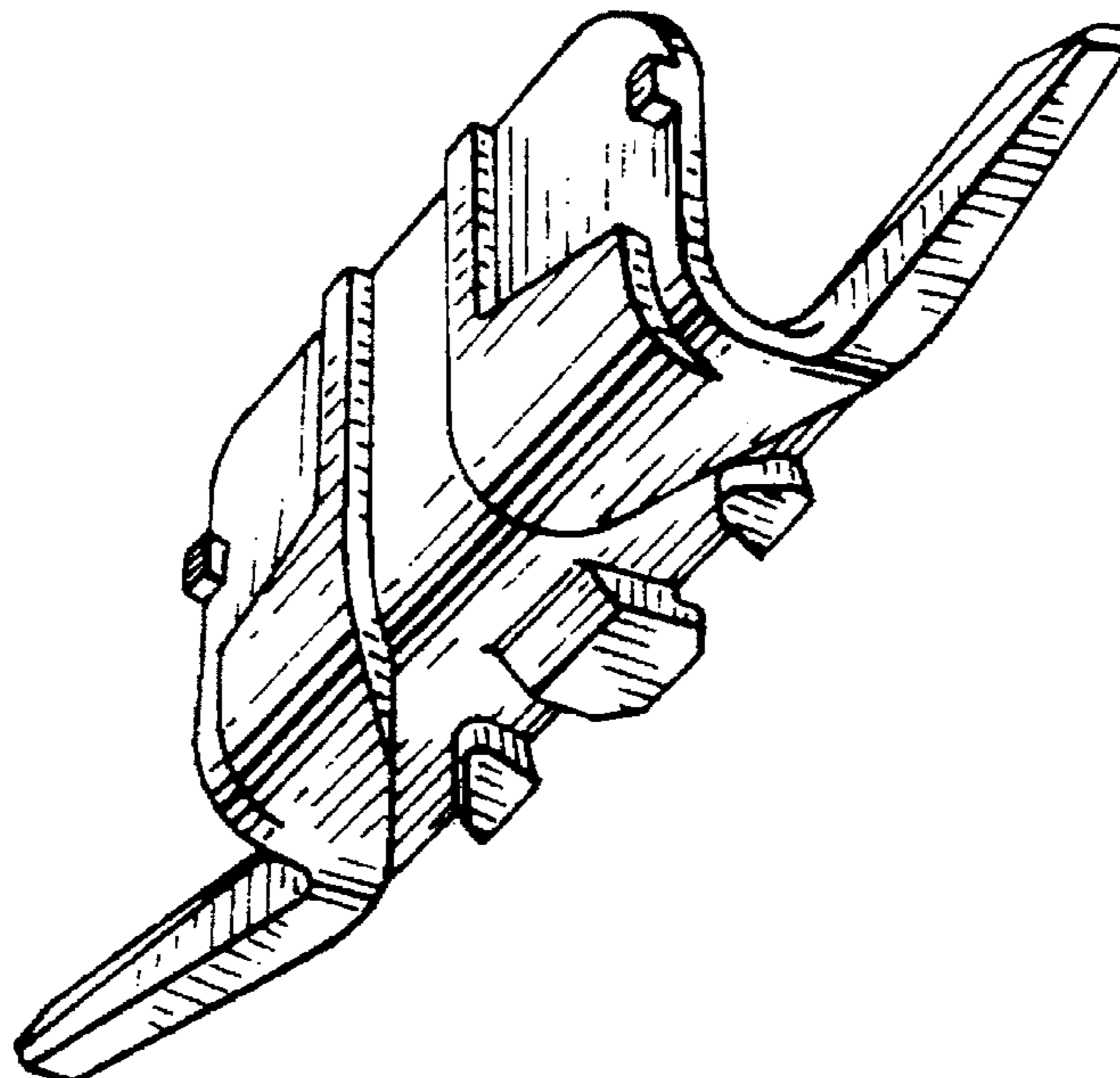

FIG. 1

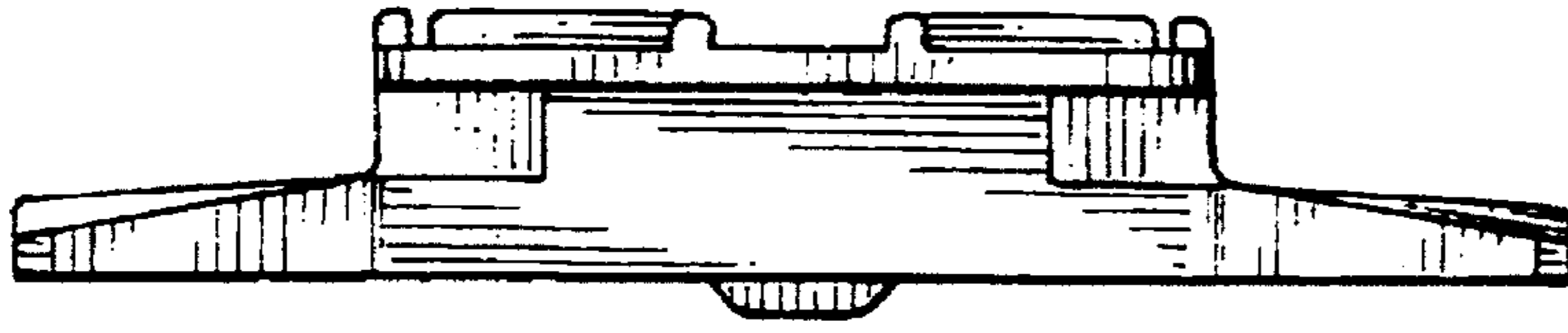

FIG. 2

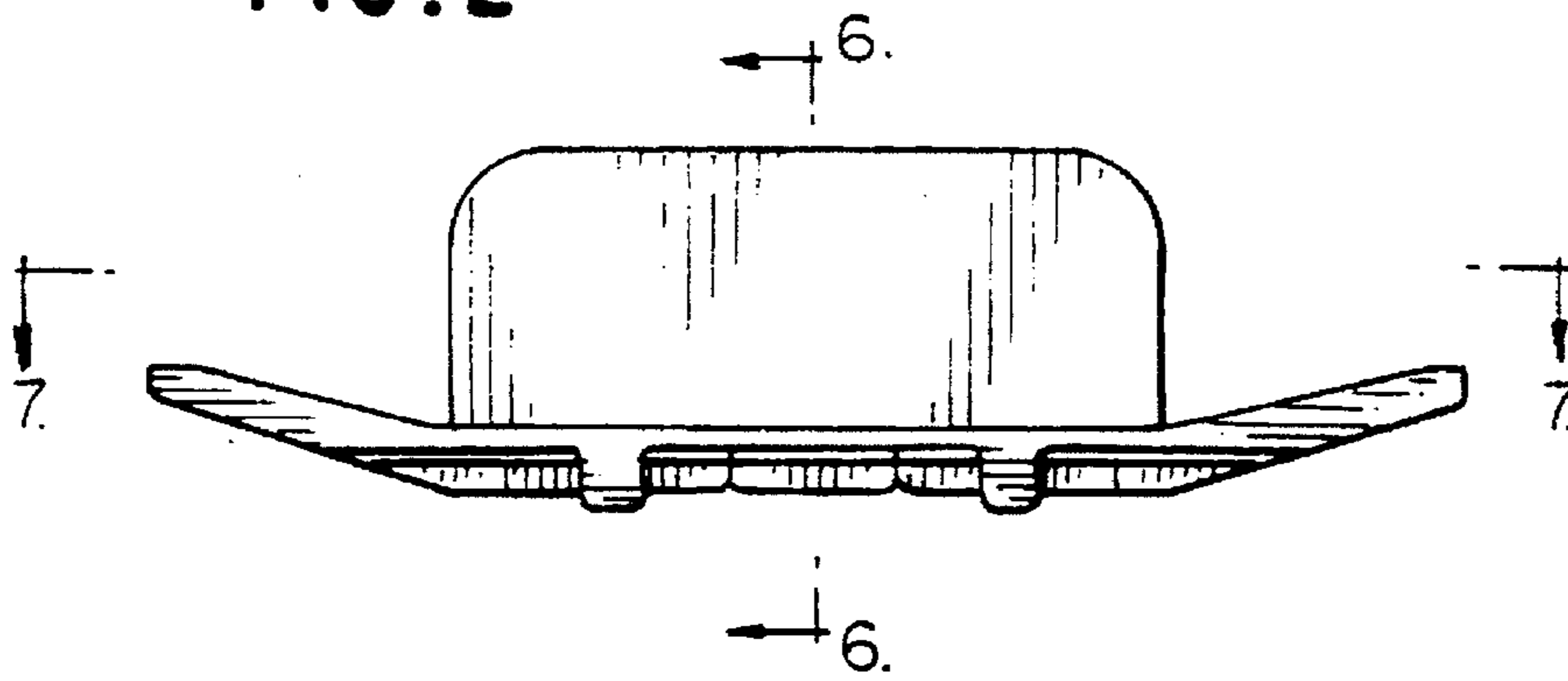

FIG. 5

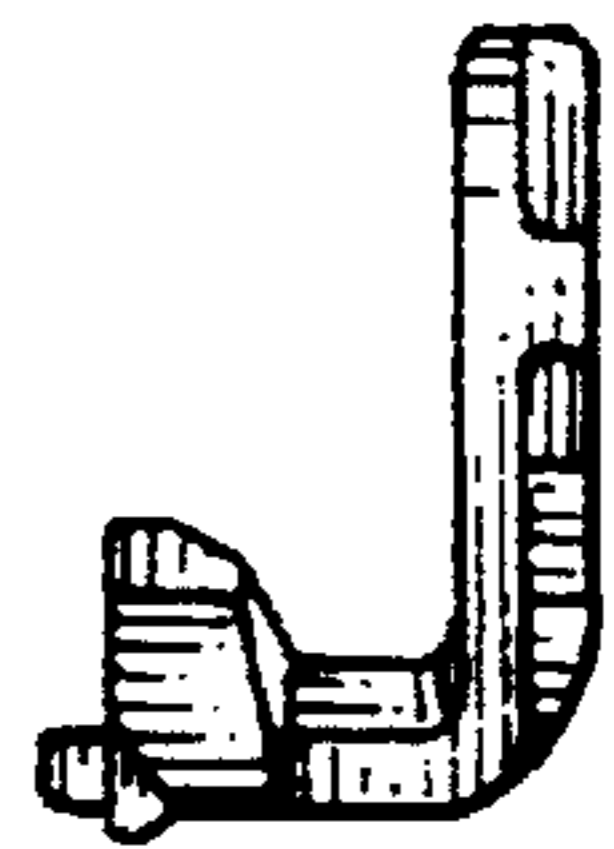

FIG. 3

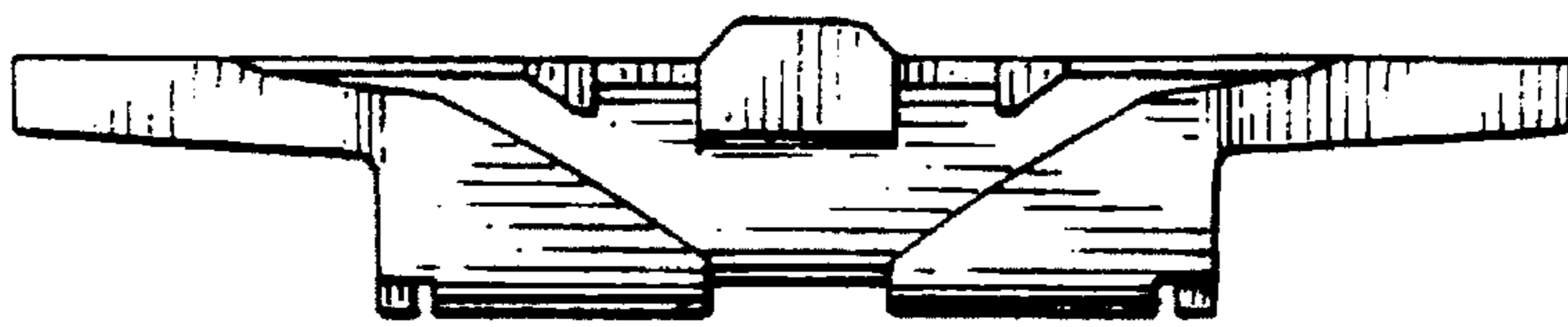

FIG. 6

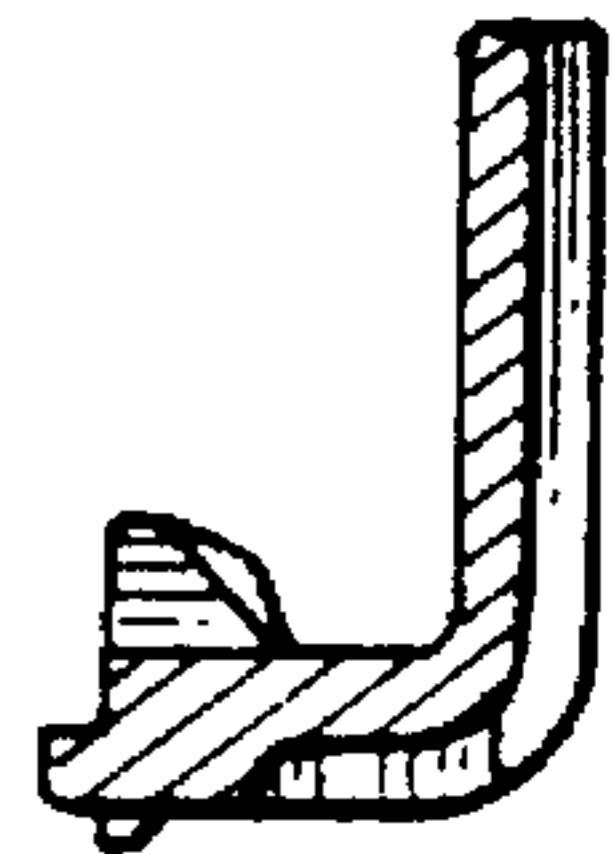

FIG. 4

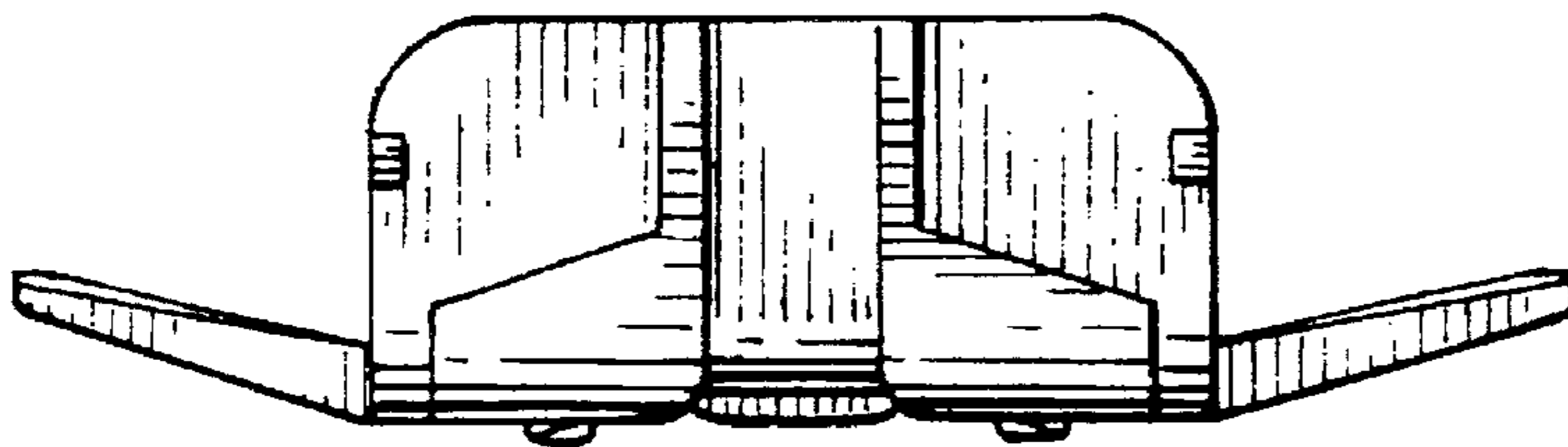

FIG. 7

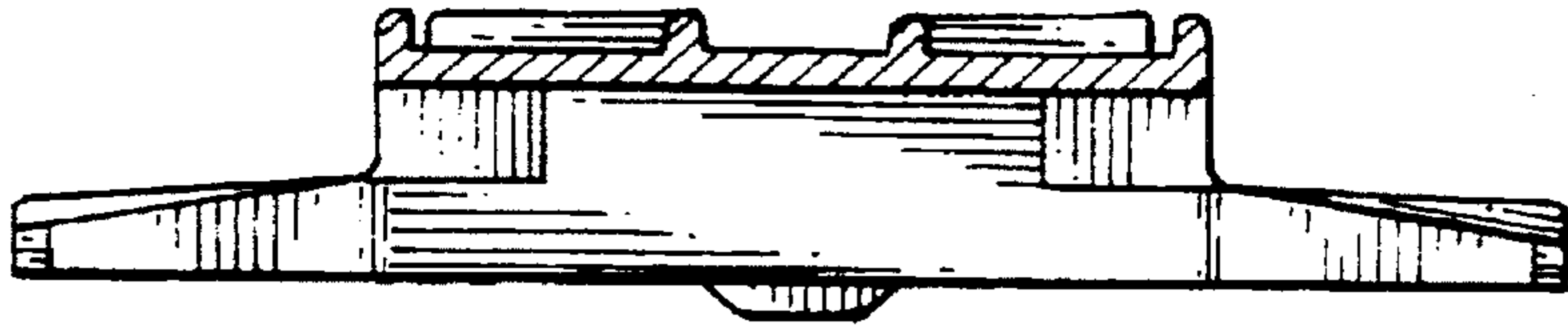

FIG. 8

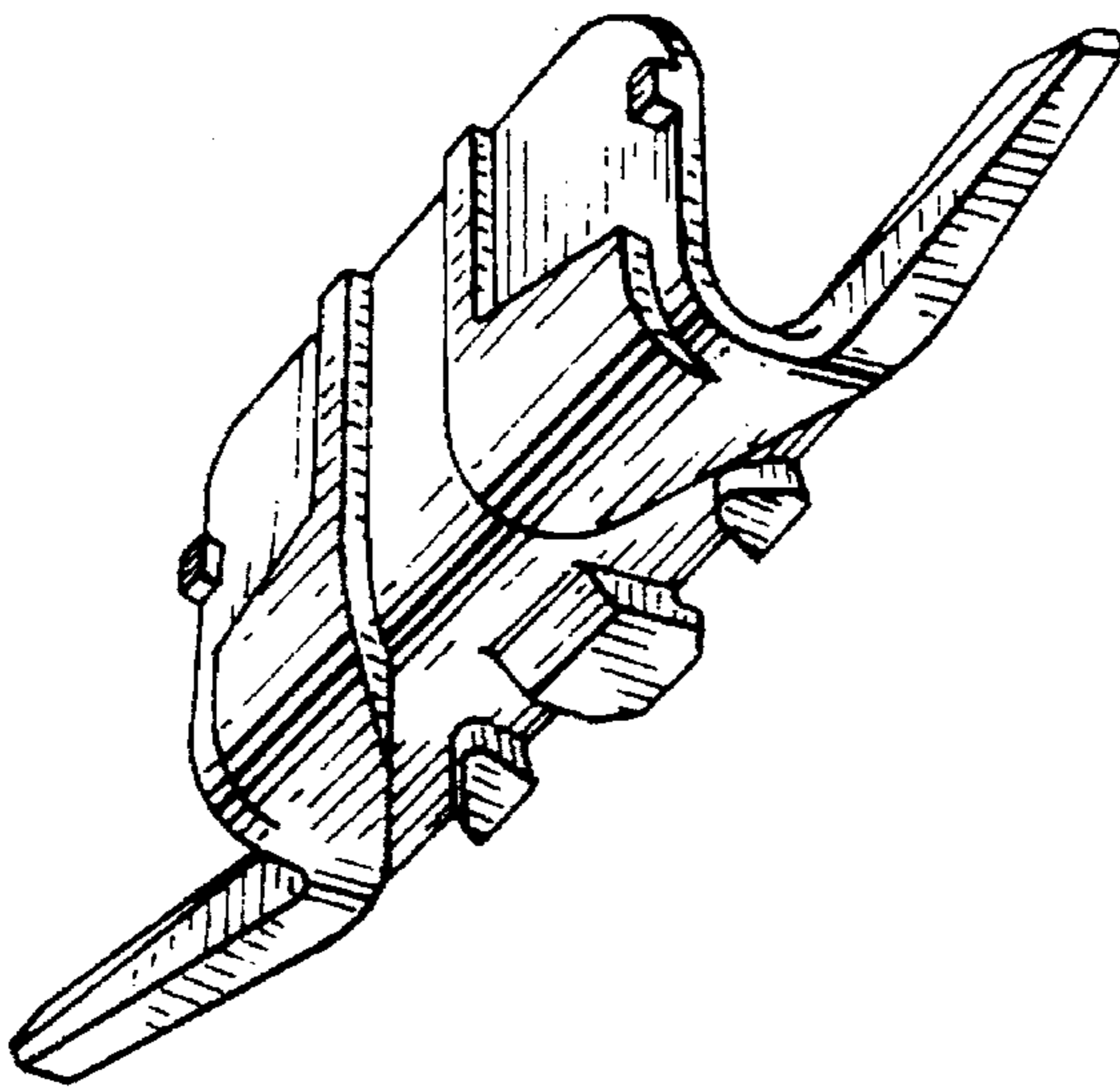

FIG. 9

