



US00D381617S

United States Patent [19]

Echazabal et al.

[11] Patent Number: **Des. 381,617**

[45] Date of Patent: ****Jul. 29, 1997**

[54] **VEHICLE WHEEL EXTERIOR SURFACE**

[75] Inventors: **Alberto Echazabal**, Miramar, Fla.;
Claudio Bernoni, Albano Terma, Italy

[73] Assignee: **Motoring Accessories, Inc.**, Miami, Fla.

[**] Term: **14 Years**

[21] Appl. No.: **43,449**

[22] Filed: **Aug. 30, 1995**

[51] LOC (6) Cl. **12-16**

[52] U.S. Cl. **D12/209**

[58] Field of Search D12/209, 211;
301/64.1, 65, 37.1

[56] **References Cited**

U.S. PATENT DOCUMENTS

- D. 267,564 1/1983 Wright D12/211
- D. 336,743 6/1993 Cattaneo D12/211
- D. 361,547 8/1995 Weld D12/211

OTHER PUBLICATIONS

1995 Performance Wheel Tire & Suspension Handbook, p. 58, See Evo Type 05.

Primary Examiner—James Gandy

Assistant Examiner—Stacia Sinuik

Attorney, Agent, or Firm—Longacre & White

[57] **CLAIM**

The ornamental design for the vehicle wheel exterior surface, as shown and described.

DESCRIPTION

FIG. 1 is a perspective view of the vehicle wheel exterior surface according to the present invention;

FIG. 2 is a front elevational view of the vehicle wheel exterior surface as shown in FIG. 1;

FIG. 3 is a perspective view of another embodiment of the vehicle wheel exterior surface according to the present invention; and,

FIG. 4 is an alternate front elevational view of the vehicle wheel exterior surface as shown in FIG. 3.

The broken line showing the environment is for illustrative purposes only and forms no part of the claimed design.

1 Claim, 2 Drawing Sheets

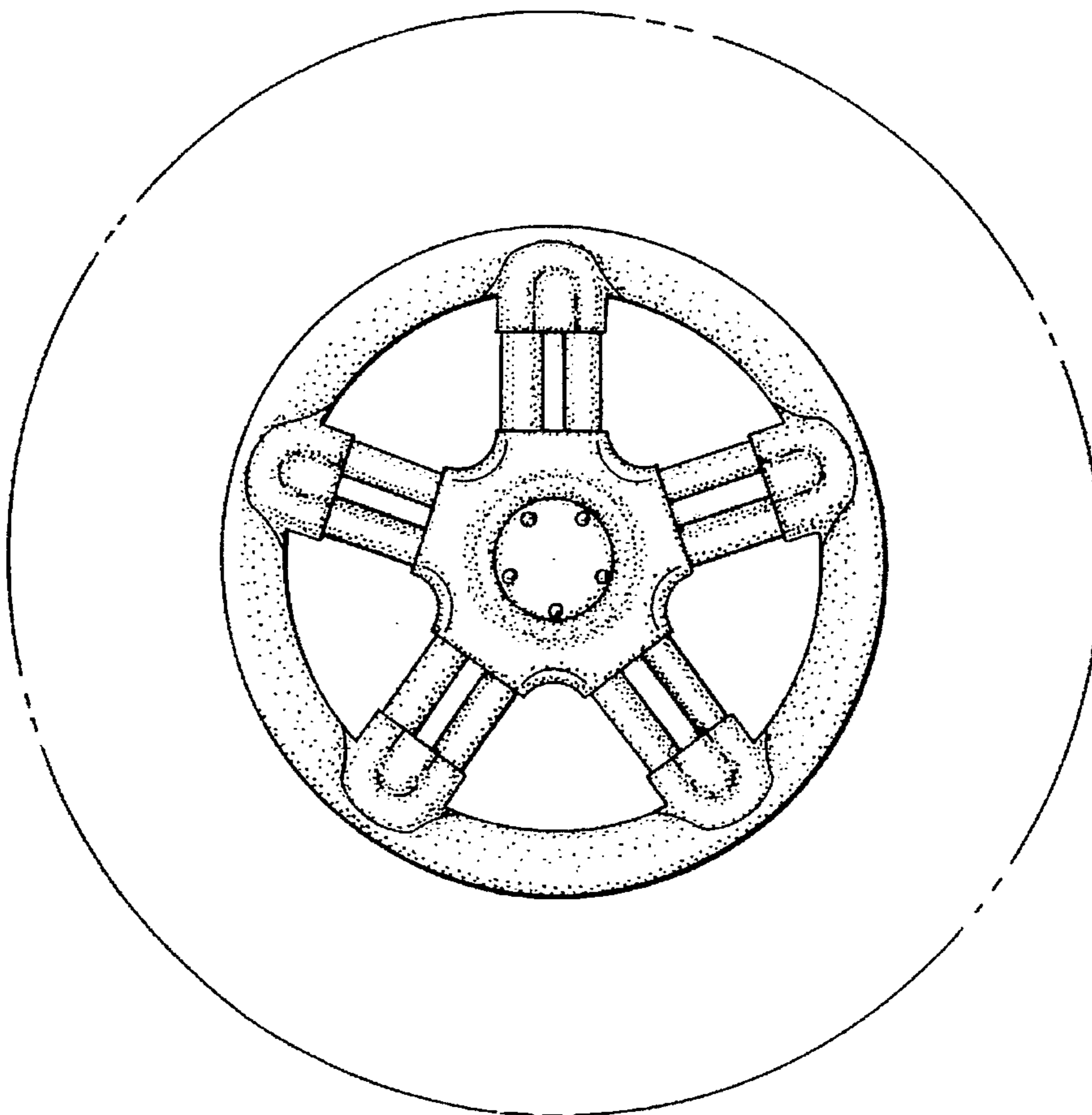

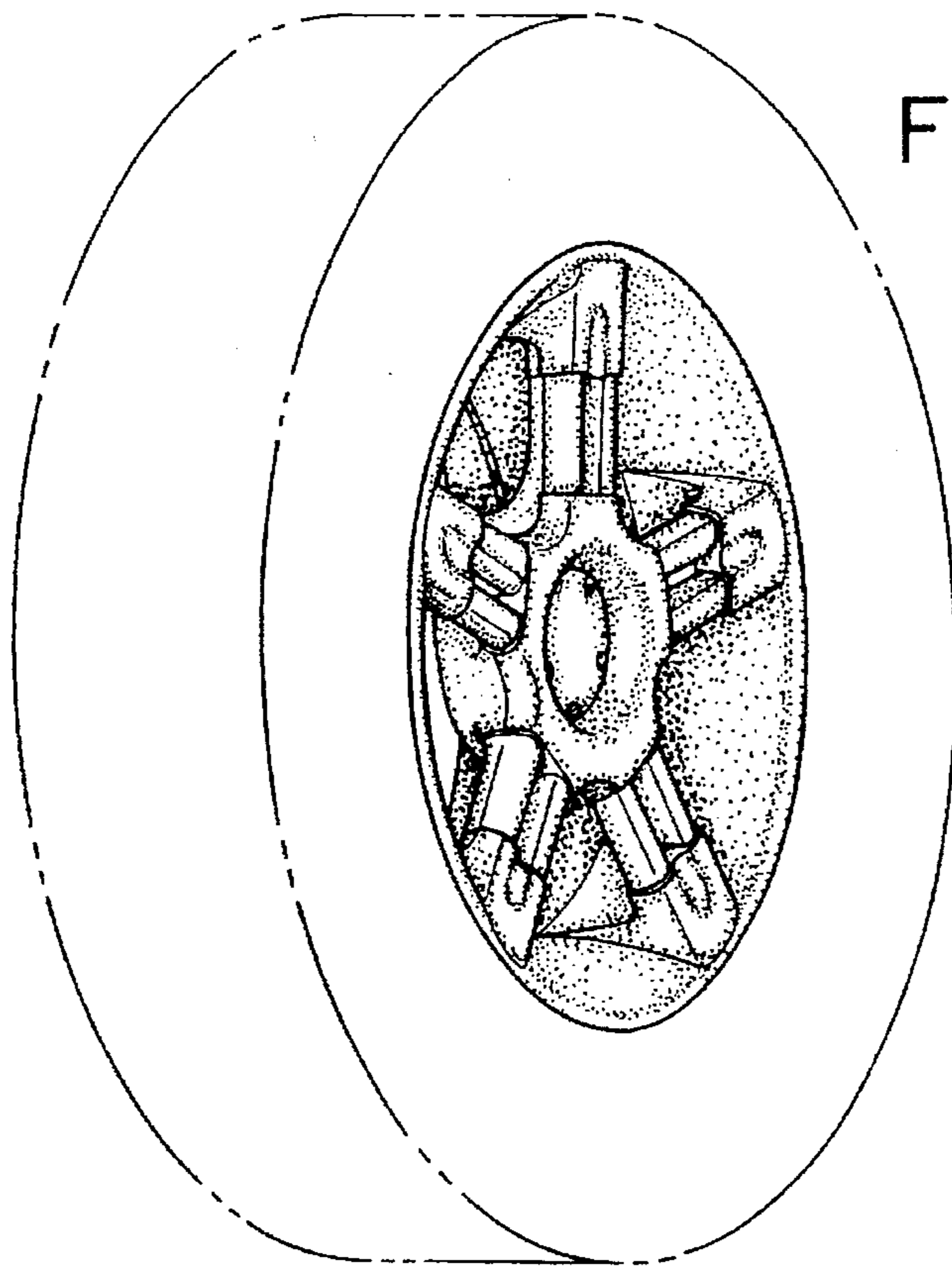

FIG. 1

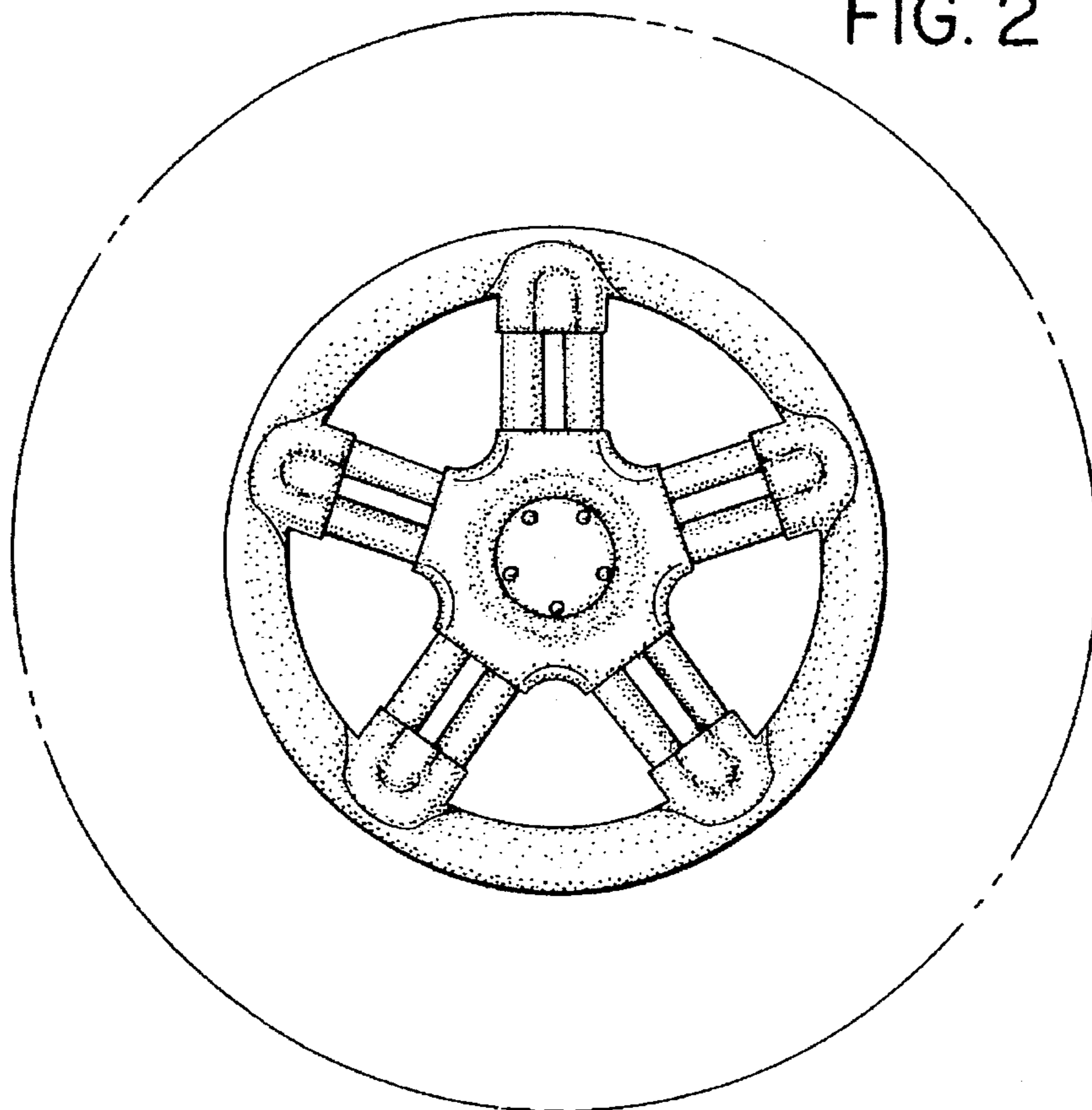

FIG. 2

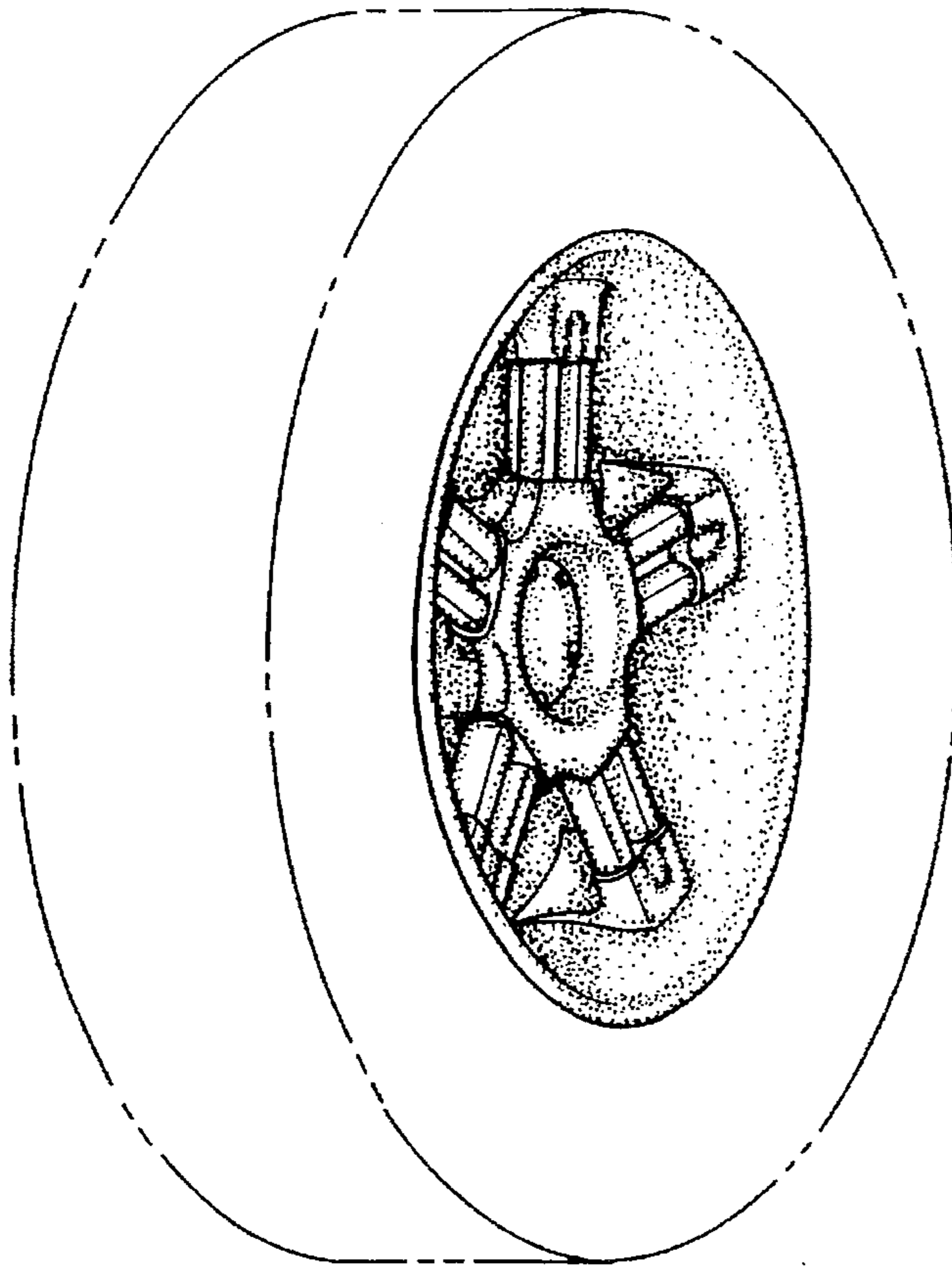

FIG. 3

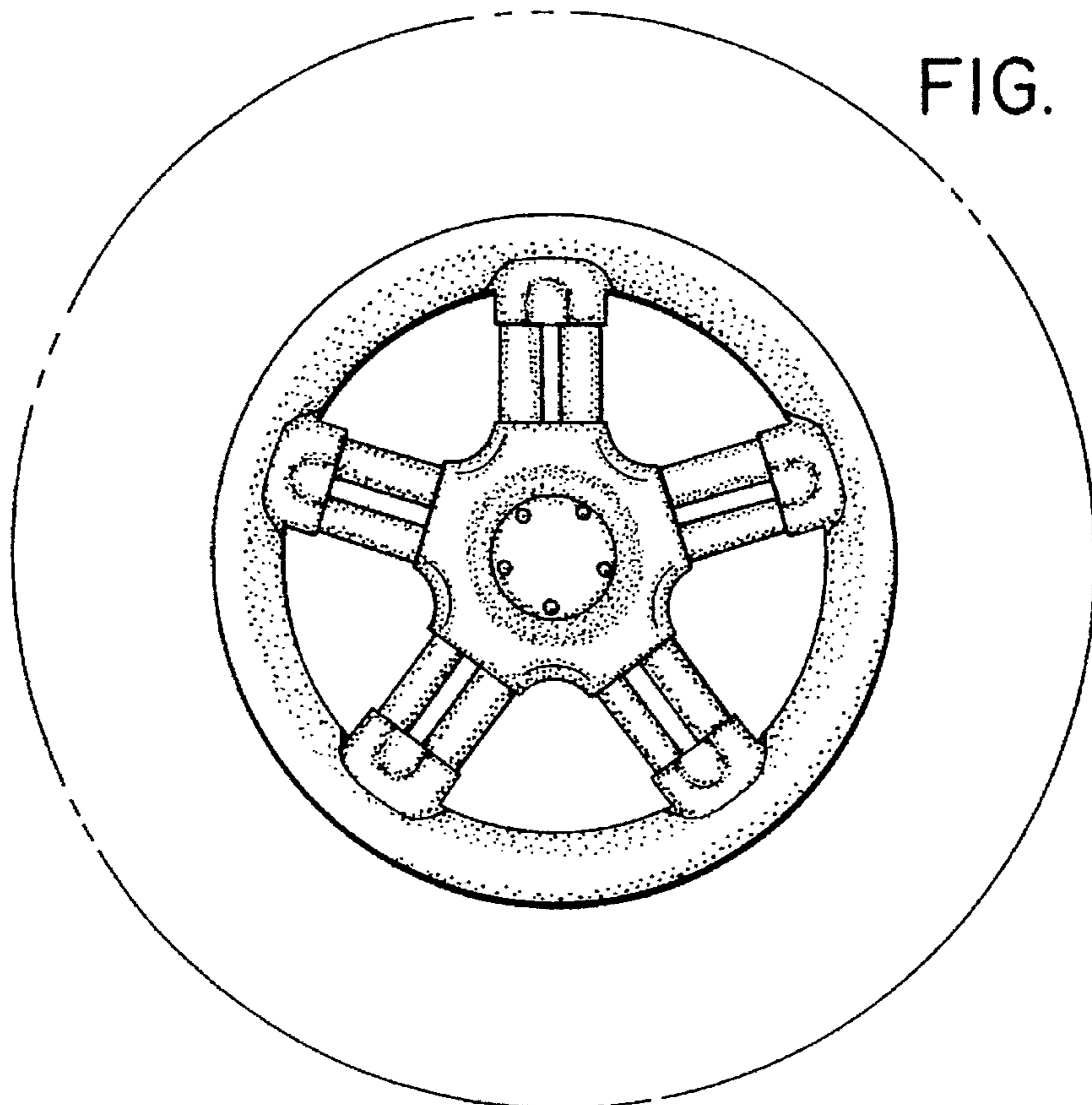

FIG. 4