



US00D381590S

# United States Patent [19]

Thoeni et al.

[11] Patent Number: **Des. 381,590**

[45] Date of Patent: **\*\*Jul. 29, 1997**

## [54] PROCESS CONTROL INSTRUMENT

[75] Inventors: **Stewart Thoeni**, Carson City; **Trevor Aland**, Reno, both of Nev.

[73] Assignee: **Elsag International N.V.**, Amsterdam, Netherlands

[\*\*] Term: **14 Years**

[21] Appl. No.: **54,193**

[22] Filed: **May 8, 1996**

[51] LOC (6) Cl. .... **10-04**

[52] U.S. Cl. .... **D10/49; D10/75; D13/164**

[58] Field of Search ..... D10/49, 50, 75; D13/164; 57/264; 355/208, 246; 364/131, 133, 138, 146, 150, 162, 164, 165, 187, 188, 189, 468, 470, 481-487, 550-582; 395/200.02

## [56] References Cited

### U.S. PATENT DOCUMENTS

D. 208,492	9/1967	Aldingen	.....	D10/49 X
D. 264,449	5/1982	Izaki	.....	D10/75 X
D. 264,825	6/1982	Izaki	.....	D10/75
D. 269,265	6/1983	Bean et al.	.....	D13/41
D. 307,708	5/1990	Moriyama et al.	.....	D13/164
5,392,223	2/1995	Caci	.....	364/146 X
5,506,767	4/1996	Naylor	.....	364/146 X

## OTHER PUBLICATIONS

Rosemount Analytical, Model pH/ORP Microprocessor Analyzer -Instruction Manual, Mar. 1995, pp. Cover to 1-5.  
Great Lakes Instruments, Inc., Model P63 pH Analyzer -Manual No. P63, Revision 1-995, pp. Cover, 29, 16 and 17.  
George Fischer -Signet -Measurement Transmitter -Instruction Manual.  
Yokogawa, Model SC200 2-Wire Conductivity Transmitter -Instruction Manual, Aug. 1991, pp. Cover, 4 and 5.

*Primary Examiner*-Antoine Duval Davis  
*Attorney, Agent, or Firm*-Michael M. Rickin

## [57] CLAIM

The ornamental design for a process control instrument, as shown and described.

## DESCRIPTION

FIG. 1 is a front, top and right side perspective view of a process control instrument showing our new design; FIG. 2 is a front elevational view thereof; FIG. 3 is a rear elevational view thereof; FIG. 4 is a right side elevational view thereof; FIG. 5 is a left side elevational view thereof; and, FIG. 6 is a bottom plan view thereof; FIG. 7 is a top plan view thereof; and, FIG. 8 is a partial view of the bottom thereof showing another pattern for the holes therein, all other portions of this view are identical to those shown in FIG. 6.

**1 Claim, 4 Drawing Sheets**

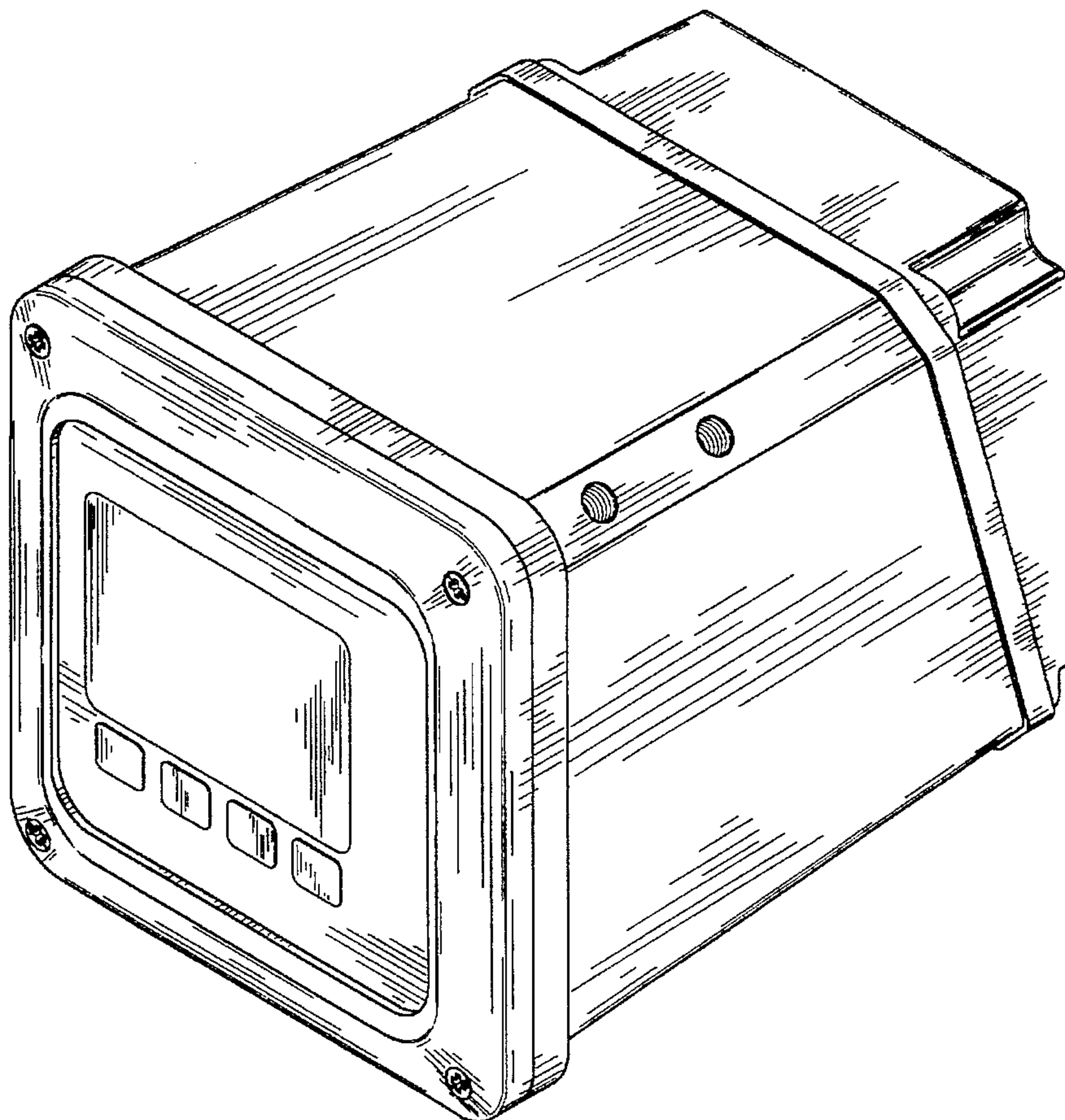

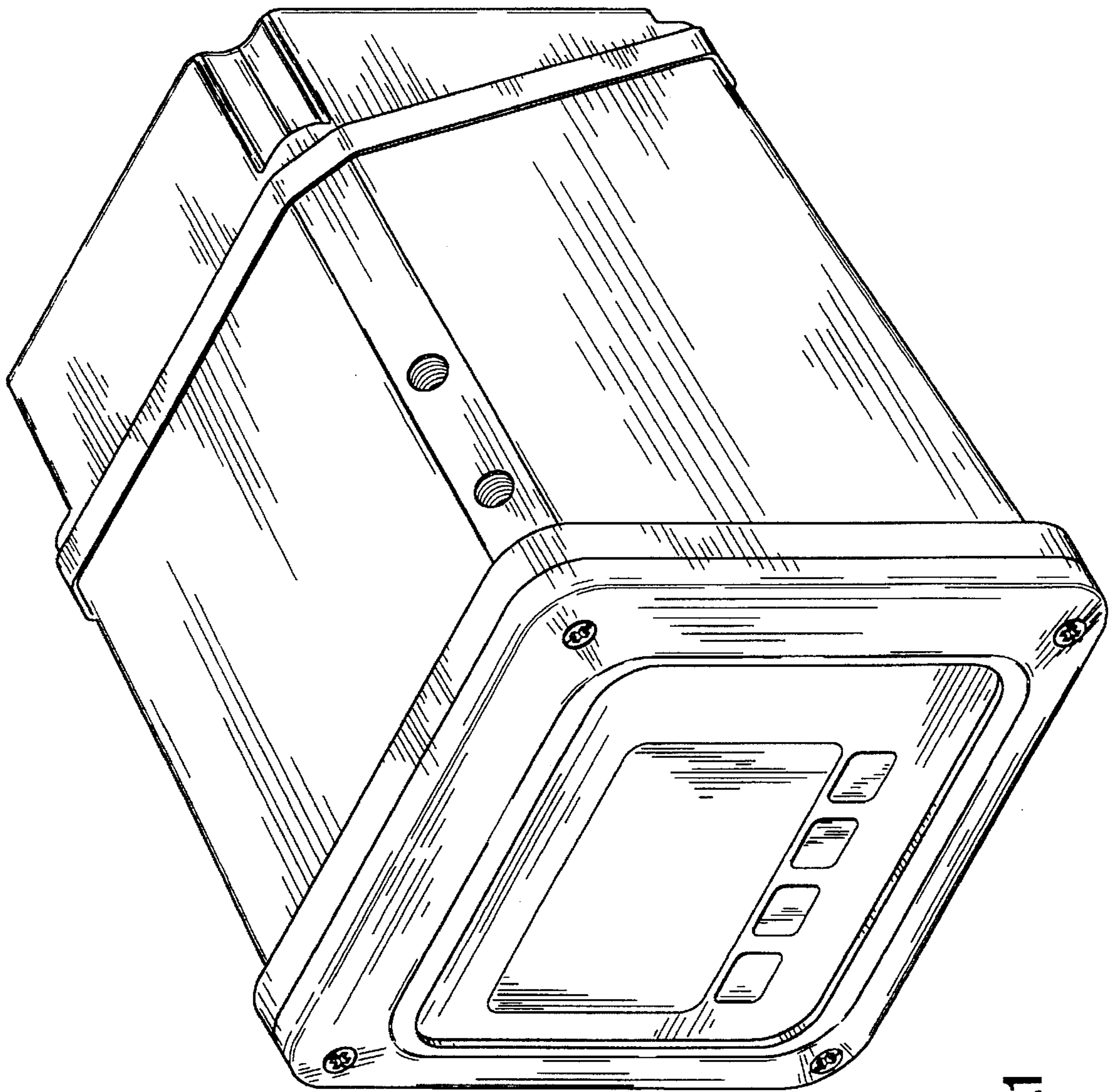

Fig.1



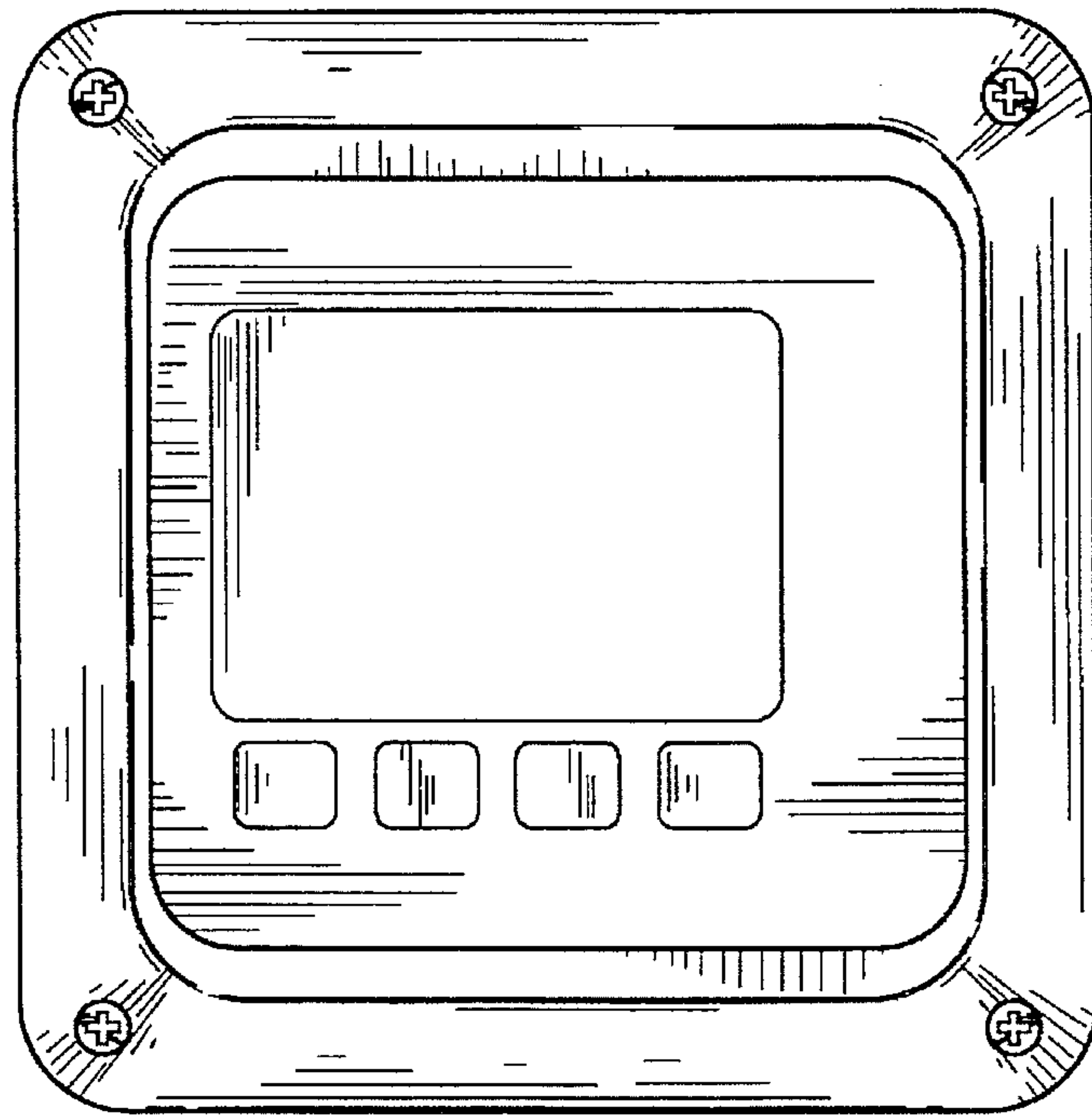

Fig.2

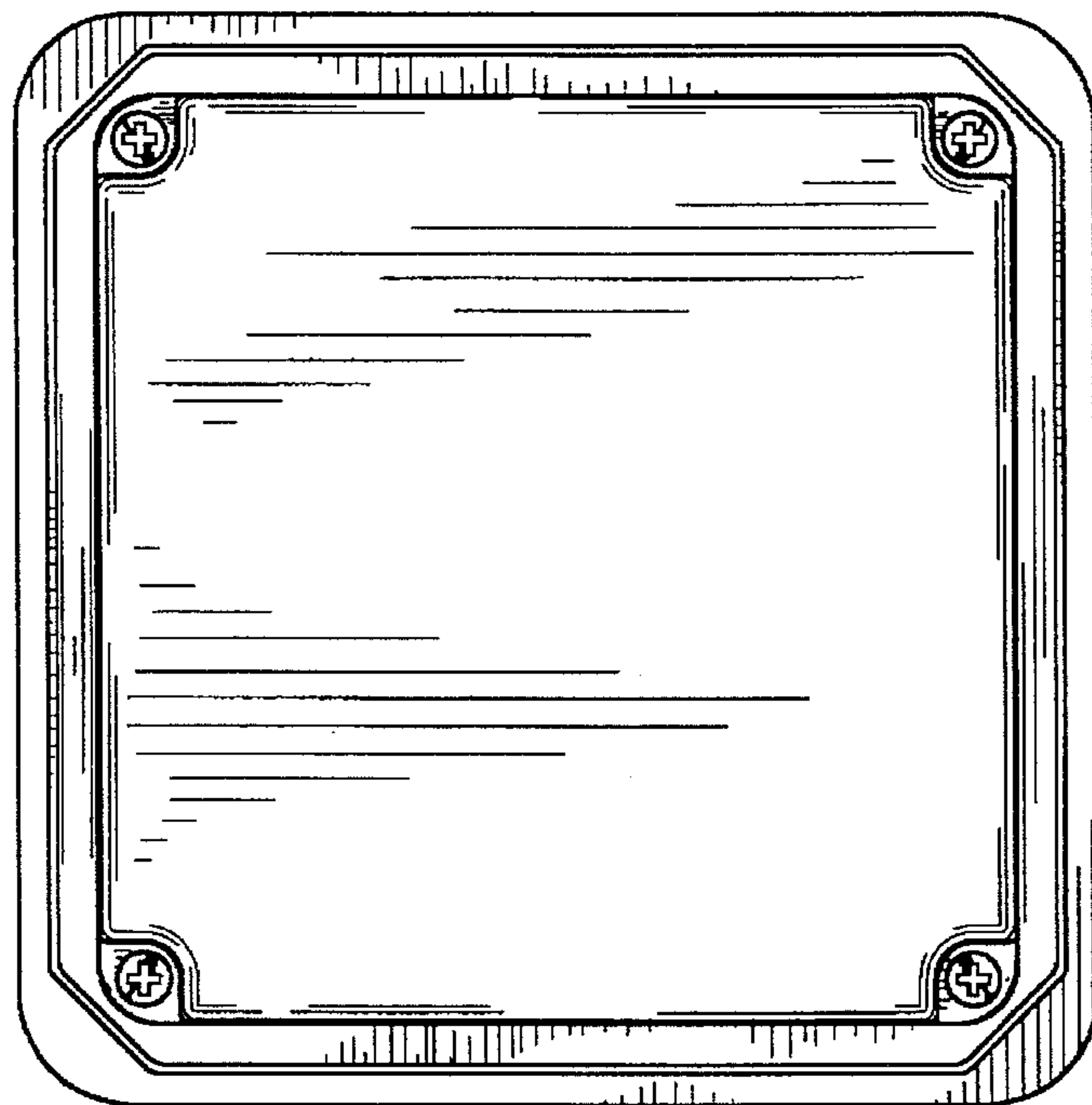

Fig.3

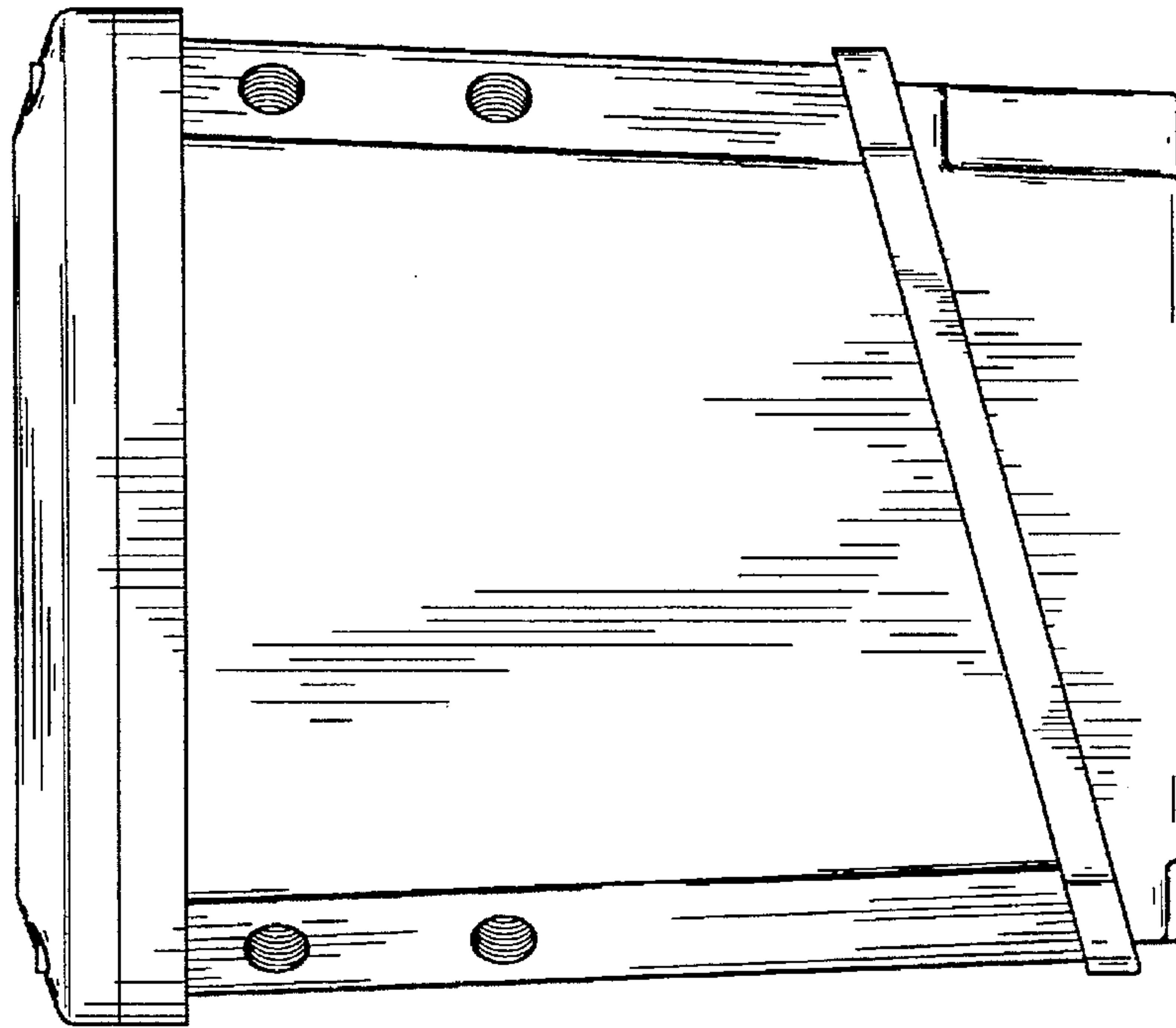

Fig.4

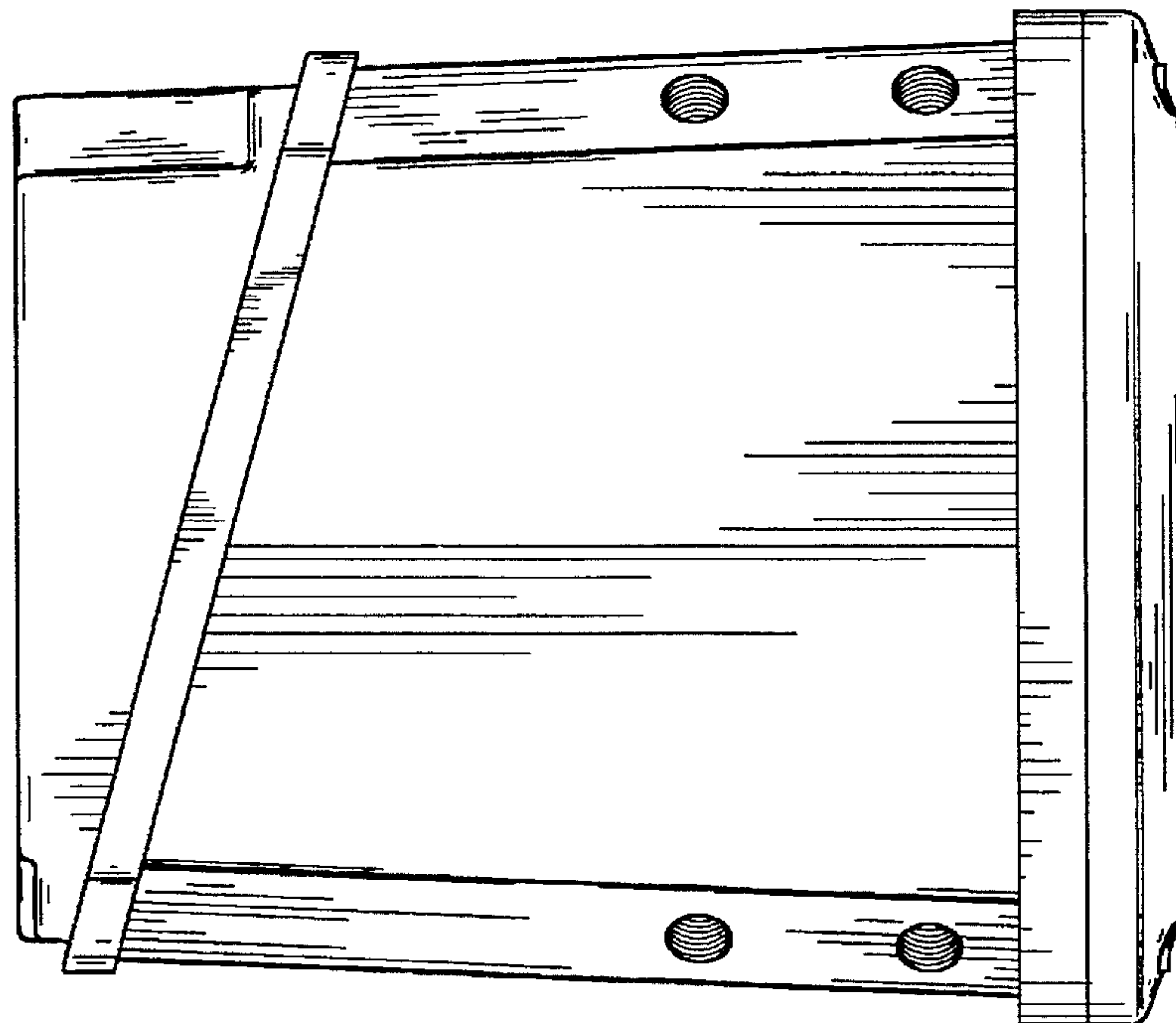

Fig.5

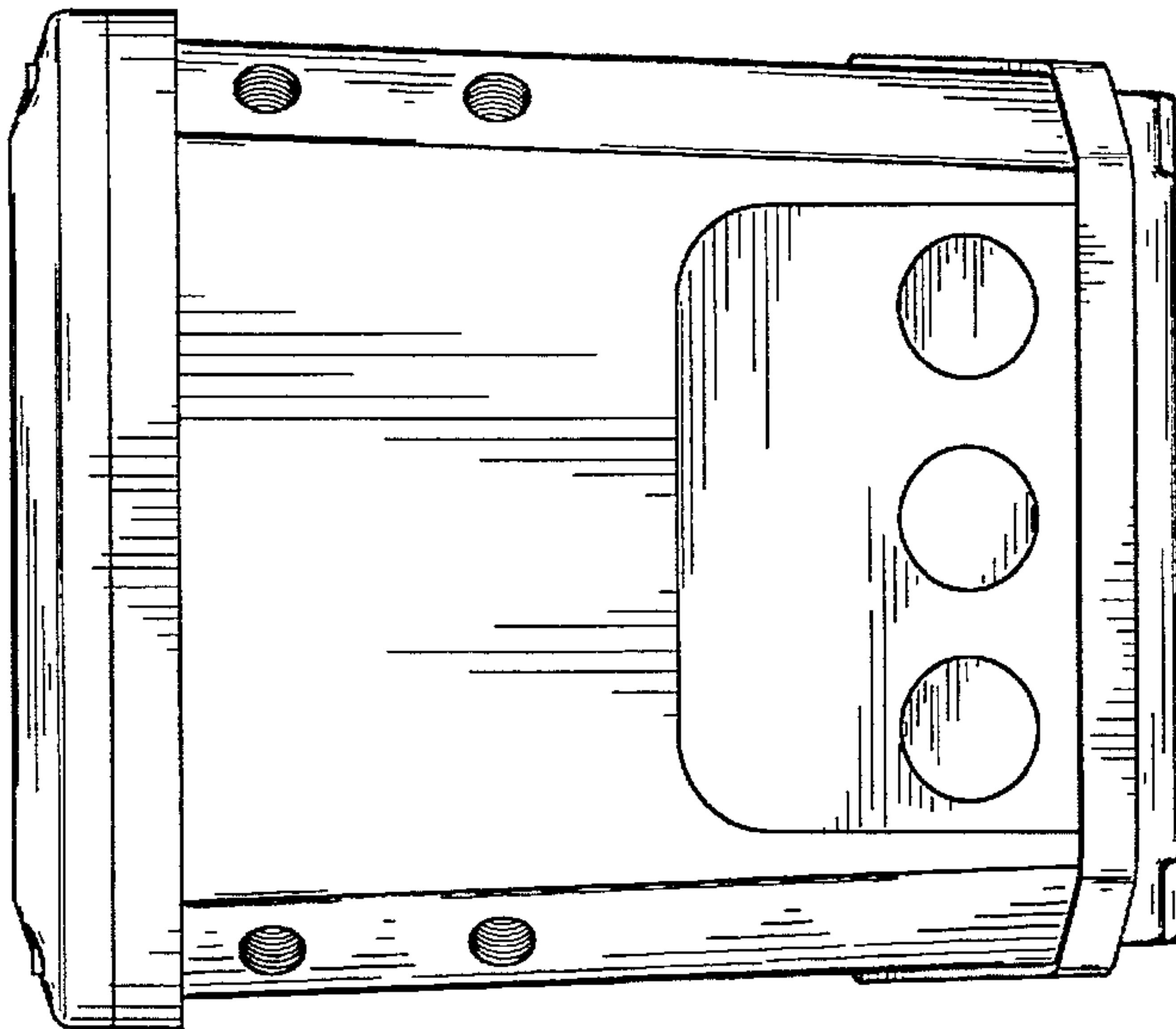

Fig.6

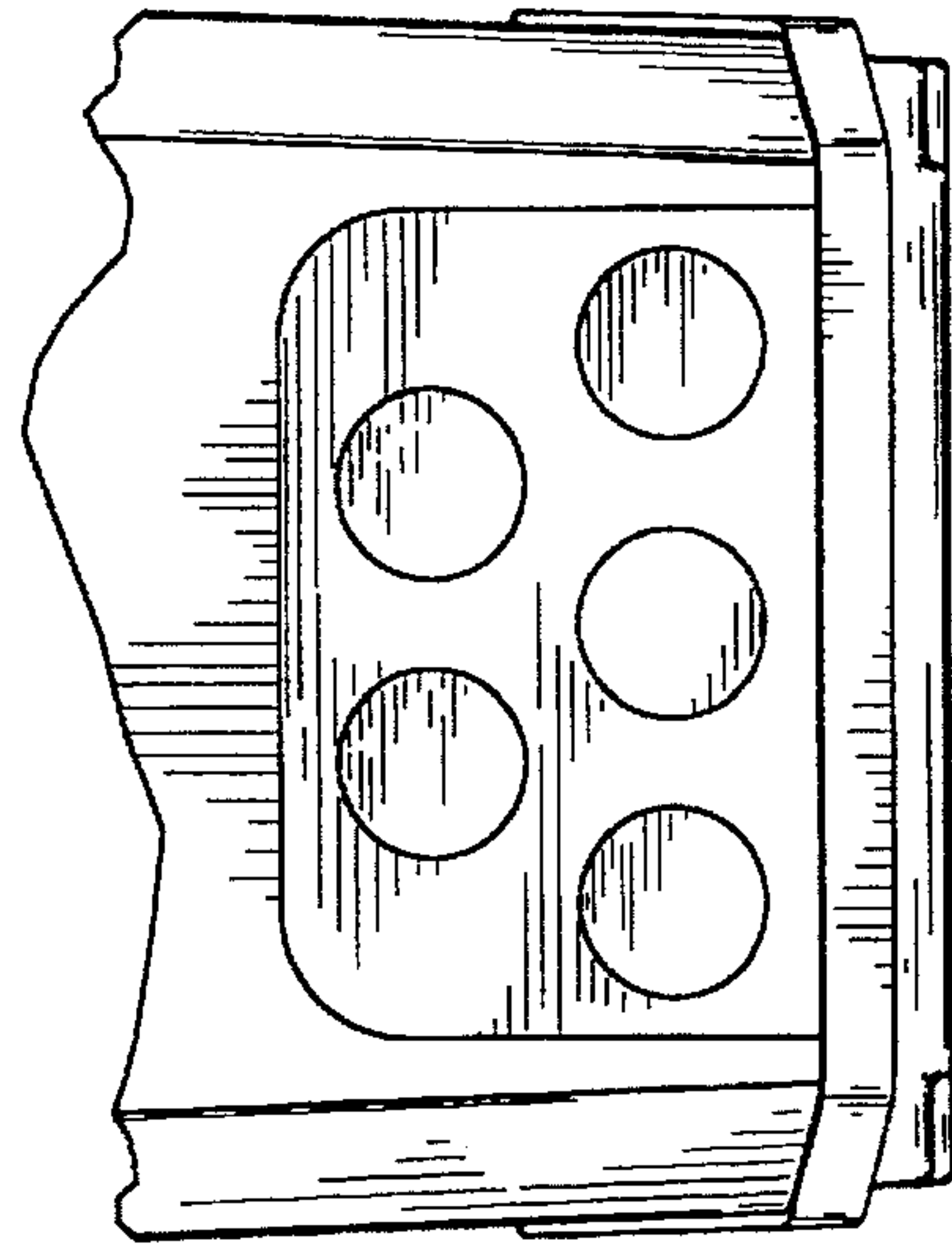

Fig.8

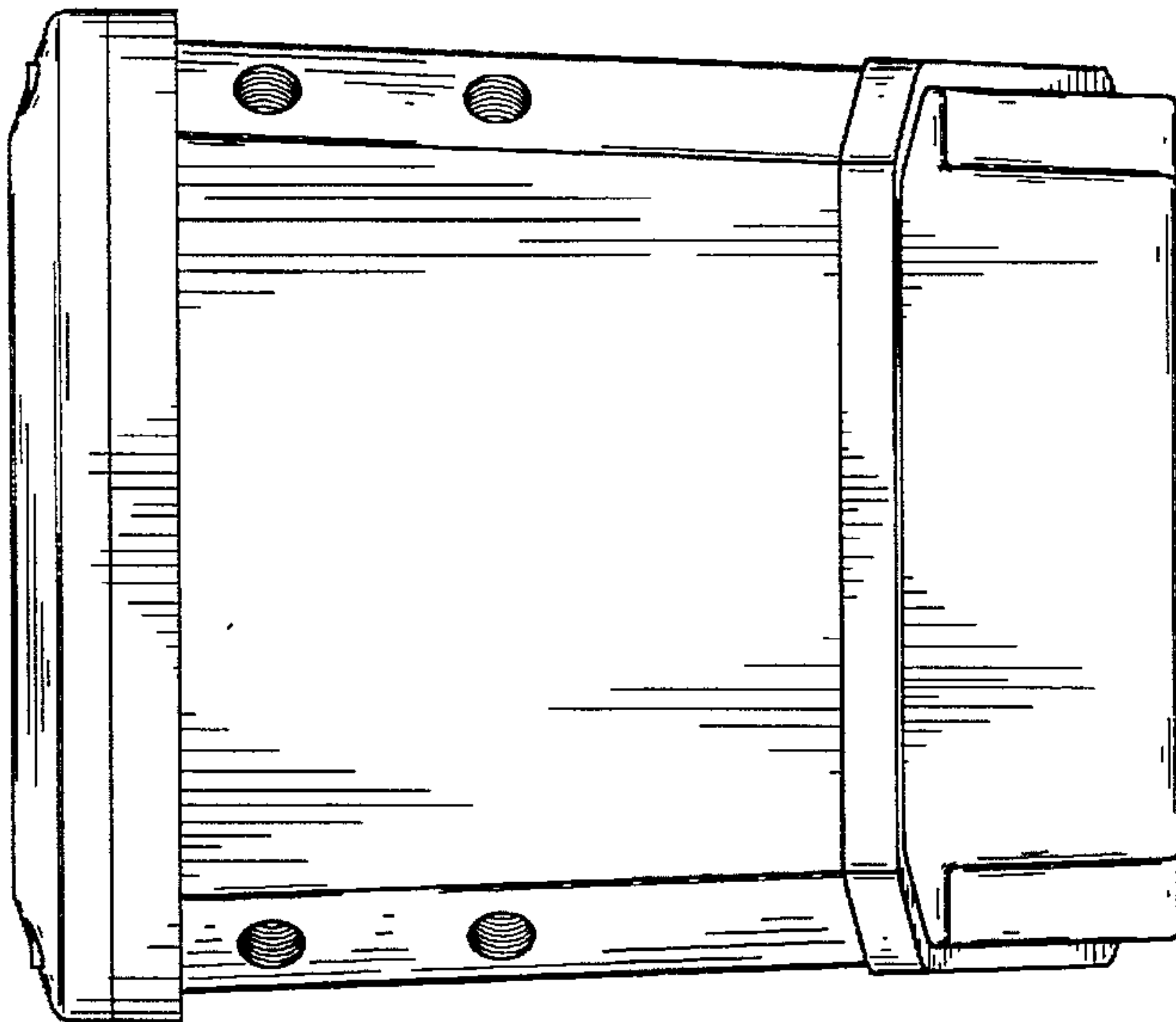

Fig.7