



US00D381536S

**United States Patent** [19]  
**Kane**

[11] **Patent Number:** **Des. 381,536**  
[45] **Date of Patent:** **\*\*Jul. 29, 1997**

[54] **MODULAR SEATING UNIT**

[75] **Inventor:** **Brian J. Kane**, San Francisco, Calif.

[73] **Assignee:** **Landscape Forms, Inc.**, Kalamazoo, Mich.

[\*\*] **Term:** **14 Years**

[21] **Appl. No.:** **51,295**

[22] **Filed:** **Mar. 1, 1996**

[51] **LOC (6) Cl.** ..... **06-06**

[52] **U.S. Cl.** ..... **D6/500; D6/370**

[58] **Field of Search** ..... **D6/334, 335, 349, D6/355, 370, 376, 381, 500, 501, 502; 297/452.63**

[56] **References Cited**

**U.S. PATENT DOCUMENTS**

D. 94,089	12/1934	Lucas	.....	D6/370	X
D. 215,430	9/1969	Suzuki	.....	D6/370	X
D. 216,115	11/1969	Suzuki	.....	D6/370	
D. 229,591	12/1973	Trail	.....	D6/370	
235,437	12/1880	Hopkins	.....	297/452.63	
D. 304,253	10/1989	Skalka	.....	D34/6	

D. 310,636	9/1990	Skalka	.....	D6/500
D. 344,200	2/1994	Schwartz	.....	D6/500
D. 366,775	2/1996	Kane	.....	D6/370
3,511,536	5/1970	Suzuki	.....	297/452.63

**OTHER PUBLICATIONS**

Landscape Forms, Inc. 1995, Buyline 2978, pp. 1-20.  
Victoria Stanley Inc., Buyline 1157, pp. 1-3 undated.

*Primary Examiner*—Gary D. Watson  
*Attorney, Agent, or Firm*—Heslin & Rothenberg, P.C.

[57] **CLAIM**

The ornamental design for a modular seating unit, as shown and described.

**DESCRIPTION**

FIG. 1 is a front isometric view of a modular seating unit showing my new design;  
FIG. 2 is a left side elevational view thereof;  
FIG. 3 is a right side elevational view thereof;  
FIG. 4 is a front elevational view thereof;  
FIG. 5 is a back elevational view thereof;  
FIG. 6 is a top plan view thereof; and,  
FIG. 7 is a bottom plan view thereof.

The broken lines shown in the drawings are for environmental purposes and form no part of the claimed design.

**1 Claim, 6 Drawing Sheets**

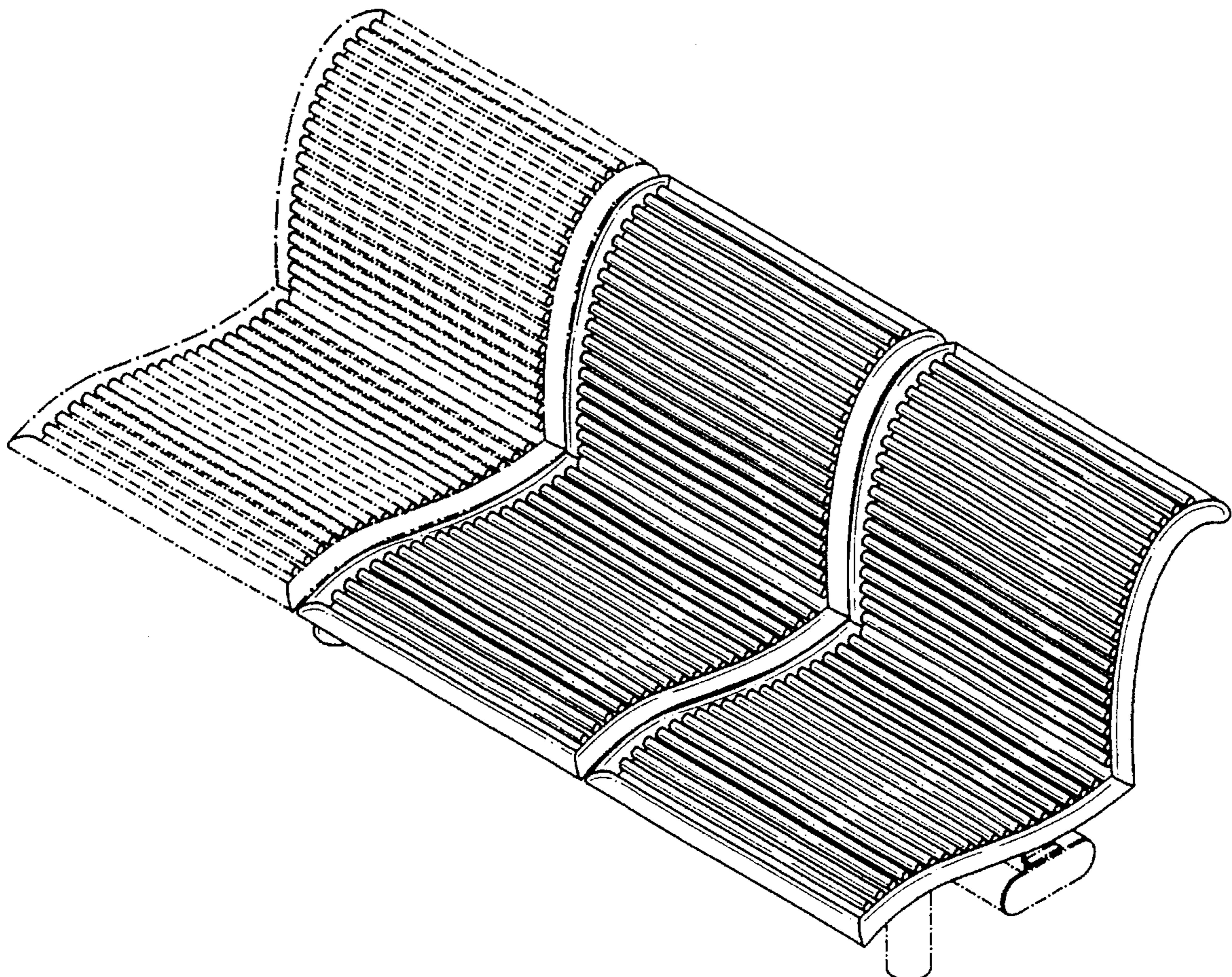

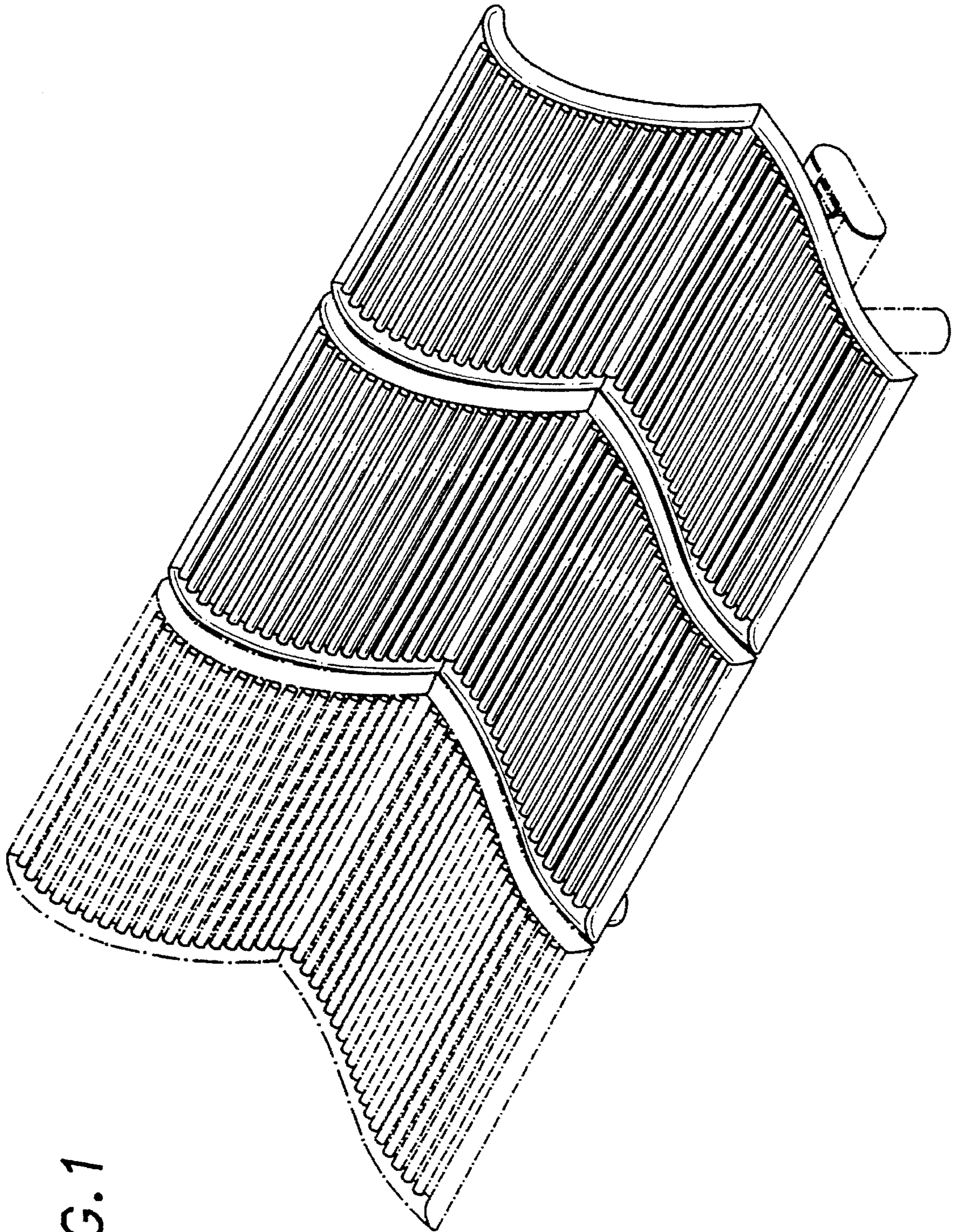

FIG. 1

FIG. 3

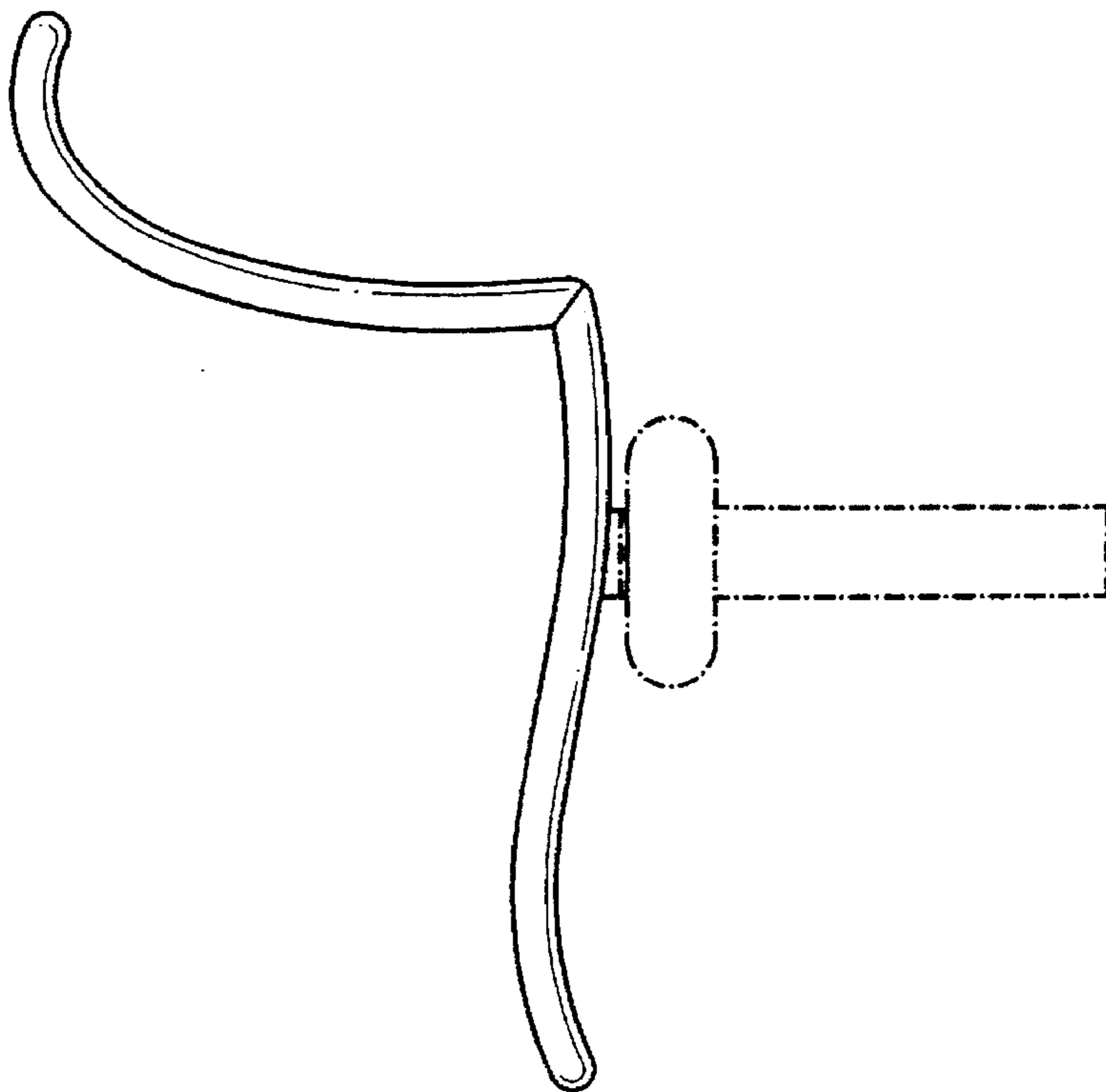

FIG. 2

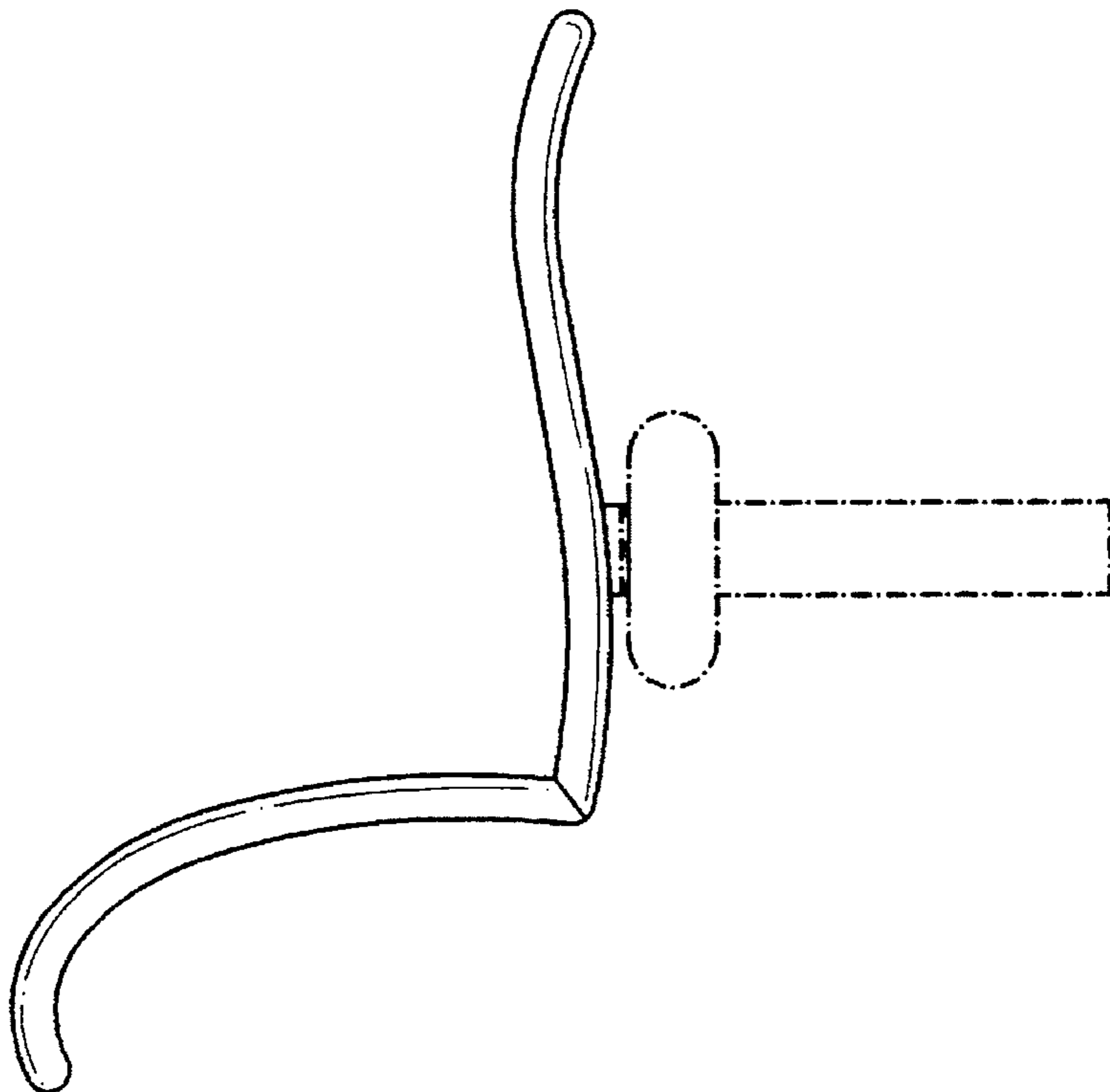

FIG. 4

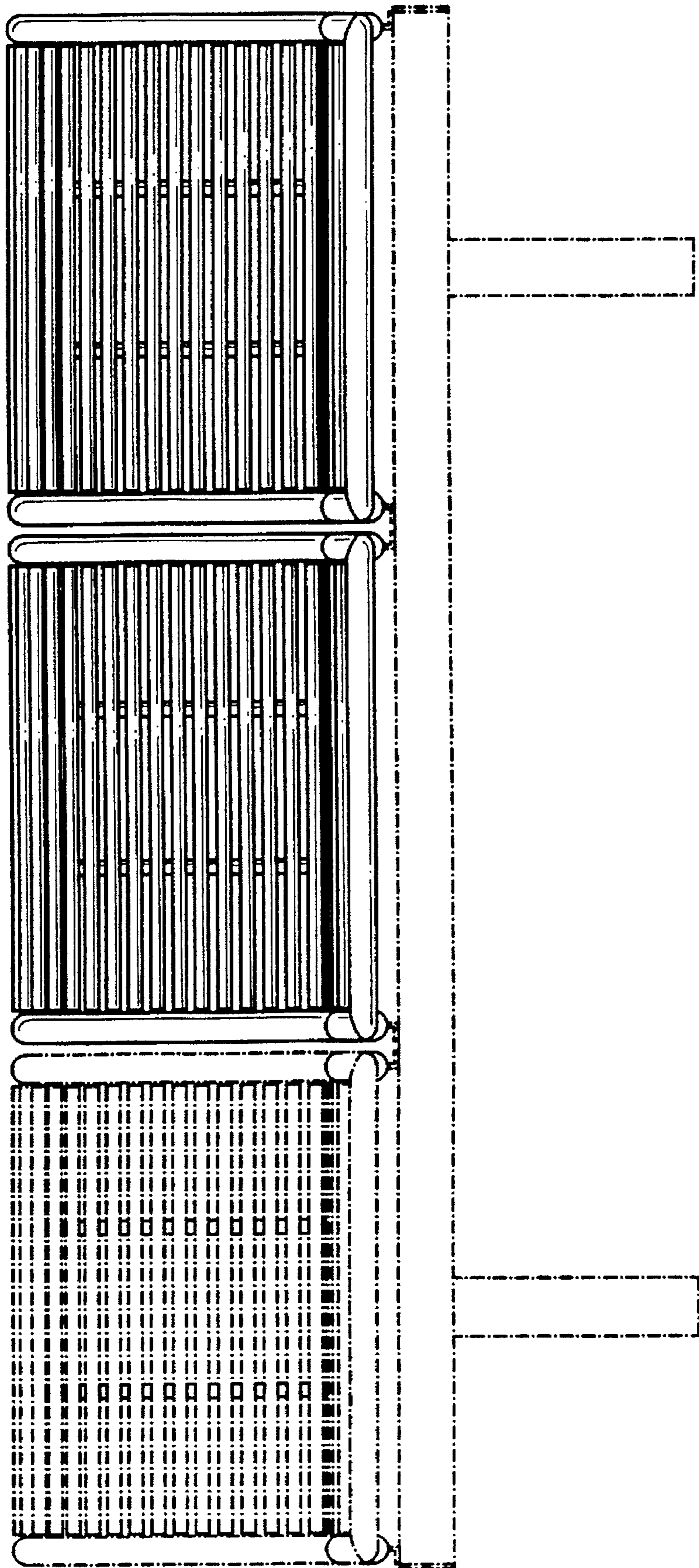
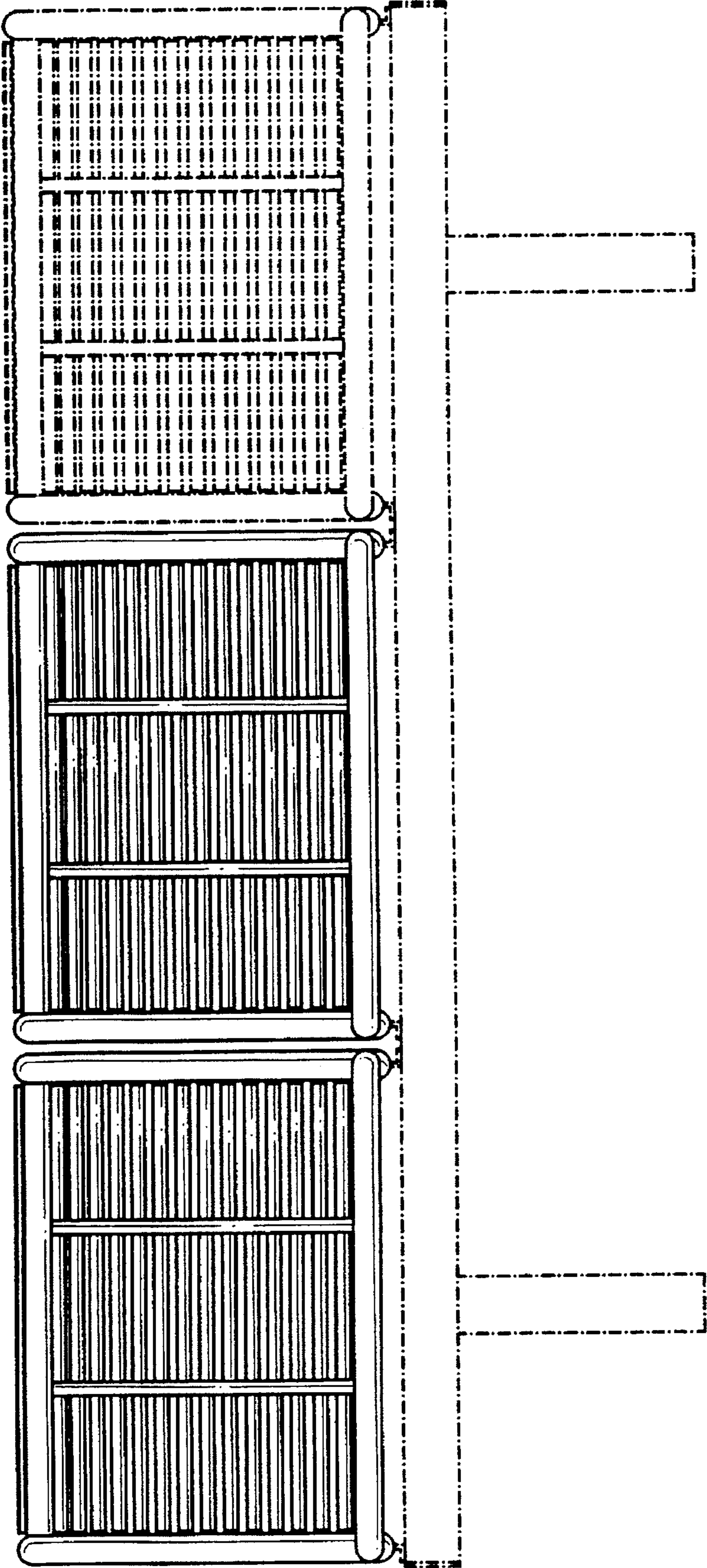

FIG. 5



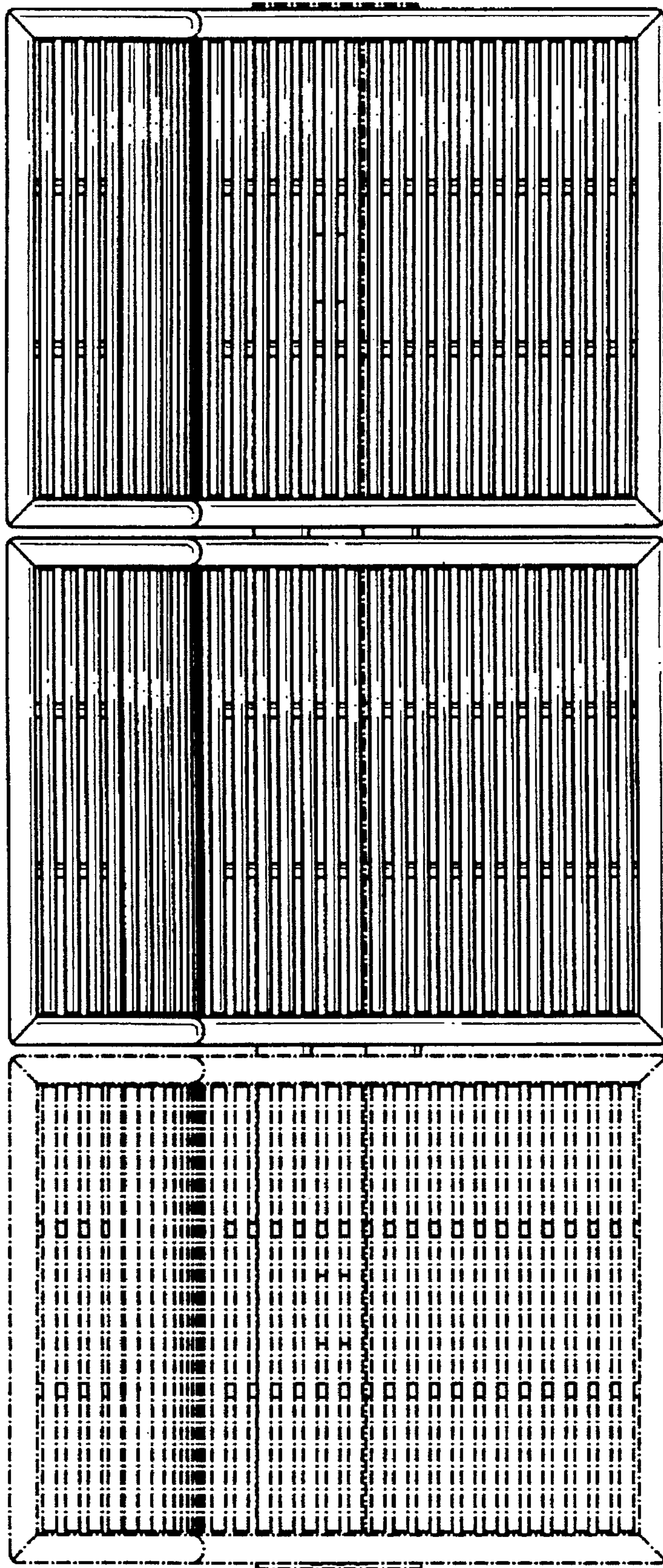

FIG. 6

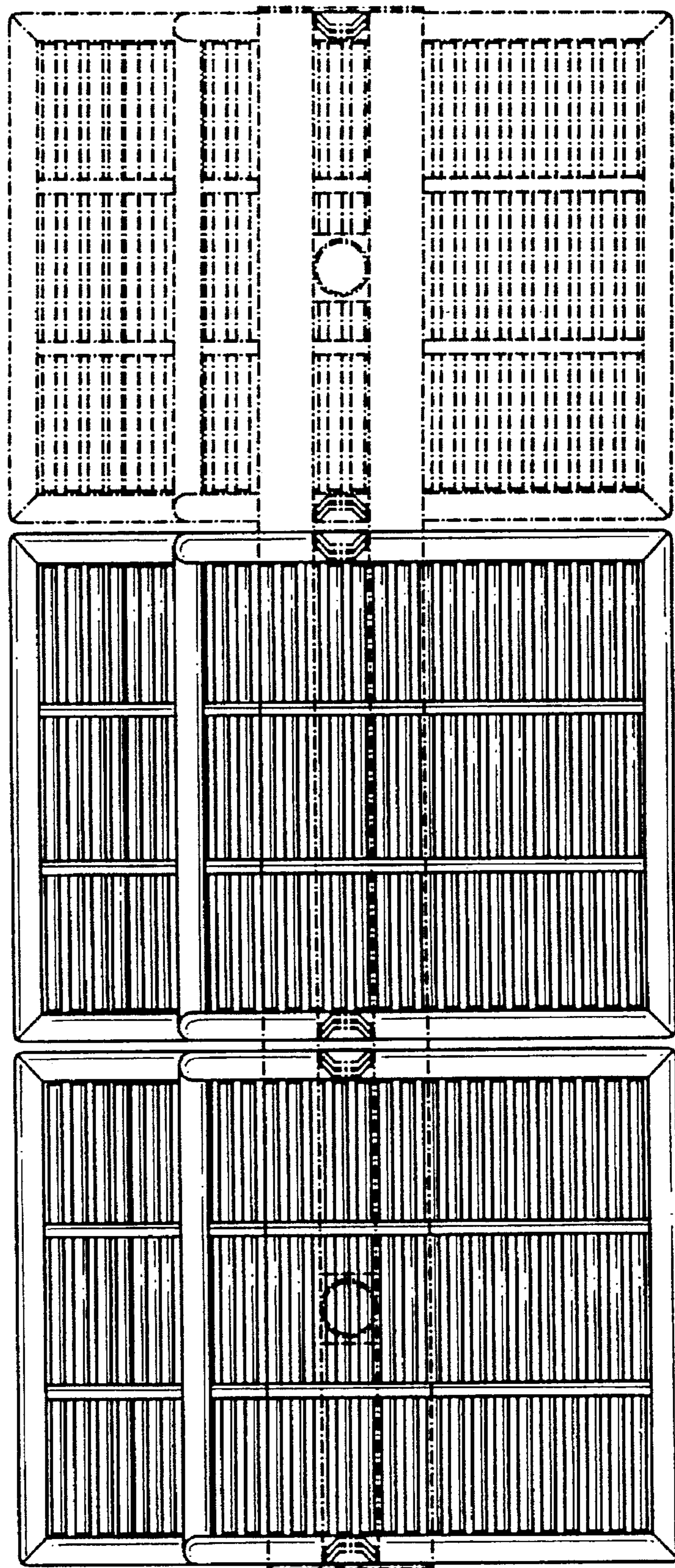

FIG. 7