



US00D381311S

# United States Patent [19]

[11] Patent Number: **Des. 381,311**

Prasatek et al.

[45] Date of Patent: **\*\*Jul. 22, 1997**

## [54] VEHICLE TOP WITH LUGGAGE CARRIER SIDERAILS

[75] Inventors: **Craig R. Prasatek**, Rochester Hills; **Gregory L. Eilers**, Royal Oak; **John S. MacKay**, Capac, all of Mich.; **David Esparza**, Huntington Beach; **Junji Tanabe**, Torrance, both of Calif.

[73] Assignees: **MascoTech, Inc.**, Taylor, Mich.; **Honda Giken Kogyo Kabushiki Kaisha**, Tokyo, Japan

[\*\*] Term: **14 Years**

[21] Appl. No.: **35,851**

[22] Filed: **Mar. 8, 1995**

[51] LOC (6) Cl. .... **12-16**

[52] U.S. Cl. .... **D12/412**

[58] Field of Search ..... D12/406, 412, D12/414; 224/42.1, 42.2, 309, 316, 317, 322-329; 296/37.7

## [56] References Cited

### U.S. PATENT DOCUMENTS

- Re. 26,539 3/1969 Bott .
- D. 250,461 12/1978 Bott .
- D. 250,464 12/1978 Bott .
- D. 264,203 5/1982 Bott .
- D. 272,817 2/1984 Mareydt .
- D. 314,541 2/1991 Bott .
- D. 318,639 7/1991 Santoro et al. .
- D. 333,808 3/1993 Cucheran .
- D. 334,162 3/1993 Cucheran et al. .... D12/412
- D. 334,373 3/1993 Cucheran .
- D. 359,943 7/1995 Cucheran et al. .... D12/414
- 3,253,755 5/1966 Bott .
- 3,623,642 11/1971 Stephen .
- 4,055,284 10/1977 Bott .
- 4,165,827 8/1979 Bott .
- 5,007,570 4/1991 Himmel ..... 224/326 X
- 5,014,893 5/1991 Morley et al. .... 224/326 X
- 5,133,490 7/1992 Cucheran ..... 224/326 X
- 5,174,484 12/1992 Bott ..... 224/326 X
- 5,385,285 1/1995 Cucheran et al. .... 224/321
- 5,402,925 4/1995 Arvidsson et al. .... 224/324 X
- 5,411,196 5/1995 Lee, Jr. et al. .... 224/321

## FOREIGN PATENT DOCUMENTS

- 1061457 8/1952 France .
- 3814799 11/1988 Germany ..... 224/325
- 453688 7/1949 Italy .

## OTHER PUBLICATIONS

- Autocar, Oct. 19, 1962, p. 64.
- Autocar, Nov. 9, 1962, p. 42 and p. 843.
- Autocar, Mar. 1, 1963, p. 365.
- Autocar, May. 6, 1966, p. 29.
- Car and Driver, Sep. 1966, pp. 56-57.
- Automotive Engineering, Jan. 1995, p. 5.
- Automotive Engineering, Jan. 1995, p. 100.
- Automotive Engineering, Jan. 1995, p. 69.
- Automotive Engineering, Jan. 1995, p. 80.
- Honda Accord/Civic, Accessories 1992, pp. 8-9.
- Rocket Rack, drawing, Aug. 31, 1988.

*Primary Examiner*—James Gandy  
*Assistant Examiner*—Cathron B. Matta  
*Attorney, Agent, or Firm*—Leon E. Redman

## [57] CLAIM

The ornamental design for a vehicle top with luggage carrier siderails, as shown and described.

## DESCRIPTION

FIG. 1 is a perspective view of a vehicle top with luggage carrier siderails showing our new design; FIG. 2 is an end elevational view of the forward end thereof; FIG. 3 is an end elevational view of the rear end thereof; FIG. 4 is a right side elevational view thereof, the left side being a mirror image of the right side; FIG. 5 is a top plan view thereof; FIG. 6 is an enlarged cross sectional view of the siderail thereof taken along the lines 6-6 of FIG. 4; and FIG. 7 is a perspective view of the inner side of the left siderail, the right siderail being a mirror image of the left siderail.

The broken lines are for illustrative purposes only and form no part of the claimed design.

In FIGS. 6 and 7, the siderail is shown independently of the vehicle top for ease of illustration.

**1 Claim, 4 Drawing Sheets**

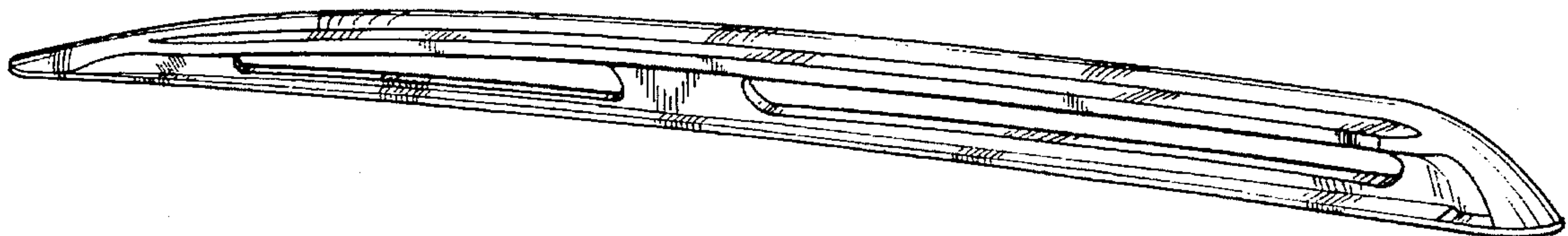

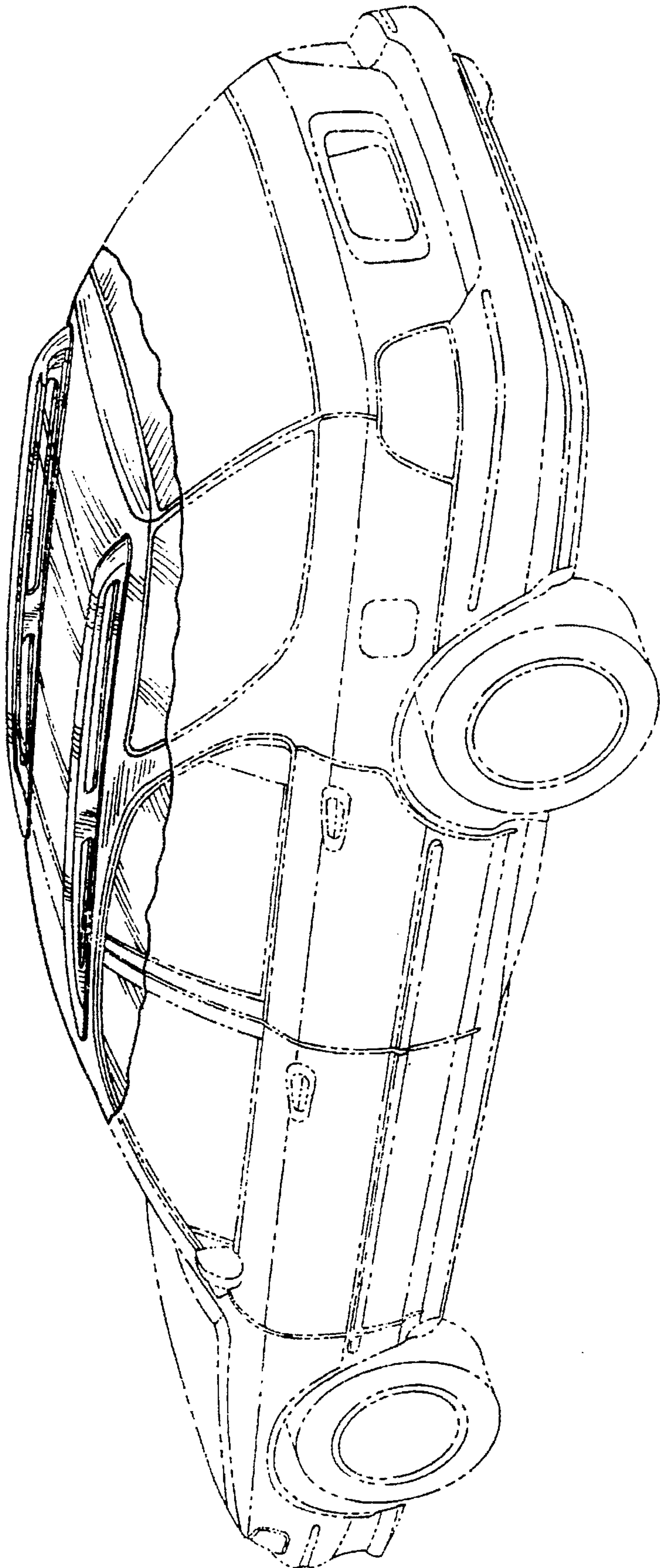

Fig - 1

Fig - 2

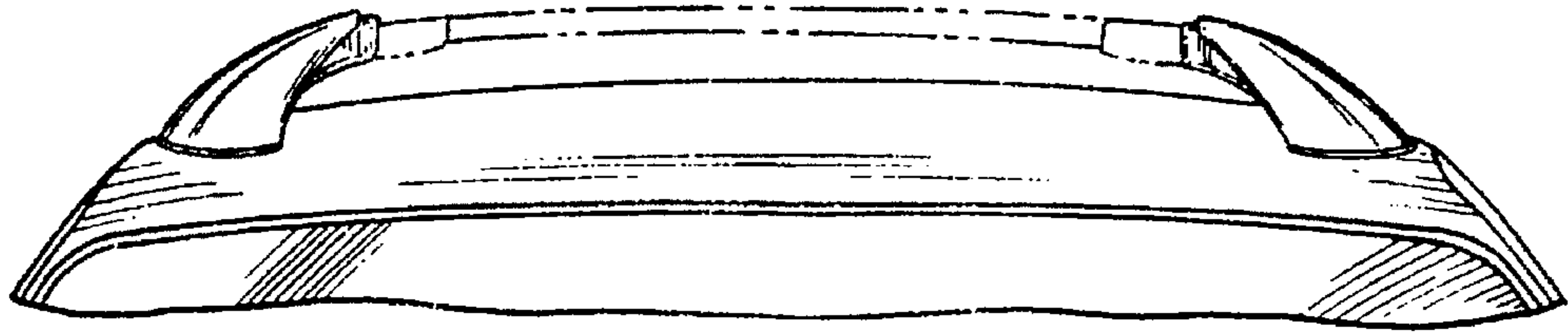

Fig - 3

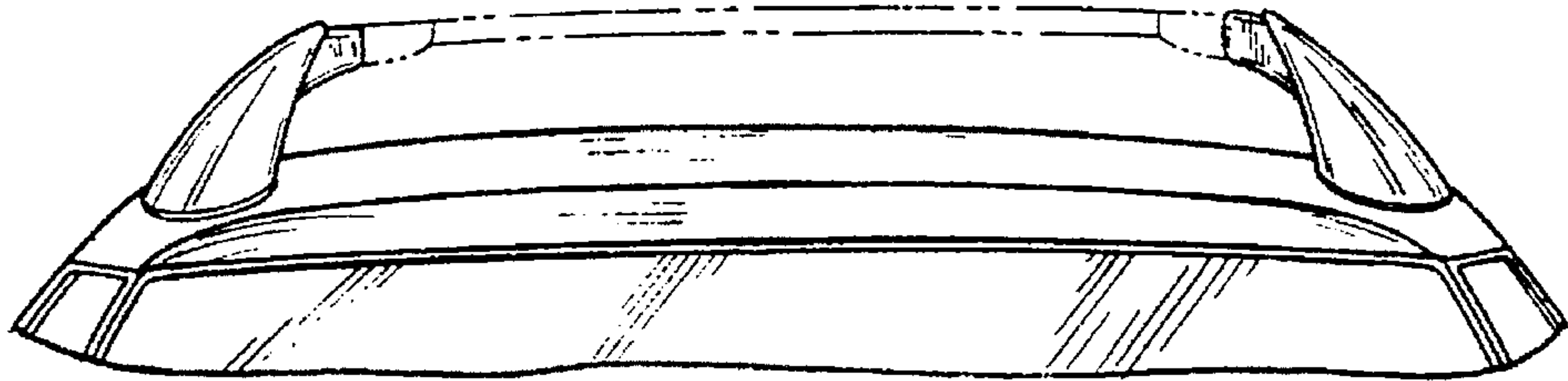
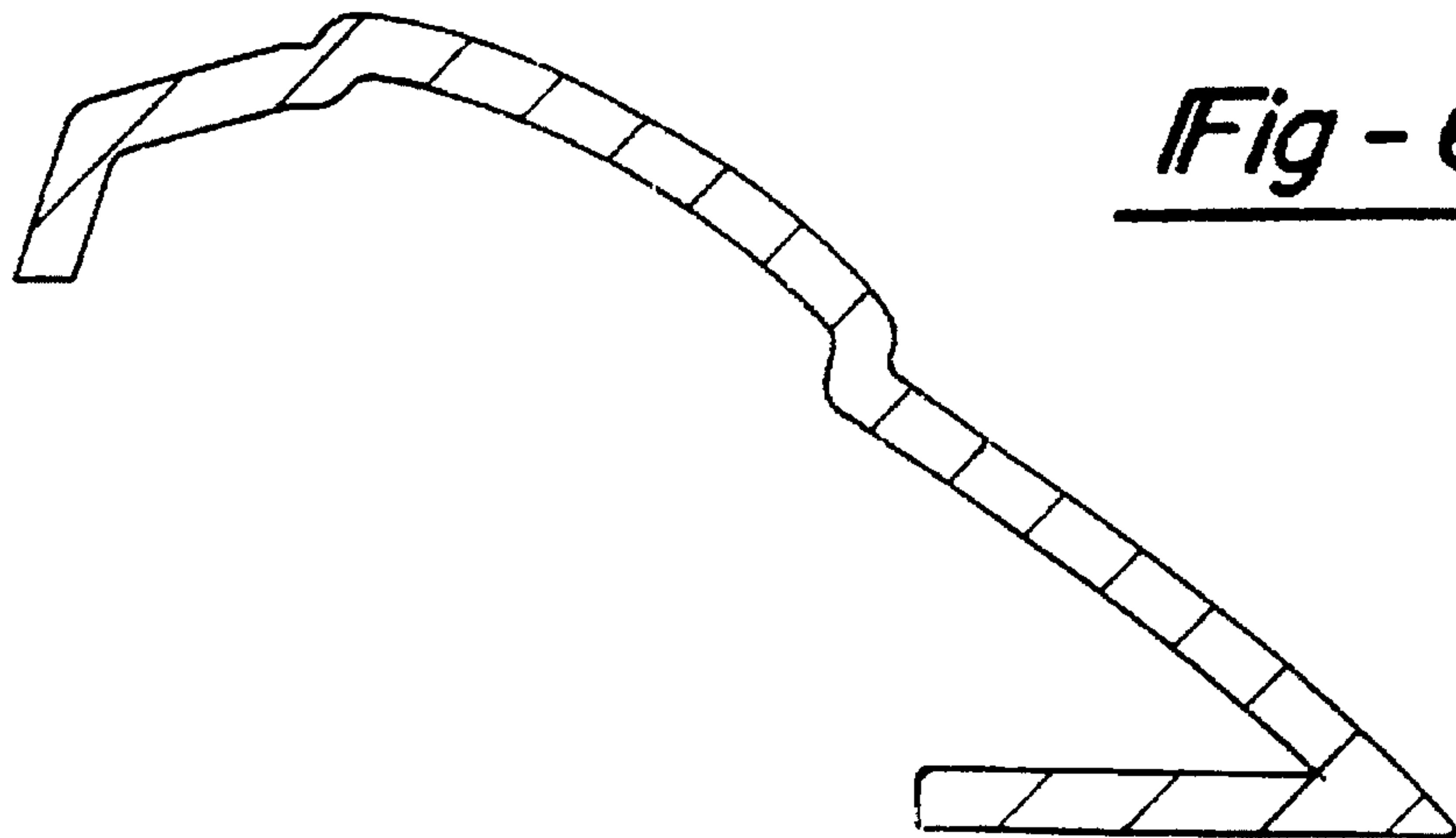

Fig - 6





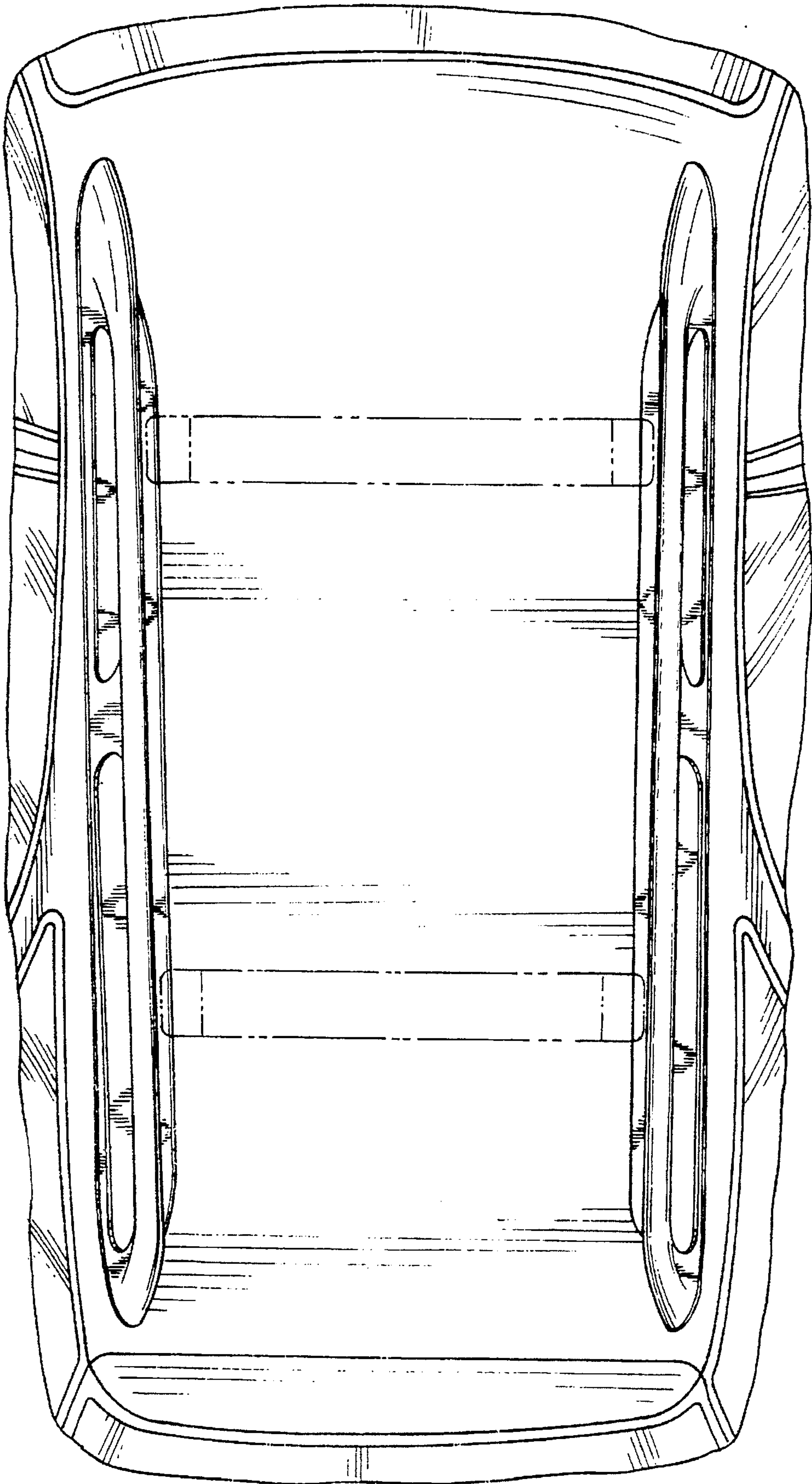

Fig - 5

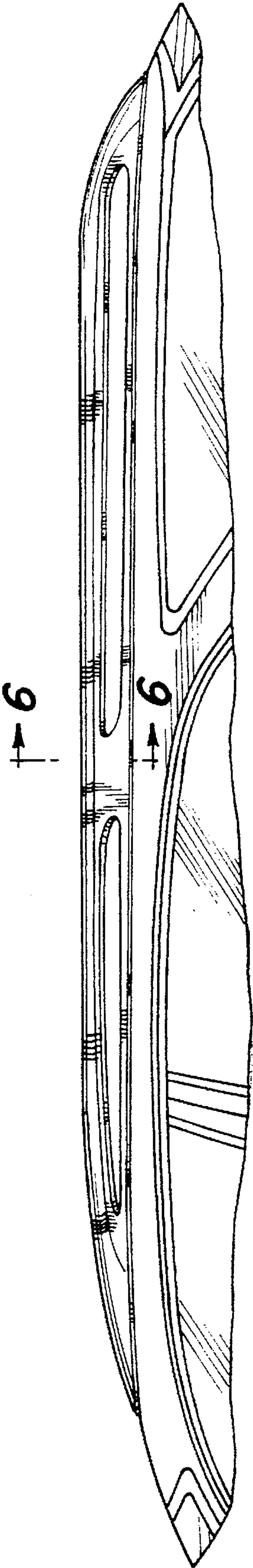

Fig - 4

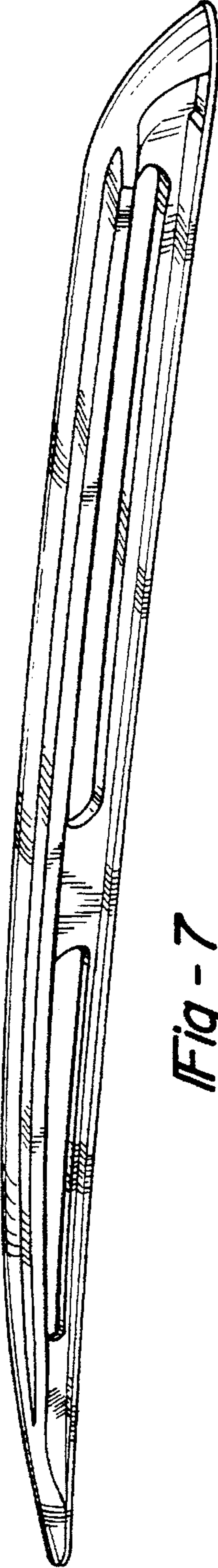

Fig - 7