



US00D381296S

# United States Patent [19]

Kurke et al.

[11] Patent Number: **Des. 381,296**

[45] Date of Patent: **\*\*Jul. 22, 1997**

[54] **BICYCLE STEM**

[76] Inventors: **Martin L. Kurke; Charles R. Kurke**, both of 121 Penn St., El Segundo, Calif. 90245; **Robert L. Morales**, 11577 Slater Ave., Unit K, Fountain Valley, Calif. 92708

[\*\*] Term: **14 Years**

[21] Appl. No.: **49,038**

[22] Filed: **May 2, 1996**

[51] LOC (6) Cl. .... **12-11**

[52] U.S. Cl. .... **D12/118**

[58] Field of Search ..... D12/118; 74/551.1-551.3; 280/279

[56] **References Cited**

**U.S. PATENT DOCUMENTS**

D. 253,589	12/1979	Horton	.....	D12/118
D. 306,418	3/1990	McMurtrey	.....	D12/118
D. 341,801	11/1993	McCornack et al.	.....	D12/118
4,939,950	7/1990	Gerven	.....	74/551.1
5,199,322	4/1993	Wee	.....	74/551.1
5,241,881	9/1993	Chen	.....	74/551.2

*Primary Examiner*—Melody N. Brown  
*Attorney, Agent, or Firm*—Erik M. Arnhem

[57] **CLAIM**

The ornamental design for a bicycle stem, as shown and described.

**DESCRIPTION**

FIG. 1 is a perspective view of a bicycle stem;  
 FIG. 2 is a top plan view thereof;  
 FIG. 3 is a bottom plan view thereof;  
 FIG. 4 is a right side elevational view thereof;  
 FIG. 5 is a left side elevational view thereof;  
 FIG. 6 is a front elevational view thereof;  
 FIG. 7 is a rear elevational view thereof;  
 FIG. 8 is a fragmentary perspective view thereof, with its detachable part removed;  
 FIG. 9 is an opposite fragmentary perspective view of FIG. 8;  
 FIG. 10 is a front elevational view of the removed detachable part in FIGS. 8 and 9;  
 FIG. 11 is a side elevational view of FIG. 10;  
 FIG. 12 is a top plan view of FIG. 10; and  
 FIG. 13 is a bottom plan view of FIG. 10.

**1 Claim, 3 Drawing Sheets**

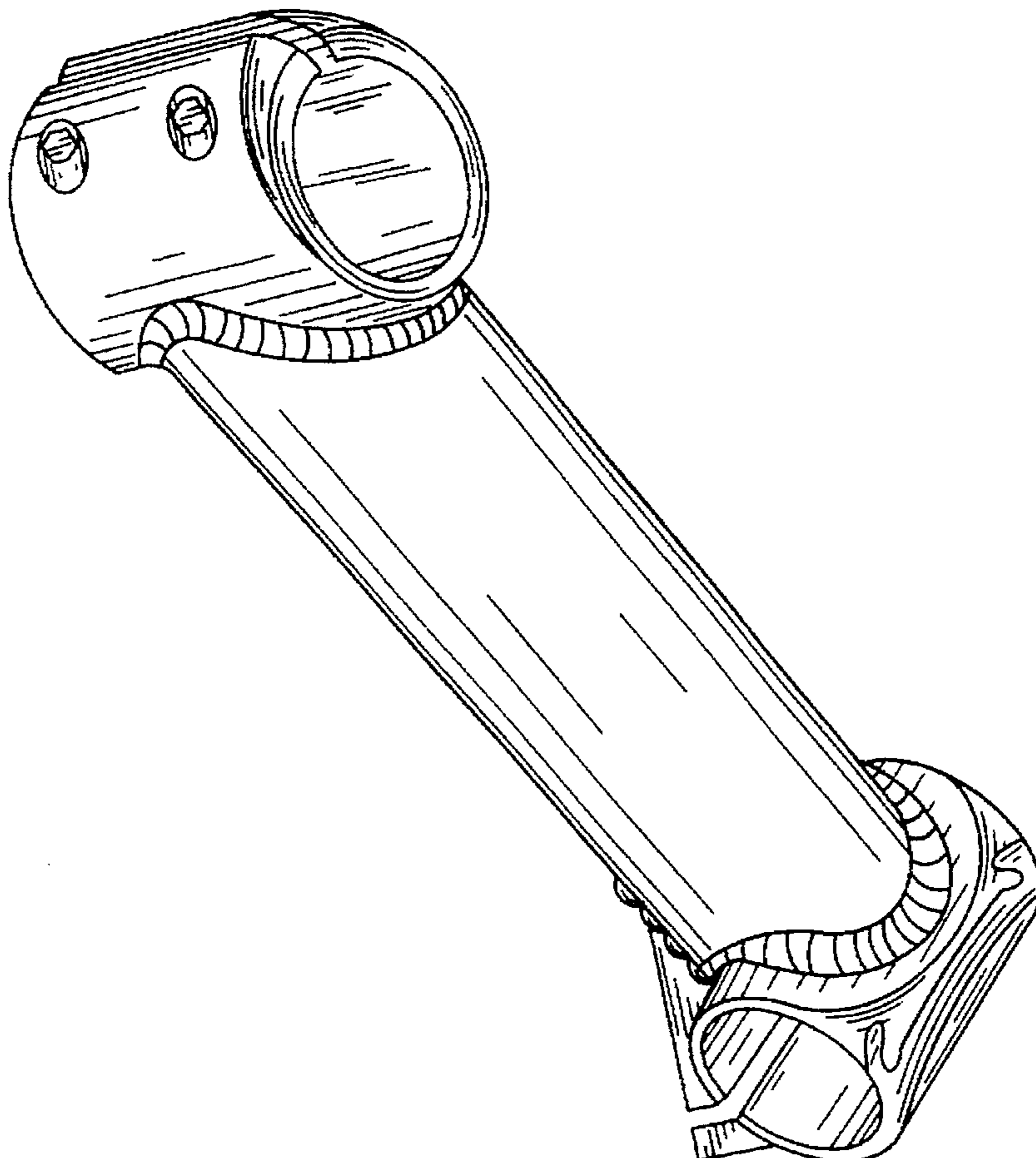

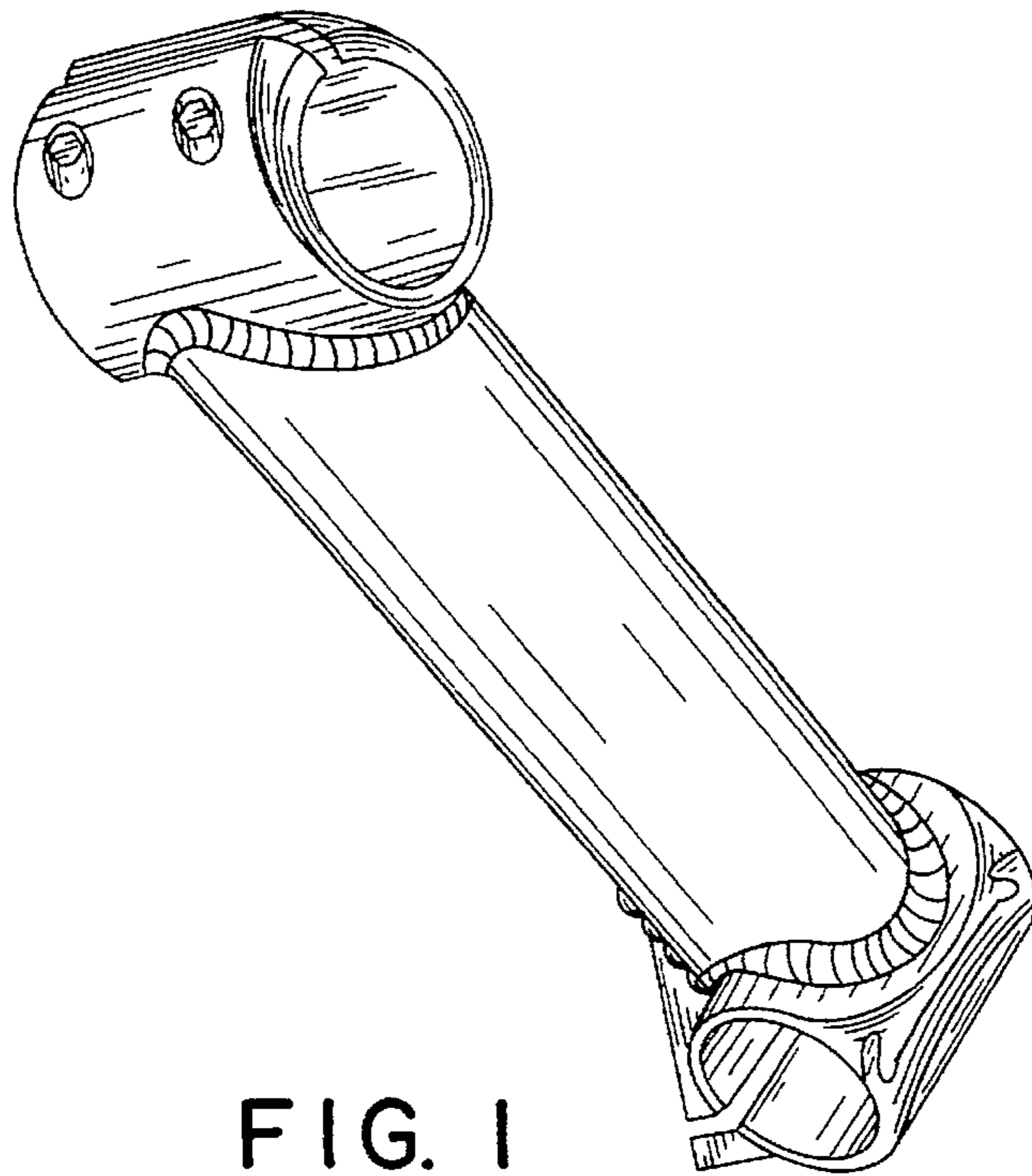

FIG. 1

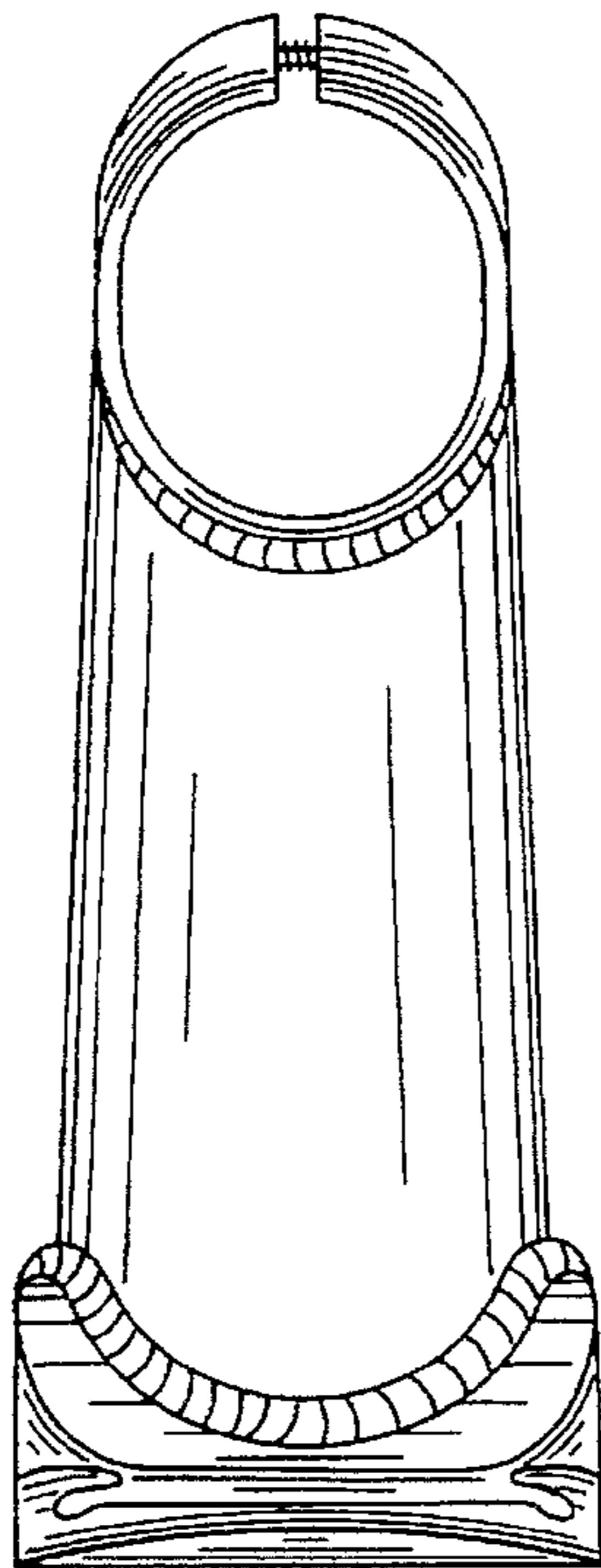

FIG. 2

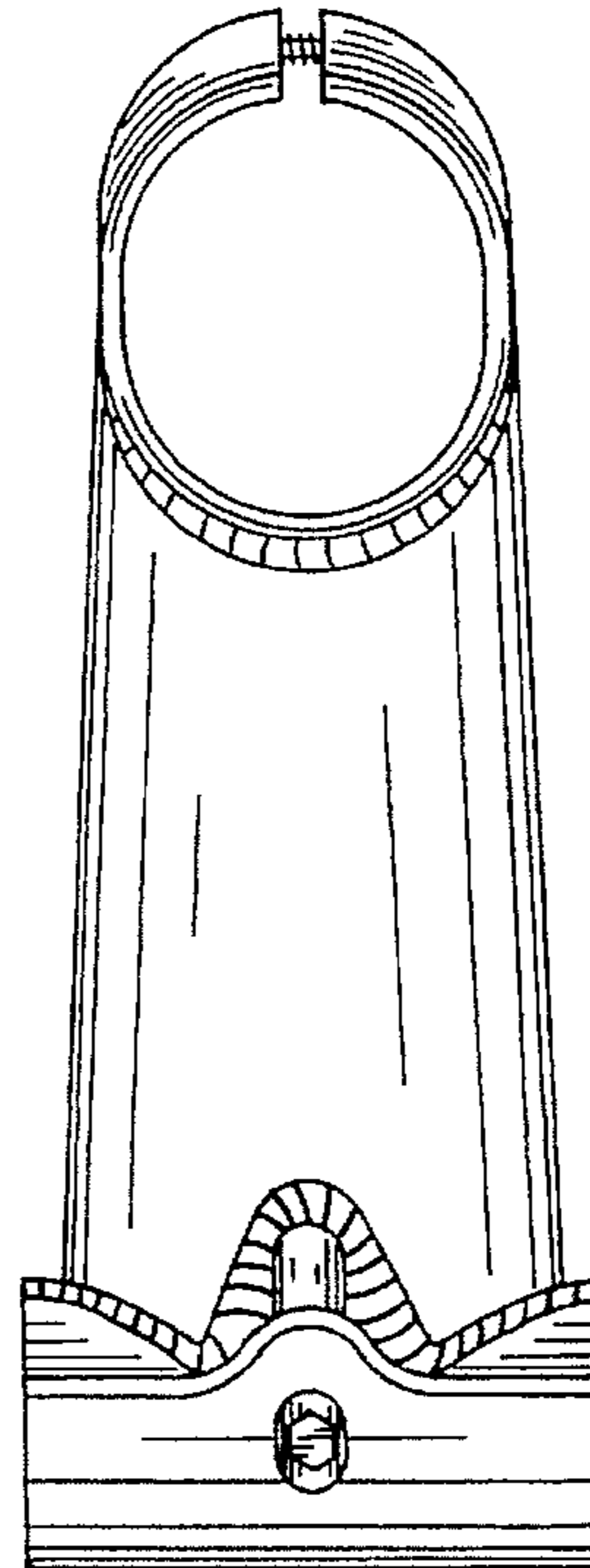

FIG. 3

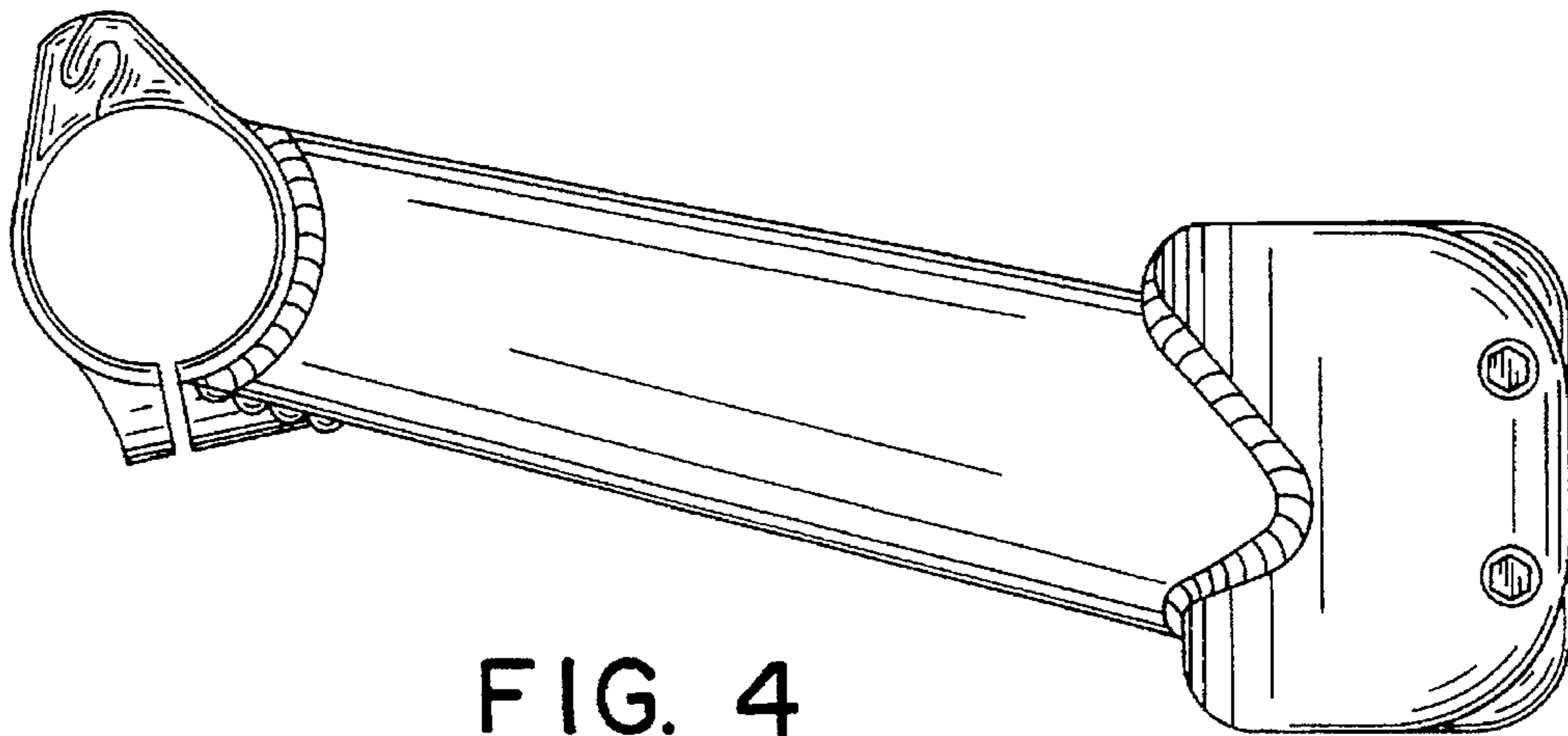

FIG. 4

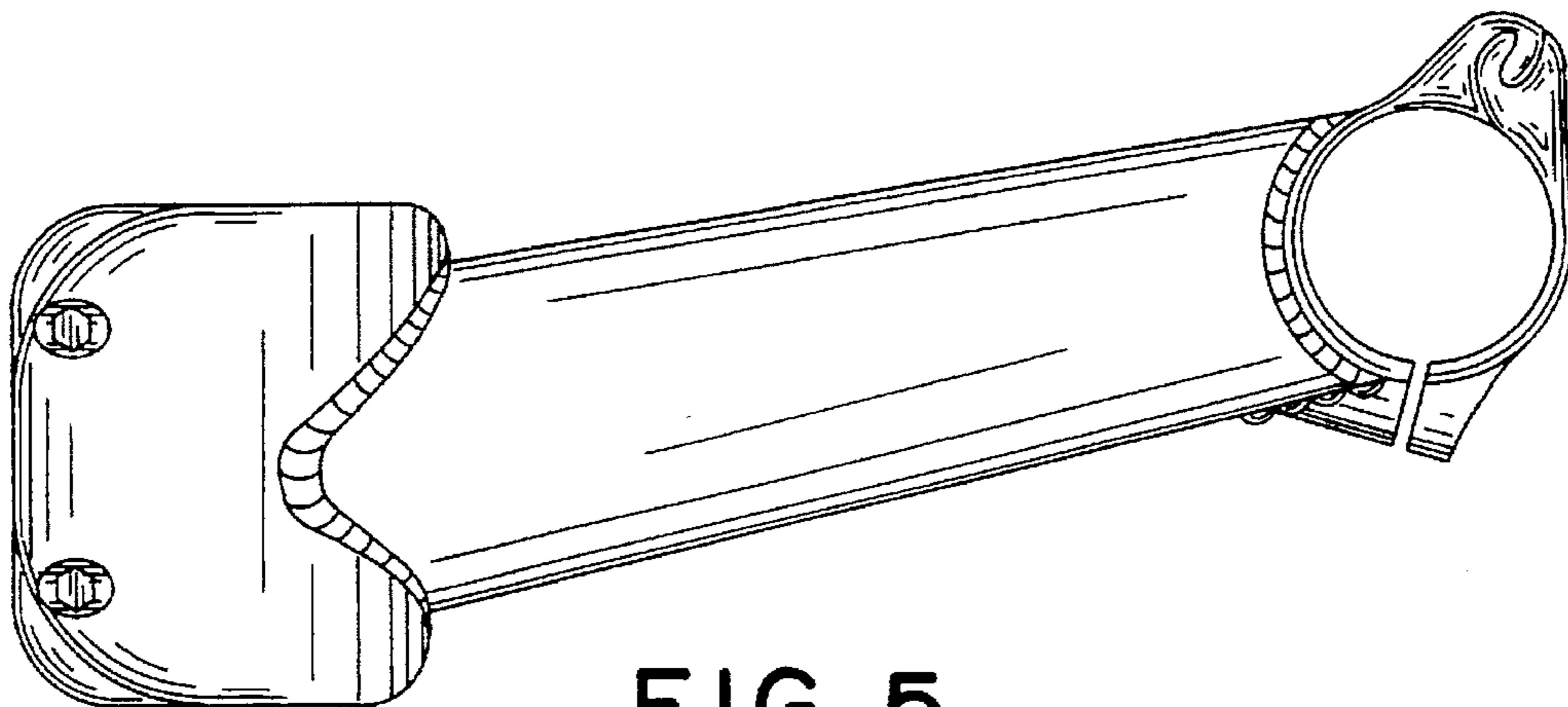

FIG. 5

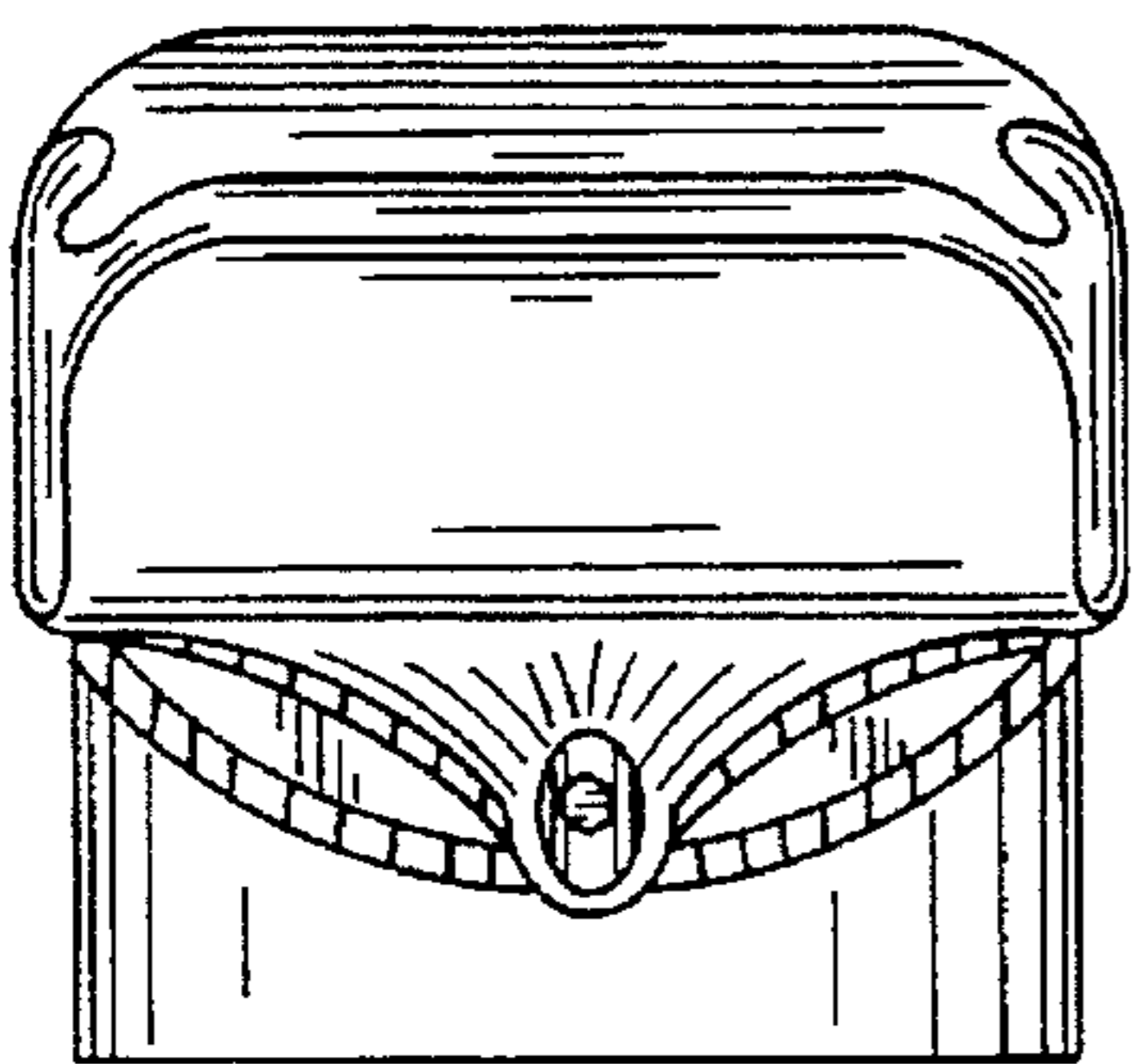

FIG. 6

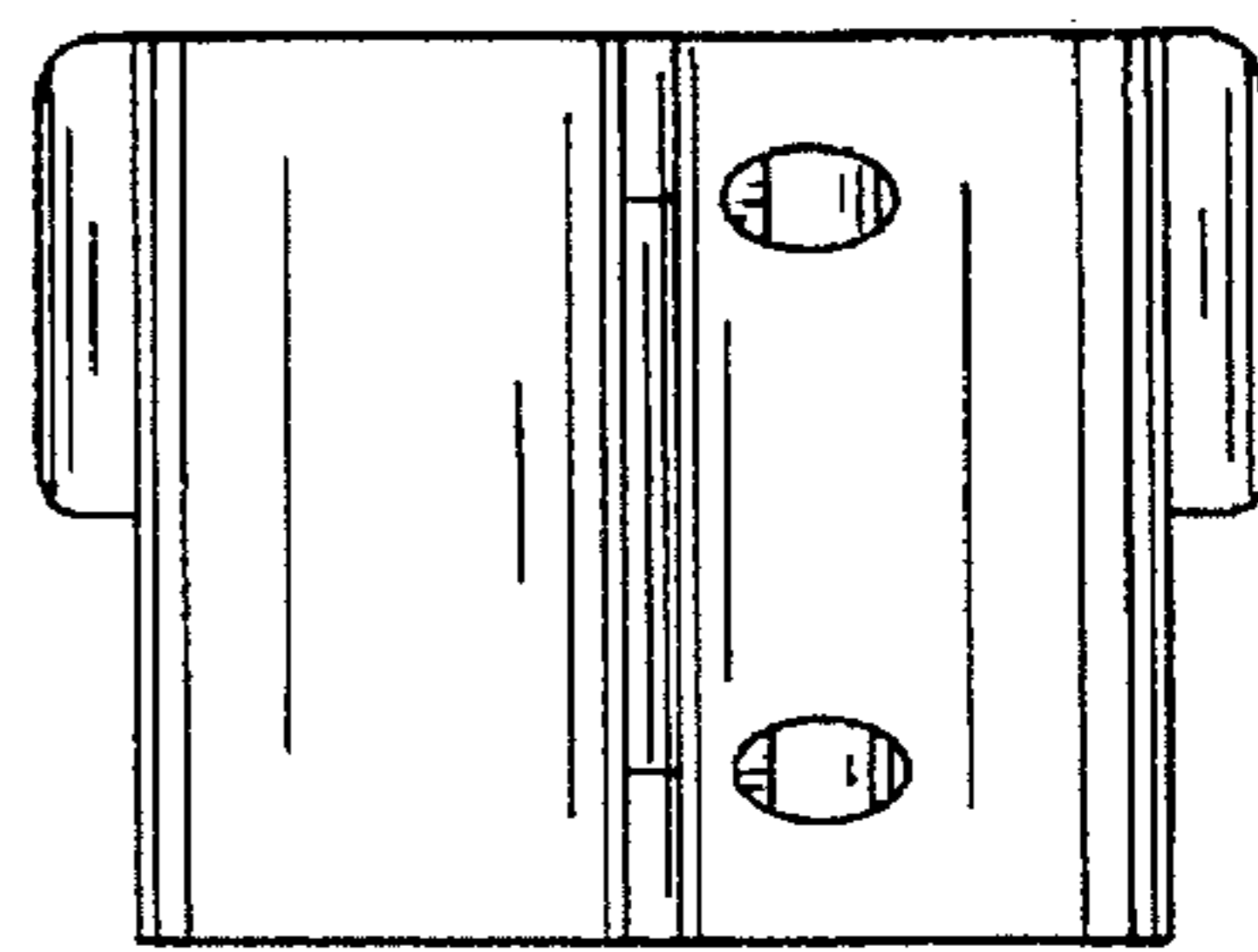

FIG. 7

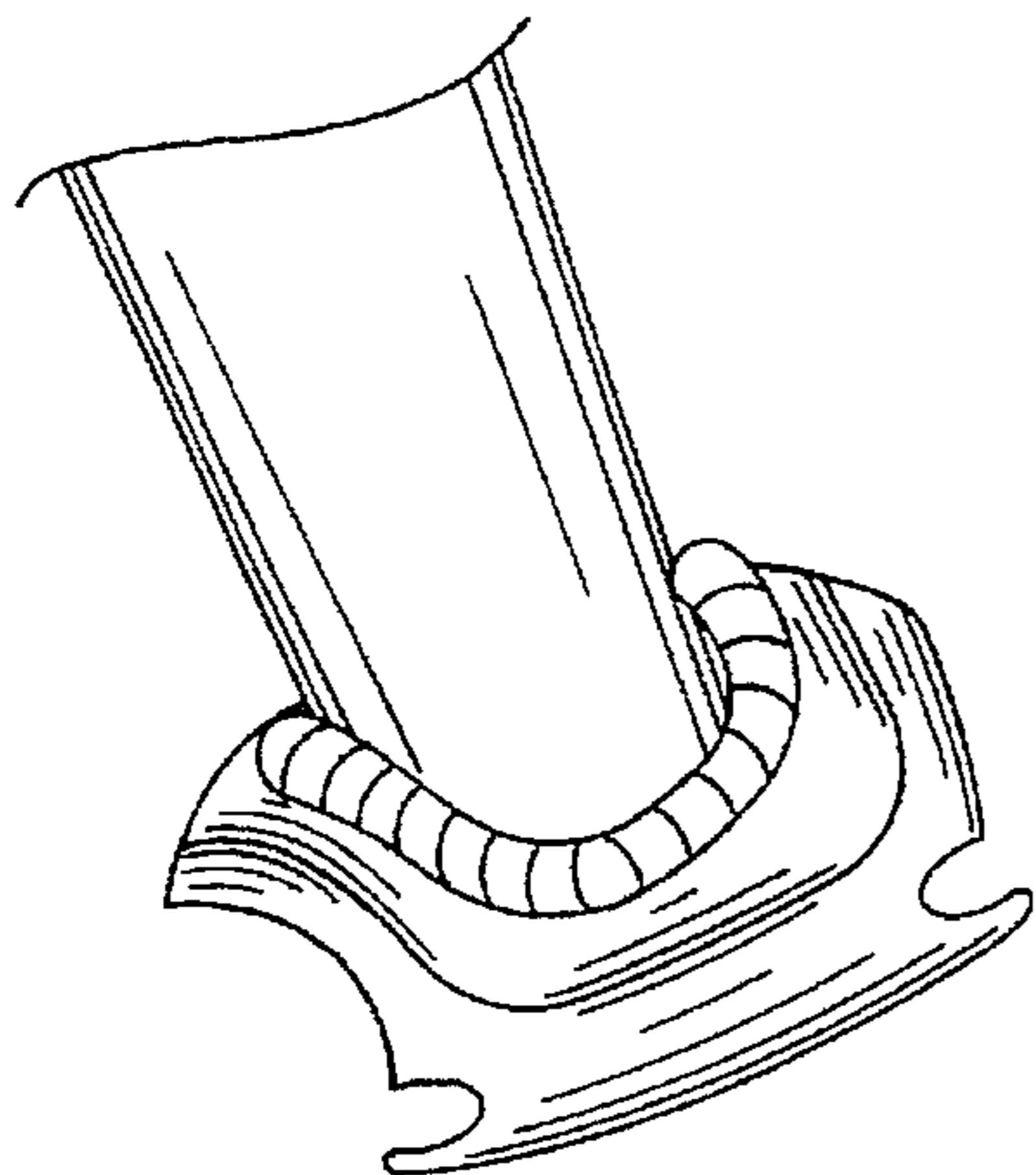

FIG. 8

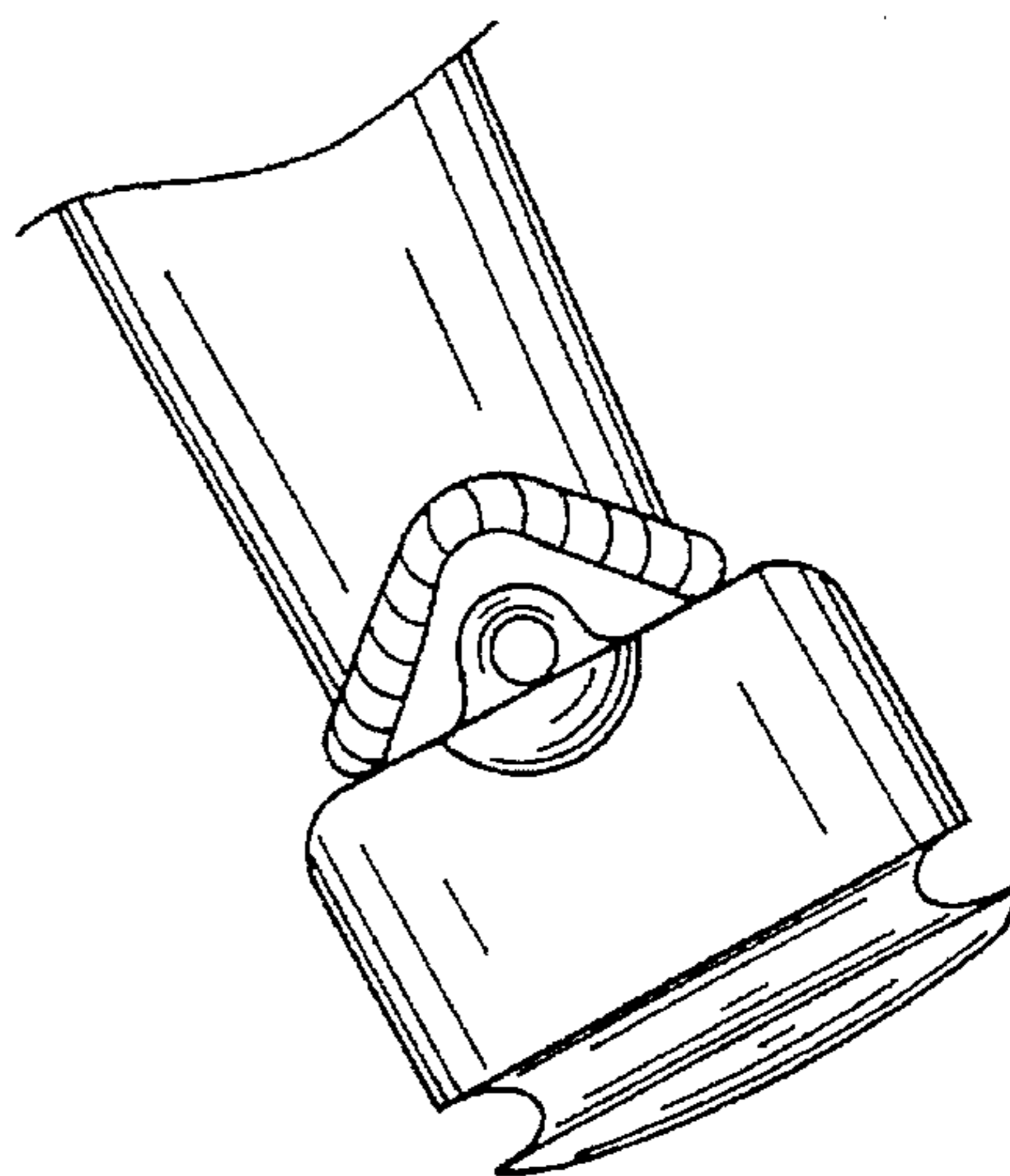

FIG. 9

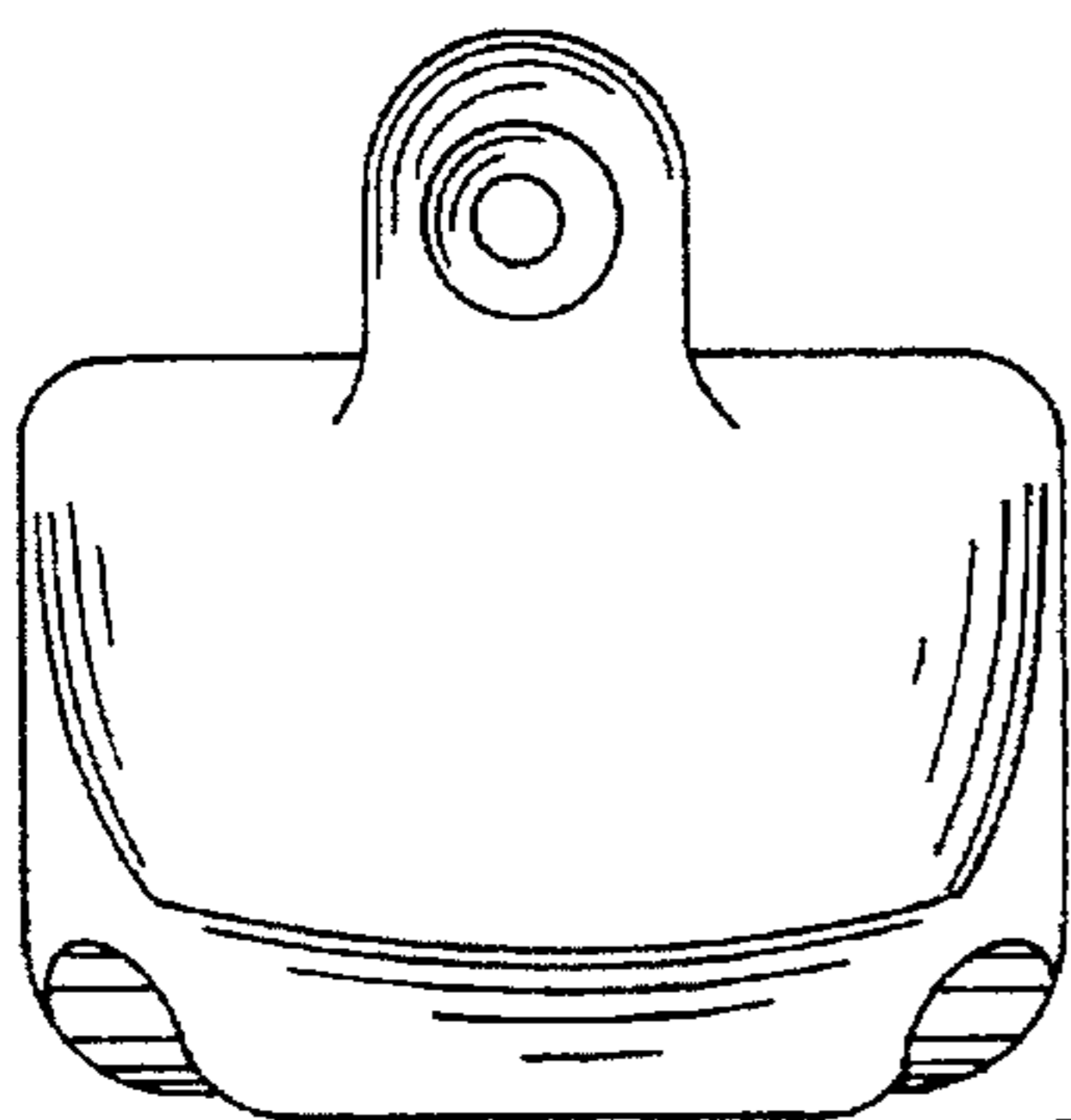

FIG. 10

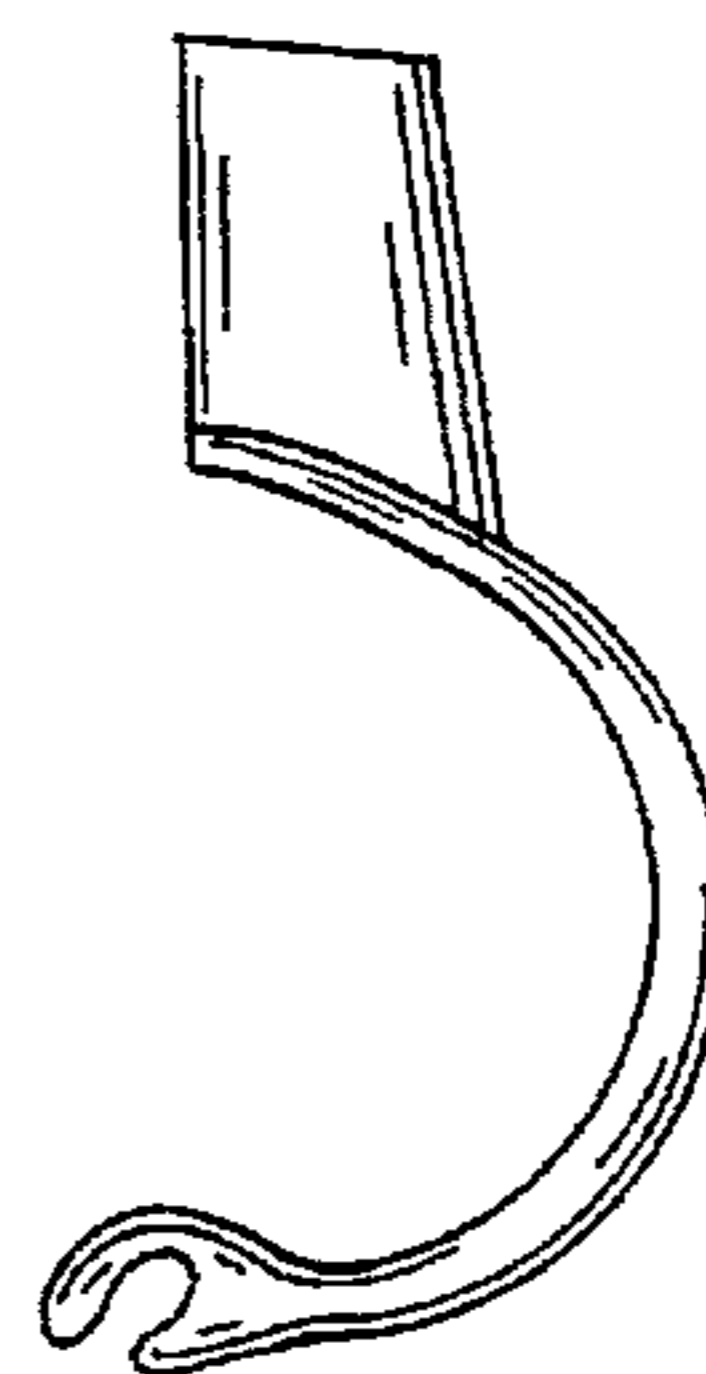

FIG. 11

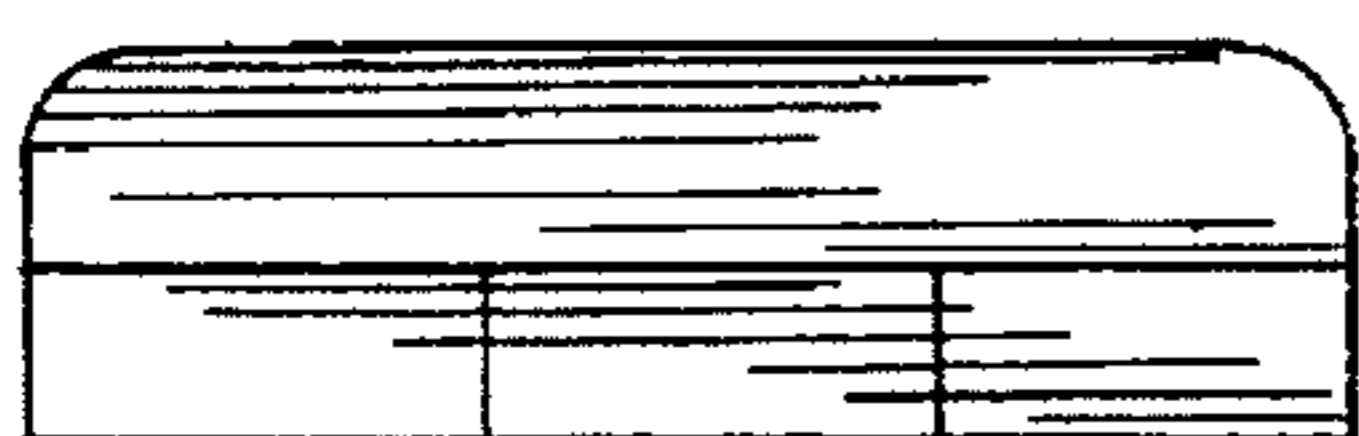

FIG. 12



FIG. 13