



US00D380991S

United States Patent [19]
Deming

[11] **Patent Number: Des. 380,991**
[45] **Date of Patent: **Jul. 15, 1997**

[54] **ALL-TERRAIN WHEELCHAIR**

DESCRIPTION

[76] **Inventor: Micheal S. Deming**, 141 W. Pinestead Rd., Pensacola, Fla. 32503

[**] **Term: 14 Years**

[21] **Appl. No.: 37,759**

[22] **Filed: Apr. 18, 1995**

[51] **LOC (6) Cl. 12-12**

[52] **U.S. Cl. D12/131**

[58] **Field of Search D12/128, 131; 280/304.1, 250.1, 253; 180/907**

[56] **References Cited**

U.S. PATENT DOCUMENTS

4,892,323	1/1990	Oxford .	
4,926,777	5/1990	Davis, Jr. .	
5,020,818	6/1991	Oxford .	
5,149,118	9/1992	Oxford .	
5,290,055	3/1994	Treat, Jr.	D12/131
5,427,398	6/1995	Weybrecht	D12/131

Primary Examiner—Kay H. Chin
Attorney, Agent, or Firm—Saliwanchik, Lloyd & Saliwanchik

[57] **CLAIM**

The ornamental design for a all-terrain wheelchair, as shown and described.

FIG. 1 is a side view of an all-terrain wheelchair showing my new design;

FIG. 2 is a front view thereof;

FIG. 3 is a rear perspective view thereof;

FIG. 4 is a side view thereof with smooth-tread tires in broken lines;

FIG. 5 is a side view of a second embodiment of the all-terrain wheelchair, the sole difference from the first embodiment being in the different configuration of the footrest;

FIG. 6 is a side view of a third embodiment of the all-terrain wheelchair showing the reclining chair design;

FIG. 7 is a front view of FIG. 6;

FIG. 8 is a rear view of FIG. 6 showing the pivoted rear wheels;

FIG. 9 is a rear view of a fourth embodiment of the all-terrain wheelchair showing the reclining chair with umbrella attached thereto; and,

FIG. 10 is a rear view of a fifth embodiment of the all-terrain wheelchair showing a single rear wheel.

The broken lines of wheels are for illustrative purposes only and form no part of the claimed design.

1 Claim, 10 Drawing Sheets

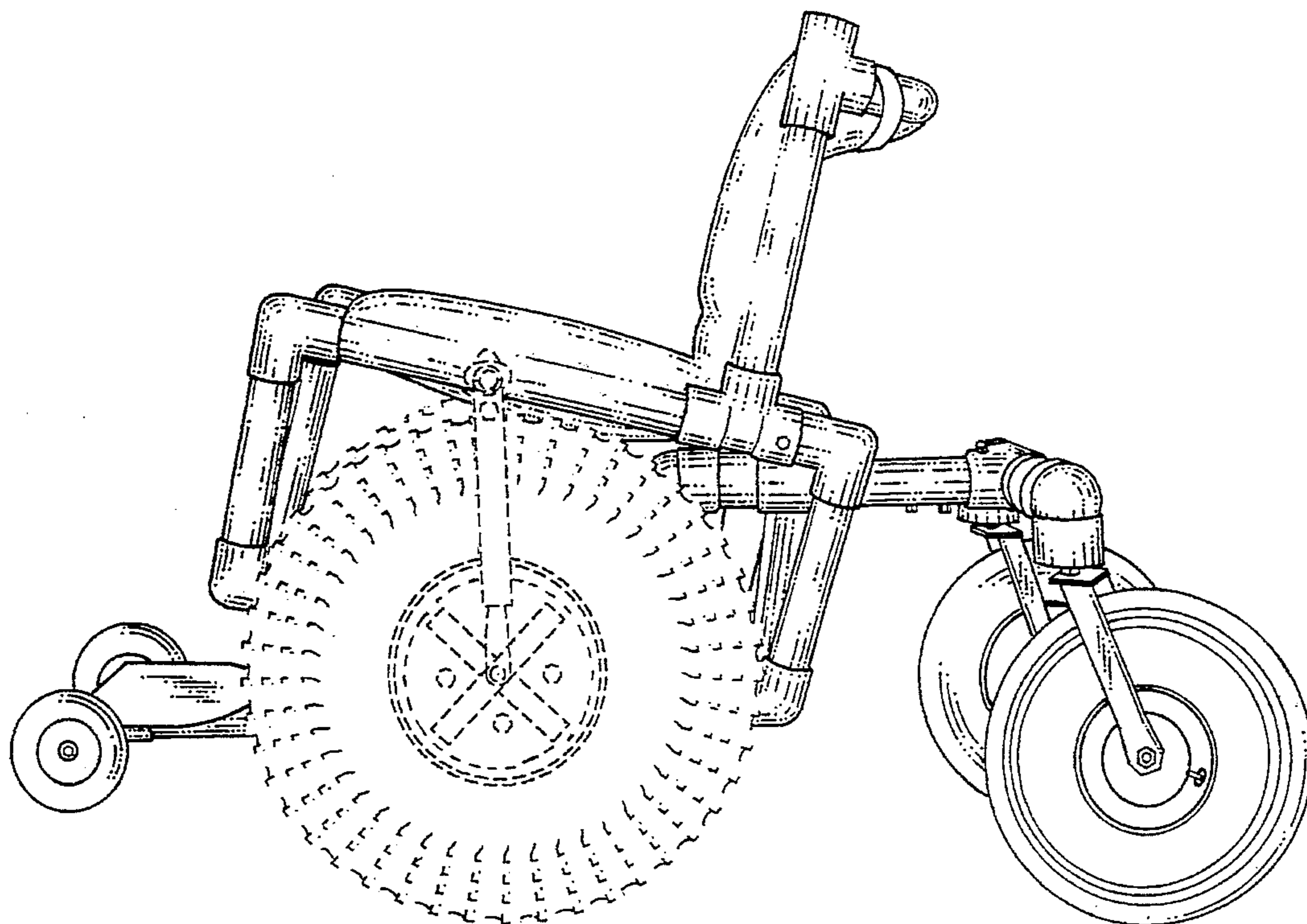
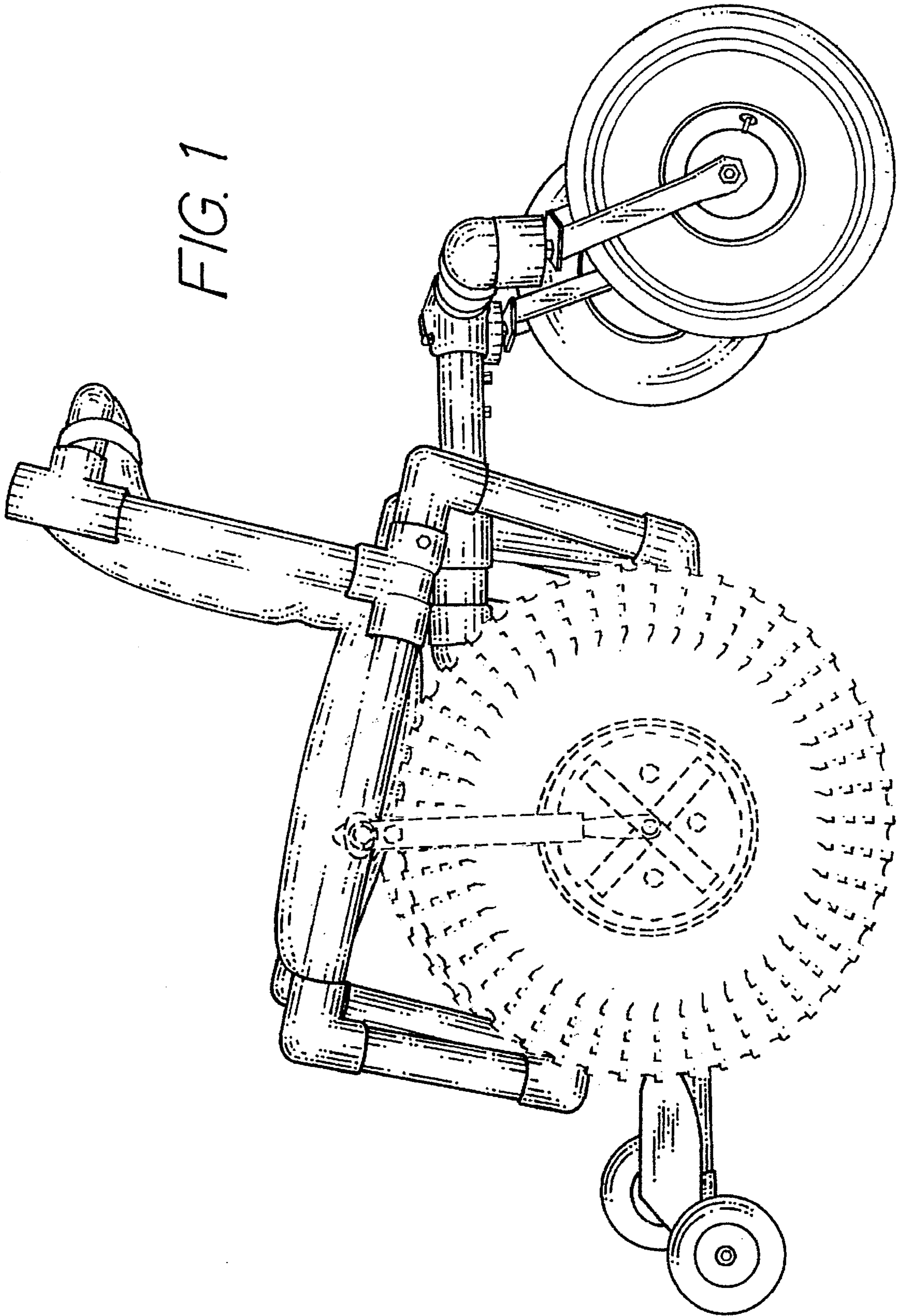

FIG. 1



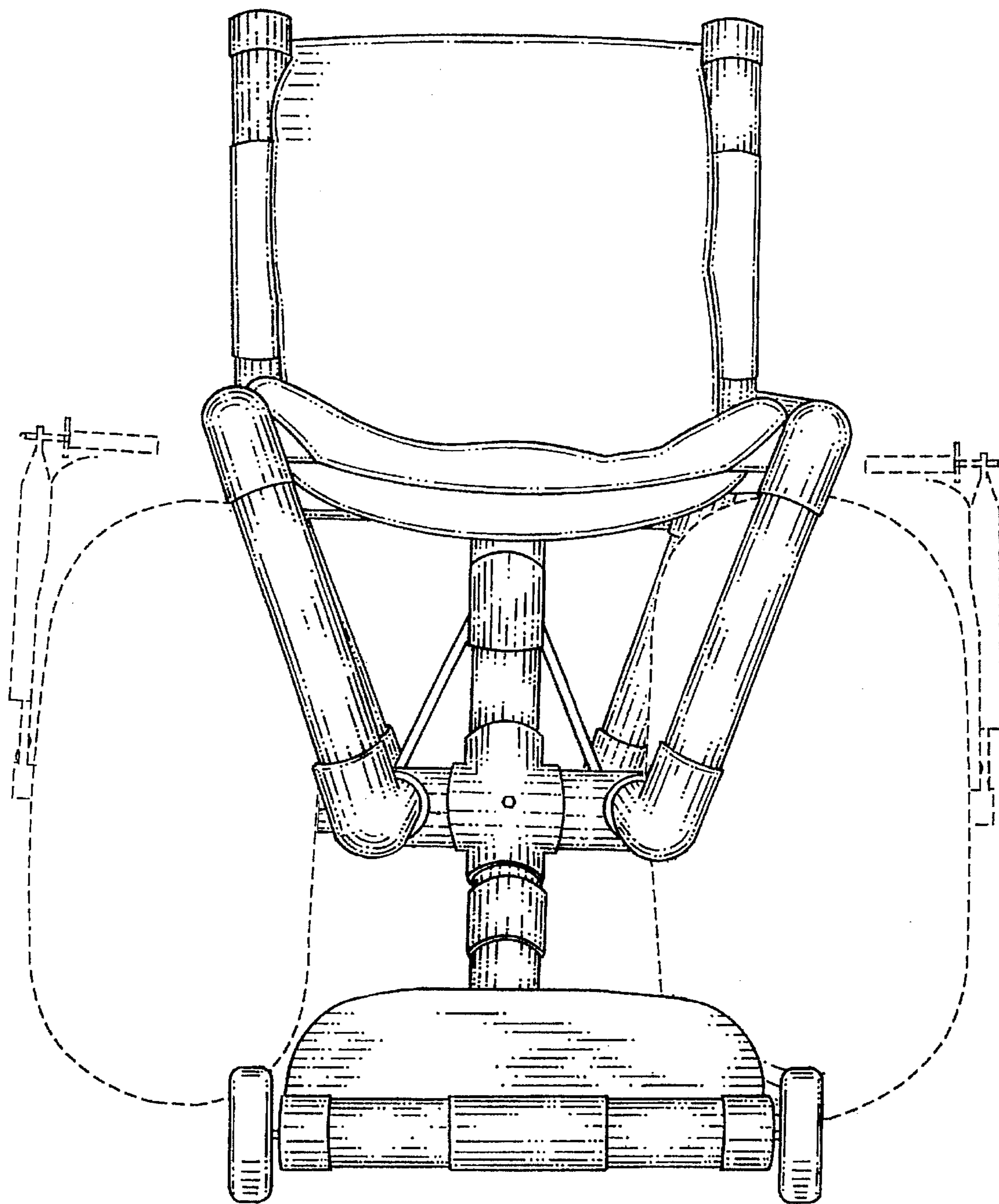

FIG. 2

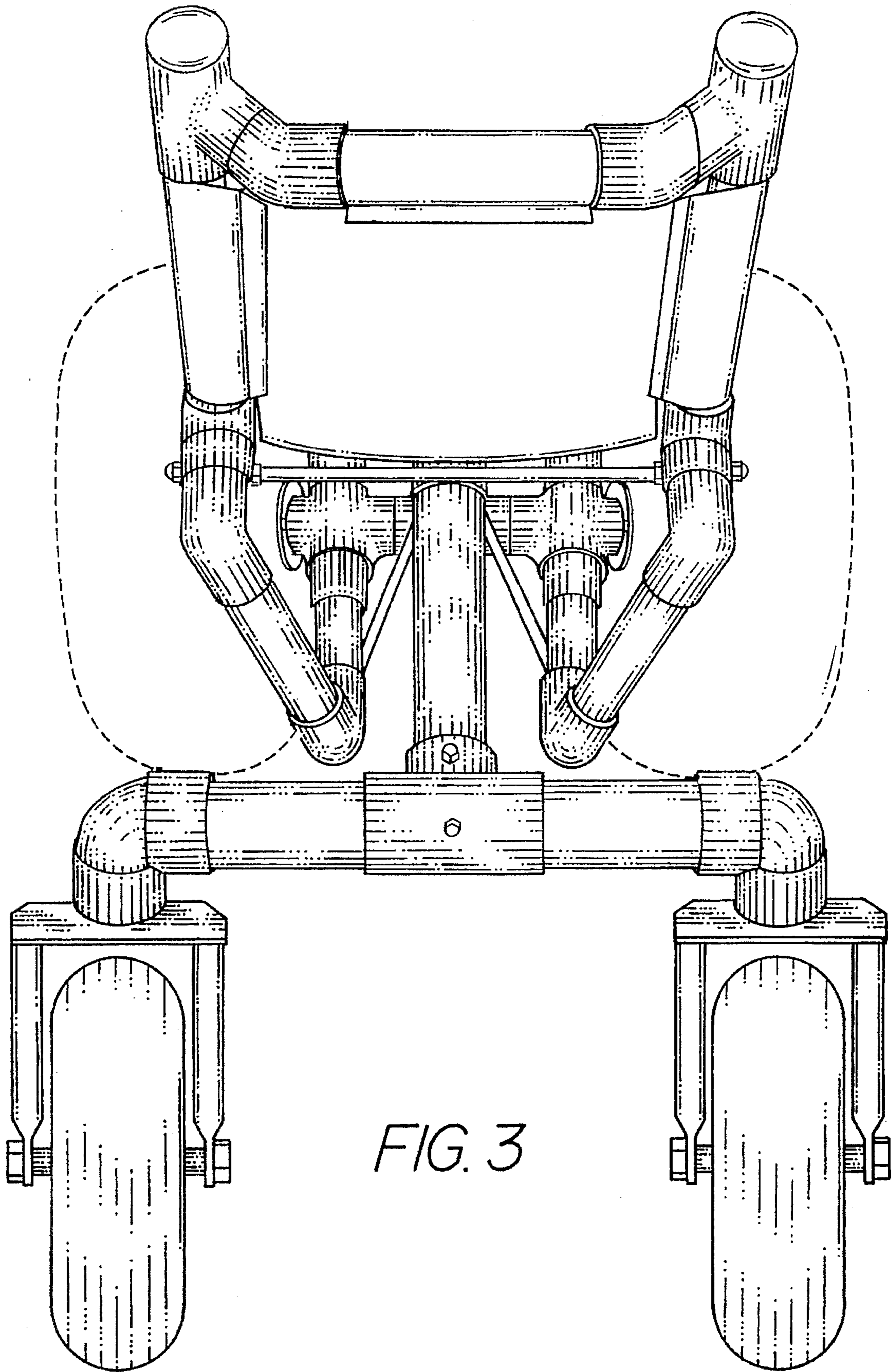

FIG. 3

FIG. 4

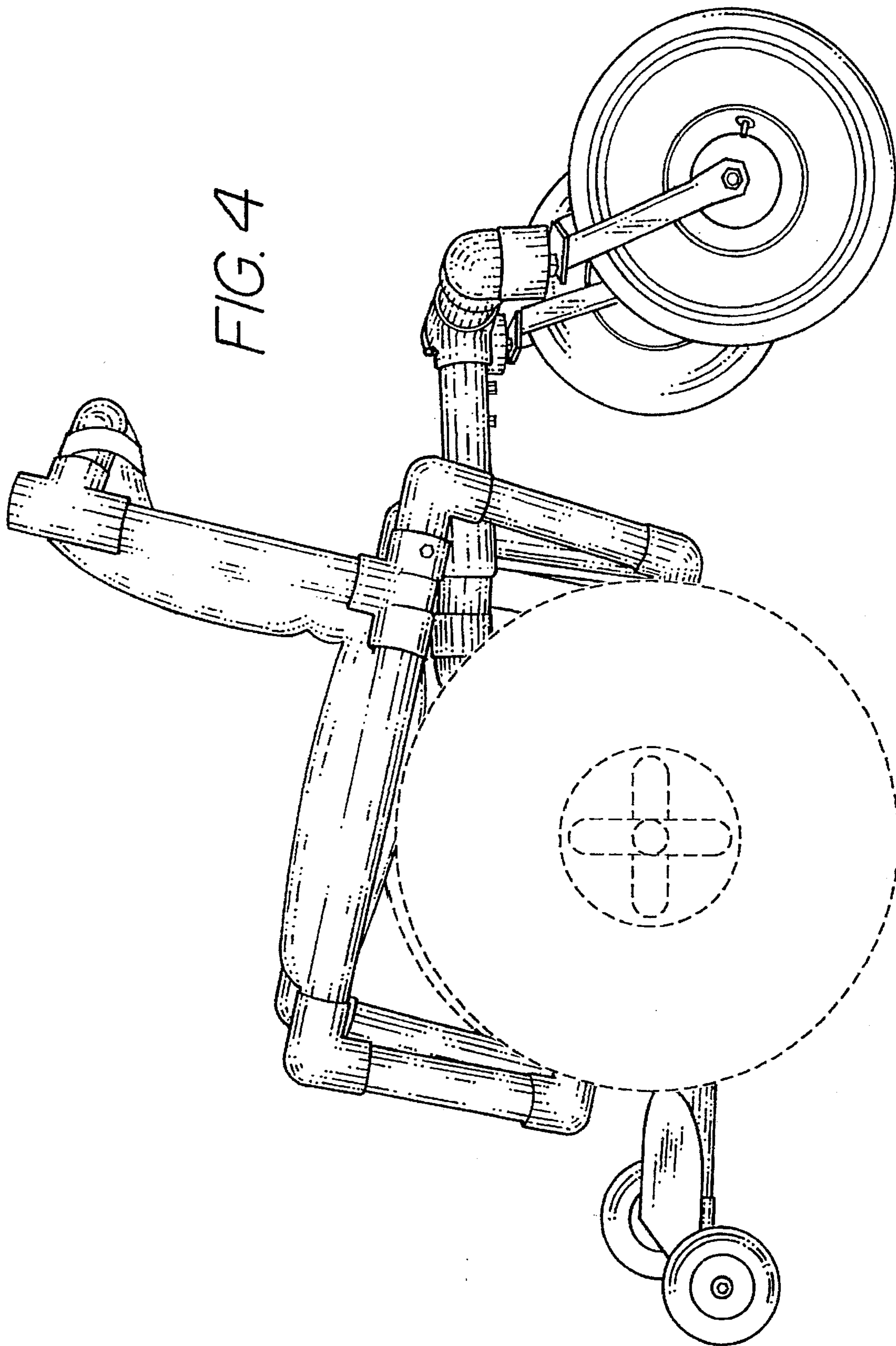
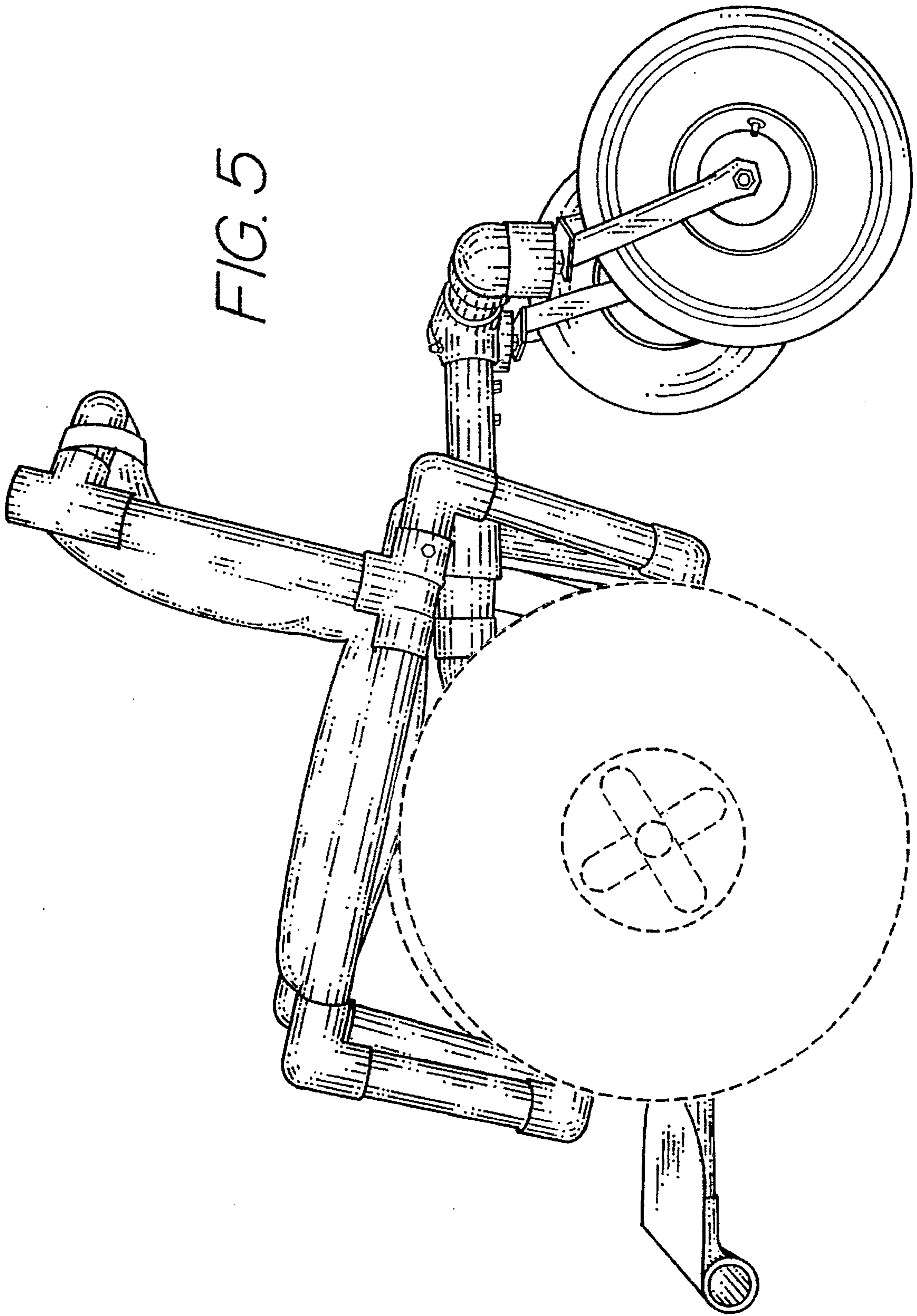

FIG. 5



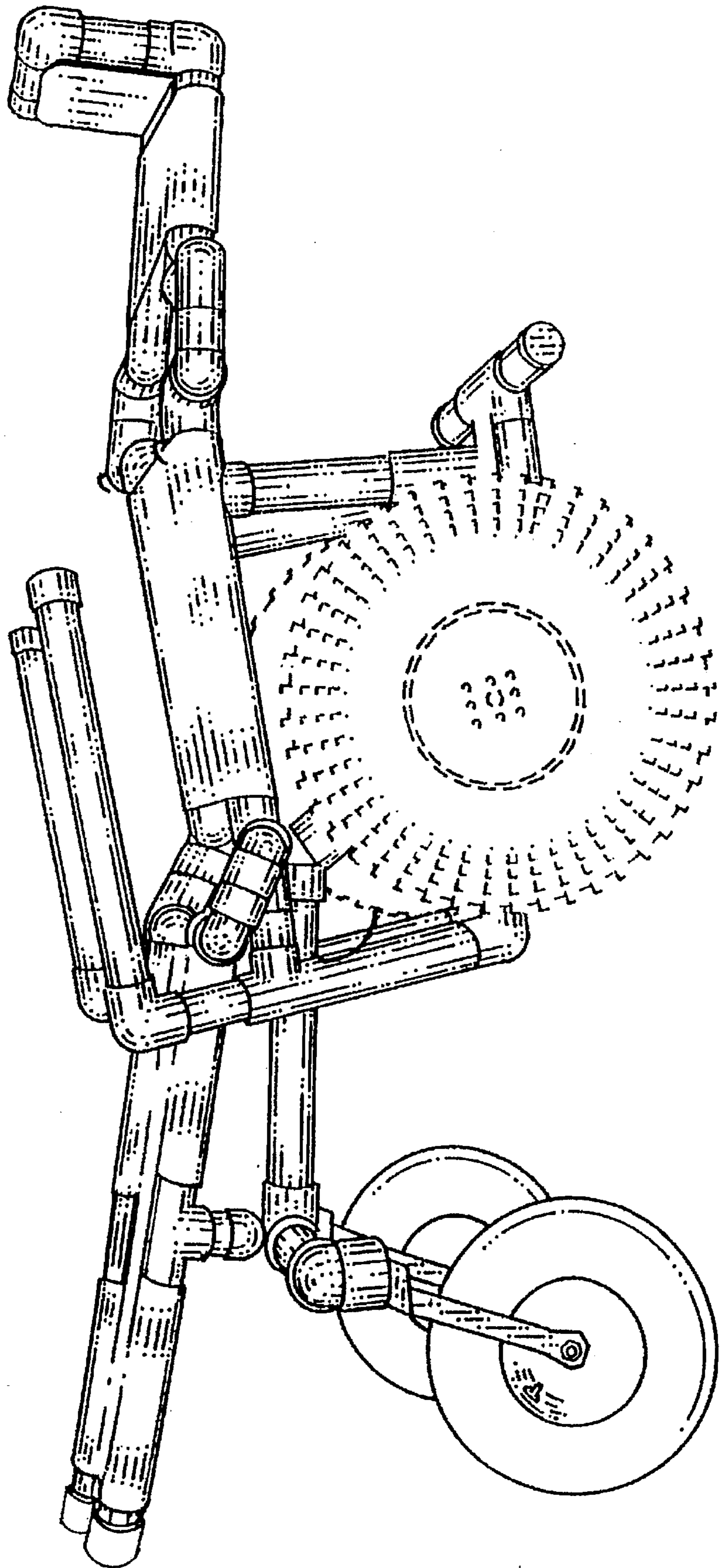

FIG. 6

FIG. 7

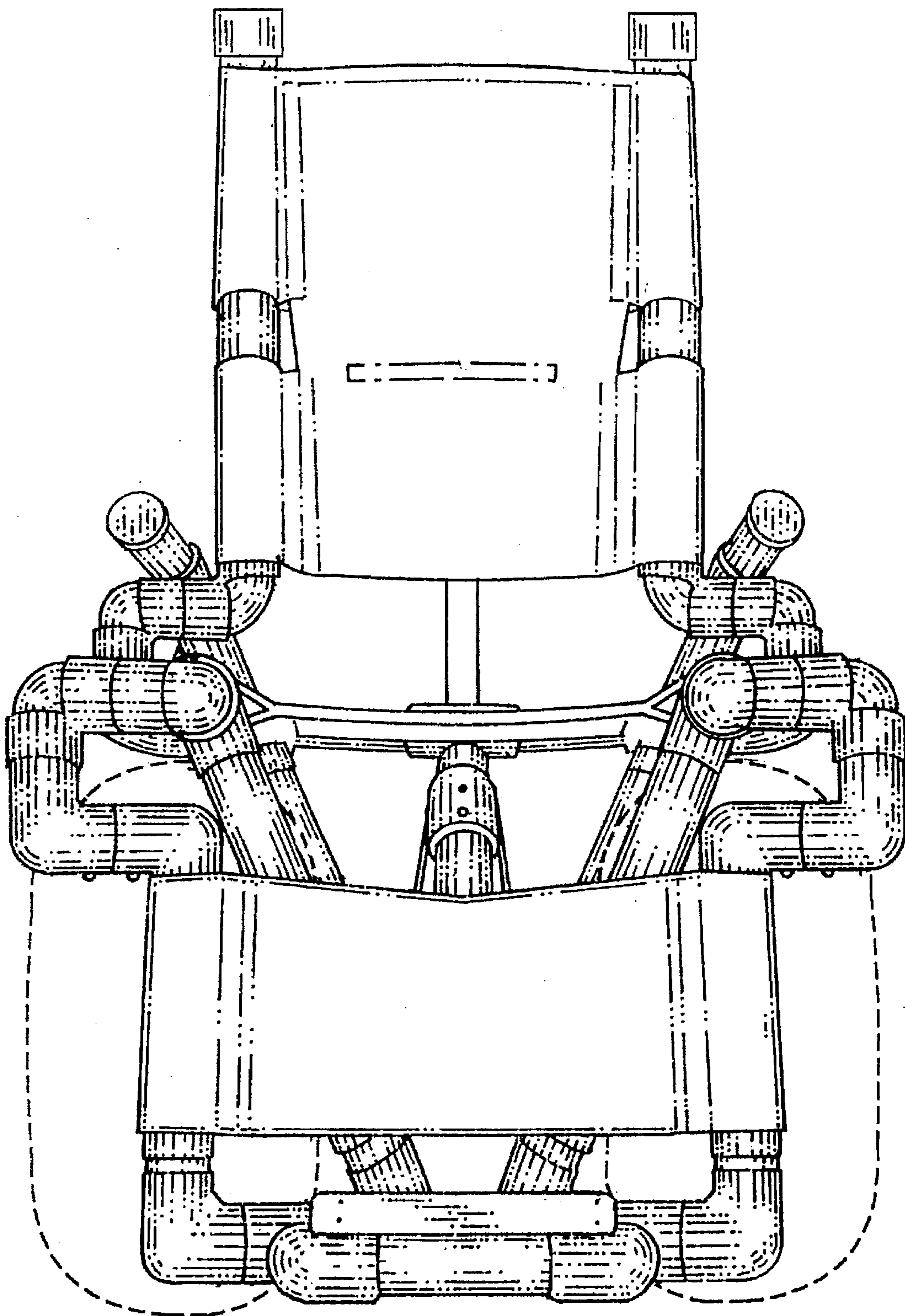

FIG. 8

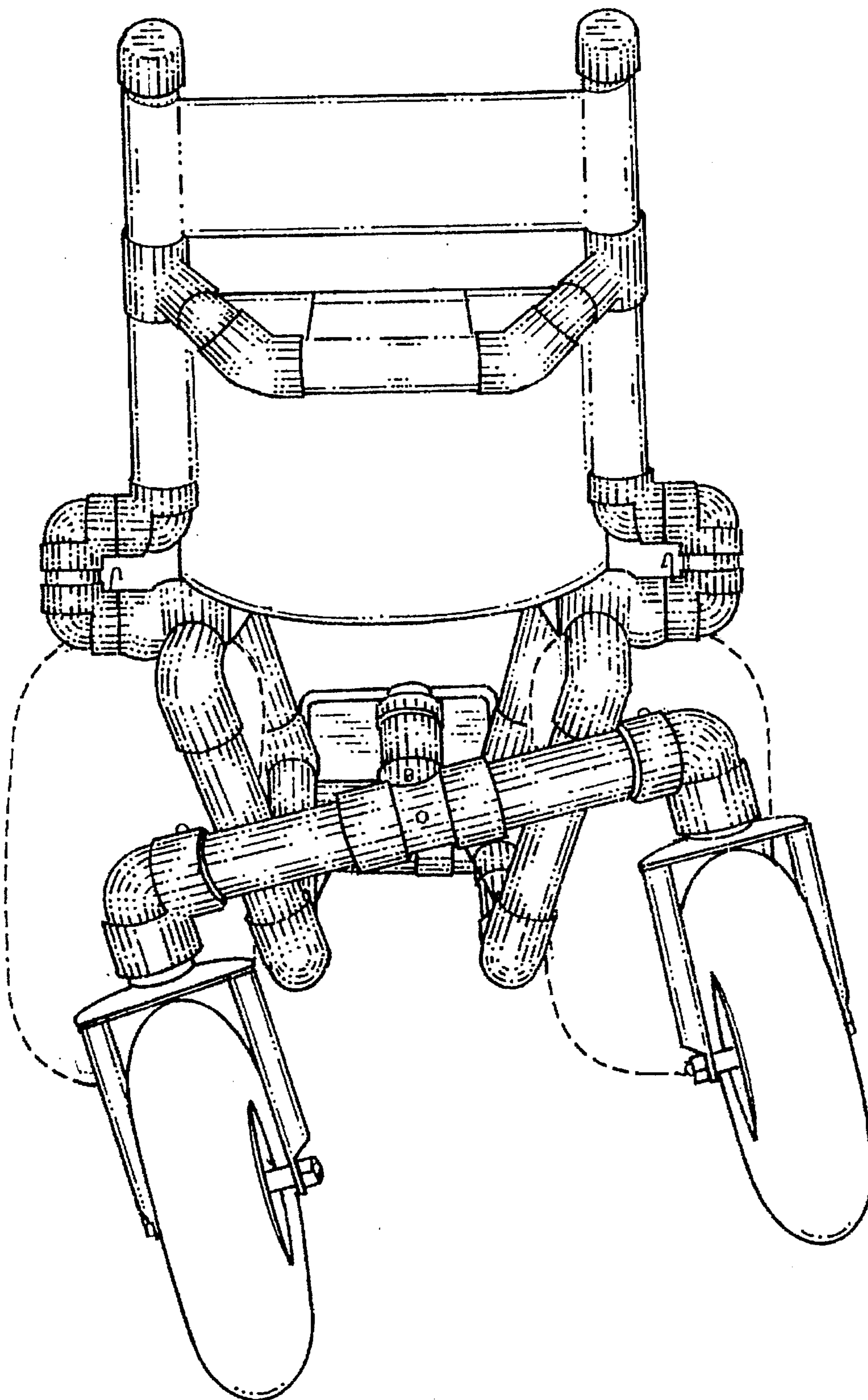
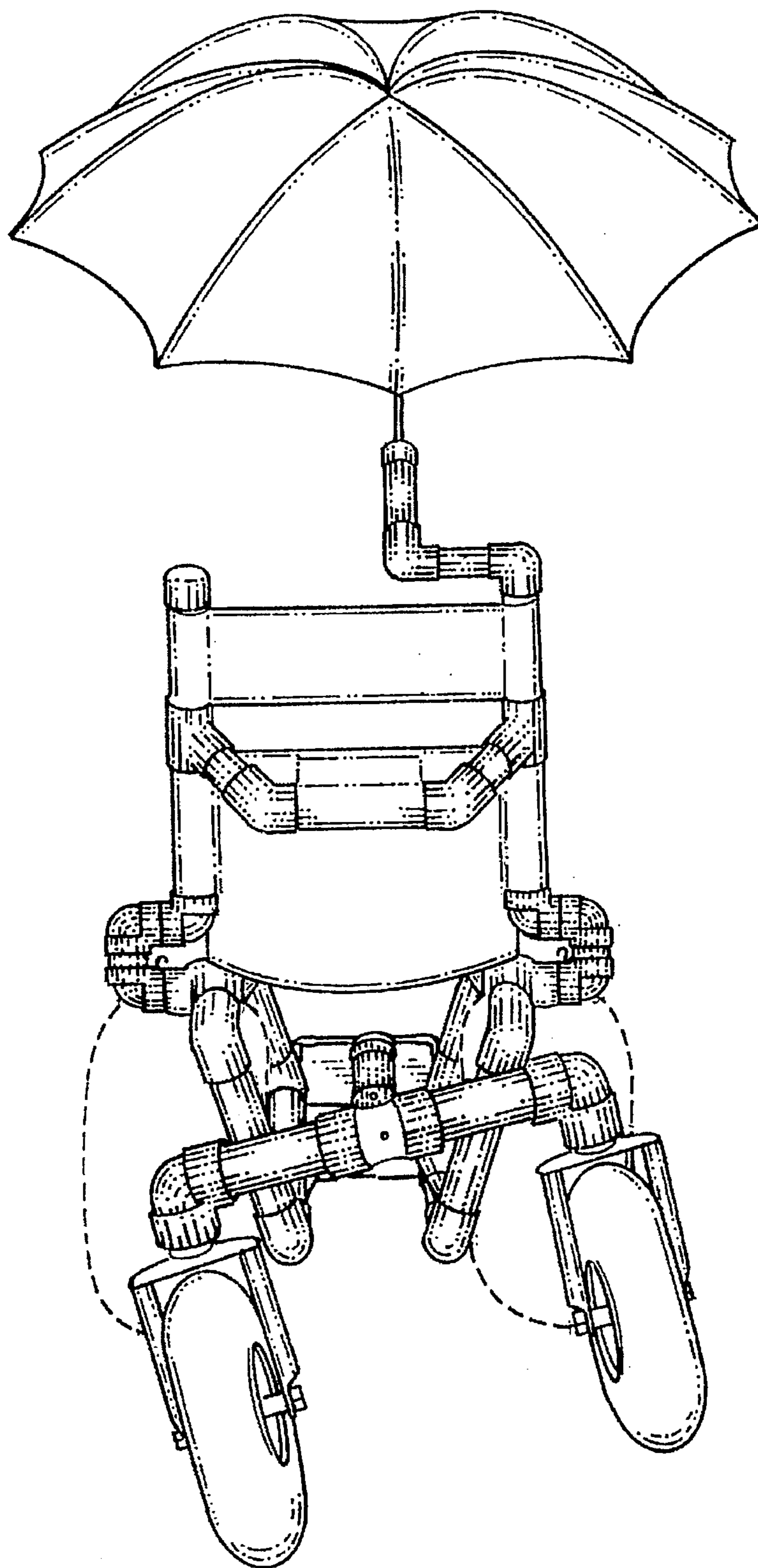

FIG. 9



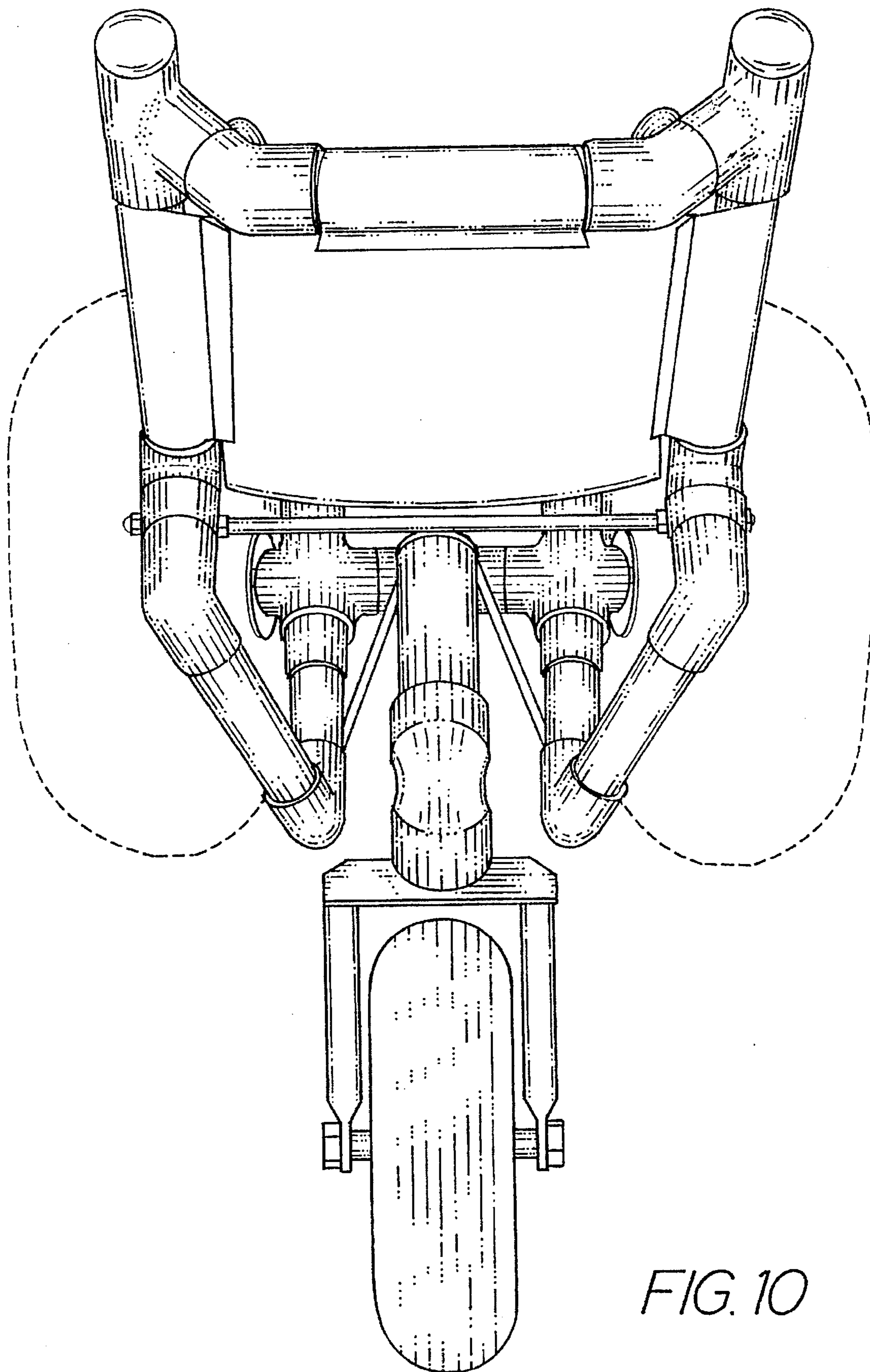

FIG. 10