



US00D380725S

United States Patent [19]

Edmon

[11] Patent Number: **Des. 380,725**

[45] Date of Patent: ****Jul. 8, 1997**

[54] MOTORIZED BOAT

[76] Inventor: **Arthur C. Edmon**, 4810 SE. 10 Ter.,
Gresham, Oreg. 97080

[**] Term: **14 Years**

[21] Appl. No.: **51,064**

[22] Filed: **Mar. 1, 1996**

[51] LOC (6) Cl. **12-06**

[52] U.S. Cl. **D12/300; D12/317**

[58] Field of Search **D12/300, 317,
D12/318; 440/79, 75, 89, 88**

[56] References Cited

U.S. PATENT DOCUMENTS

4,344,760	8/1982	Kulikowski	440/79
4,428,734	1/1984	Ludlow	440/79
5,205,764	4/1993	Thiger	440/79

Primary Examiner—Kay H. Chin
Attorney, Agent, or Firm—Harold H. Dutton, Jr.; W. Charles
L. Jamison; Diane F. Liebman

[57] CLAIM

The ornamental design for a motorized boat, as shown and described.

DESCRIPTION

FIG. 1 is a perspective view of a motorized boat showing my new design;

FIG. 2 is a right side view thereof; and the left side view is a mirror image thereof;

FIG. 3 is a front view thereof;

FIG. 4 is a rear view thereof;

FIG. 5 is a top view thereof; and,

FIG. 6 is a bottom view thereof.

1 Claim, 4 Drawing Sheets

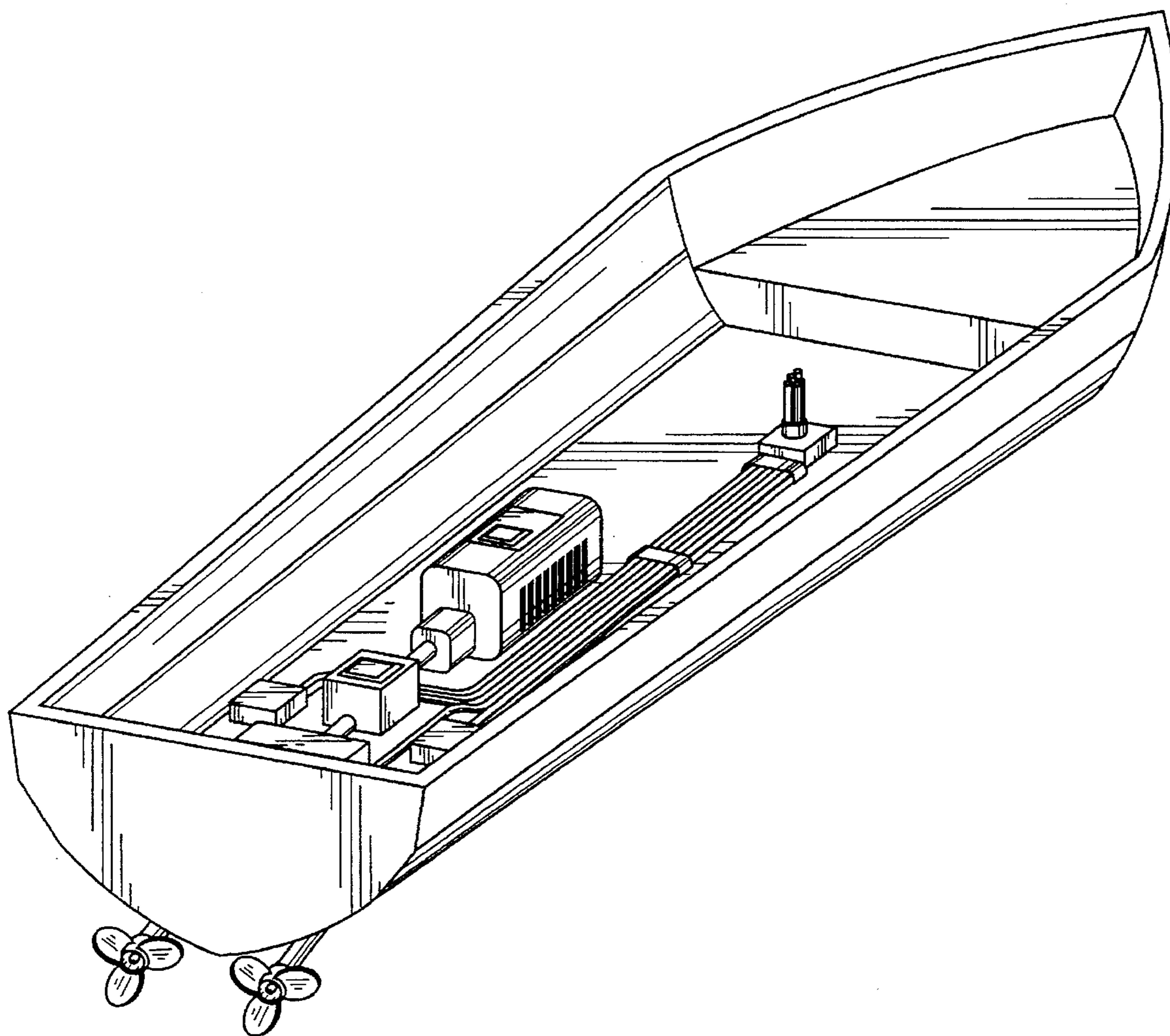

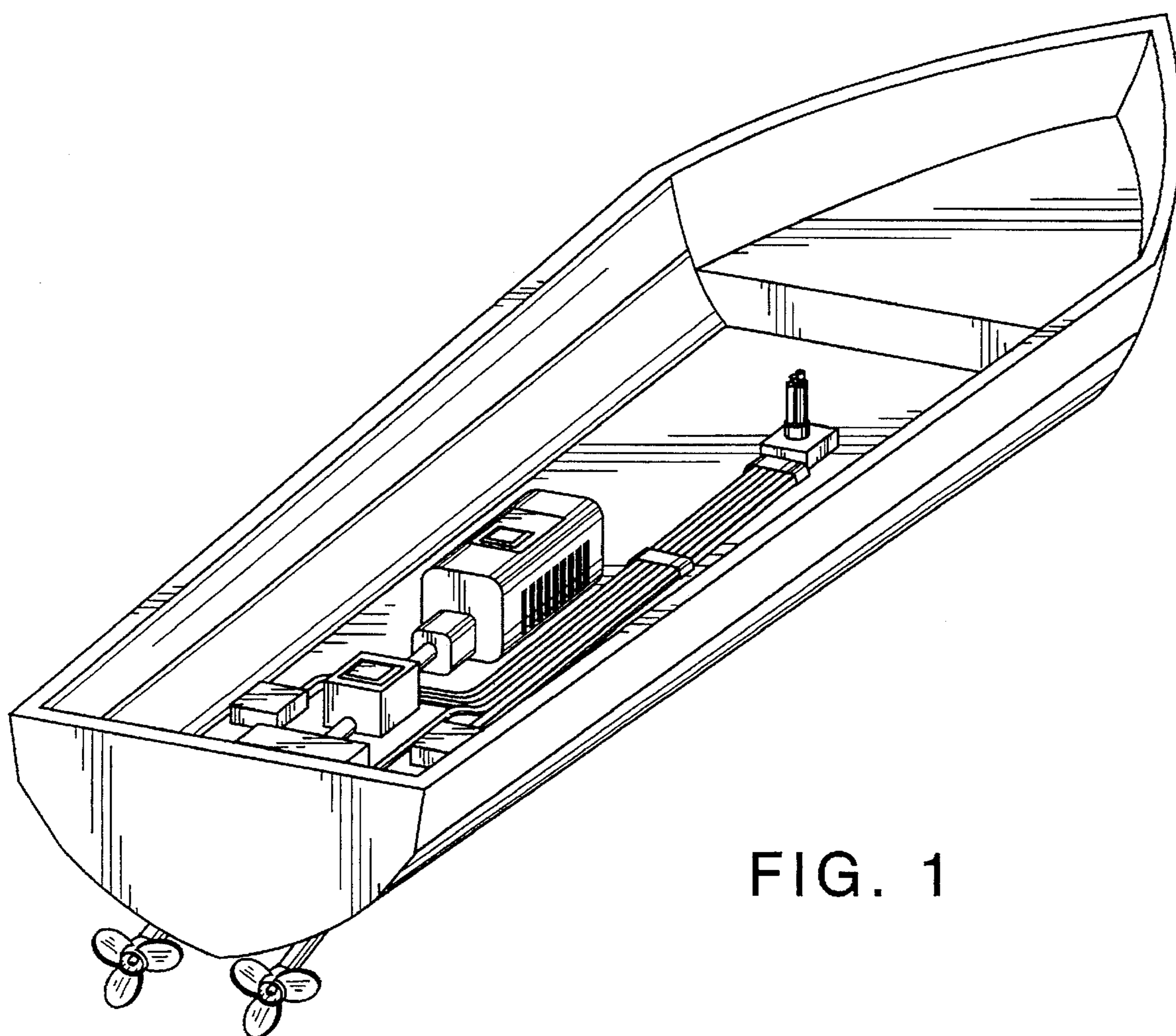

FIG. 1

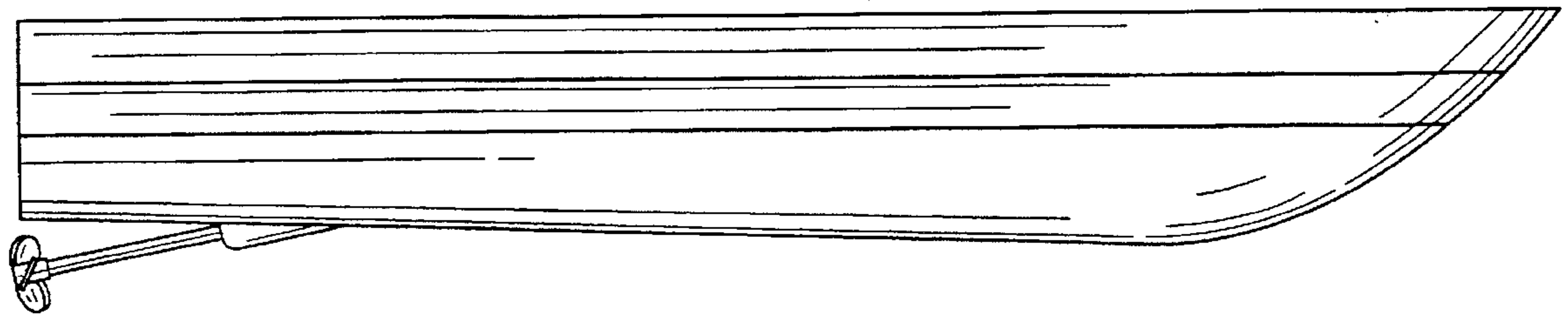

FIG. 2

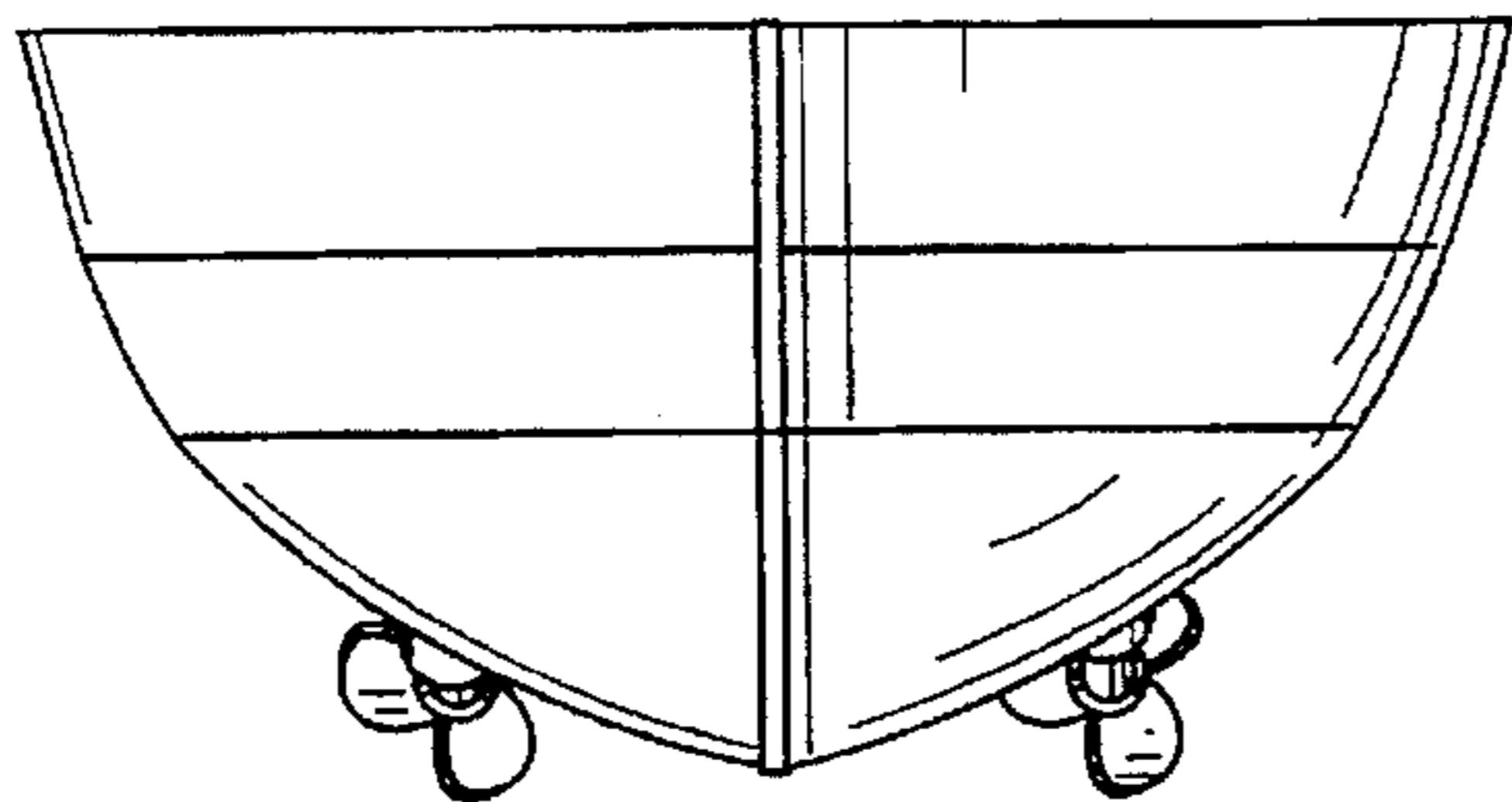

FIG. 3

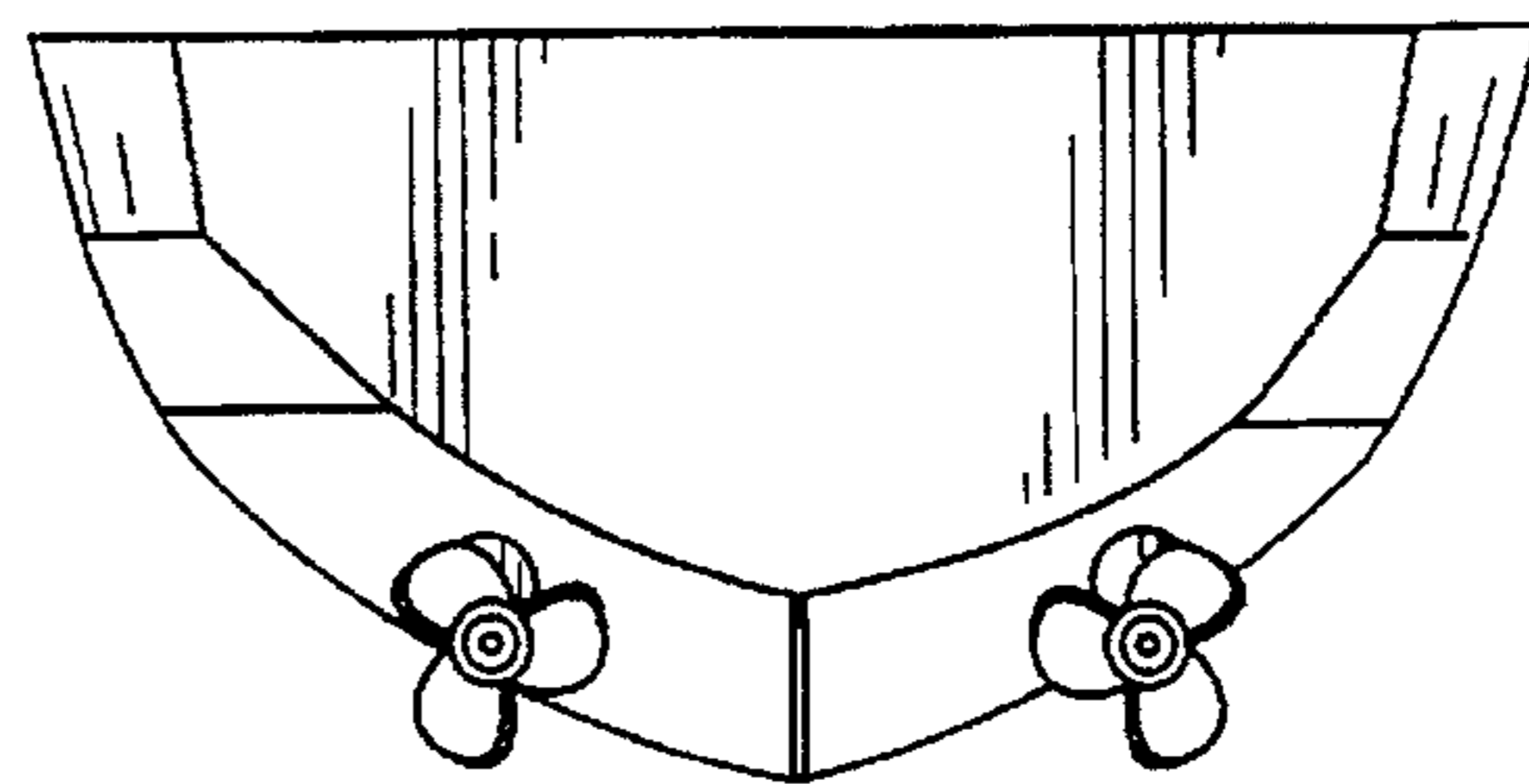

FIG. 4

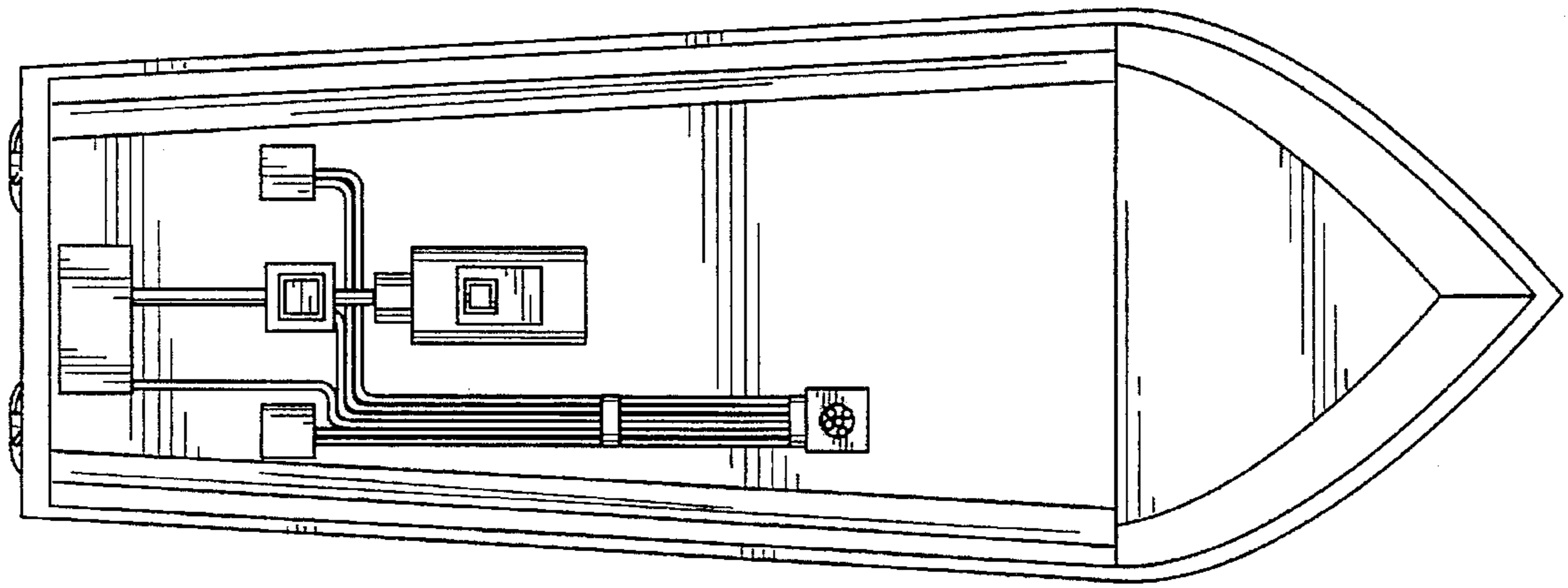

FIG. 5

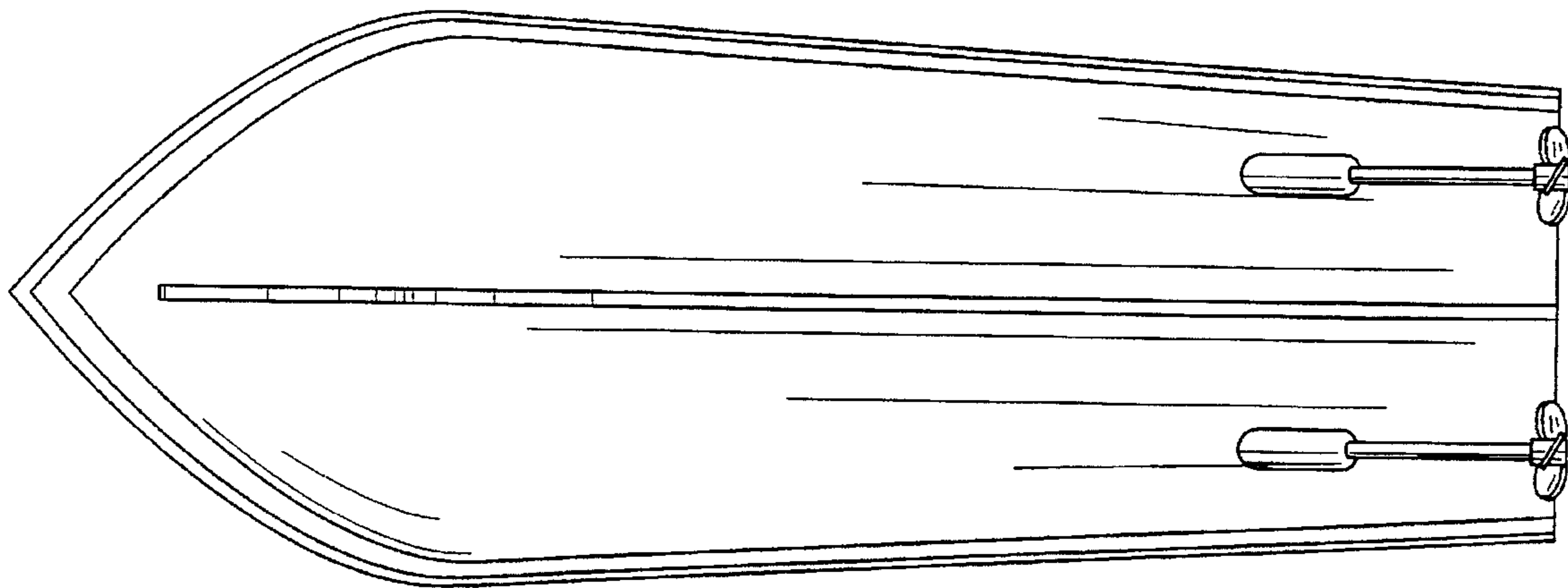

FIG. 6