



US00D380706S

United States Patent [19] Gardner

[11] Patent Number: **Des. 380,706**
[45] Date of Patent: ****Jul. 8, 1997**

[54] **TRUCK BED INSERT PERMITTING
RETRIEVAL OF GOODS WITHIN TRUCK
BED**

4,968,084 11/1990 Asher 296/57.1
5,004,287 4/1991 Doyle 296/57.1
5,039,154 8/1991 Lewis 296/60

[76] Inventor: **Richard T. Gardner**, 204 N.
Charleston Rd., Darlington, S.C. 29540

Primary Examiner—Melody N. Brown
Attorney, Agent, or Firm—James A. Hudak

[**] Term: **14 Years**

[57] CLAIM

[21] Appl. No.: **46,083**

The ornamental design for a truck bed insert permitting retrieval of goods within truck bed, as shown and described.

[22] Filed: **Nov. 7, 1995**

DESCRIPTION

[51] LOC (6) Cl. **12-08**

[52] U.S. Cl. **D12/98**

[58] Field of Search D12/98, 414, 196;
414/515; 296/50, 55, 57.1, 60; 410/129,
142, 144

FIG. 1 is a perspective view of the truck bed insert permitting retrieval of goods within truck bed showing my new design;

FIG. 2 is a front elevational view thereof;

FIG. 3 is a rear elevational view thereof;

FIG. 4 is a right side elevational view thereof, the left side elevational view being a mirror image of the view shown in this Figure;

FIG. 5 is a top plan view thereof;

FIG. 6 is a bottom plan view thereof; and,

FIG. 7 is a perspective view of the truck bed insert installed in a truck bed.

The broken line illustration in FIG. 7 represents a truck bed and a portion of a truck and is not part of the design sought to be patented.

[56] References Cited

U.S. PATENT DOCUMENTS

D. 300,734	4/1989	Kruitbasch	D12/414
D. 306,003	2/1990	Berkan, Jr.	D12/414
D. 343,809	2/1994	Cannon	D12/98
D. 348,421	7/1994	Dexter	D12/98
D. 365,323	12/1995	Nopierkowski et al.	D12/414
1,538,464	5/1925	Chich	414/521
2,512,339	6/1950	Knapp, Jr.	414/515
4,685,856	8/1987	Hesse, Jr.	414/515
4,717,298	1/1988	Bott	410/129

1 Claim, 4 Drawing Sheets

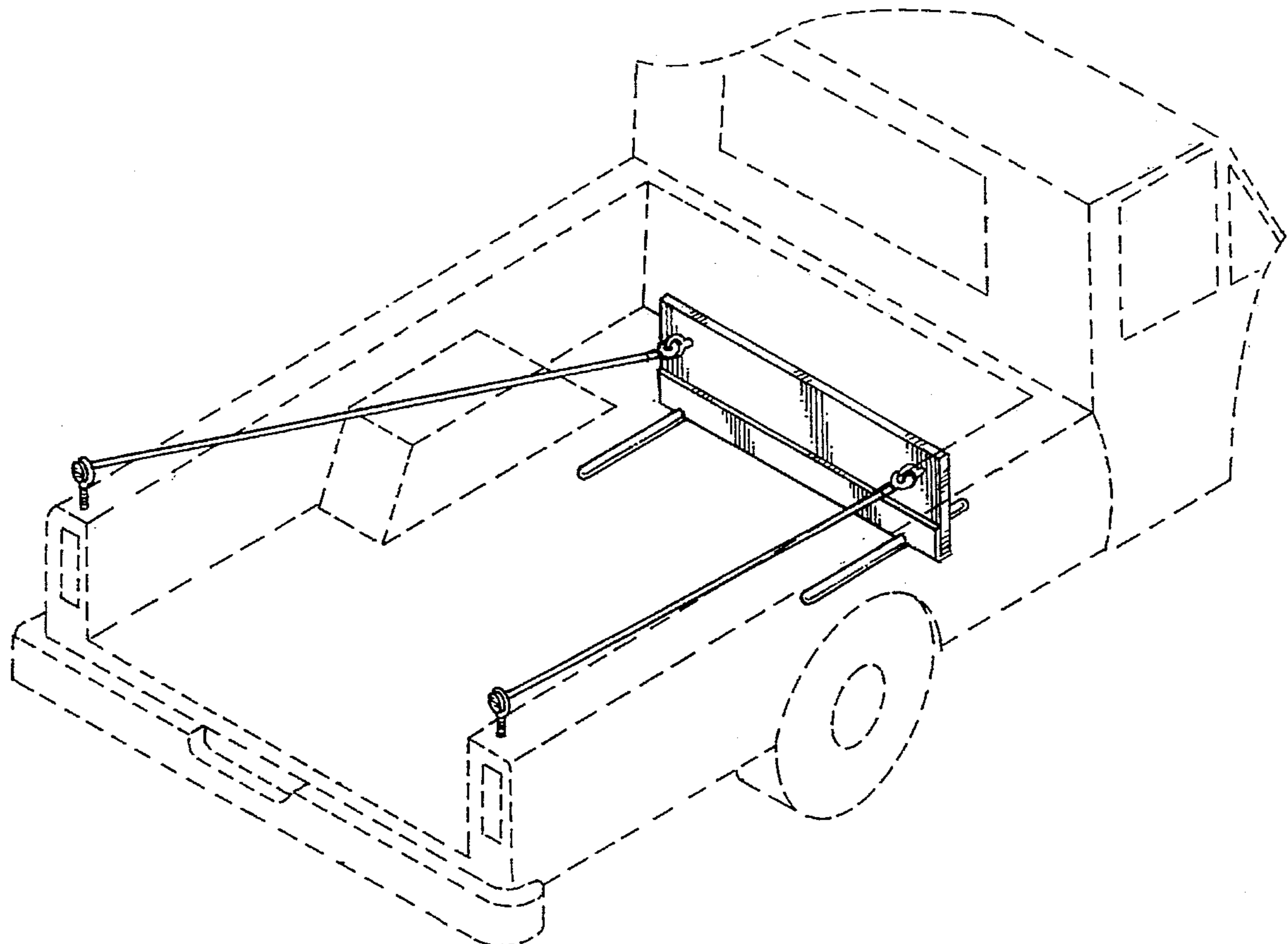

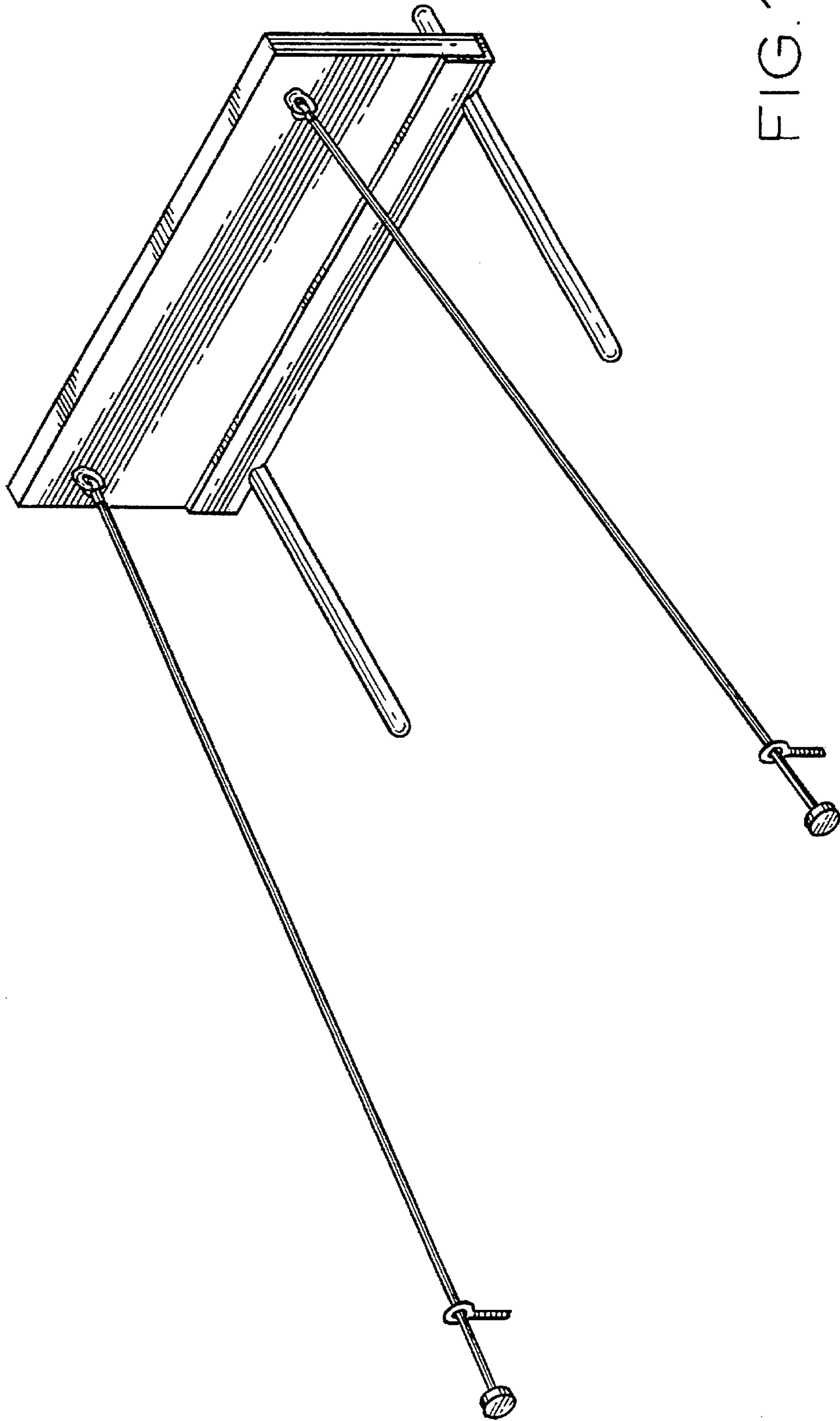

FIG. 1

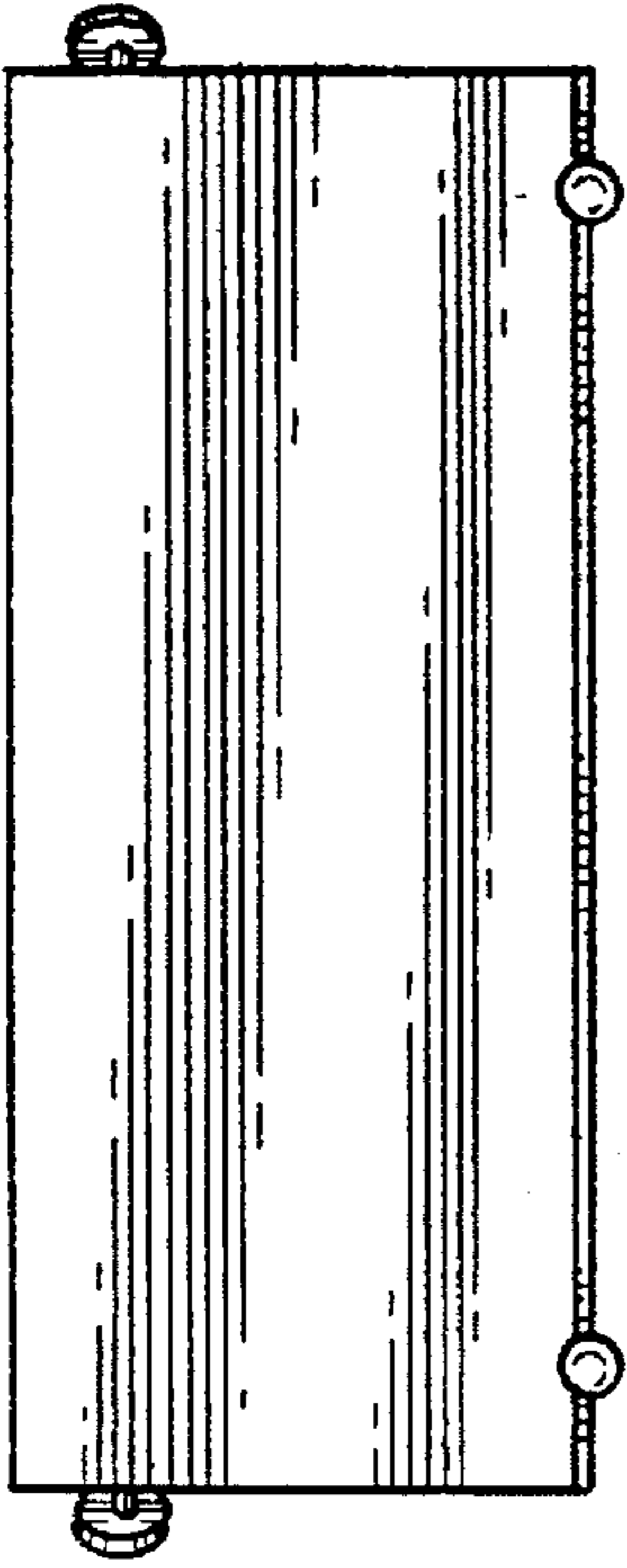

FIG. 3

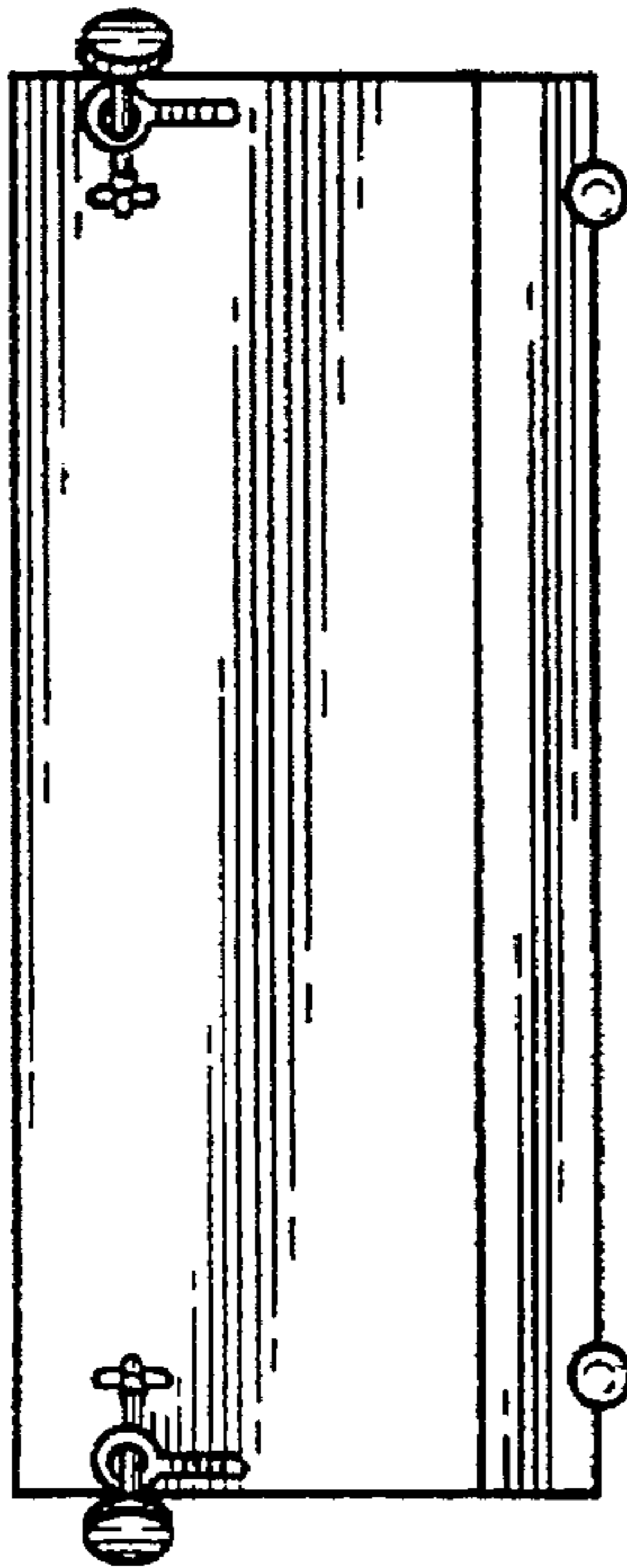

FIG. 2

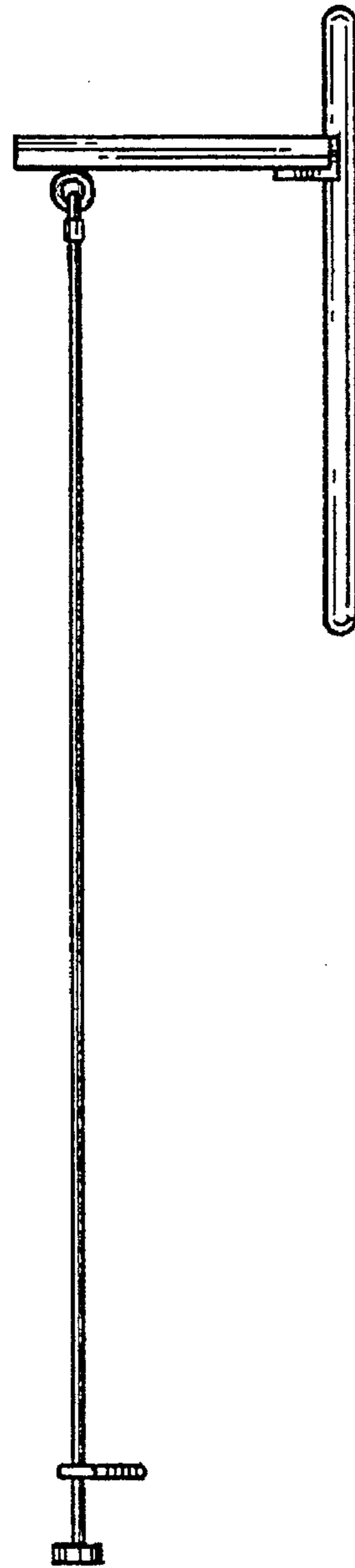

FIG. 4

FIG. 5

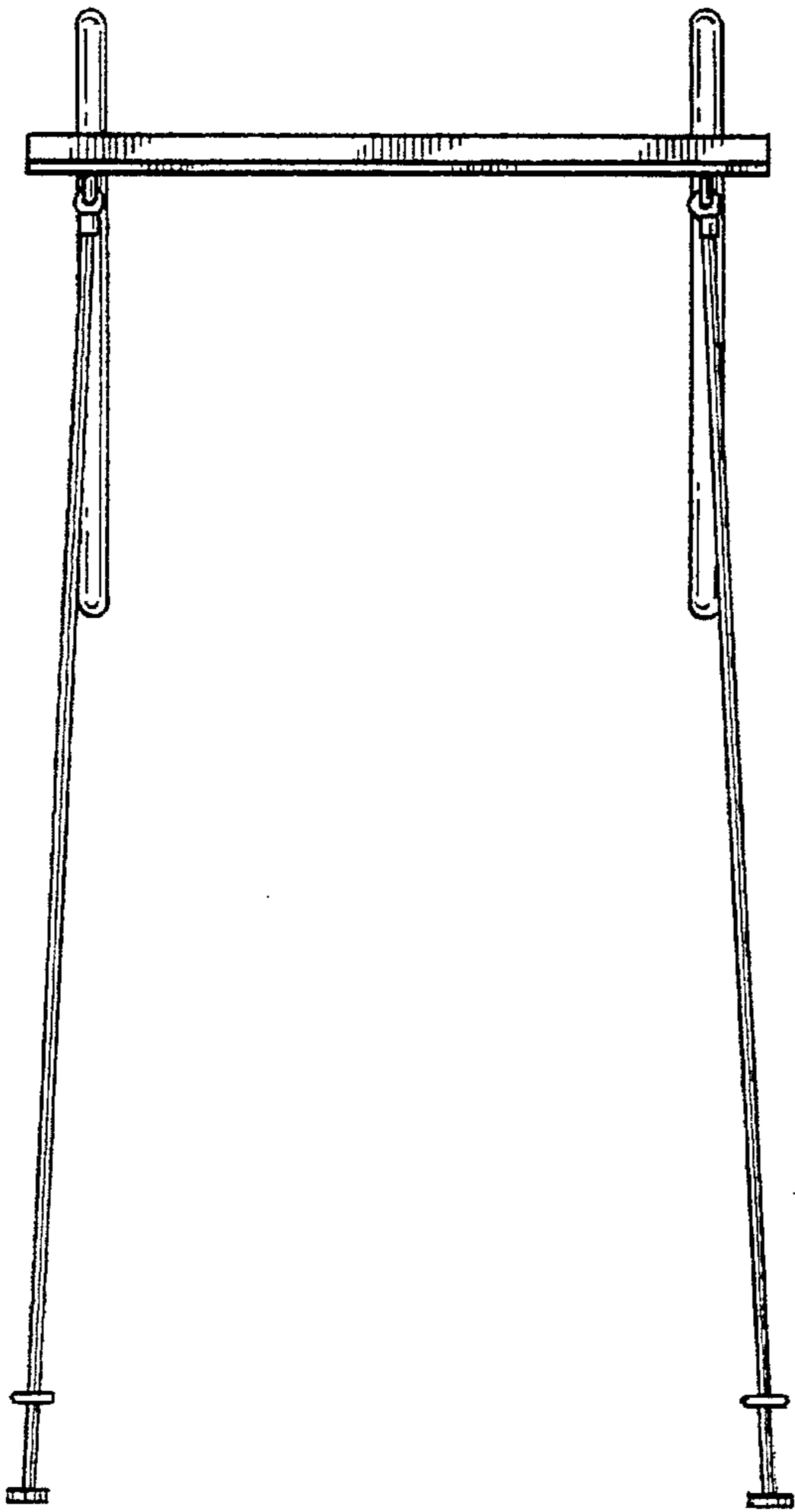
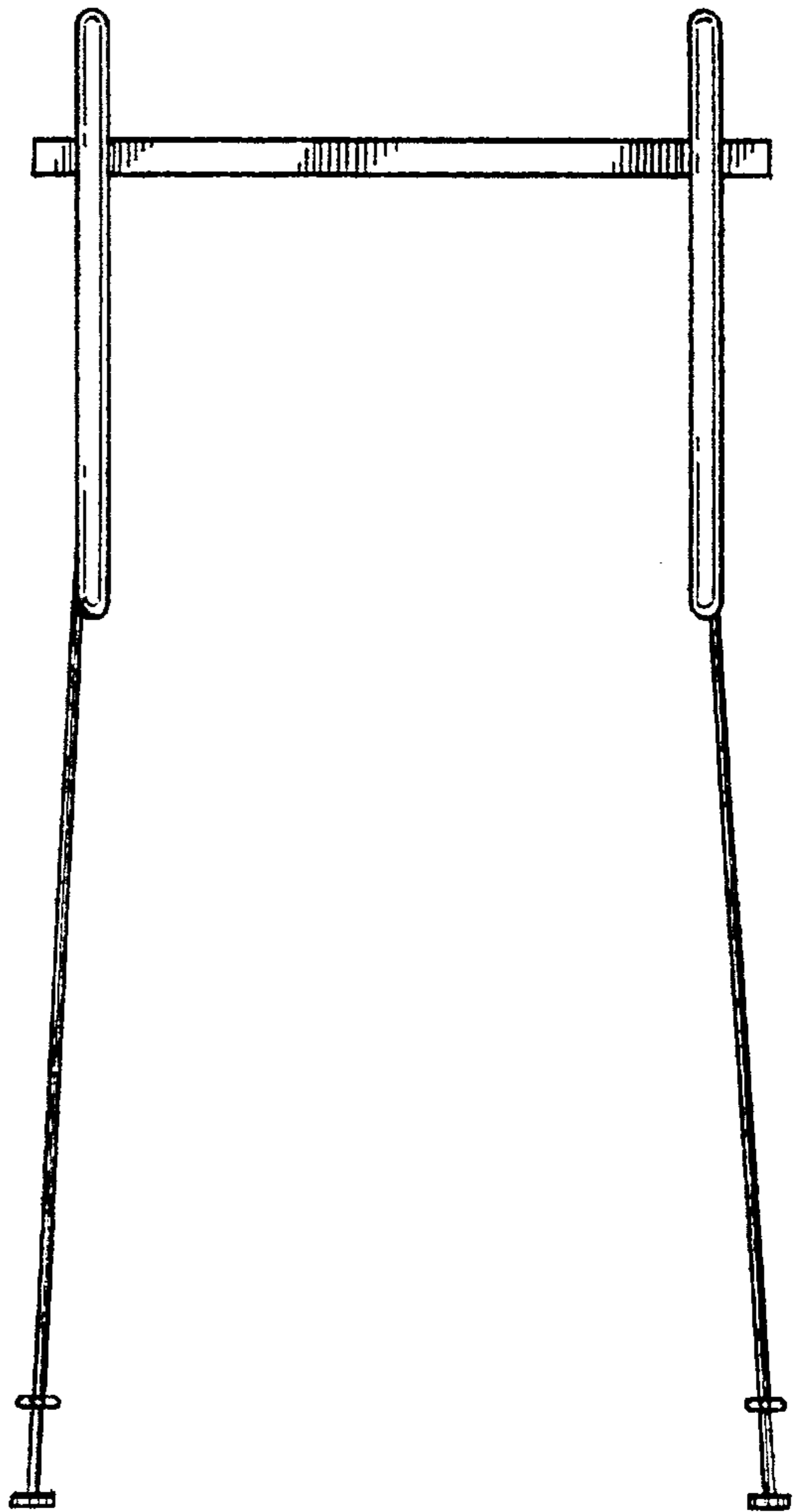

FIG. 6



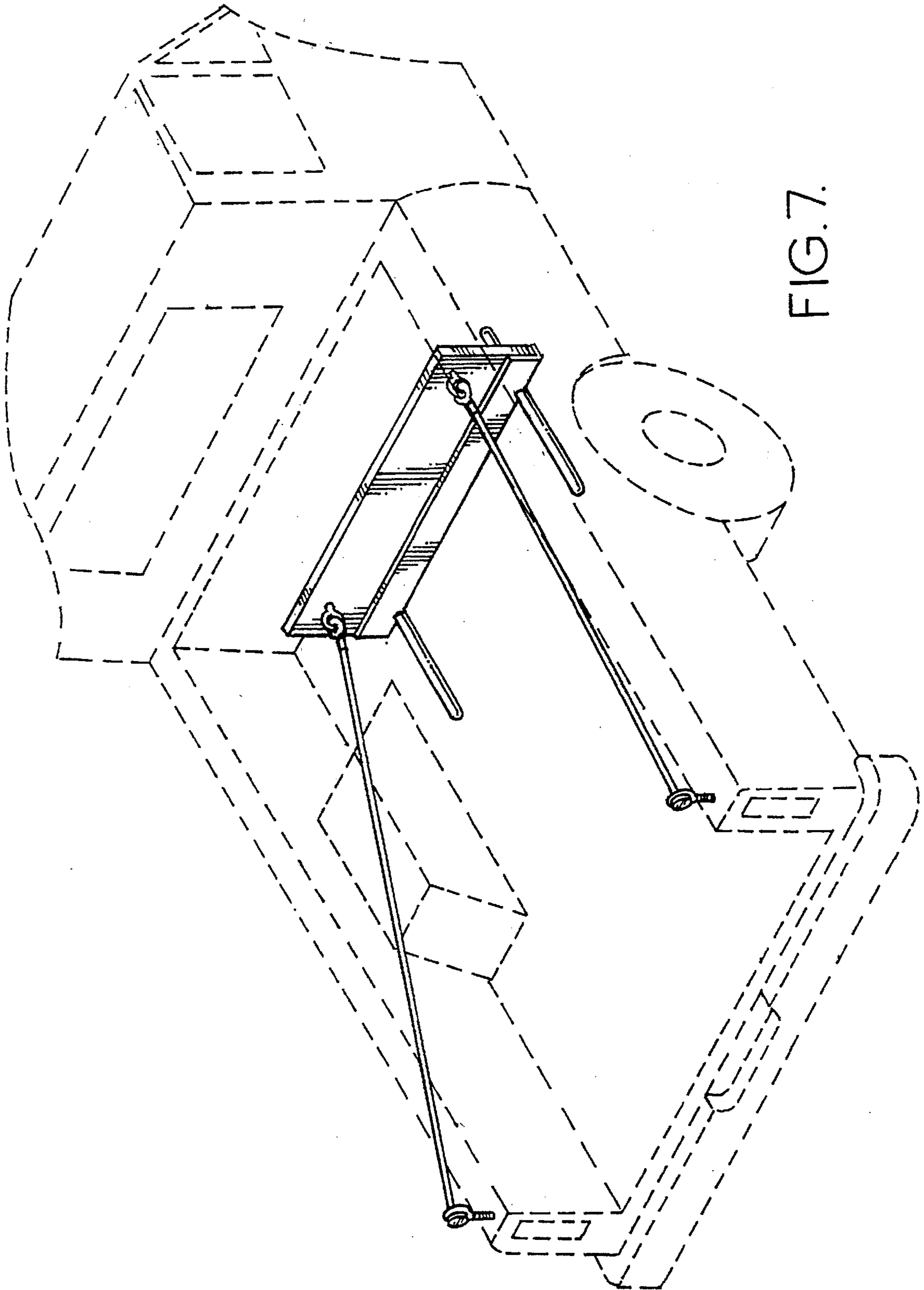

FIG. 7.