



US00D380440S

# United States Patent [19]

[11] Patent Number: **Des. 380,440**

Talish et al.

[45] Date of Patent: **\*\*Jul. 1, 1997**

## [54] ULTRASONIC TRANSDUCER HOUSING

[75] Inventors: **Roger J. Talish**, Fairfield; **Kenneth J. Urgovitch**, Clifton; **Kenneth J. Scowen**, Springfield; **John P. Ryaby**, Essex Fells, all of N.J.

[73] Assignee: **Exogen, Inc.**, Piscataway, N.J.

[\*\*] Term: **14 Years**

[21] Appl. No.: **34,813**

[22] Filed: **Feb. 13, 1995**

[51] LOC (6) Cl. .... **13-02**

[52] U.S. Cl. .... **D13/101**

[58] Field of Search ..... **D13/101; D8/307, D8/312, 313; D23/250; 73/629, 632, 639, 703**

## [56] References Cited

### U.S. PATENT DOCUMENTS

D. 127,735	6/1941	Dreyfuss	.....	D23/250
D. 187,847	5/1960	Kohler	.....	D23/250
D. 187,849	5/1960	Kohler	.....	D23/250
D. 200,186	1/1965	Kelly	.....	D23/250
D. 268,517	4/1983	Thompson	.....	D8/307 X
D. 338,187	8/1993	Barrett, Jr.	.....	D13/101

Primary Examiner—Joel Sincavage

Attorney, Agent, or Firm—Dilworth & Barrese

## [57] CLAIM

The ornamental design for an ultrasonic transducer housing, as shown and described.

## DESCRIPTION

FIG. 1 is a perspective view of an ultrasonic transducer housing, showing my new design;

FIG. 2 is a top plan view of the ultrasonic transducer housing as seen from above FIG. 1;

FIG. 3 is a side view of the ultrasonic transducer housing as seen from the left of FIG. 1;

FIG. 4 is a bottom plan view of the ultrasonic transducer housing as seen from below FIG. 1;

FIG. 5 is a perspective view of my ultrasonic transducer housing, showing another variation of my new design;

FIG. 6 is a top plan view of the ultrasonic transducer housing as seen from above FIG. 5;

FIG. 7 is a side view of the ultrasonic transducer housing as seen from the left of FIG. 5;

FIG. 8 is a bottom plan view of the ultrasonic transducer housing as seen from below FIG. 5;

FIG. 9 is a perspective view of my ultrasonic transducer housing, showing another variation of my new design;

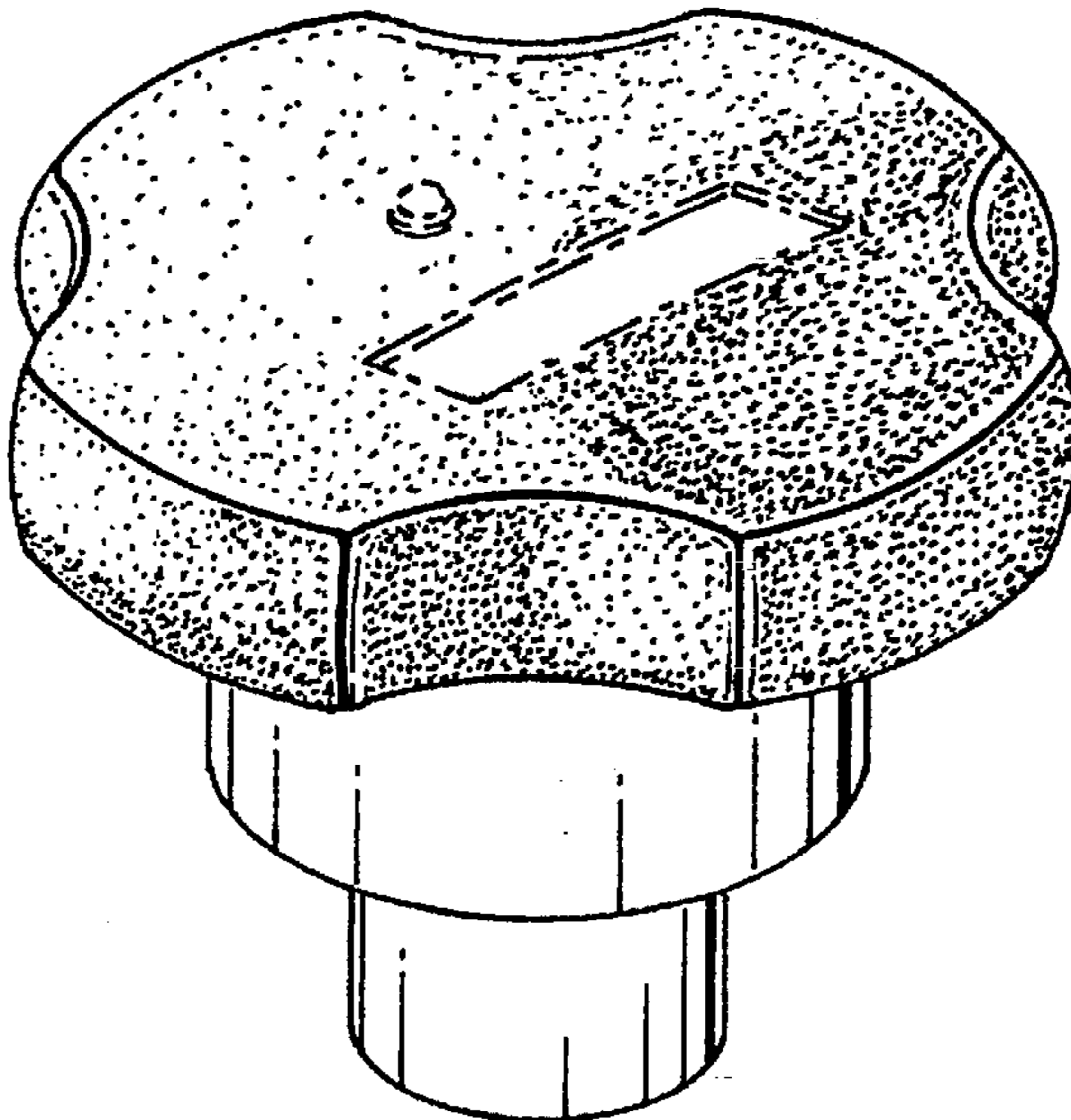
FIG. 10 is a top plan view of the ultrasonic transducer housing as seen from above FIG. 9;

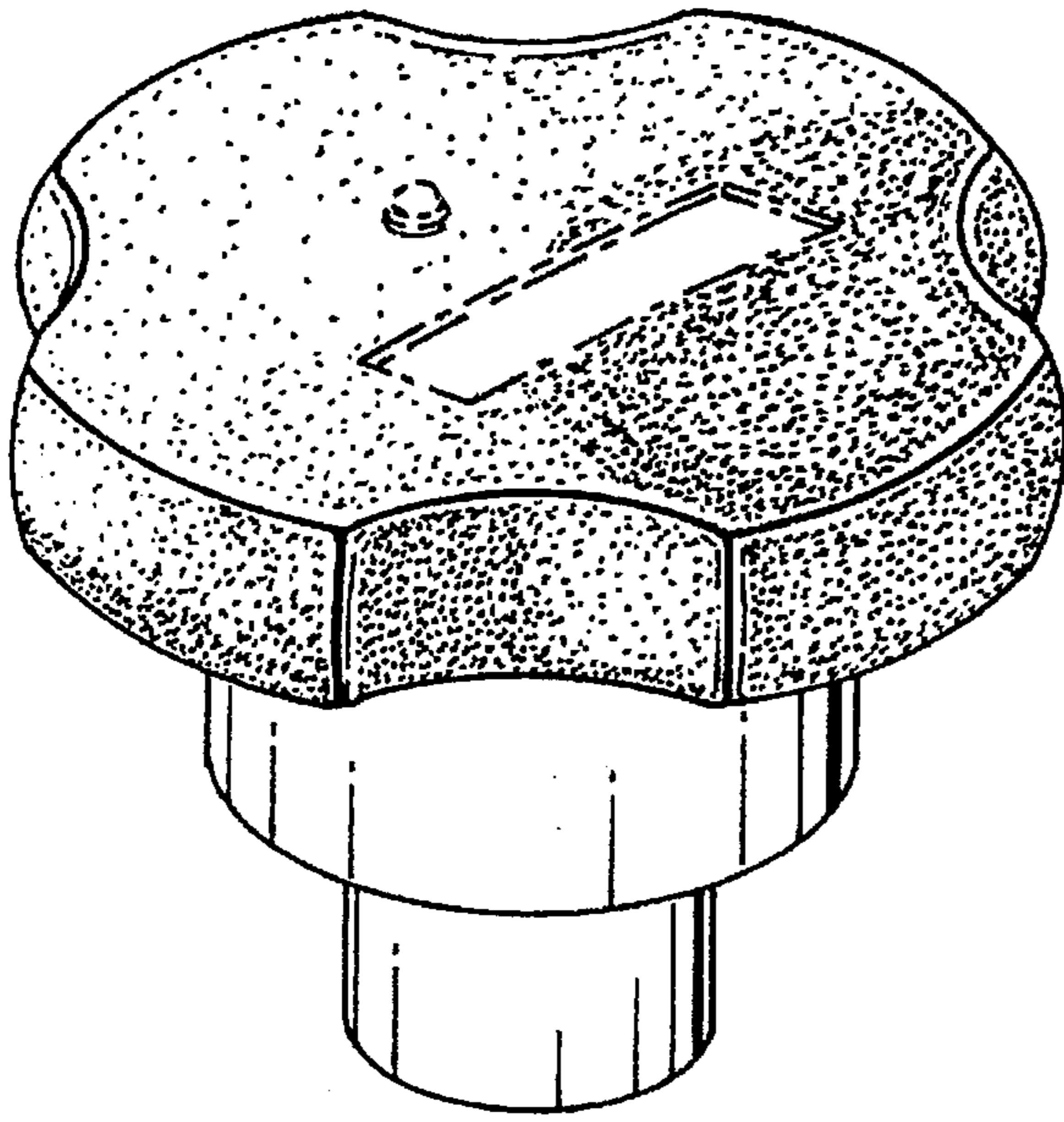
FIG. 11 is a side view of the ultrasonic transducer housing as seen from the left of FIG. 9; and,

FIG. 12 is a bottom plan view of the ultrasonic transducer housing as seen from below FIG. 9.

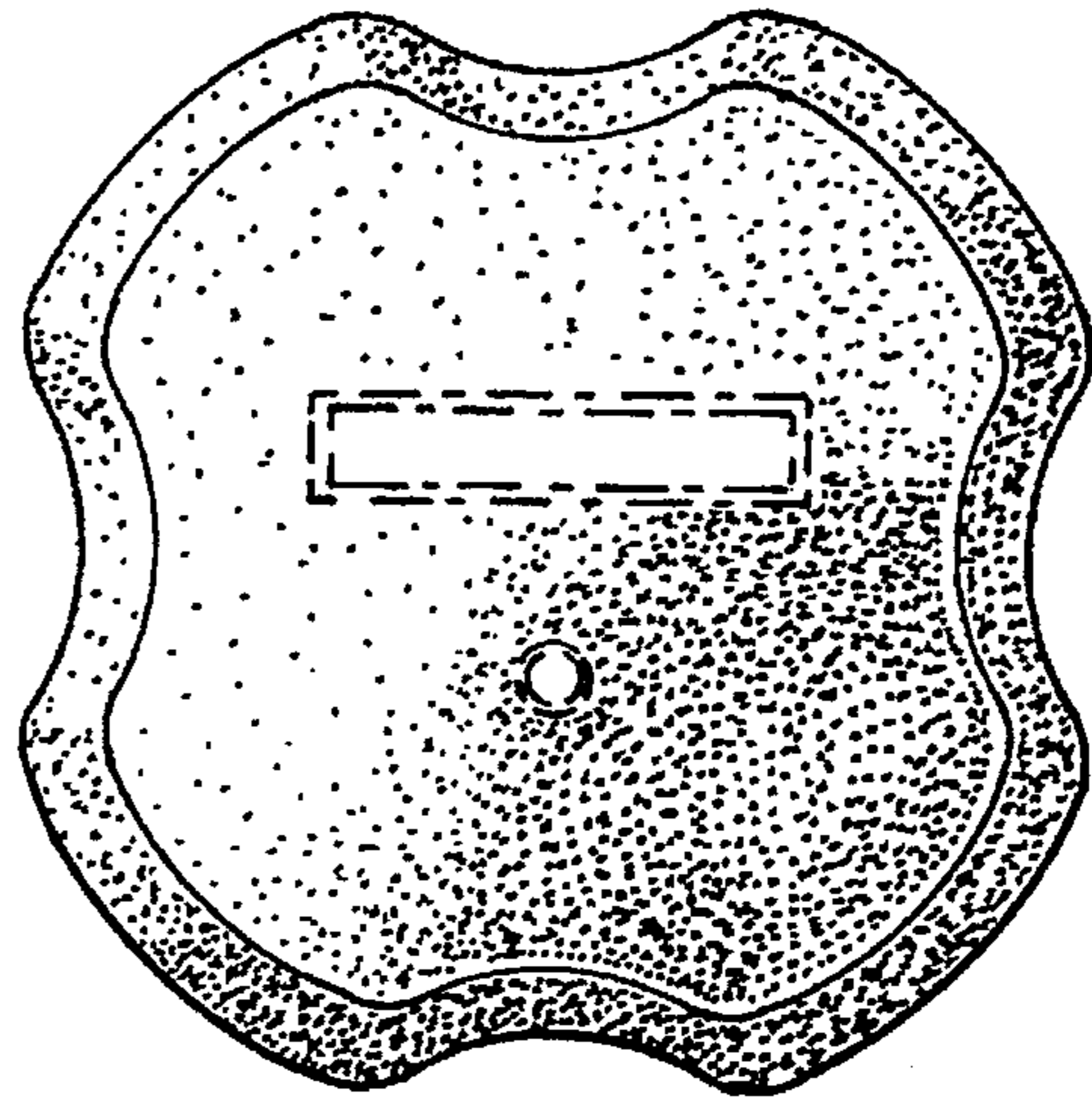
The broken line showing throughout the drawing figures is included for the purpose of illustrating environmental structure only and forms no part of the claimed design.

1 Claim, 3 Drawing Sheets

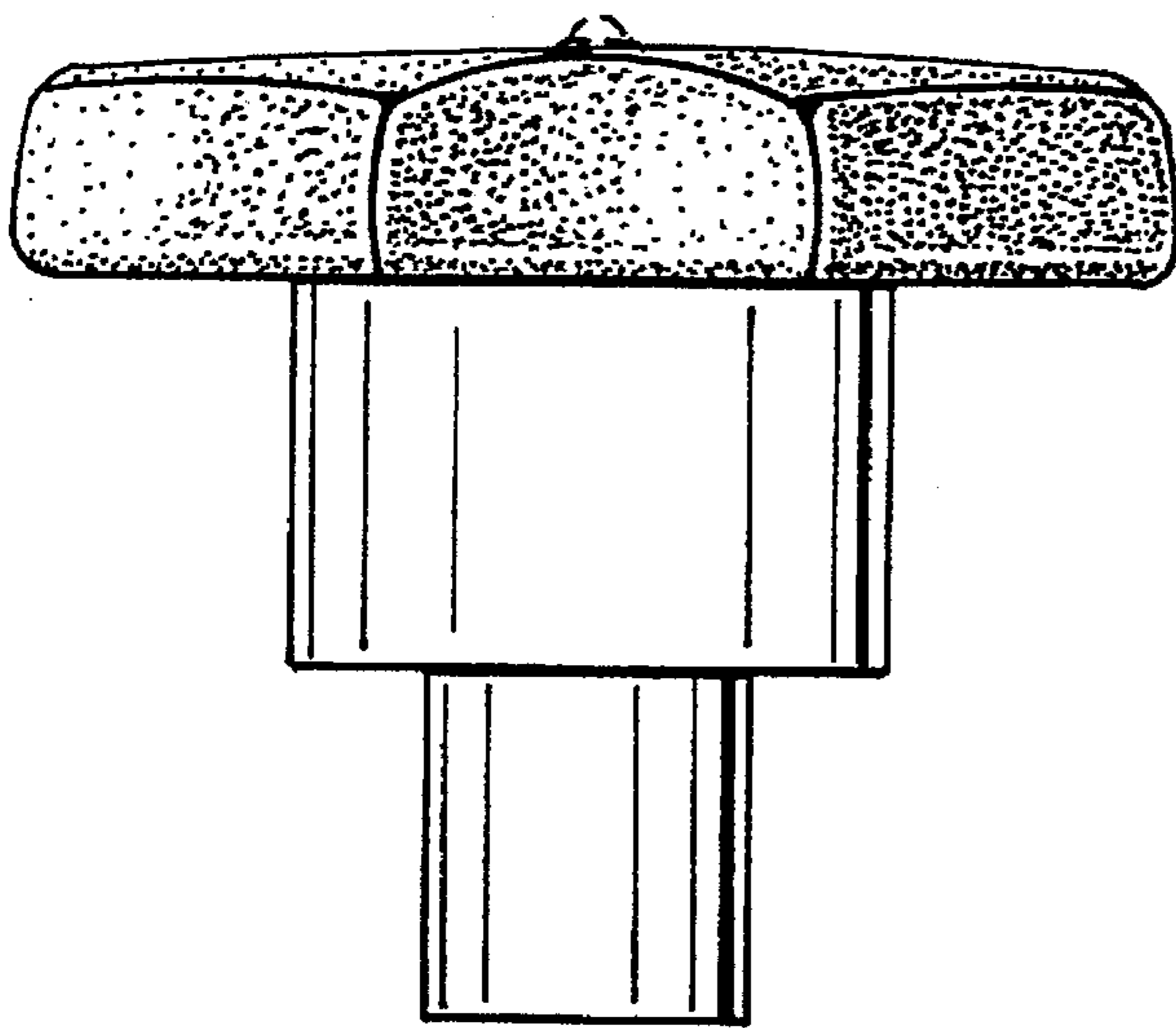




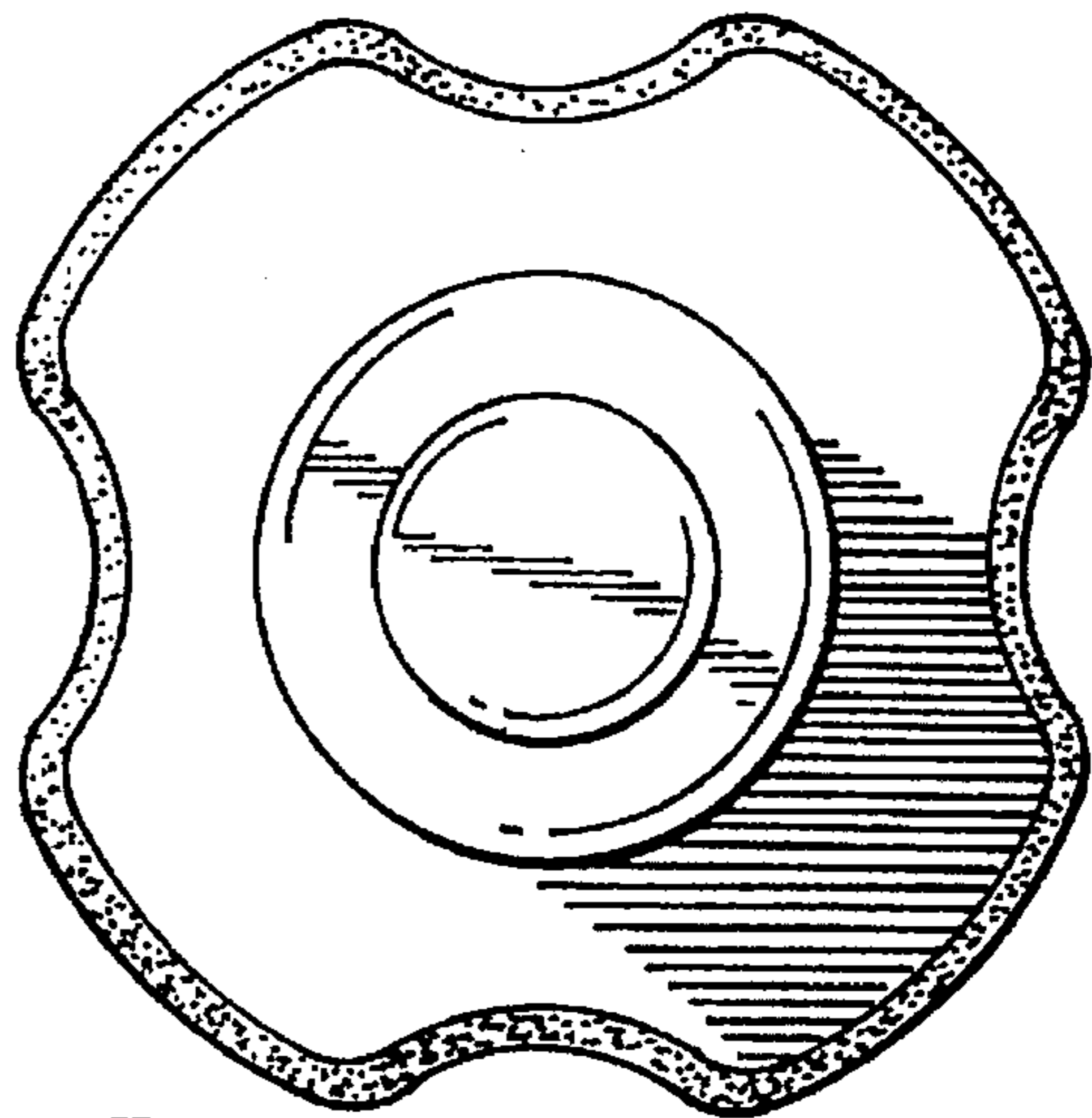
**Fig. 1**



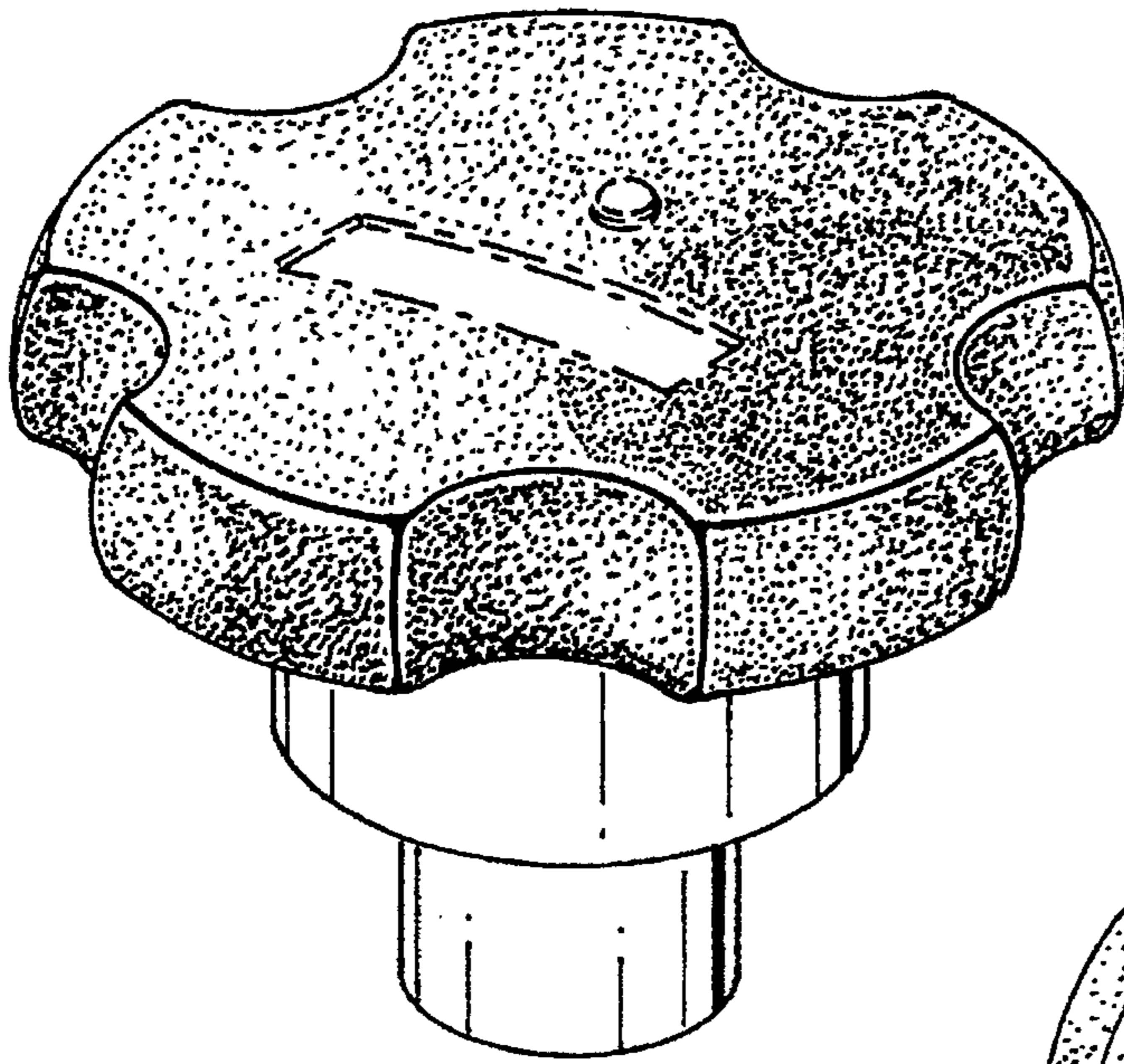
**Fig. 2**



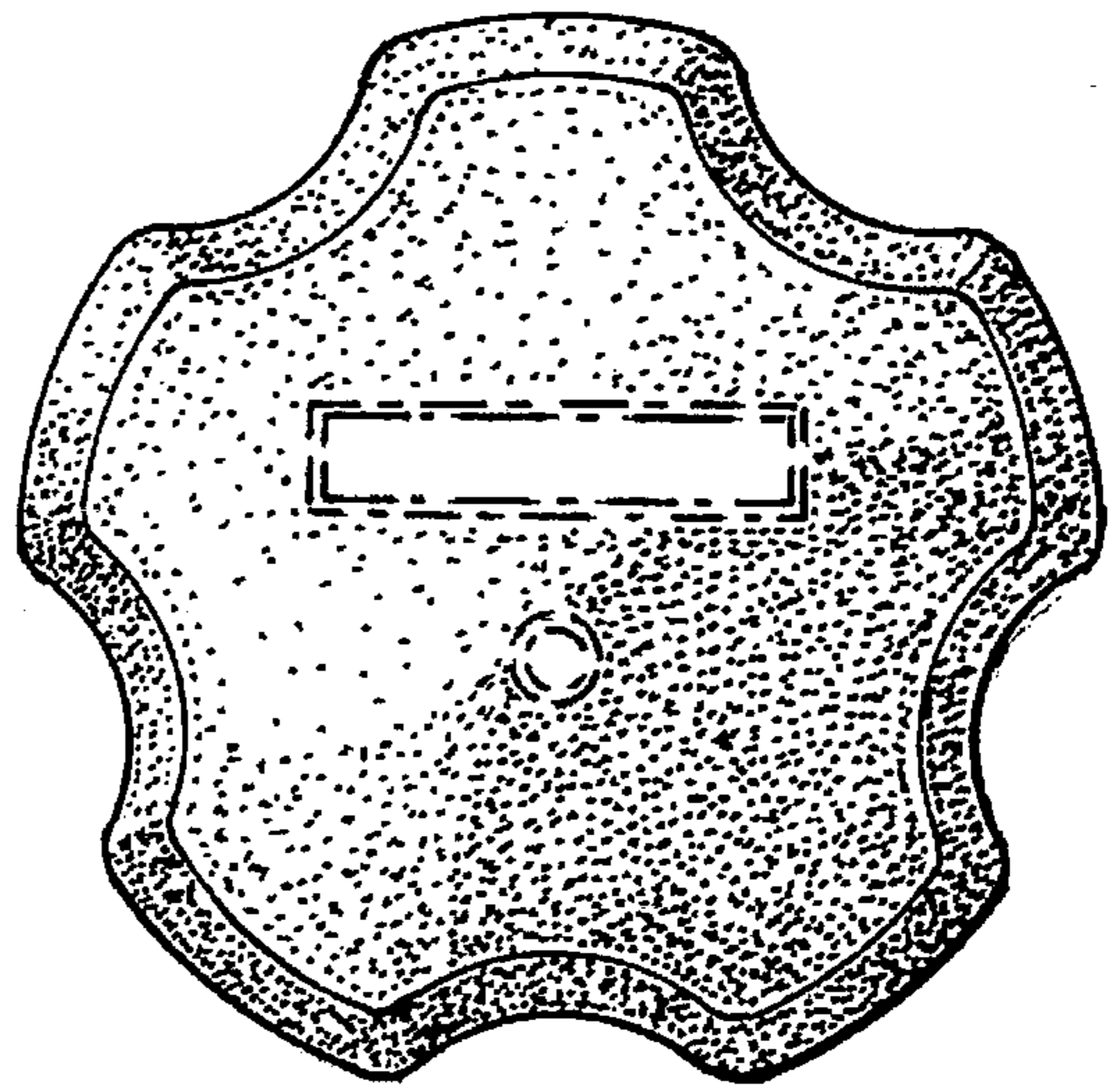
**Fig. 3**



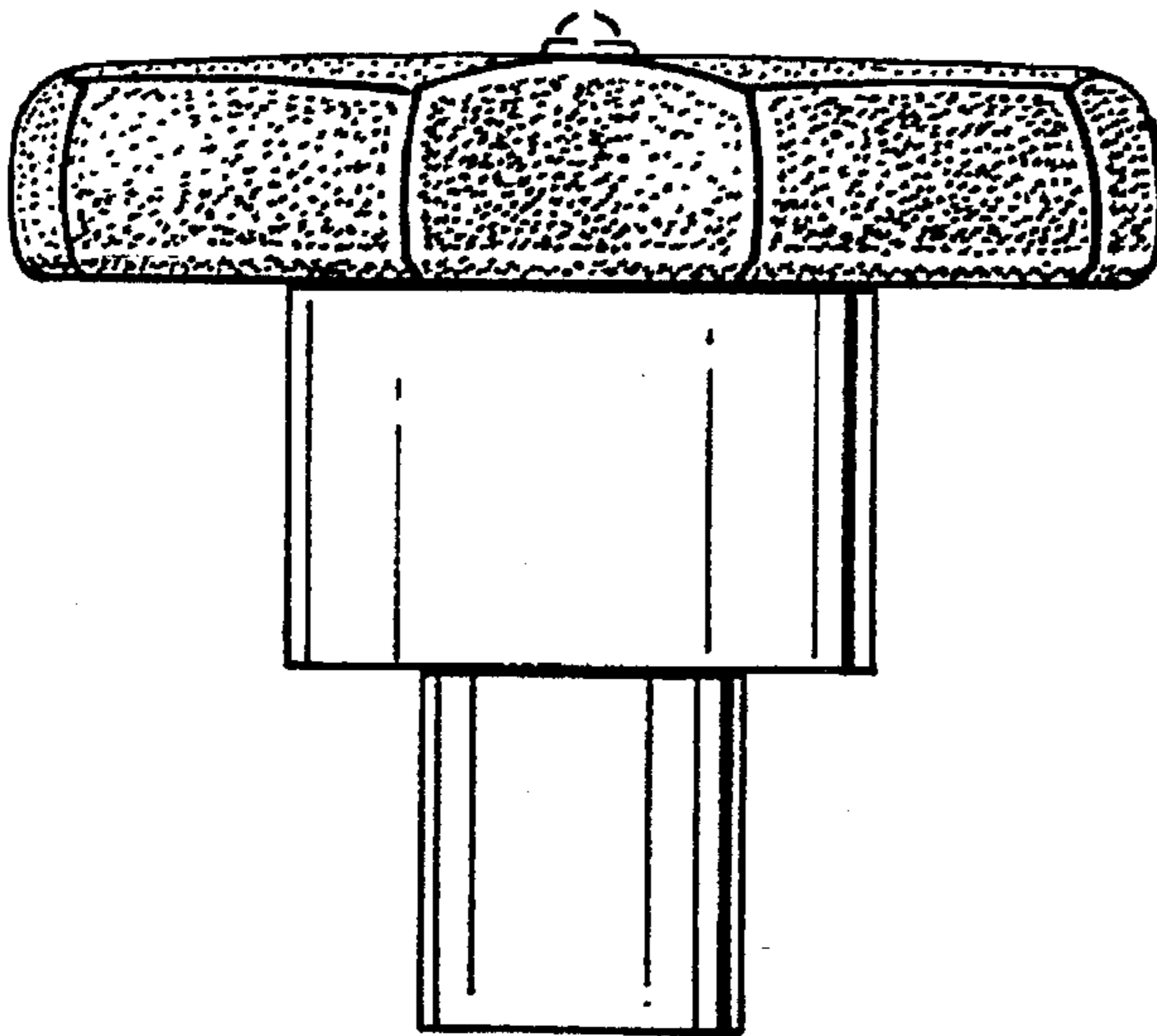
**Fig. 4**



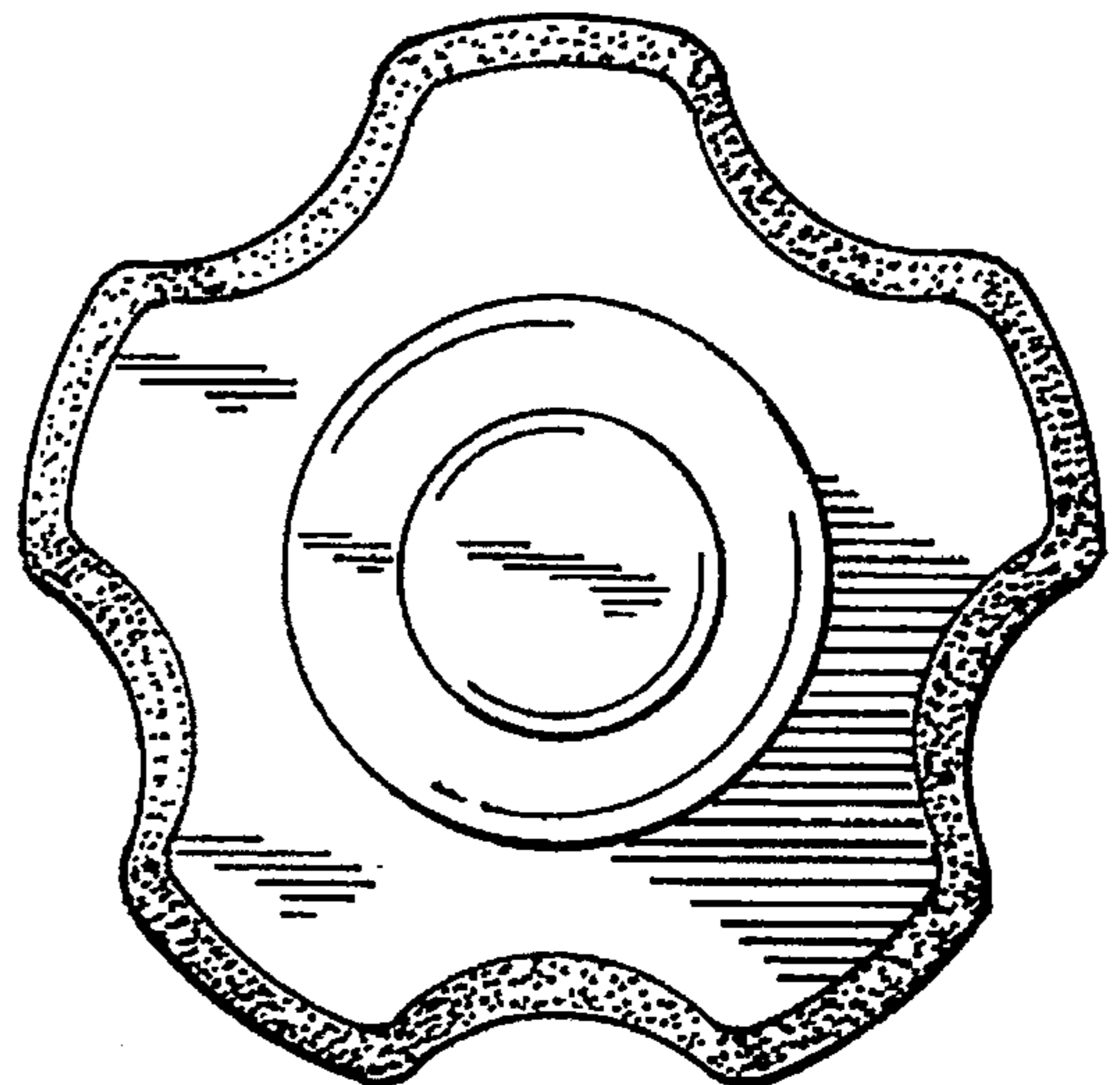
**Fig. 5**



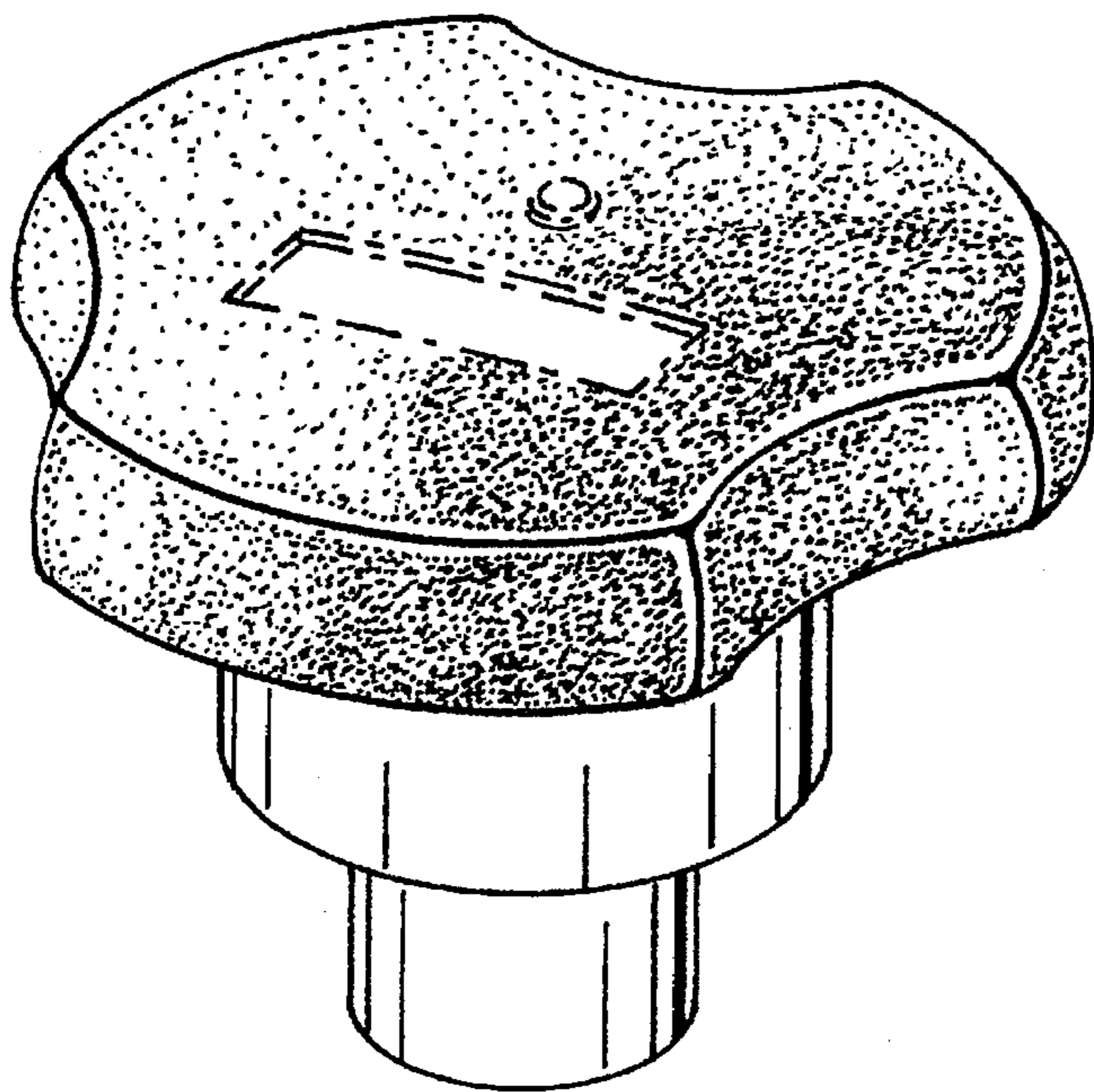
**Fig. 6**



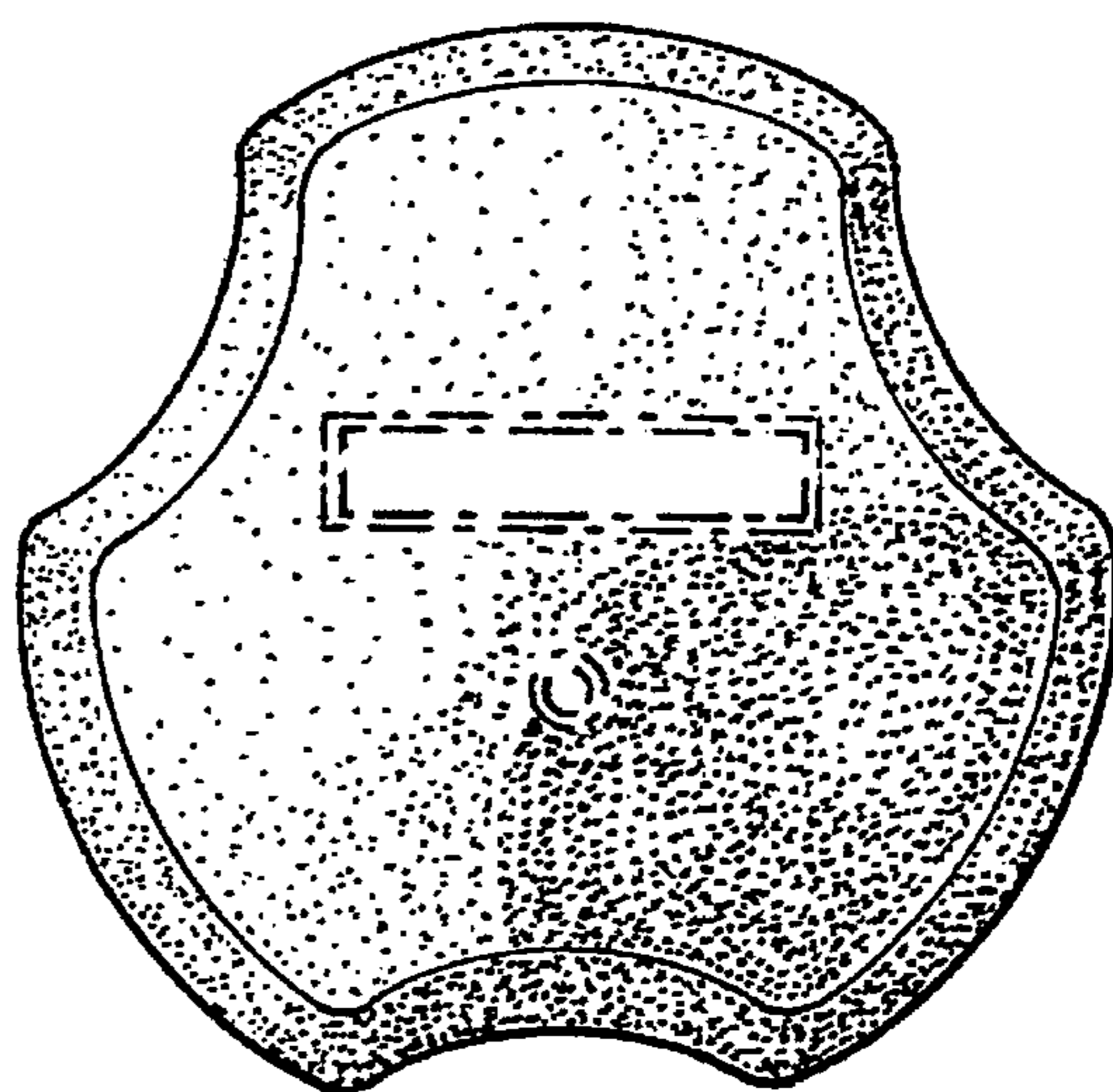
**Fig. 7**



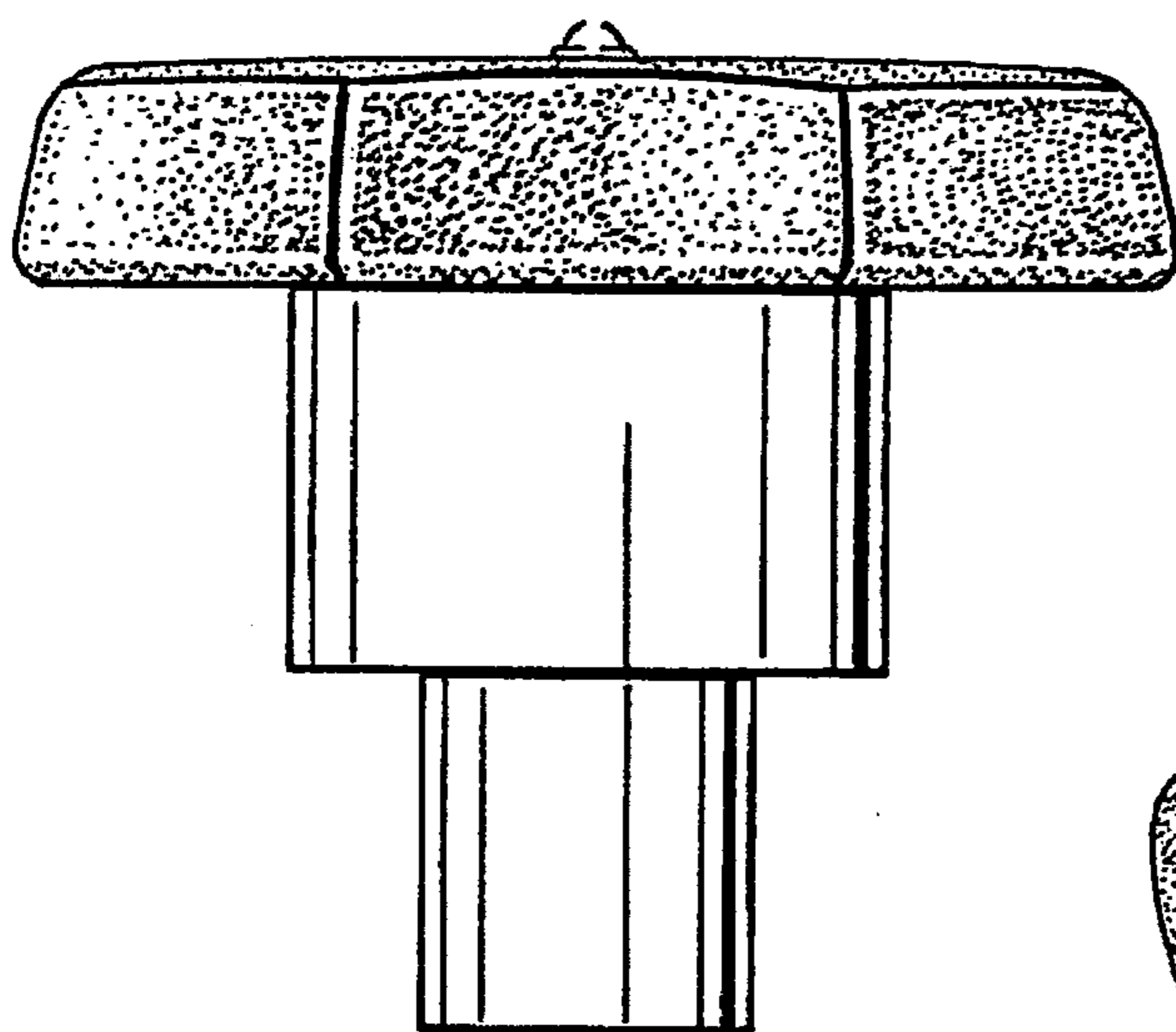
**Fig. 8**



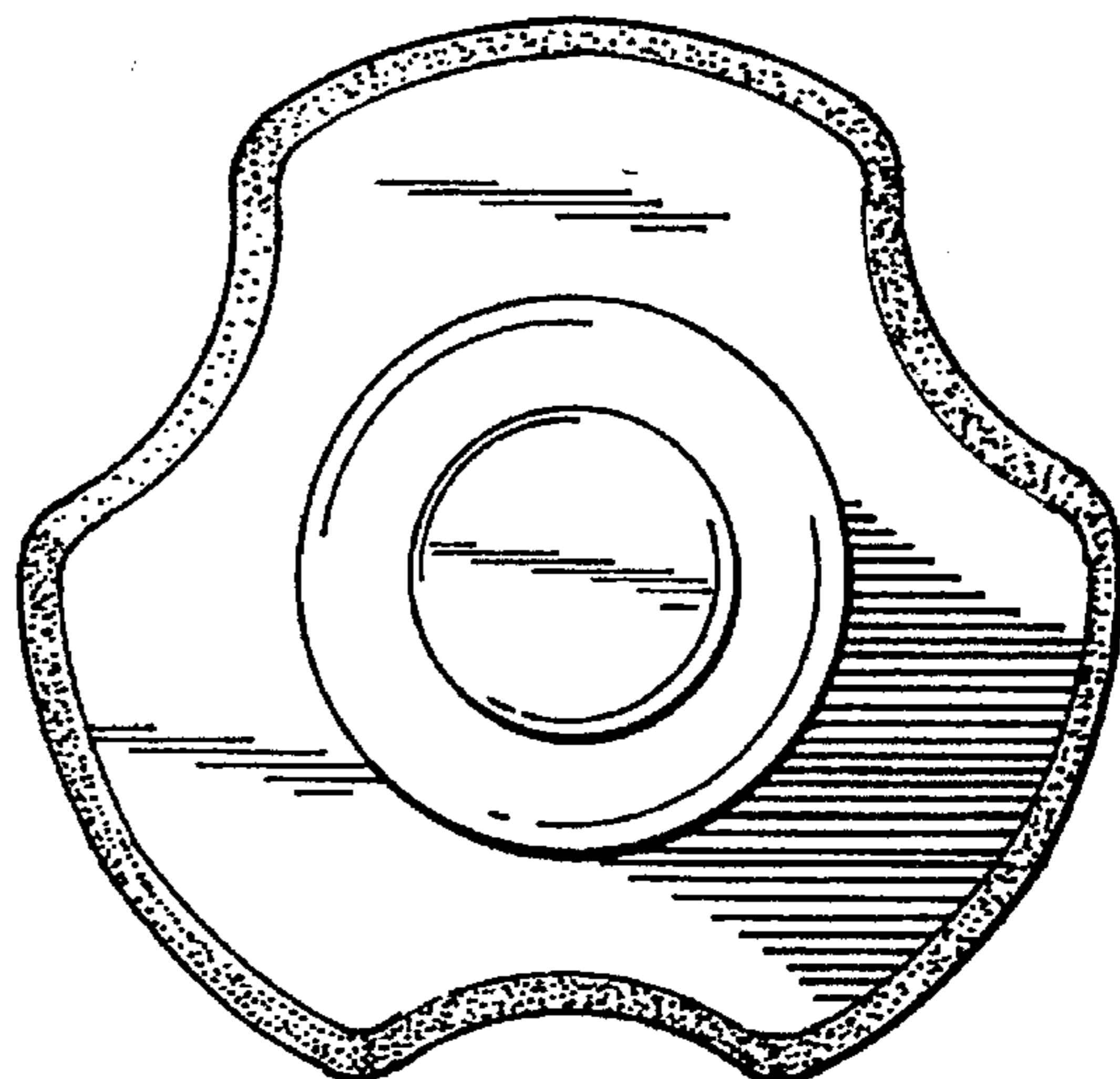
**Fig. 9**



**Fig. 10**



**Fig. 11**



**Fig. 12**