



US00D380419S

# United States Patent [19]

[11] Patent Number: Des. 380,419

Thompson et al.

[45] Date of Patent: \*\*Jul. 1, 1997

[54] SNOWMOBILE TRACK

[75] Inventors: **Mark B. Thompson**, Providence, Utah;  
**Serge A. Bedard**, Valcourt, Canada

[73] Assignee: **Bombardier Inc.**, Montreal, Canada

[\*\*] Term: **14 Years**

39841	3/1975	Canada .	
1117570	2/1982	Canada .	
1132169	9/1982	Canada .	
2014852	10/1990	Canada .	
2100105	1/1994	Canada .	
0047772	3/1985	Japan .....	305/35 EB
2104015	3/1985	United Kingdom .....	305/35 EB

[21] Appl. No.: **32,817**

[22] Filed: **Dec. 29, 1994**

[51] LOC (6) Cl. .... **12-14**

[52] U.S. Cl. .... **D12/7**

[58] Field of Search ..... D12/1, 7; D34/29,  
D34/35; D8/499; 305/35 EB, 24; D15/28

*Primary Examiner*—Holly Baynham  
*Attorney, Agent, or Firm*—Dorsey & Whitney LLP

## [57] CLAIM

The ornamental design for a snowmobile track, as shown and described.

## DESCRIPTION

FIG. 1 is a side elevation of a snowmobile track embodying our design, it being understood that the thread design continues uniformly through the belt indicated in light full lines;

FIG. 2 is a plan view, it being understood that the thread design continues uniformly through the belt indicated in light full lines;

FIG. 3 is a fragmentary perspective view to an enlarged scale showing a portion of the snowmobile track;

FIG. 4 is a cross-sectional view taken on the line 4—4 in FIG. 3;

FIG. 5 is a plan view corresponding to FIG. 4;

FIG. 6 is a sectional view taken on the line 6—6 in FIG. 5;

FIG. 7 is a view taken on the line 7—7 in FIG. 5;

FIG. 8 is an enlarged, fragmentary plan view of a second embodiment of the design shown in FIG. 1; and,

FIG. 9 is a side view with the opposite side being a mirror image.

The claimed design is shown broken away to indicate indeterminate length.

## [56] References Cited

### U.S. PATENT DOCUMENTS

D. 222,247	10/1971	Perreault .....	D12/7
D. 242,612	12/1976	Perreault .....	D12/7
D. 243,517	3/1977	Belanger .....	D12/7
D. 283,206	4/1986	Talbot .....	D12/7
D. 300,977	5/1989	Watanabe et al. ....	D12/1 X
3,165,364	1/1965	Hardman et al. ....	303/35 EB
3,355,225	11/1967	McDowell et al. .	
3,472,563	10/1969	Irgens .....	305/35 EB
3,619,012	11/1971	Bizier et al. .	
3,704,918	12/1972	Perreault .	
3,762,779	10/1973	Russ, Sr. .	
3,781,067	12/1973	Dodson et al. .	
3,857,617	12/1974	Grawley .	
5,005,922	4/1991	Edwards et al. .	

### FOREIGN PATENT DOCUMENTS

217455	4/1922	Canada .
898862	4/1972	Canada .
949624	6/1974	Canada .

1 Claim, 4 Drawing Sheets

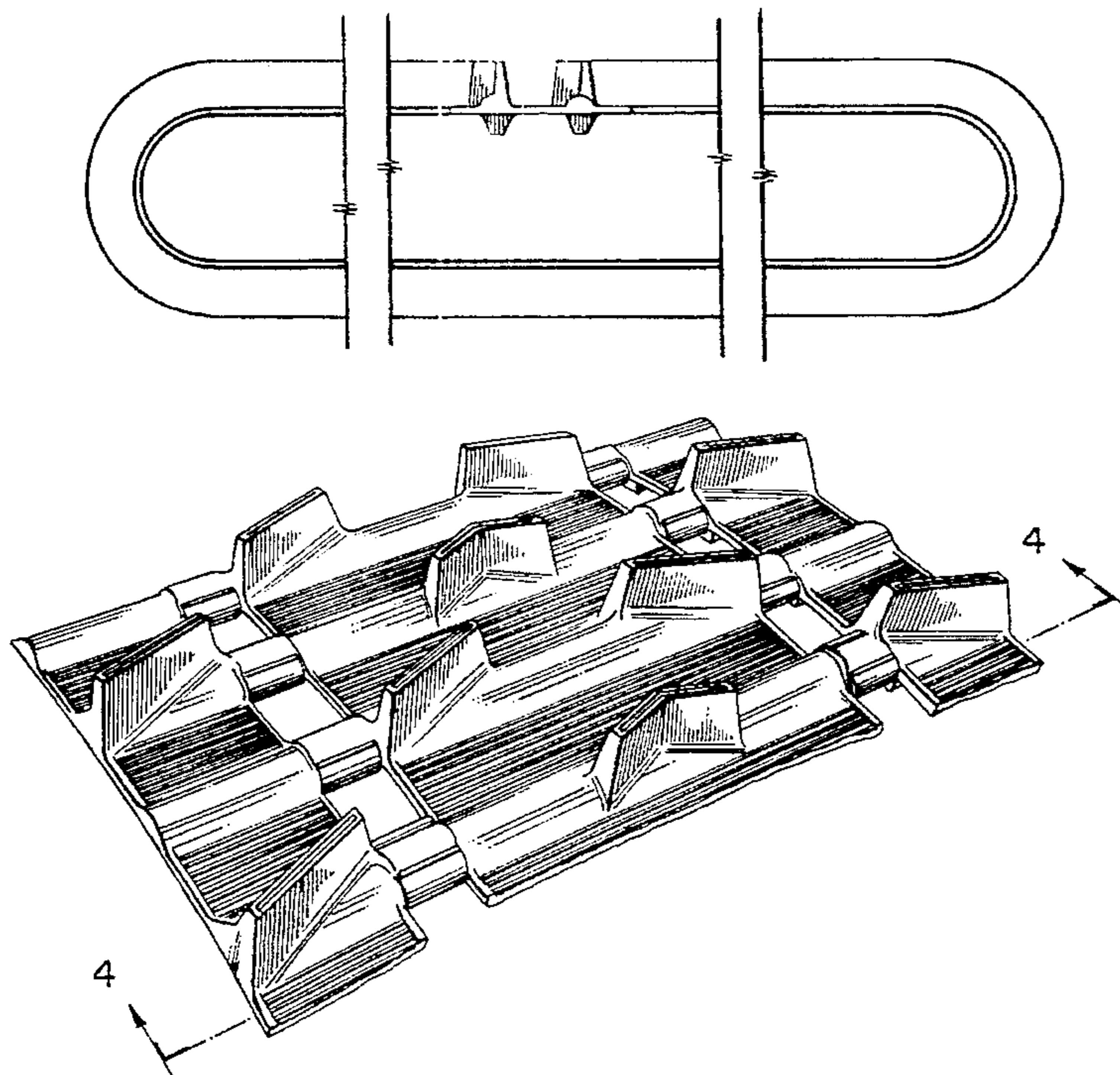

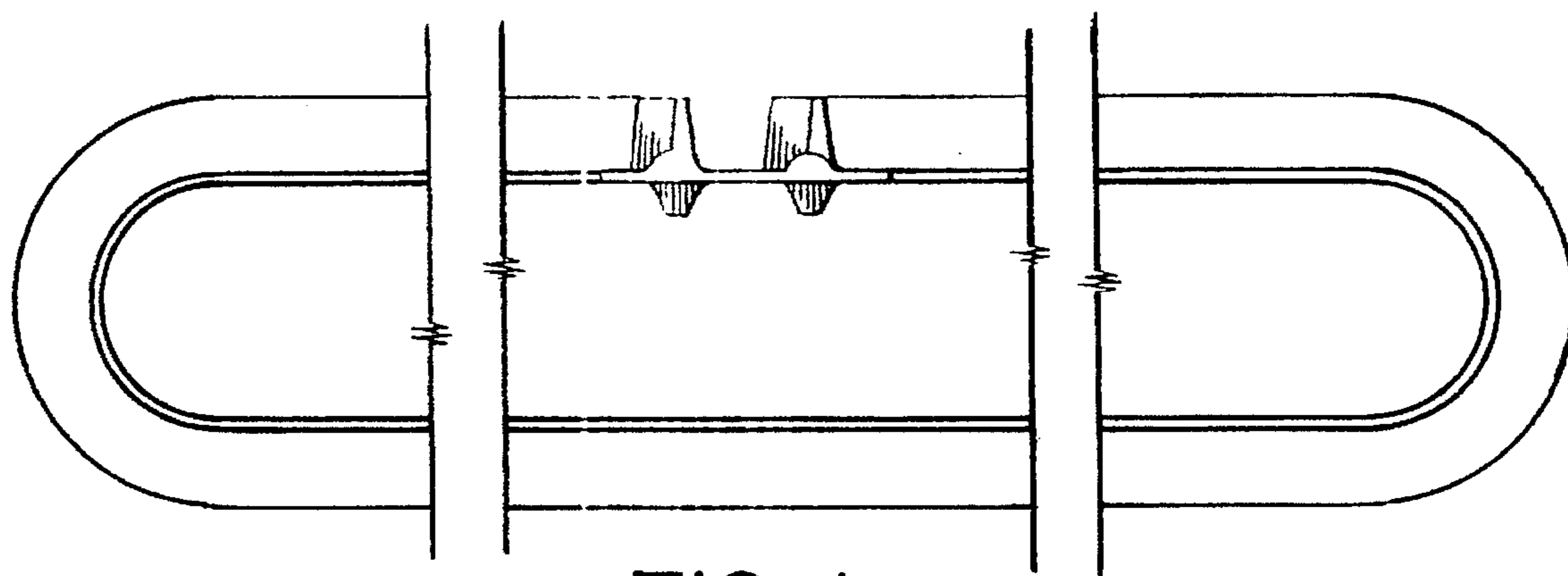

FIG. 1

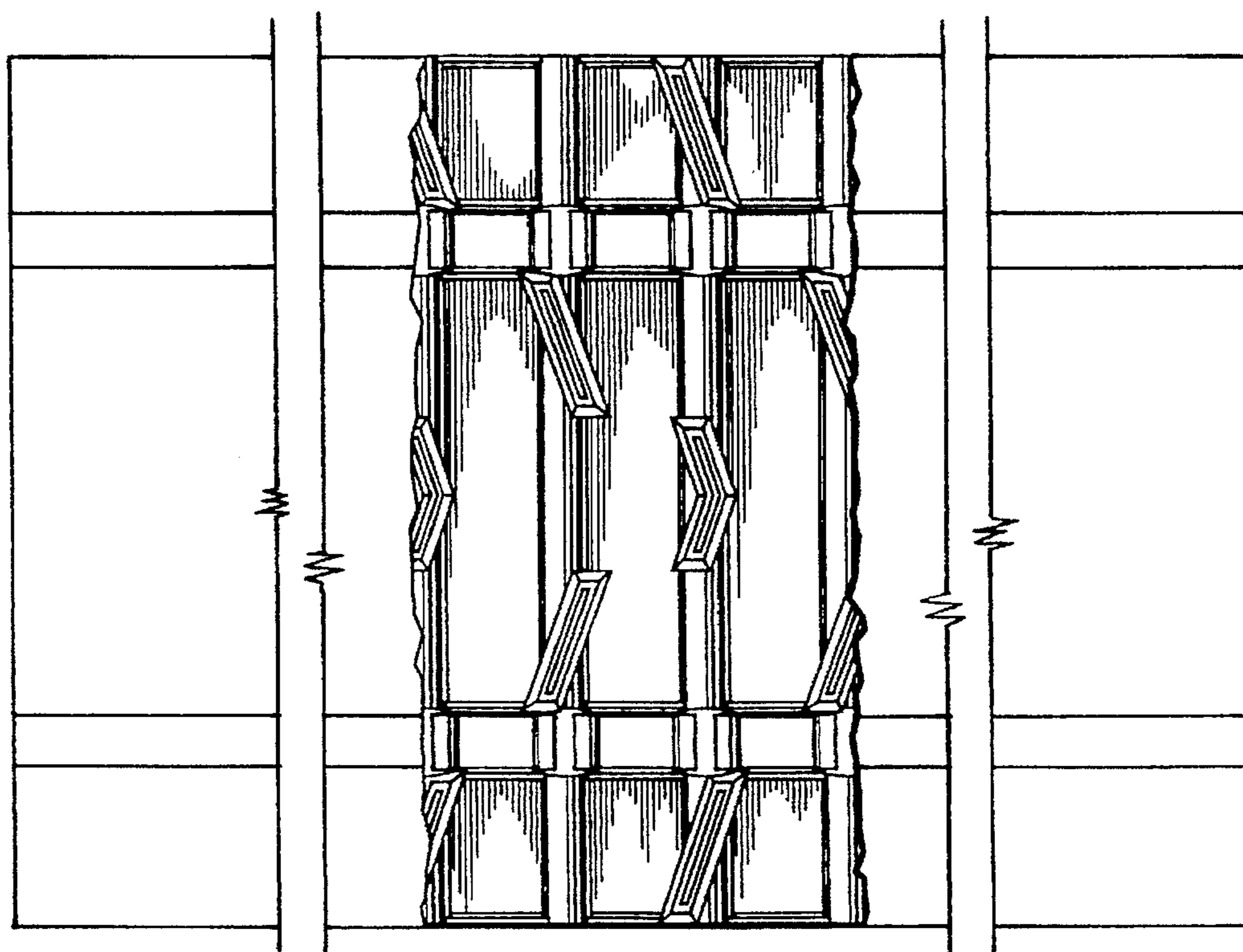

FIG. 2

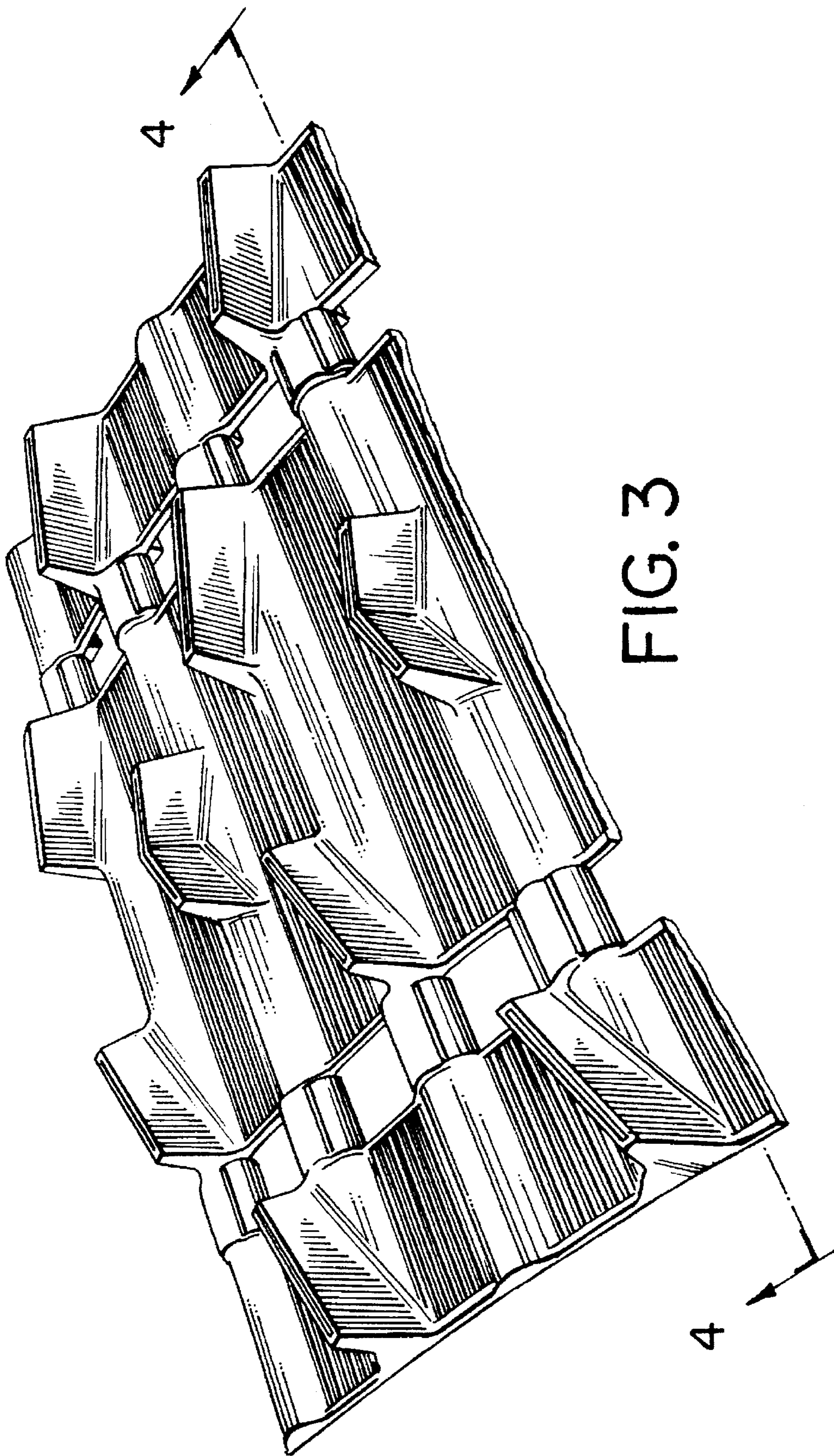

FIG. 3

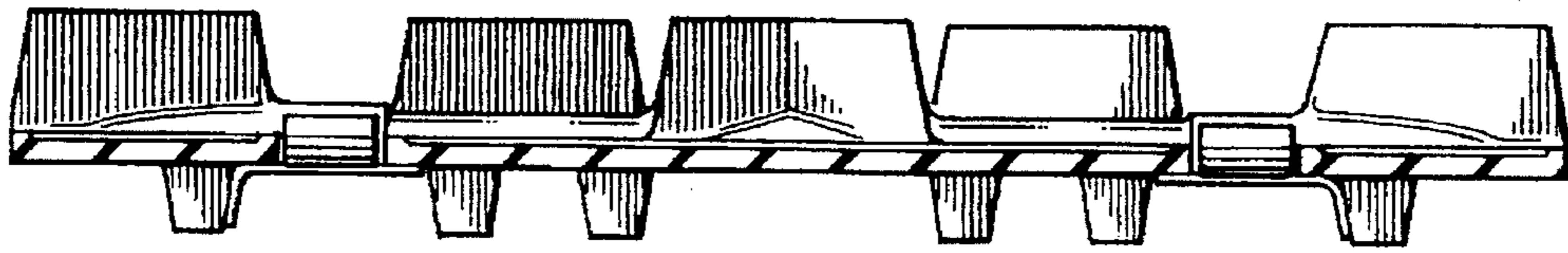

FIG. 4

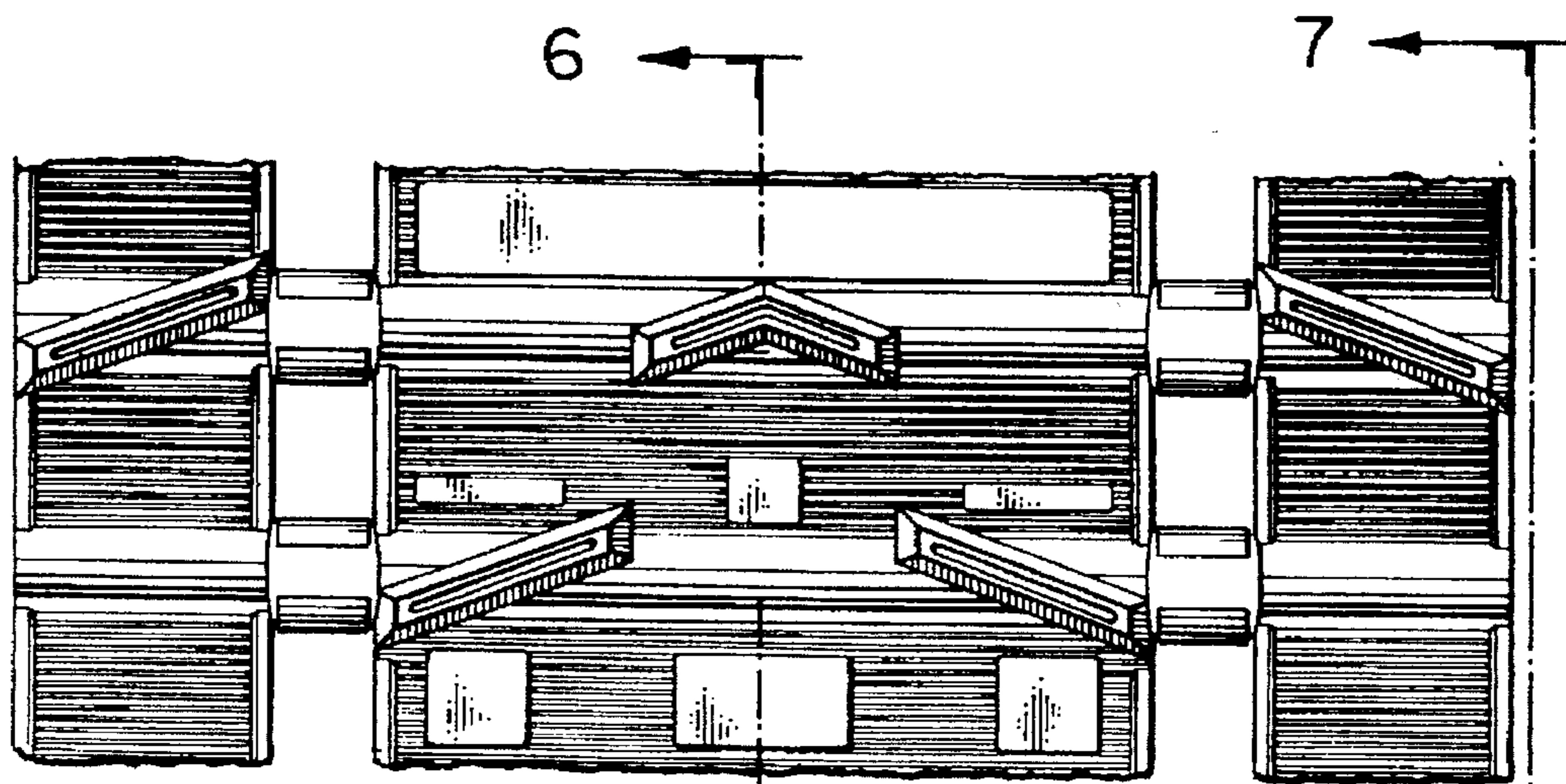

FIG. 5

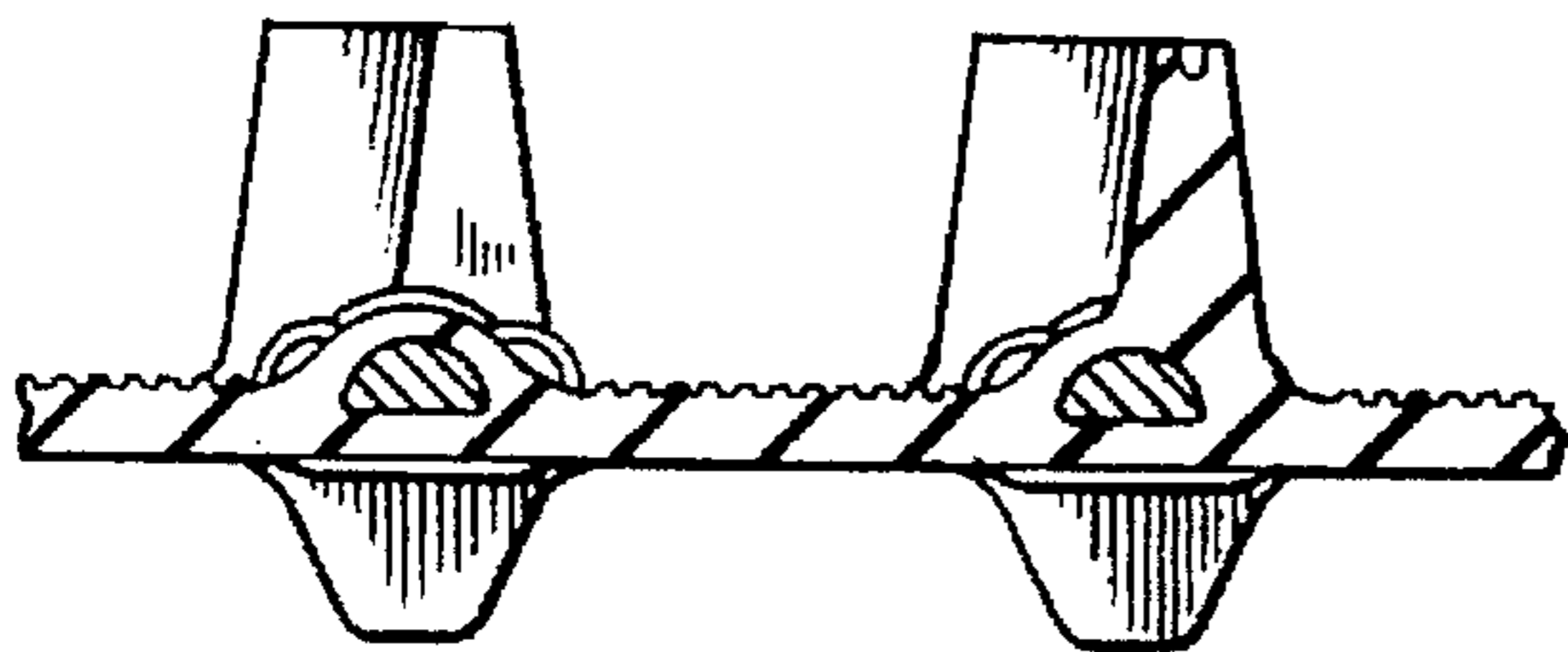

FIG. 6

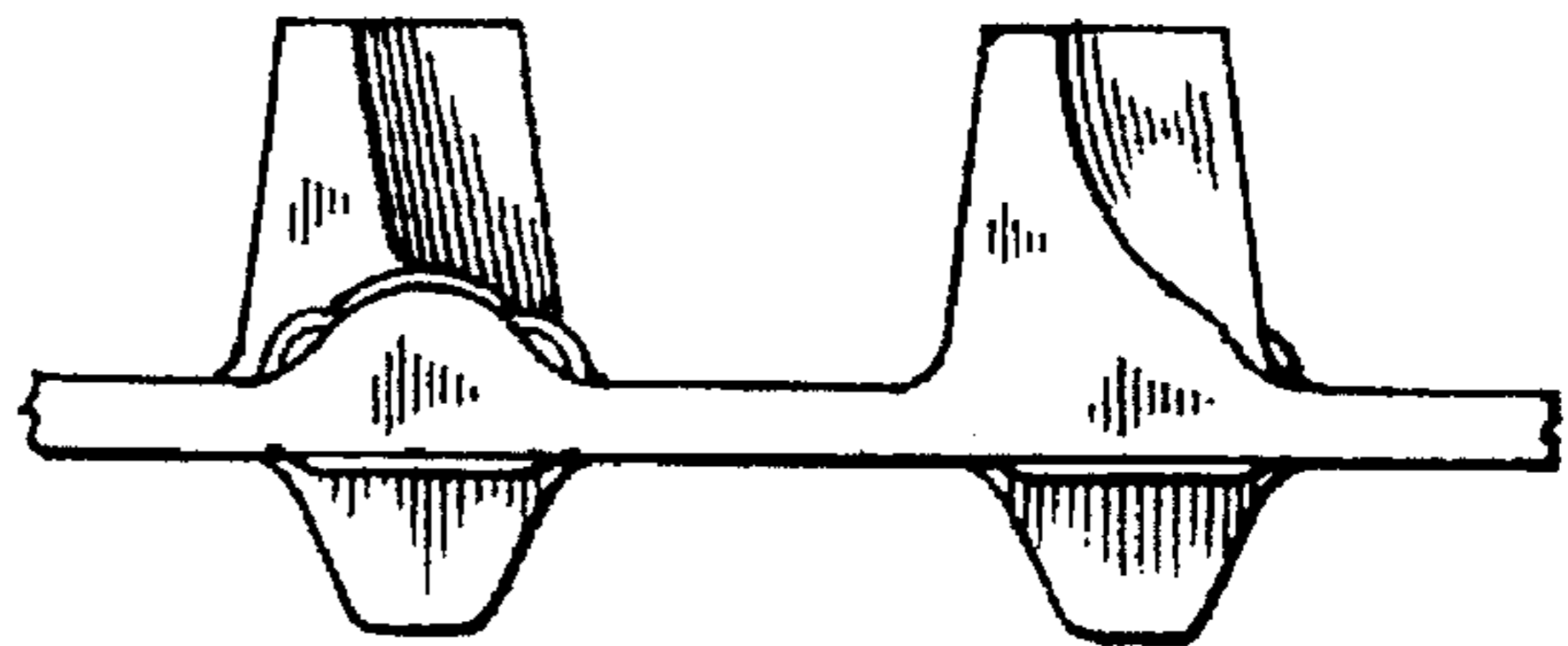

FIG. 7

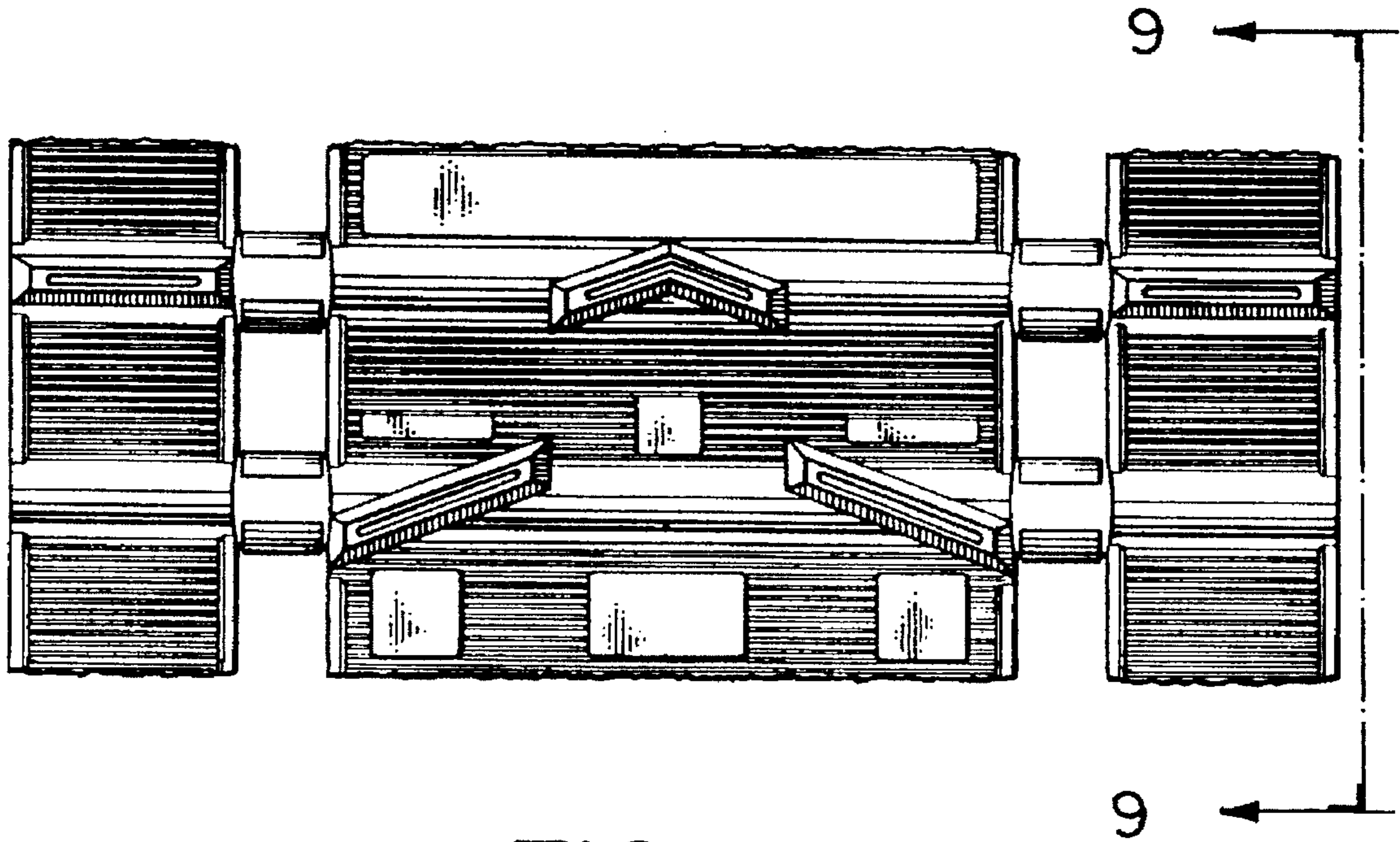

FIG. 8

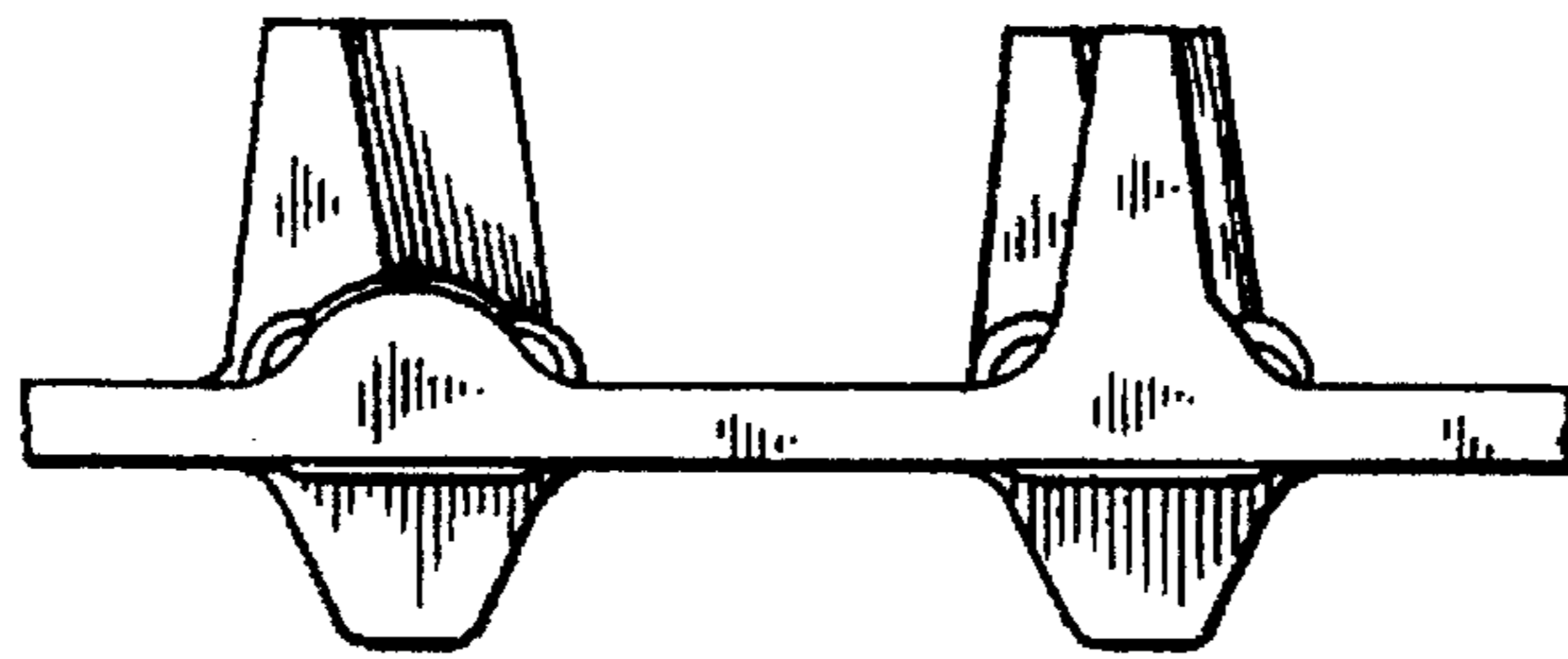

FIG. 9