



US00D380196S

**United States Patent** [19]  
**Aramaki**

[11] **Patent Number: Des. 380,196**  
[45] **Date of Patent: \*\*Jun. 24, 1997**

[54] **CONNECTOR**

[75] Inventor: **Keiji Aramaki**, Tokyo, Japan  
[73] Assignee: **Sony Corporation**, Tokyo, Japan  
[\*\*] Term: **14 Years**

[21] Appl. No.: **39,999**  
[22] Filed: **Jun. 8, 1995**

[30] **Foreign Application Priority Data**

Dec. 8, 1994 [JP] Japan ..... 6-37331  
Dec. 8, 1994 [JP] Japan ..... 6-37333

[51] **LOC (6) Cl.** ..... **13-03**  
[52] **U.S. Cl.** ..... **D13/147**  
[58] **Field of Search** ..... D13/146, 147;  
439/62, 76, 78, 82, 83, 607, 608, 609, 610

[56] **References Cited**

**U.S. PATENT DOCUMENTS**

D. 344,492 2/1994 Nakamura ..... D13/147  
D. 345,140 3/1994 Nakamura ..... D13/147  
5,017,156 5/1991 Sugiyama ..... 439/607  
5,073,130 12/1991 Nakamura ..... 439/607

*Primary Examiner*—Joel Sincavage  
*Attorney, Agent, or Firm*—Foley & Lardner

[57] **CLAIM**

The ornamental design for a connector, as shown and described.

**DESCRIPTION**

FIG. 1 is a perspective view of a first embodiment of the connector showing our new design;  
FIG. 2 is a top plan view thereof;  
FIG. 3 is a left side elevational view thereof;  
FIG. 4 is a front elevational view thereof;  
FIG. 5 is a right side elevational view thereof;  
FIG. 6 is a rear elevational view thereof;  
FIG. 7 is a bottom plan view thereof;  
FIG. 8 is a perspective view of a second embodiment of the connector showing our new design;  
FIG. 9 is a top plan view of the second embodiment shown in FIG. 8;  
FIG. 10 is a front elevational view of a second embodiment of the connector shown in FIG. 8;  
FIG. 11 is a rear elevational view of a second embodiment of the connector shown in FIG. 8; and,  
FIG. 12 is a bottom plan view of a second embodiment of the connector shown in FIG. 8.  
Left and right elevational views of the second embodiment are the same as those of the first embodiment shown in FIGS. 3 and 5.

**1 Claim, 4 Drawing Sheets**

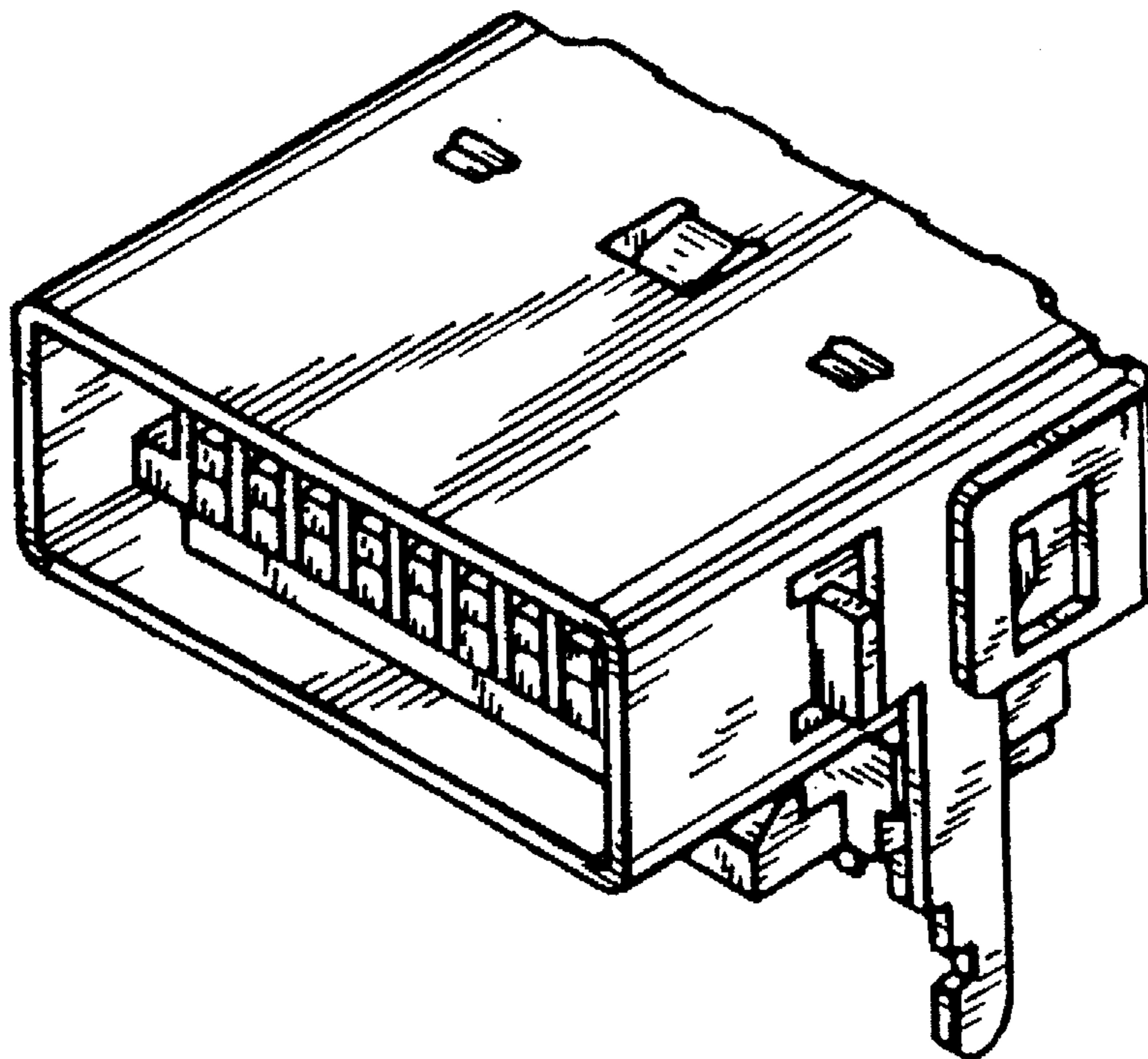

FIG. 1

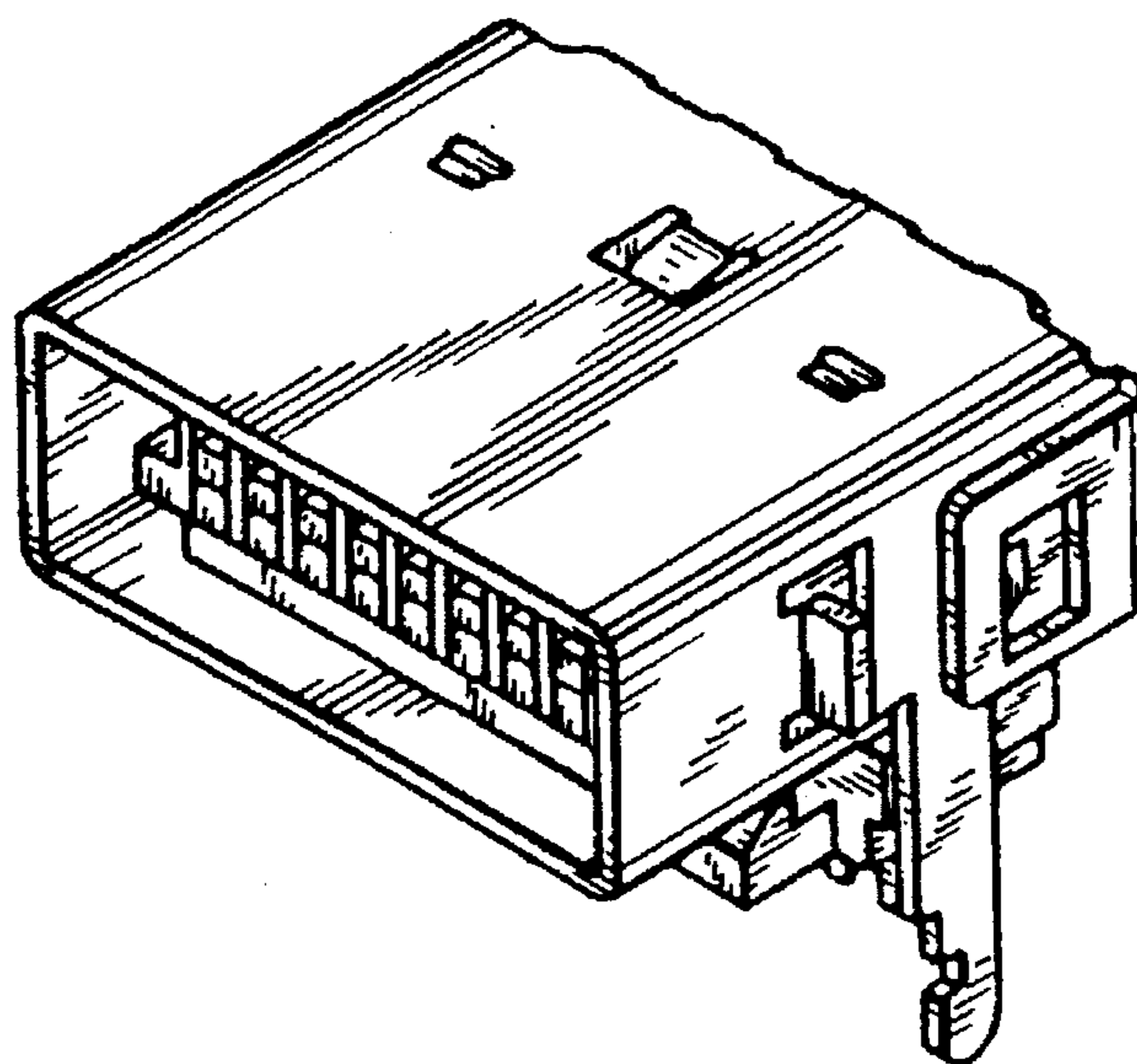

FIG. 2

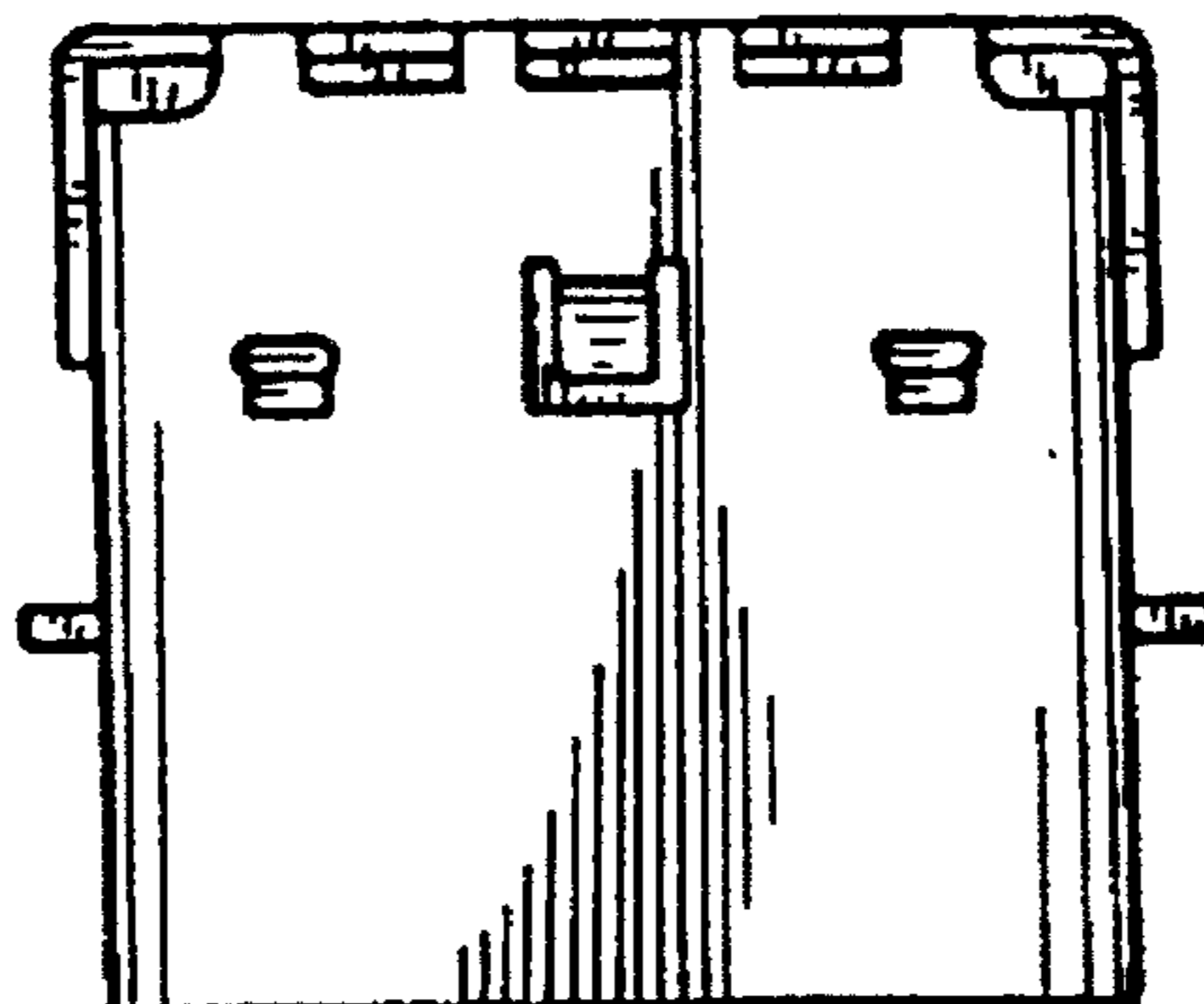

FIG. 3

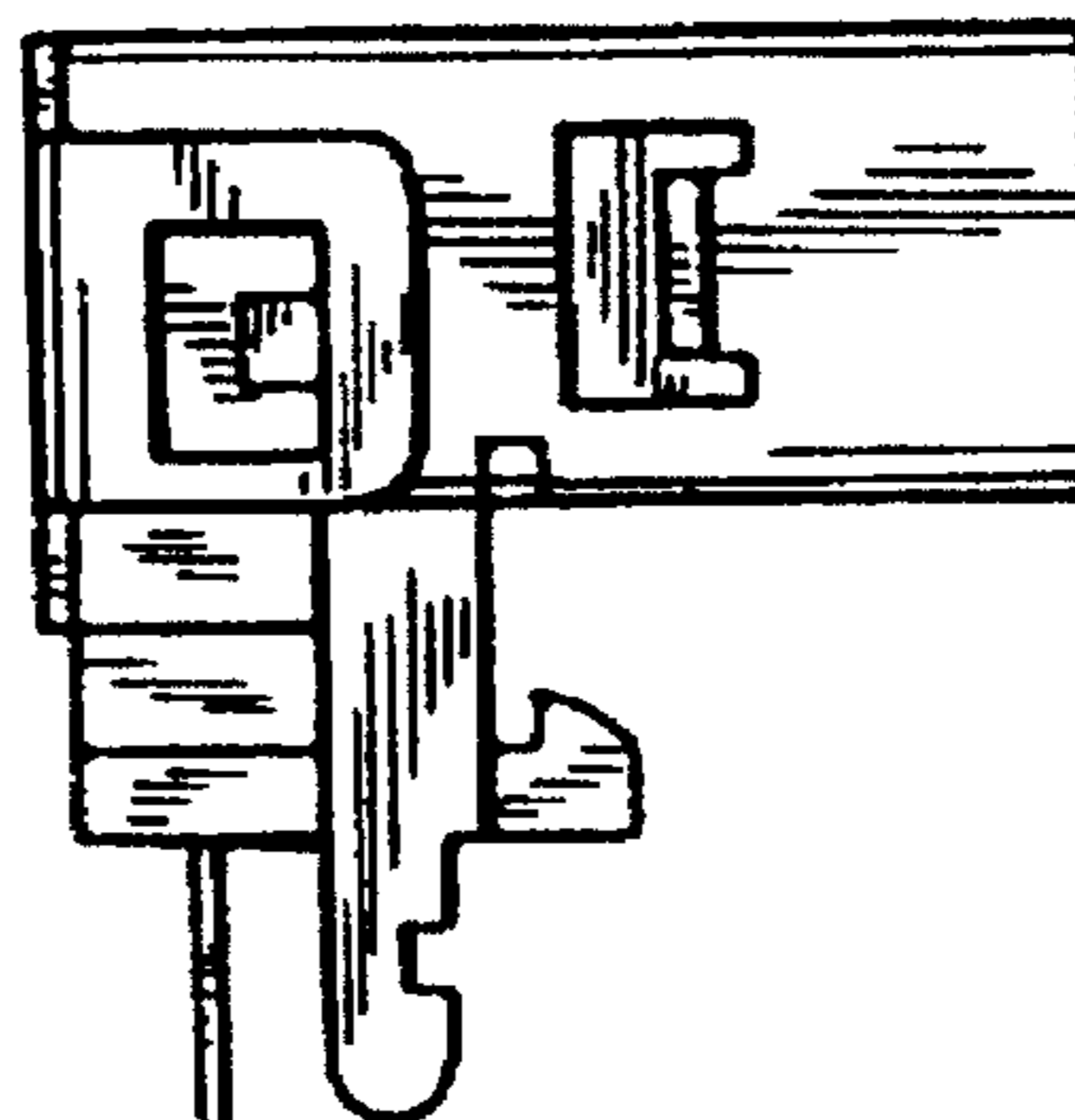

FIG. 4

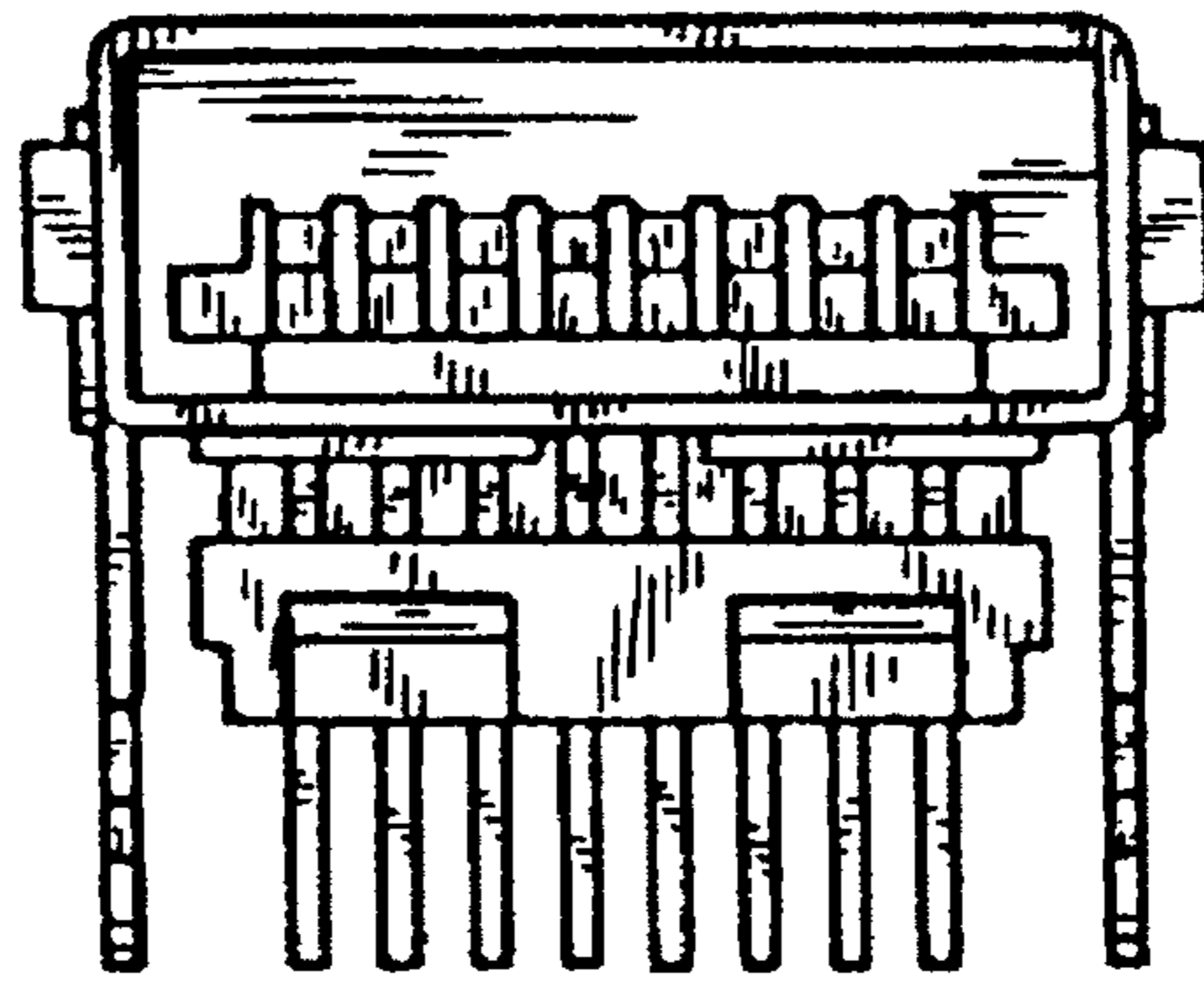

FIG. 5

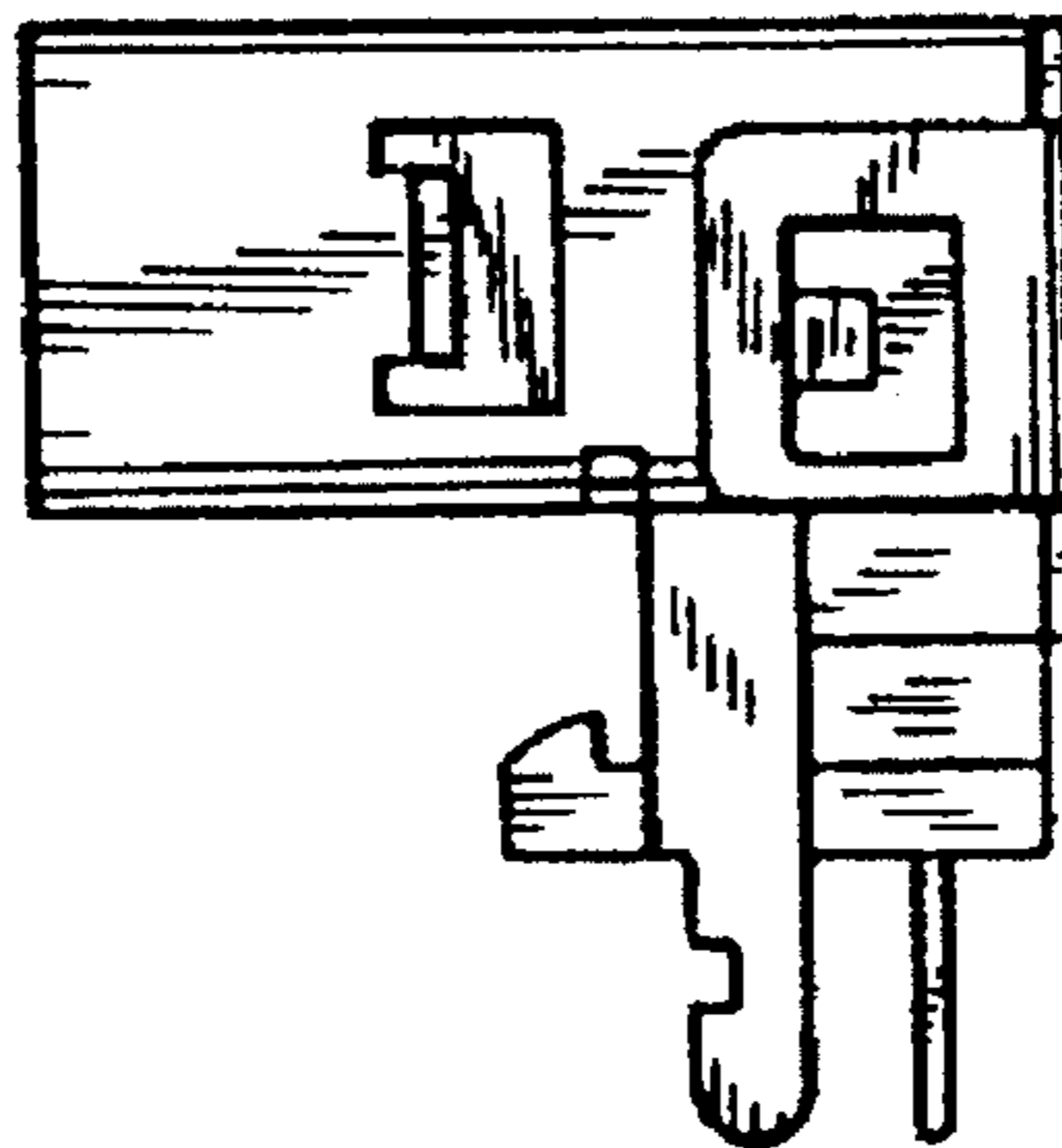

FIG. 6

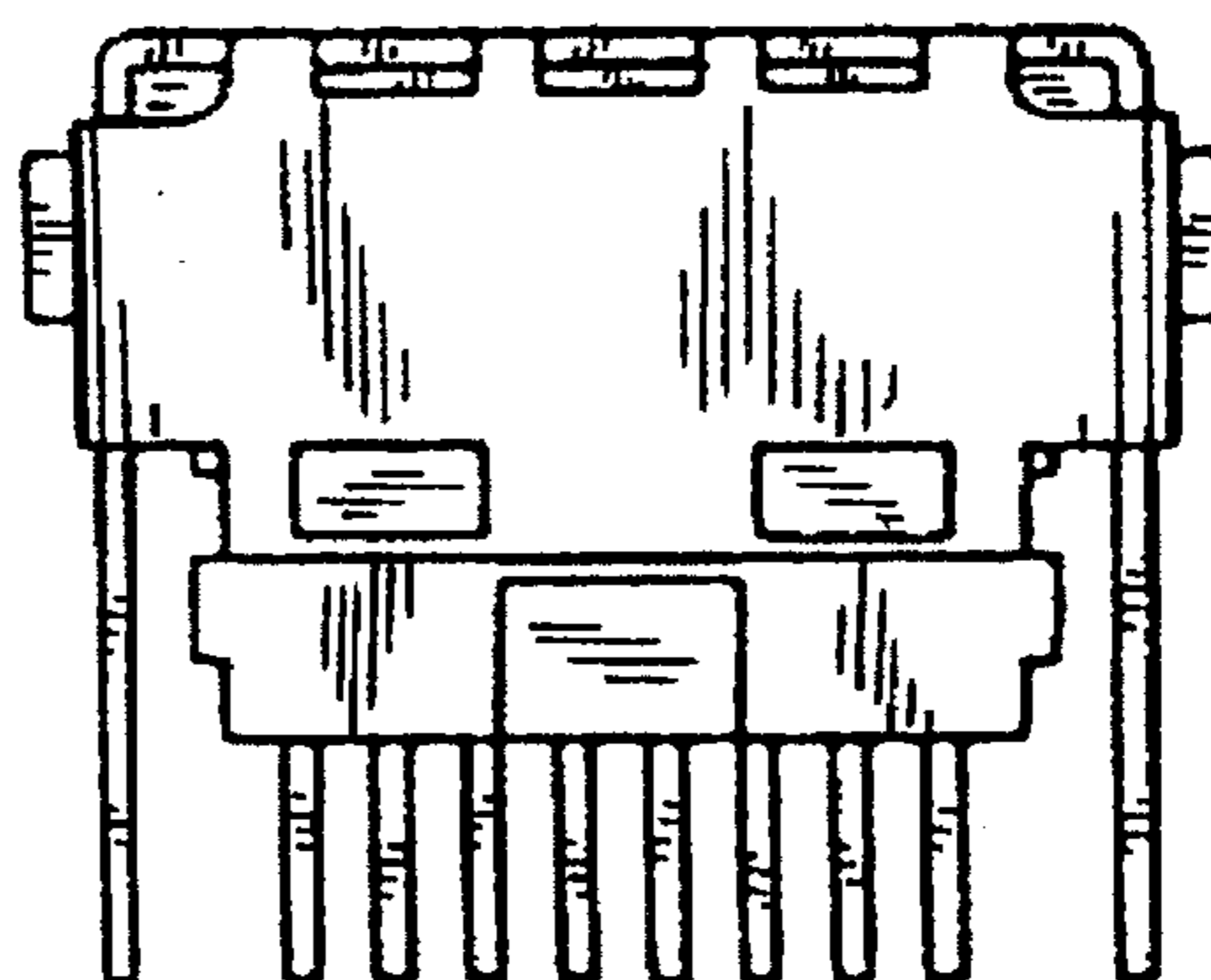

FIG. 7

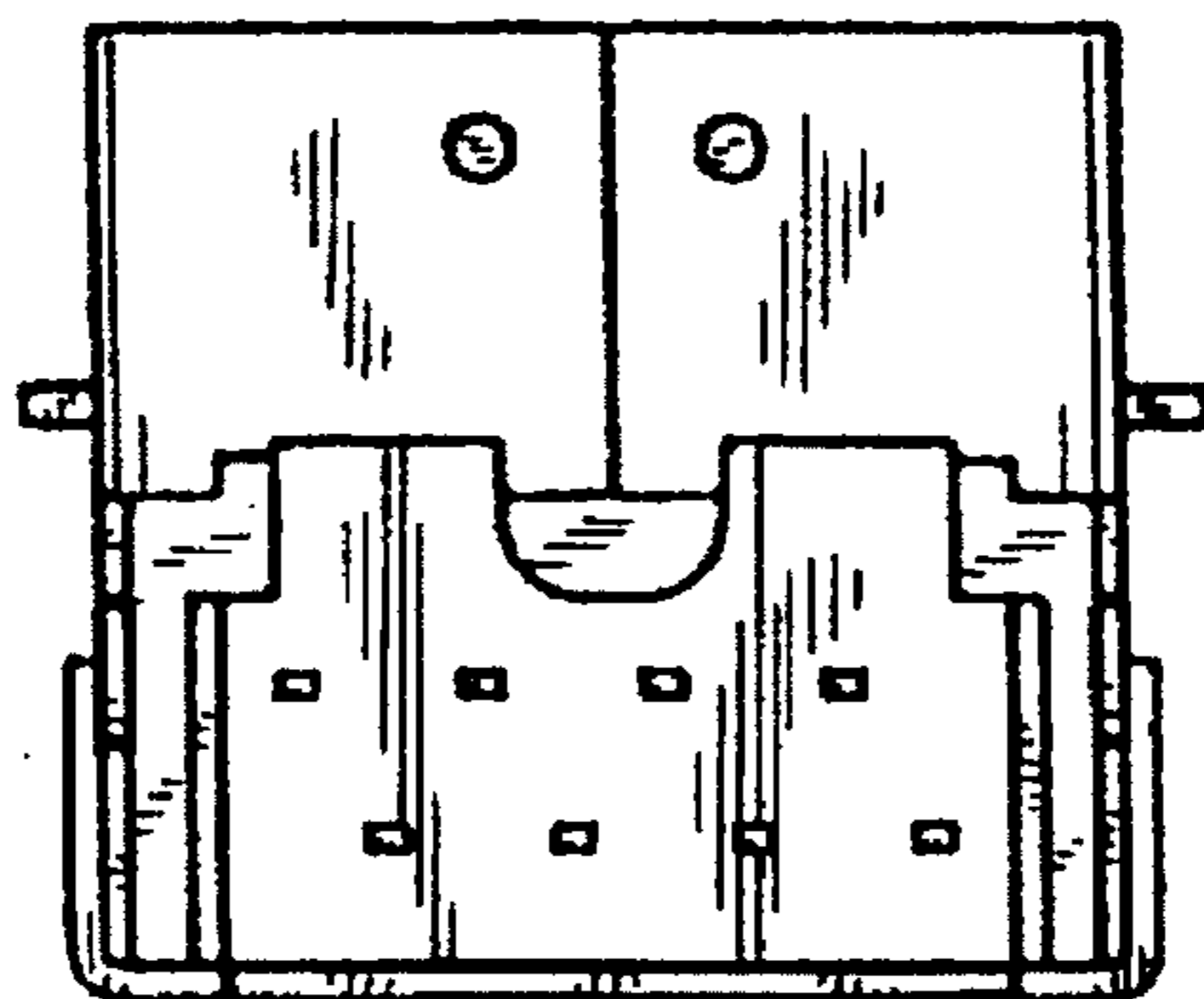

FIG. 8

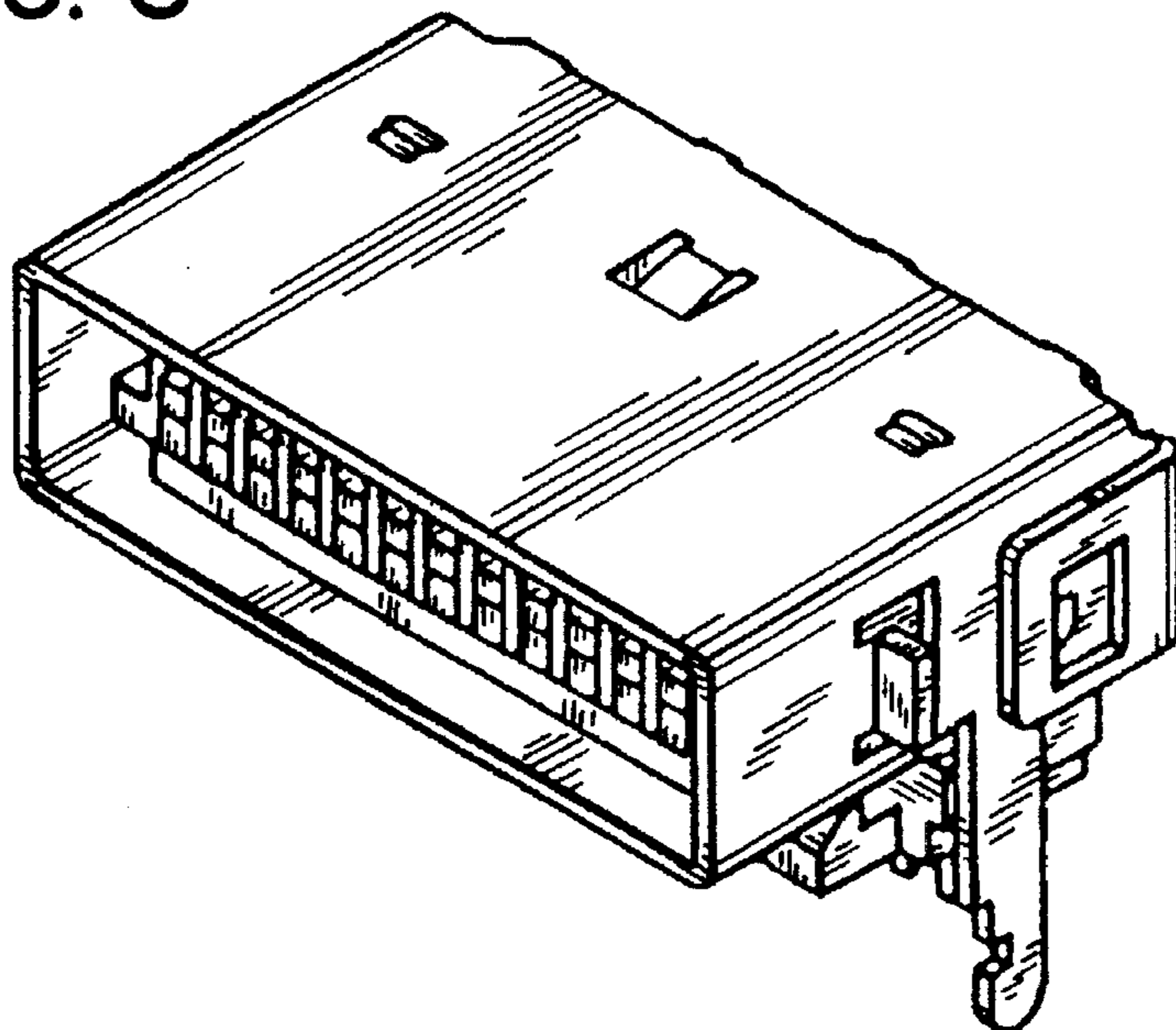

FIG. 9

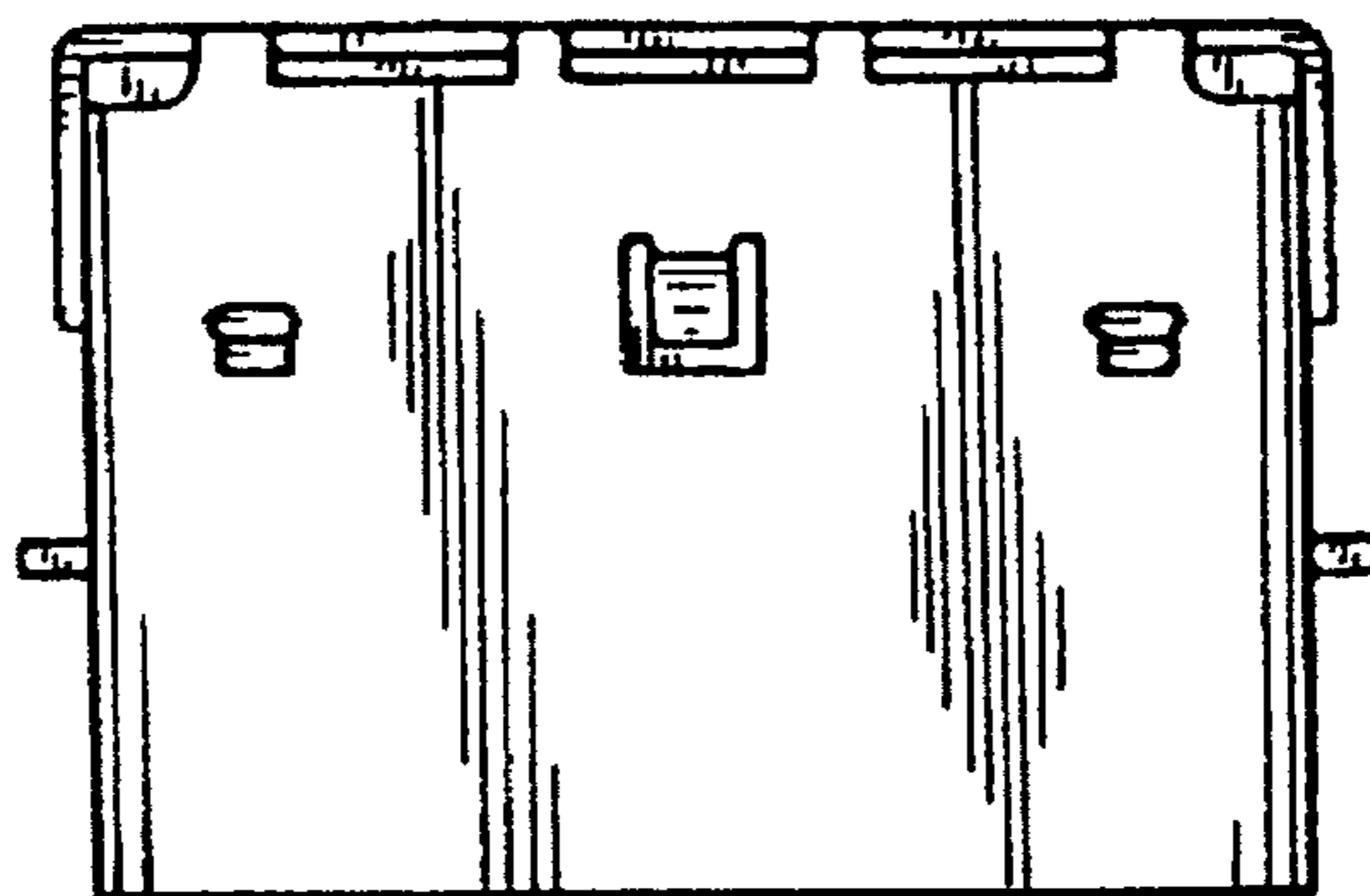

FIG. 10

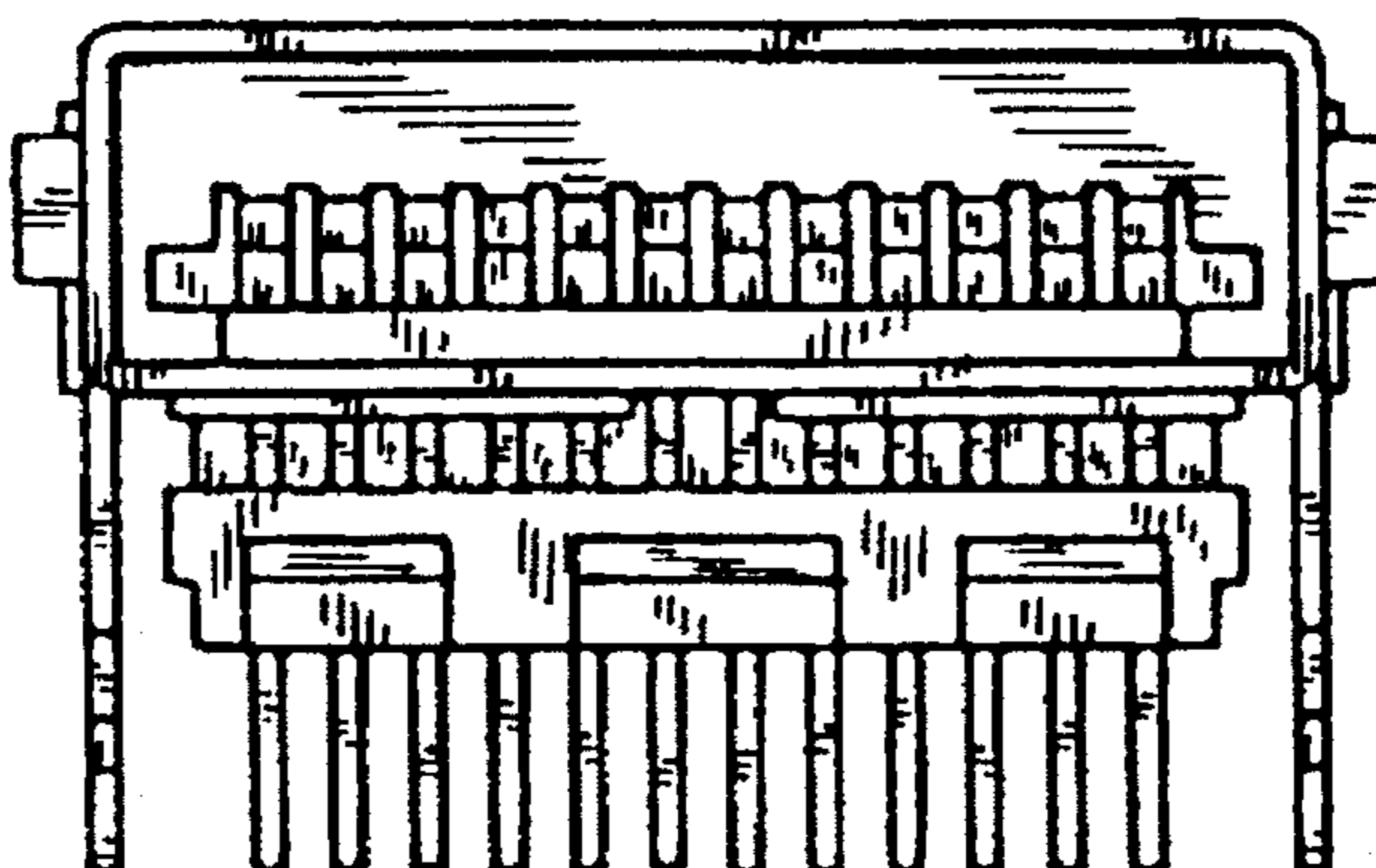

FIG. 11

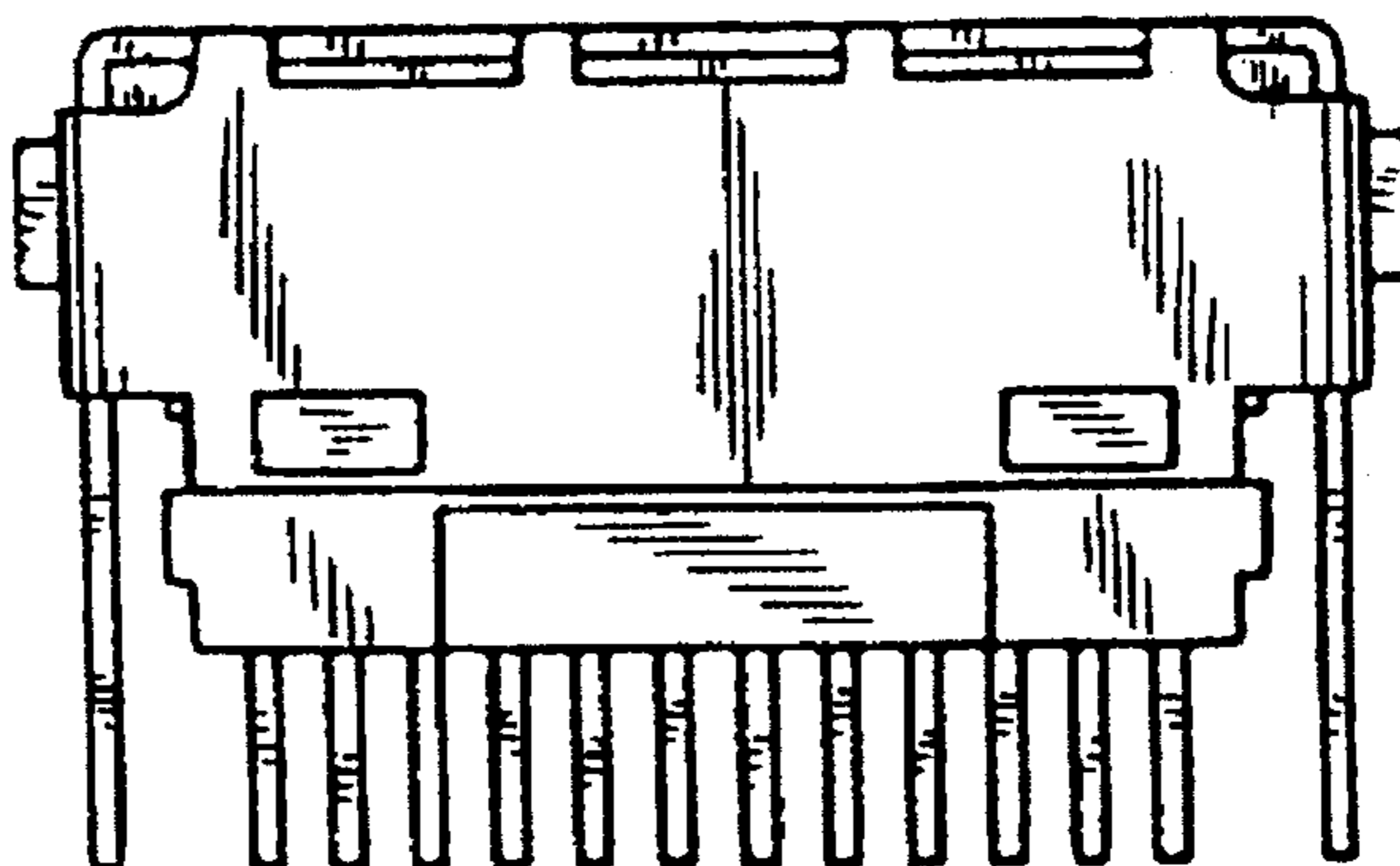

FIG. 12

