



US00D380190S

United States Patent [19] Slayter

[11] Patent Number: Des. 380,190
[45] Date of Patent: **Jun. 24, 1997

[54] PASSENGER SLIDING TRAY

[75] Inventor: John D. Slayter, Elkhart, Ind.
[73] Assignee: Holiday Rambler LLC, Wakarusa, Ind.
[**] Term: 14 Years

[21] Appl. No.: 33,891
[22] Filed: Jan. 23, 1995

[51] LOC (6) Cl. 12-16
[52] U.S. Cl. D12/425
[58] Field of Search D12/425, 192;
D6/406, 429, 511, 627; 108/43-45, 47

[56] References Cited

U.S. PATENT DOCUMENTS

D. 272,402	1/1984	Marrujo	D6/511	X
D. 285,632	9/1986	Axhamre	D6/429	X
D. 287,678	1/1987	Hatcher et al.	D6/429	X
D. 298,493	11/1988	Hatcher et al.	D6/429	X
D. 328,680	8/1992	Zapf	D6/511	
2,792,267	5/1957	Hubbard	311/21	
3,279,872	10/1966	Howke	312/235	
3,345,118	10/1967	Cummings	312/235	
3,589,577	6/1971	Basinger	224/42	
4,417,764	11/1983	Marcus et al.	108/44	X
4,792,174	12/1988	Shioda	108/45	X
5,092,507	3/1992	Szablak et al.	224/275	
5,140,914	8/1992	Bohbot et al.	108/44	
5,143,337	9/1992	Tomayko, Jr. et al.	108/44	X
5,177,665	1/1993	Frank et al.	361/380	

FOREIGN PATENT DOCUMENTS

1218314	5/1960	France	108/45
1335906	7/1963	France	108/45
3-50036	3/1991	Japan	108/45

Primary Examiner—B. J. Bullock
Assistant Examiner—Cathron B. Matta
Attorney, Agent, or Firm—Leydig, Voit & Mayer, Ltd.

[57] CLAIM

The ornamental design for a passenger sliding tray, as shown and described.

DESCRIPTION

FIG. 1 is an upper right hand perspective view of the passenger sliding tray shown in its closed position; FIG. 2 is an upper right hand perspective view of the passenger sliding tray shown in its open position; FIG. 3 is a front end view of the passenger sliding tray; FIG. 4 is a bottom view of the passenger sliding tray in its open position; FIG. 5 is a top plan view of the passenger sliding tray in its closed position; and, FIG. 6 is a side elevational view of the passenger sliding tray in its open position, the other side view being a mirror image thereof.

The broken line showing of a vehicle dashboard in all of the views is for illustrative purposes only and forms no part of the claimed design.

1 Claim, 2 Drawing Sheets

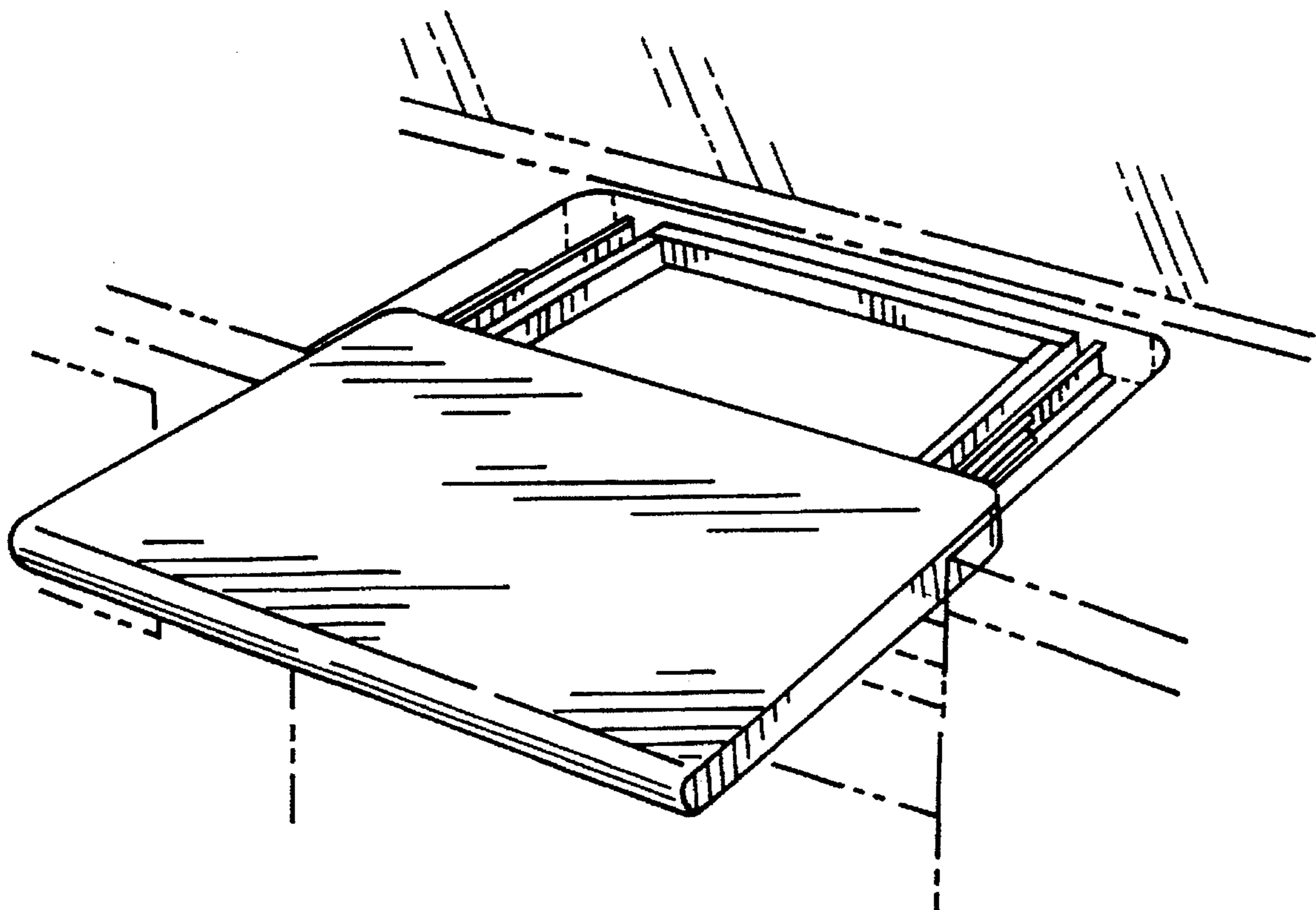

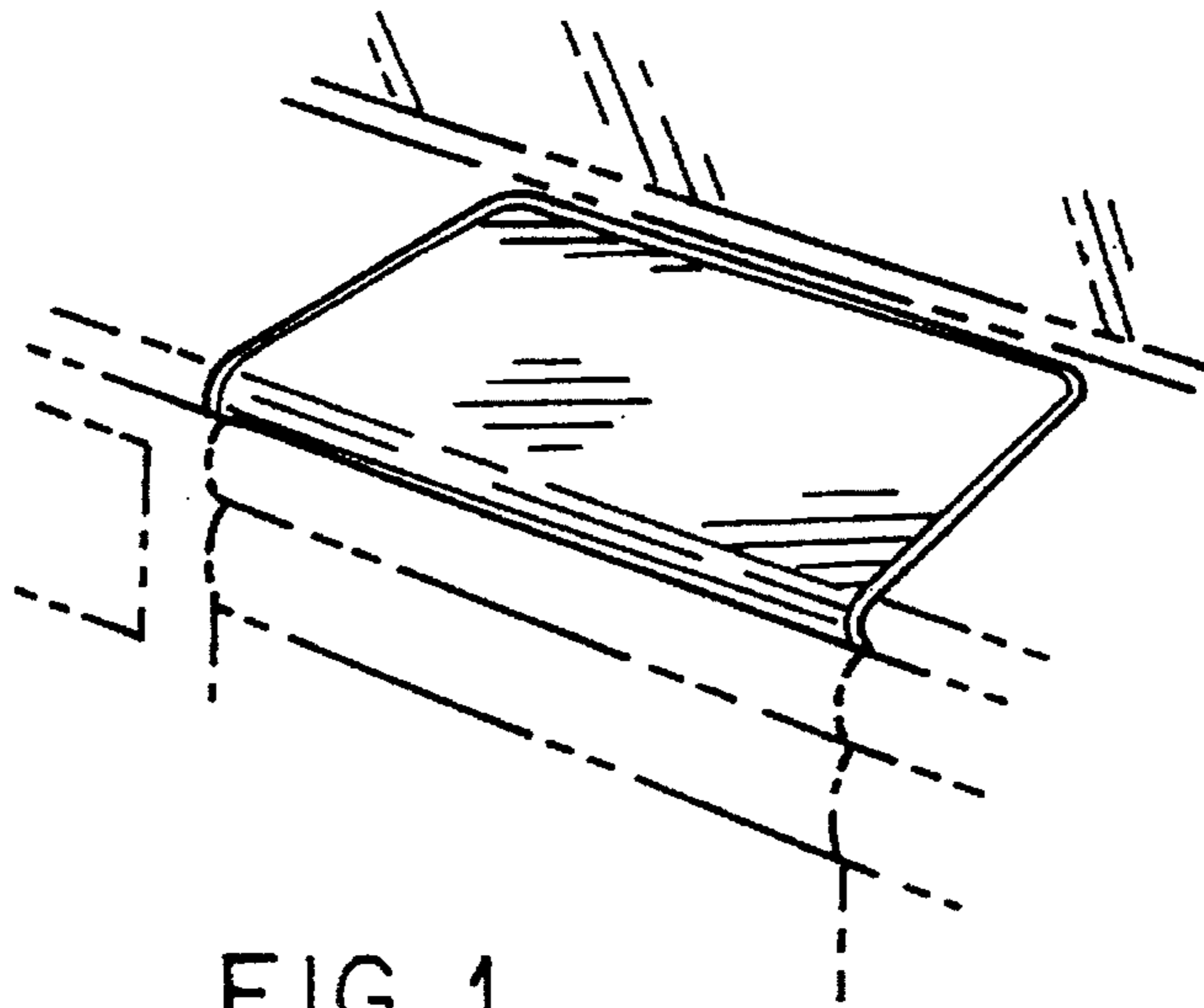

FIG. 1

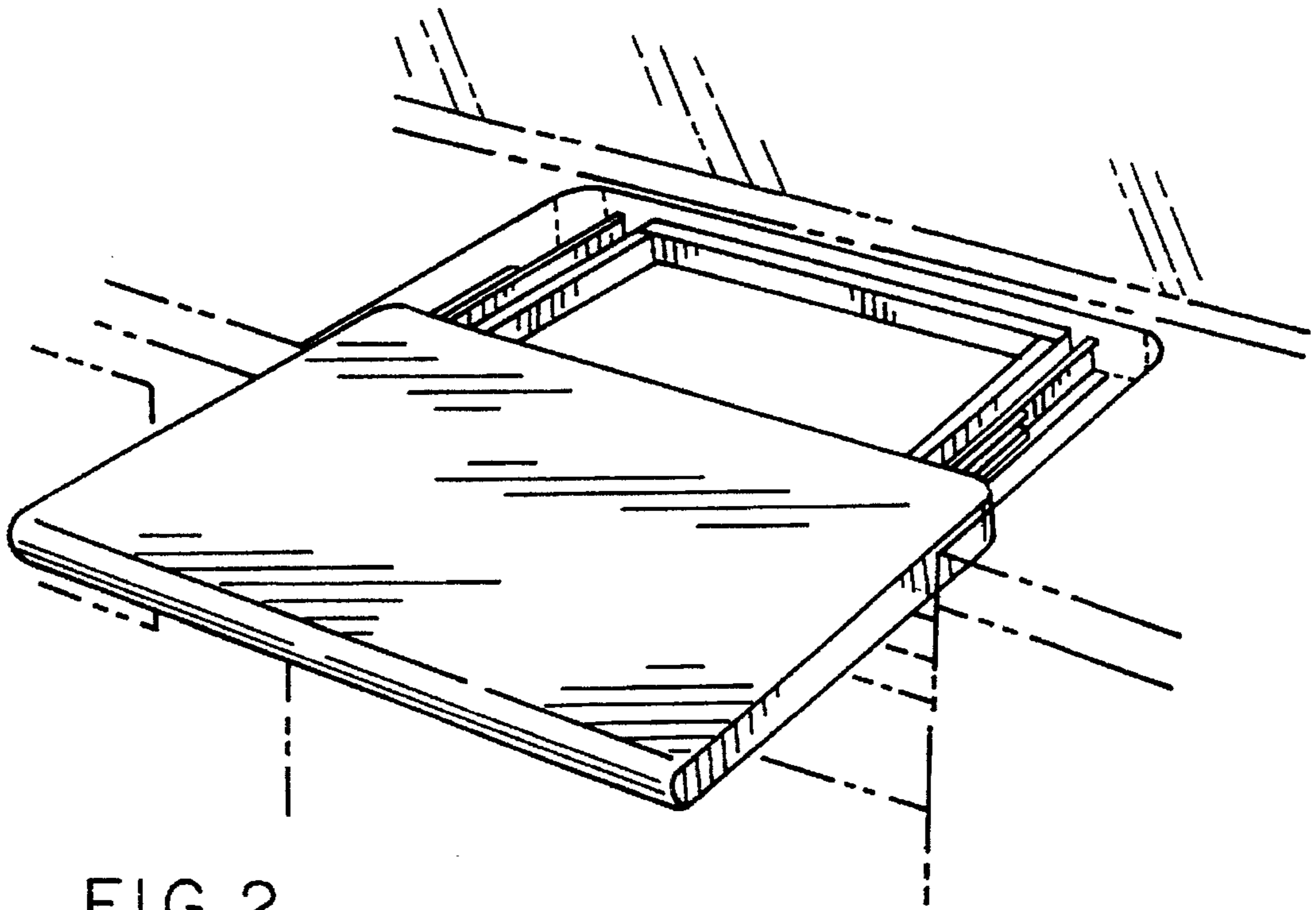

FIG. 2

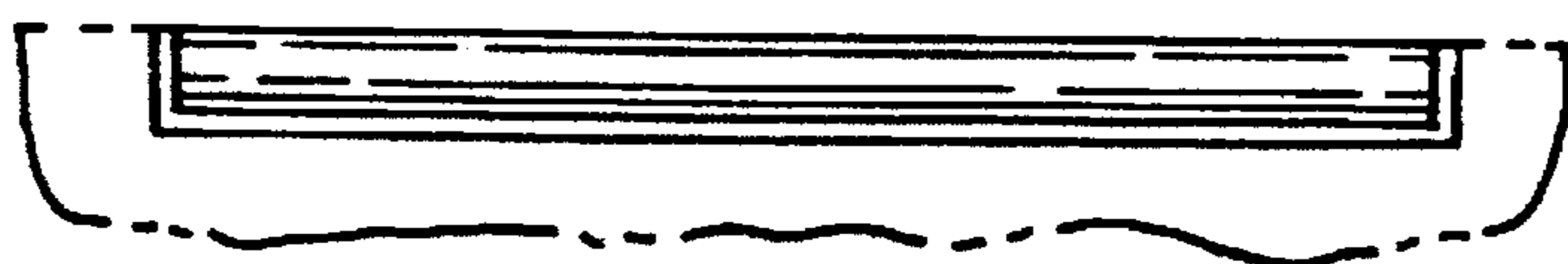

FIG. 3

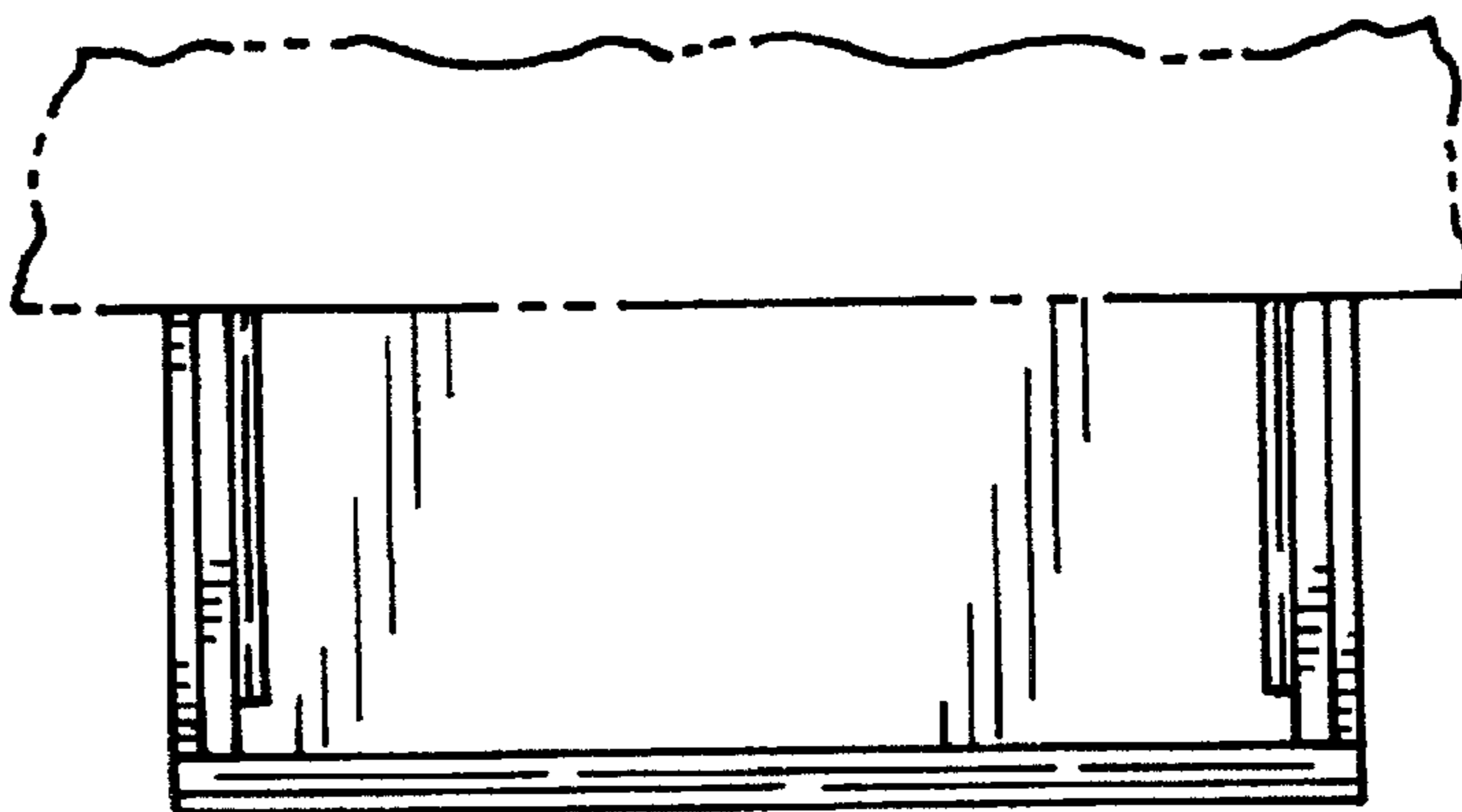

FIG. 4

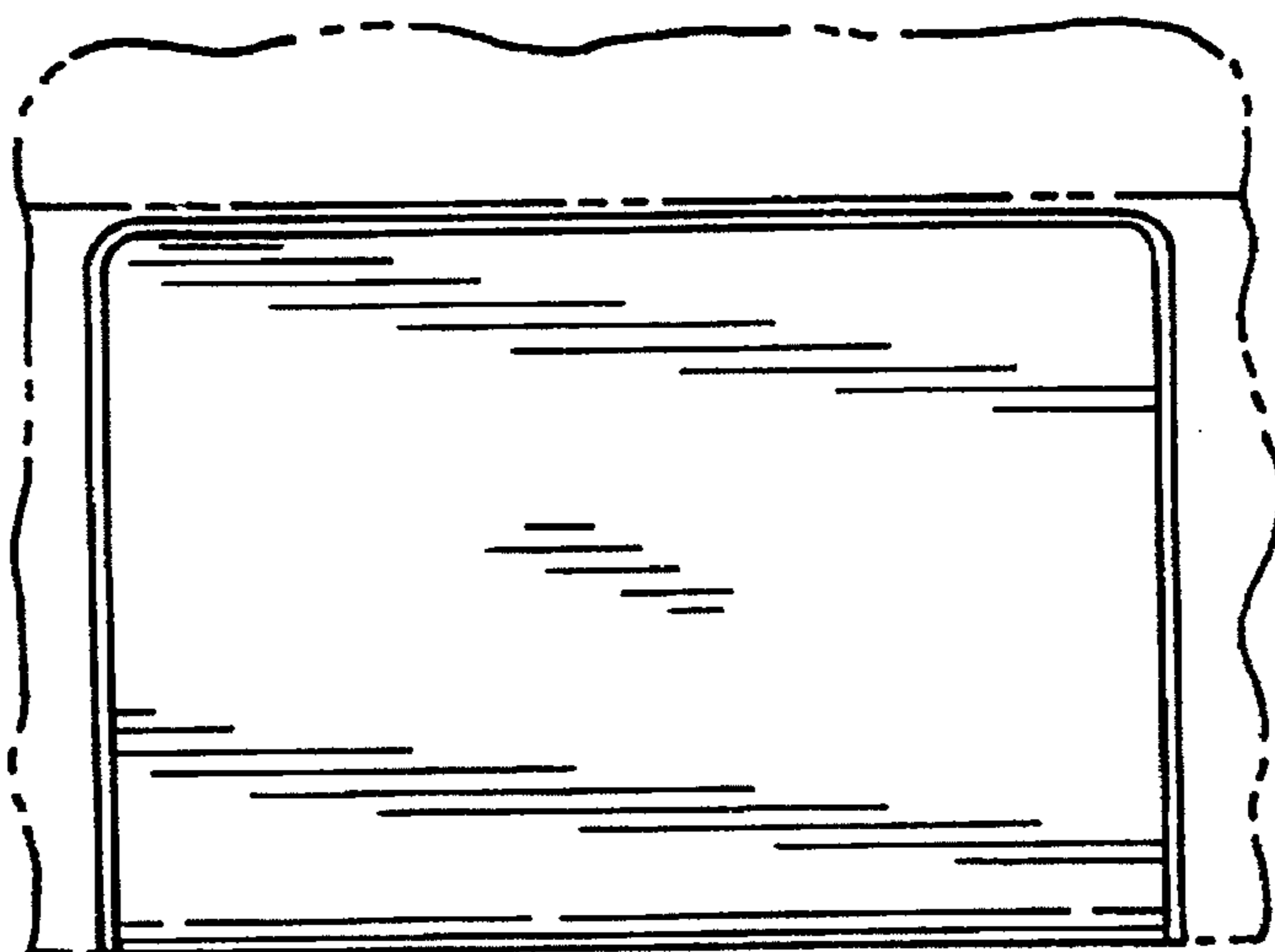

FIG. 5

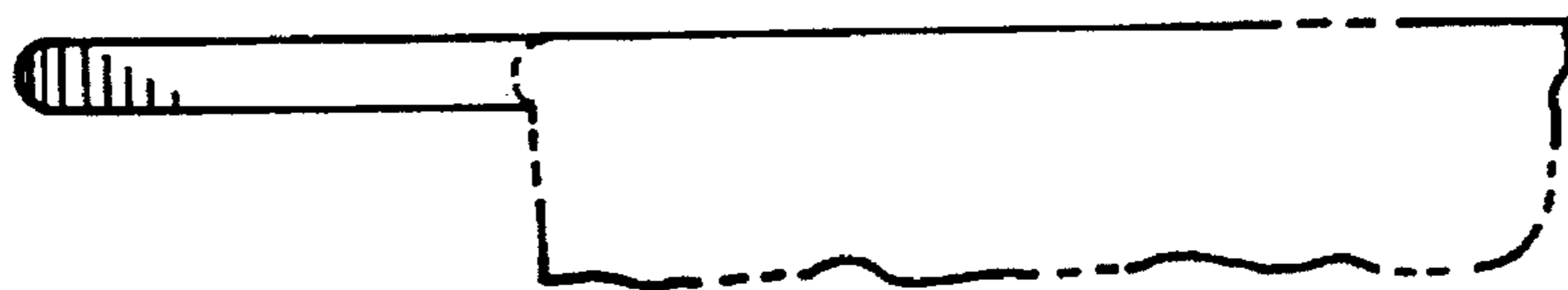

FIG. 6