



US00D380187S

# United States Patent [19]

[11] Patent Number: **Des. 380,187**

**Brown**

[45] Date of Patent: **\*\*Jun. 24, 1997**

[54] **CROSS BEAMS FOR INTERCONNECTING BOAT HULLS**

4,998,498 3/1991 Gallichan ..... 114/61

[76] Inventor: **James W. Brown**, P.O. Box 550, North, Va. 23128

*Primary Examiner*—Kay H. Chin  
*Attorney, Agent, or Firm*—Nixon & Vanderhye

[\*\*] Term: **14 Years**

[57] **CLAIM**

[21] Appl. No.: **48,715**

The ornamental design for cross beams for interconnecting boat hulls, as shown and described.

[22] Filed: **Jan. 11, 1996**

**DESCRIPTION**

[51] LOC (6) Cl. .... **12-06**

[52] U.S. Cl. .... **D12/317; D12/304**

[58] Field of Search ..... D12/300, 303, D12/304, 317, 318; 114/61, 39.1, 345

FIG. 1 is a top and side perspective view of cross beams for interconnecting boat hulls, the hulls being illustrated by the dot-dash lines showing the environment for the cross beams but not forming part of the present design;

FIG. 2 is a top plan view of the cross beams hereof;

FIG. 3 is a left side elevational view thereof, the right side view being a mirror image thereof;

FIG. 4 is a front elevational view thereof;

FIG. 5 is a rear elevational view thereof; and,

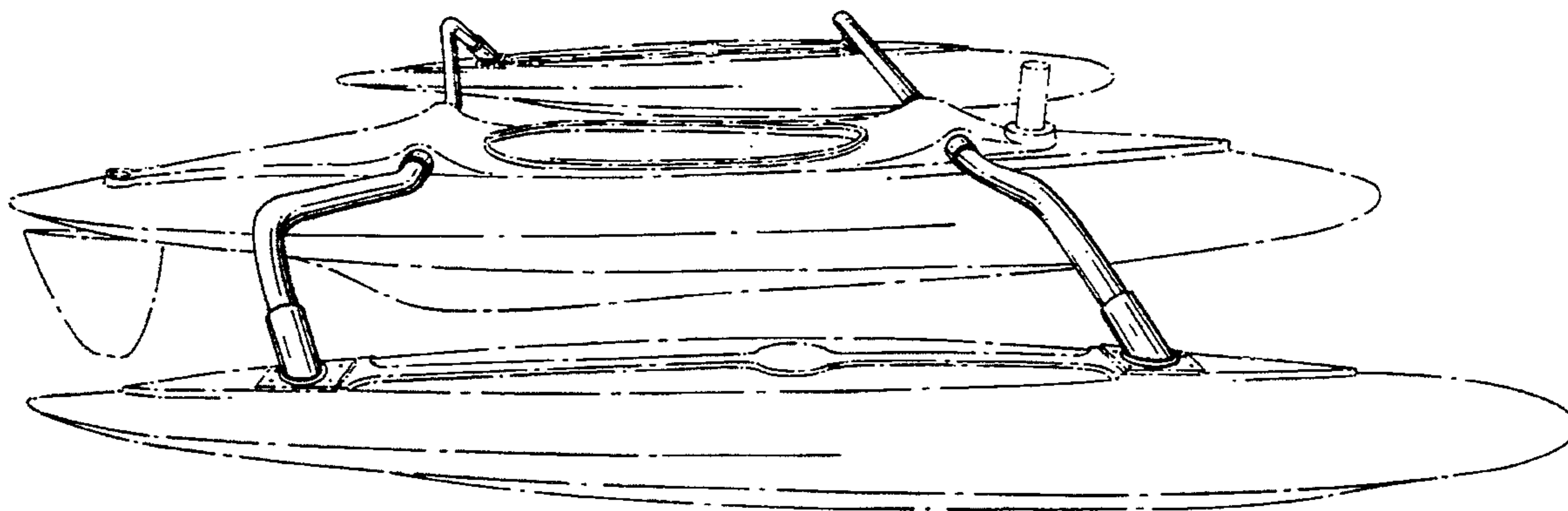
FIG. 6 is a bottom plan view thereof.

[56] **References Cited**

**U.S. PATENT DOCUMENTS**

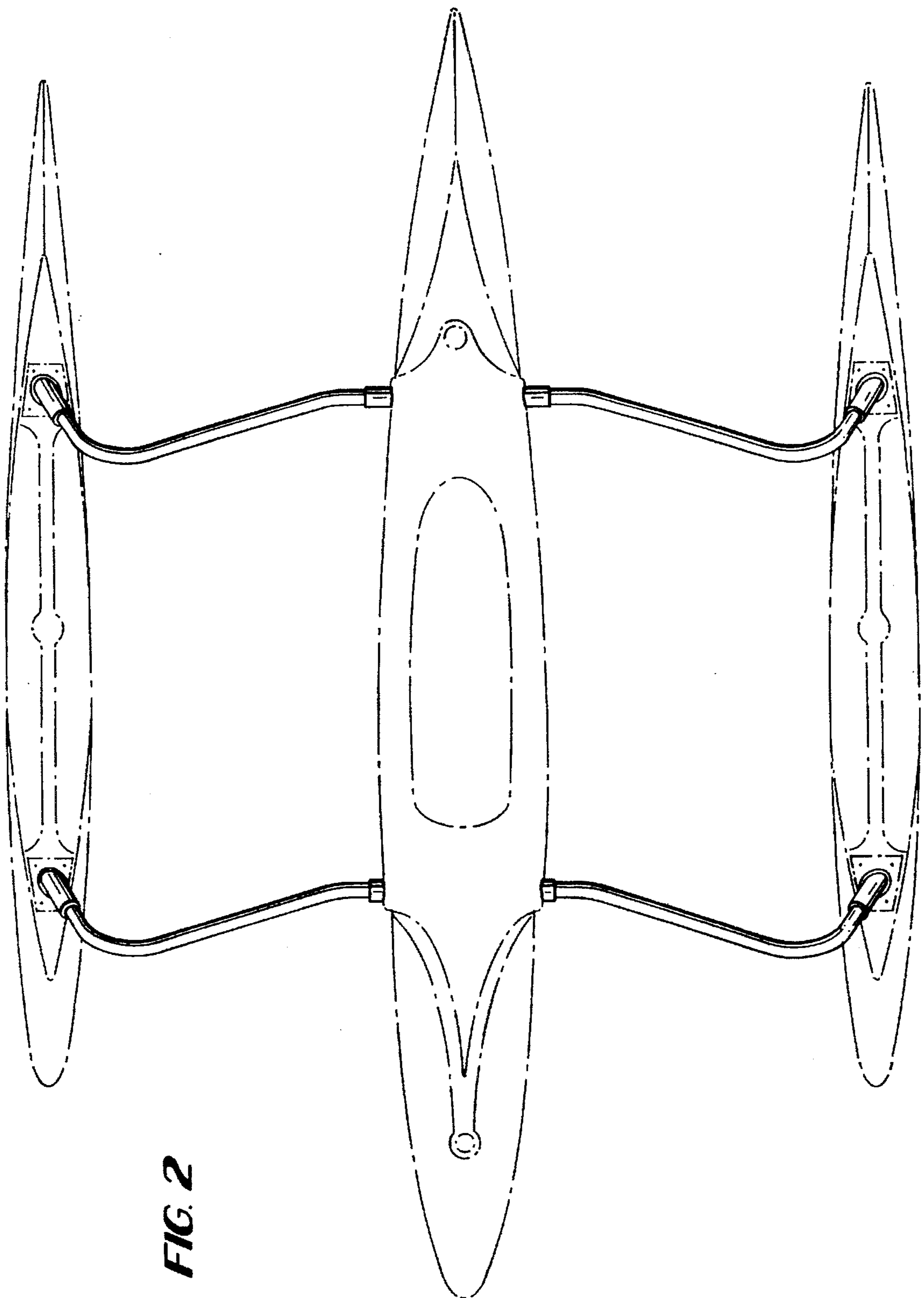
- D. 256,572 8/1980 Jedzinski ..... D12/310
- D. 335,860 5/1993 Trotter ..... D12/303
- 4,136,414 1/1979 Popkin ..... 114/61

**1 Claim, 5 Drawing Sheets**



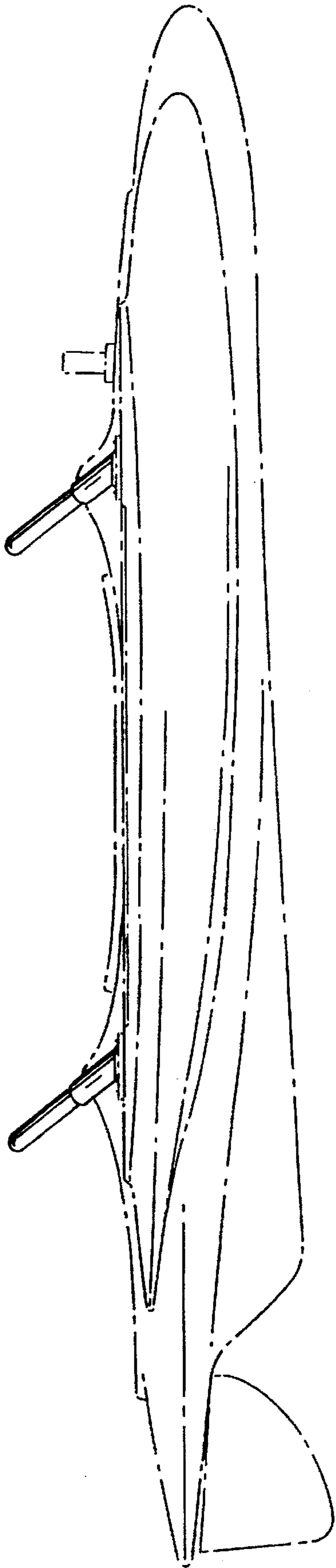


**FIG. 1**

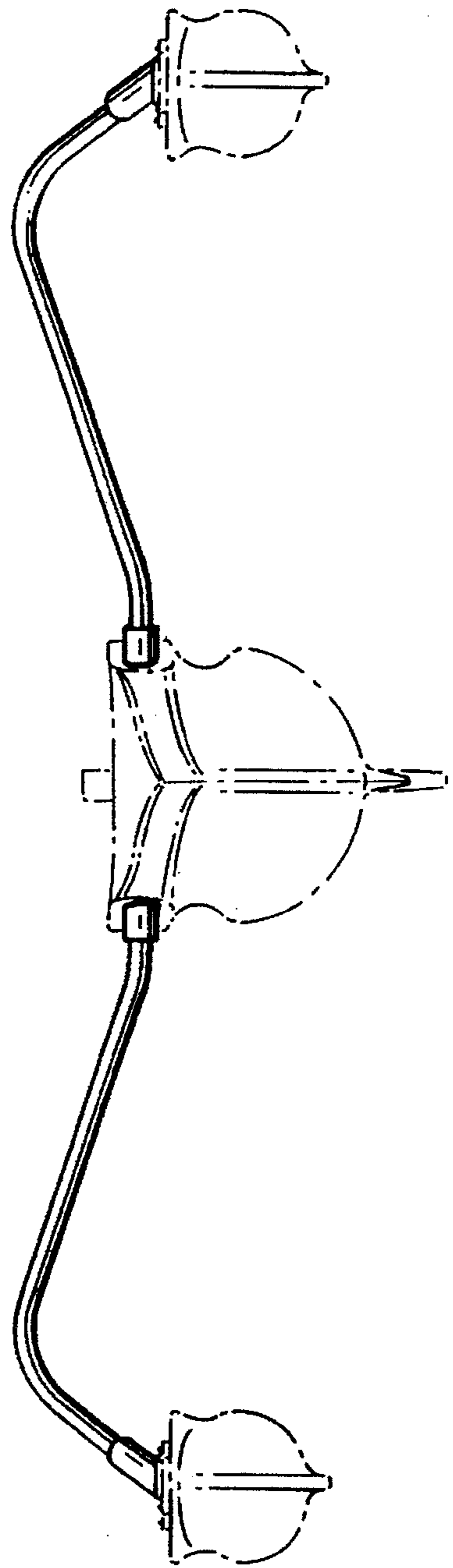


**FIG. 2**

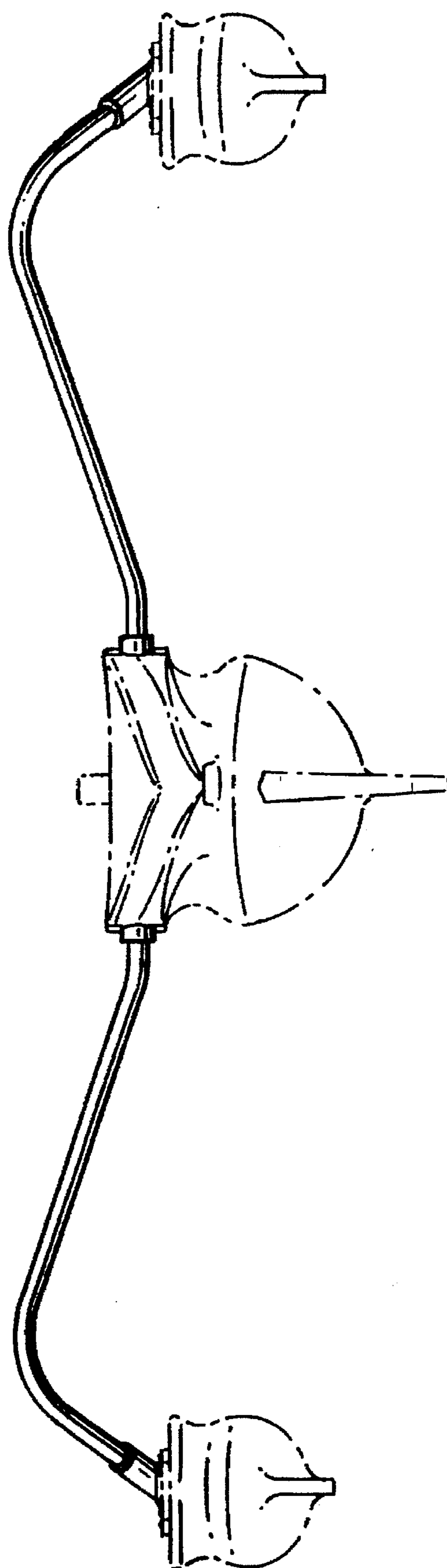
**FIG. 3**

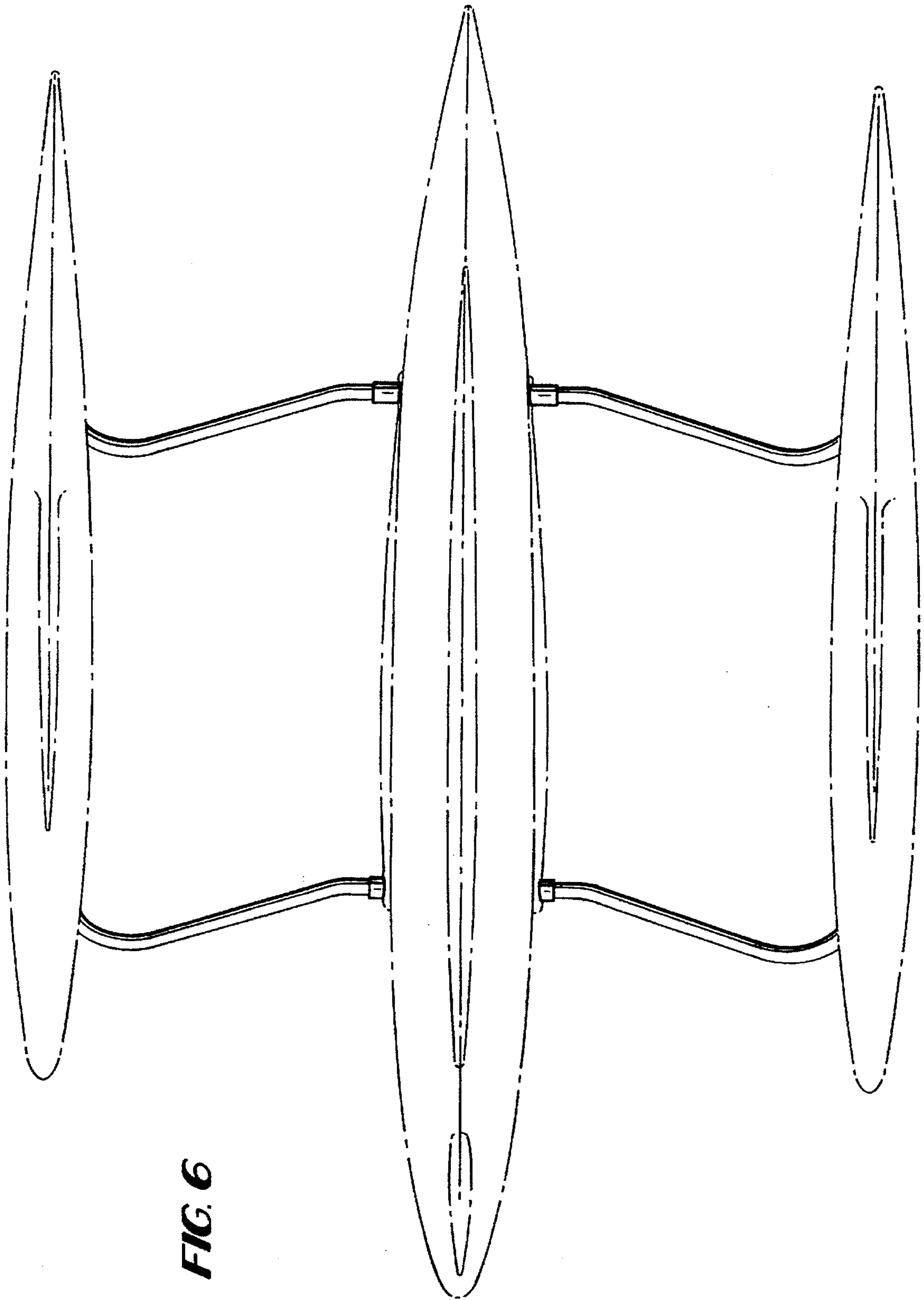


**FIG. 4**



**FIG. 5**





**FIG. 6**