



US00D379966S

# United States Patent [19] Gallagher

[11] Patent Number: Des. 379,966

[45] Date of Patent: \*\*Jun. 17, 1997

[54] TELEPHONE OPERATED APPLIANCE  
CONTROLLER

4,373,120	2/1983	McDonald	379/442 X
4,861,286	8/1989	Fosnaugh	439/651
5,099,514	3/1992	Acree	379/441

[76] Inventor: Colin Gallagher, 17 Prospect Ave.,  
Glasnevin, Dublin 9, Eire, Ireland

### OTHER PUBLICATIONS

[\*\*] Term: 14 Years

Aero-Tech Light Bulb Co., Advantage-II At Center Of  
Page.

[21] Appl. No.: 53,366

Panamax Surge Suppressor Advertisement. Model SS120/1.  
HELLO Direct Spring 1994, p. 1960, Power2Go Item At  
Bottom Right.

[22] Filed: Apr. 19, 1996

Primary Examiner—Jeffrey Asch

[51] LOC (6) Cl. .... 13-03

Attorney, Agent, or Firm—Harold H. Dutton, Jr.; W. Charles  
L. Jamison; Diane F. Liebman

[52] U.S. Cl. .... D13/142; D14/240

[58] Field of Search ..... D13/142, 158,  
D13/110, 184, 160; D14/140, 240, 256,  
107, 114; 379/332, 419, 420, 428, 440,  
441, 442

### [57] CLAIM

The ornamental design for a telephone operated appliance  
controller, as shown.

### [56] References Cited

### DESCRIPTION

#### U.S. PATENT DOCUMENTS

D. 263,465	3/1982	Fathi	D13/110
D. 278,463	4/1985	Vest	D13/110 X
D. 317,311	6/1991	Anderson et al.	D14/240
D. 338,873	8/1993	Sue	D13/142 X
D. 340,246	10/1993	Newman	D14/240
D. 340,457	10/1993	Lennon, III	D14/240
D. 351,600	10/1994	Mosccone	D14/240
D. 367,262	2/1996	Lux	D13/142
2,988,617	6/1961	Graziosi	439/651 X

FIG. 1 is a perspective view of a telephone operated appli-  
ance controller showing my new design;  
FIG. 2 is a front view thereof;  
FIG. 3 is a rear view thereof;  
FIG. 4 is a right view thereof;  
FIG. 5 is a left view thereof;  
FIG. 6 is a top view thereof; and,  
FIG. 7 is a bottom view thereof.

1 Claim, 5 Drawing Sheets

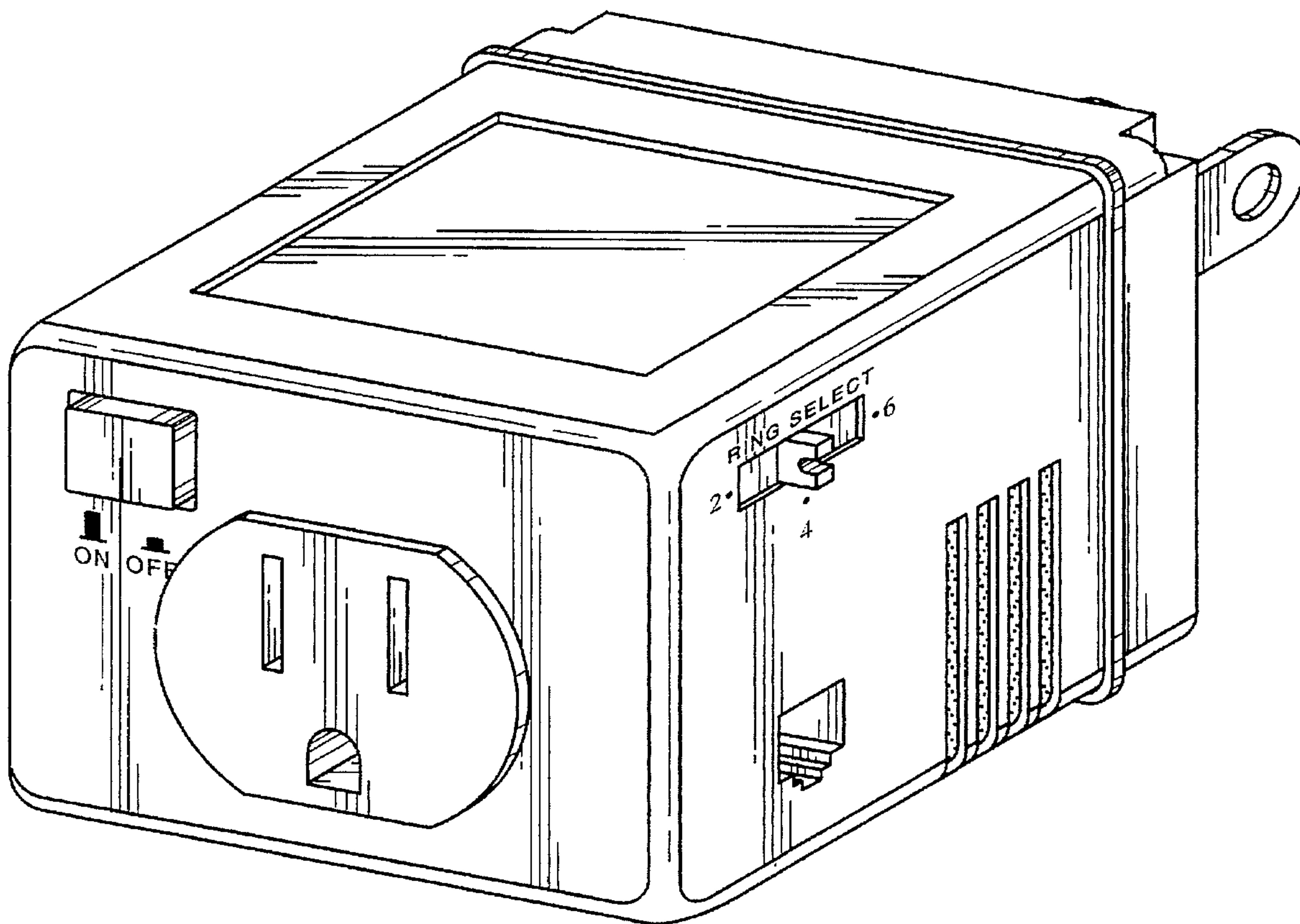

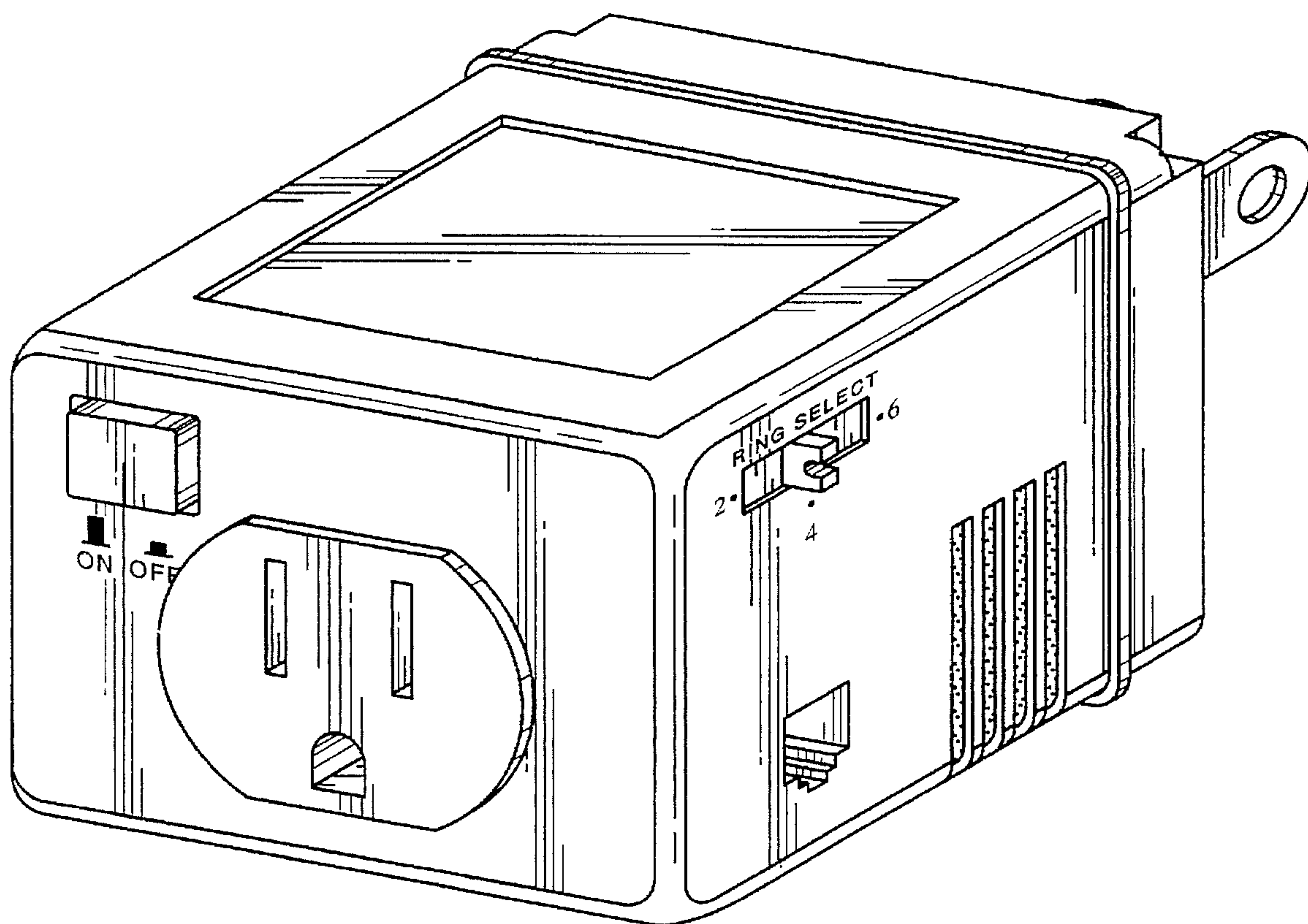

FIG. 1

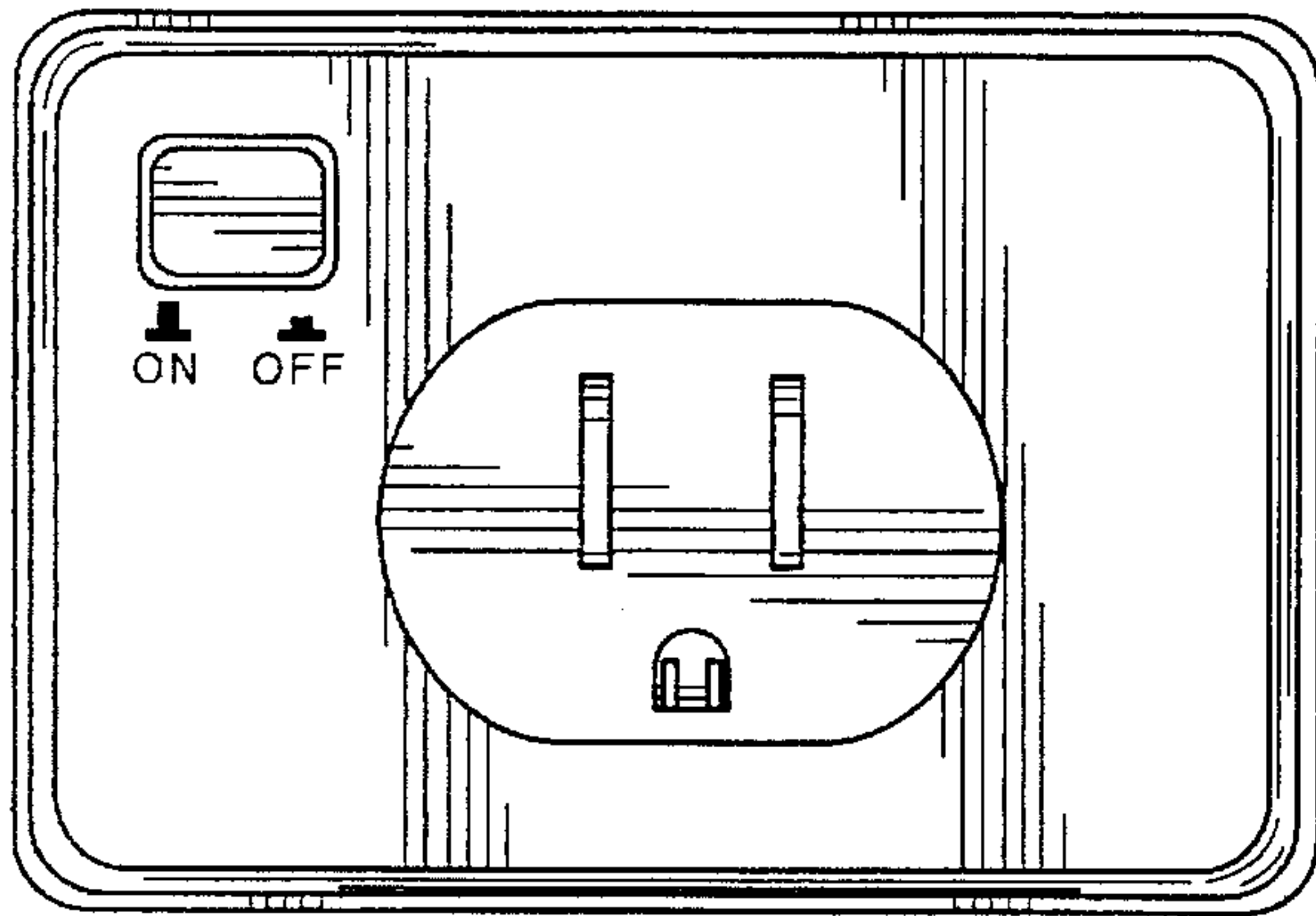

FIG. 2

FIG. 3

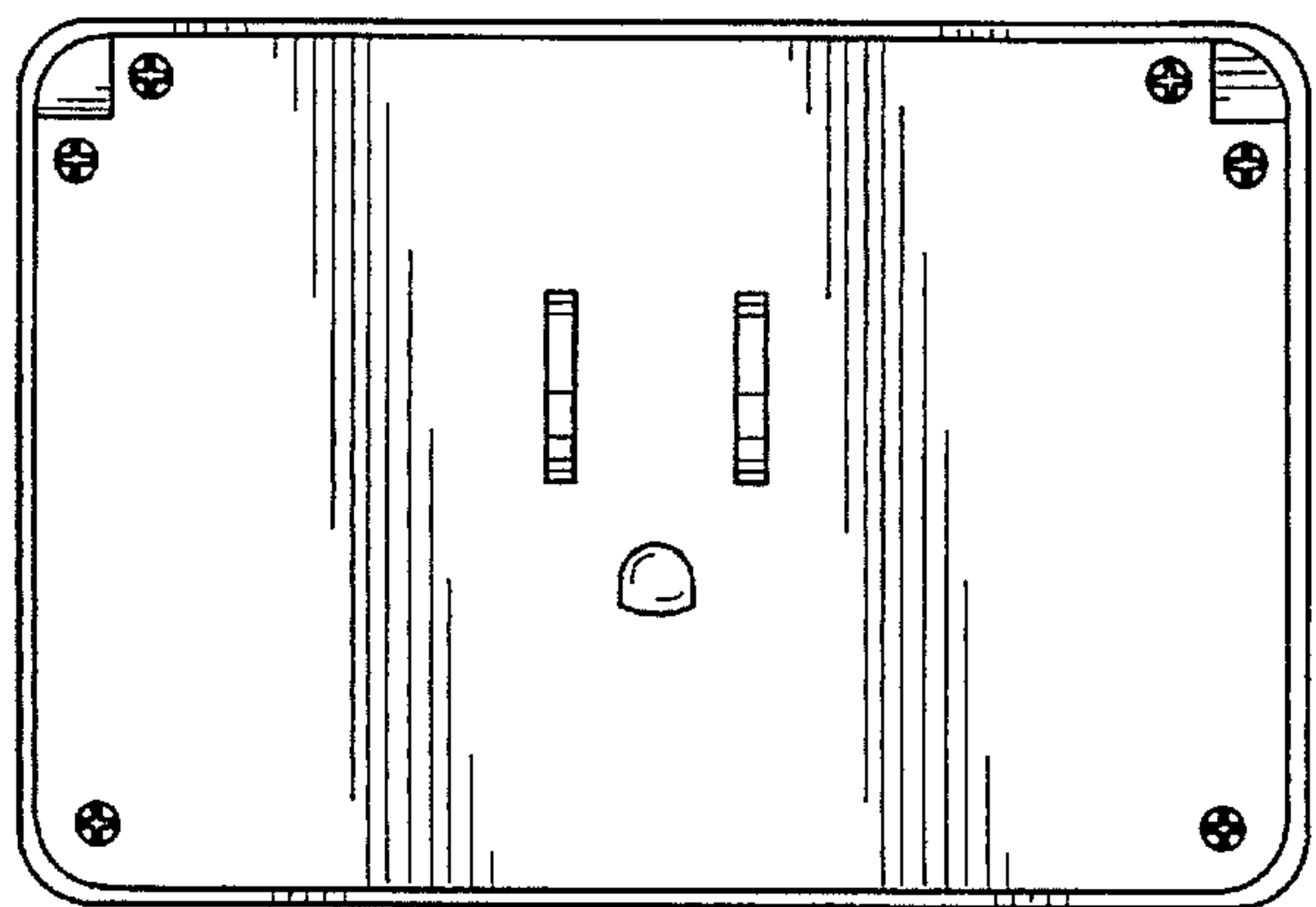

FIG. 4

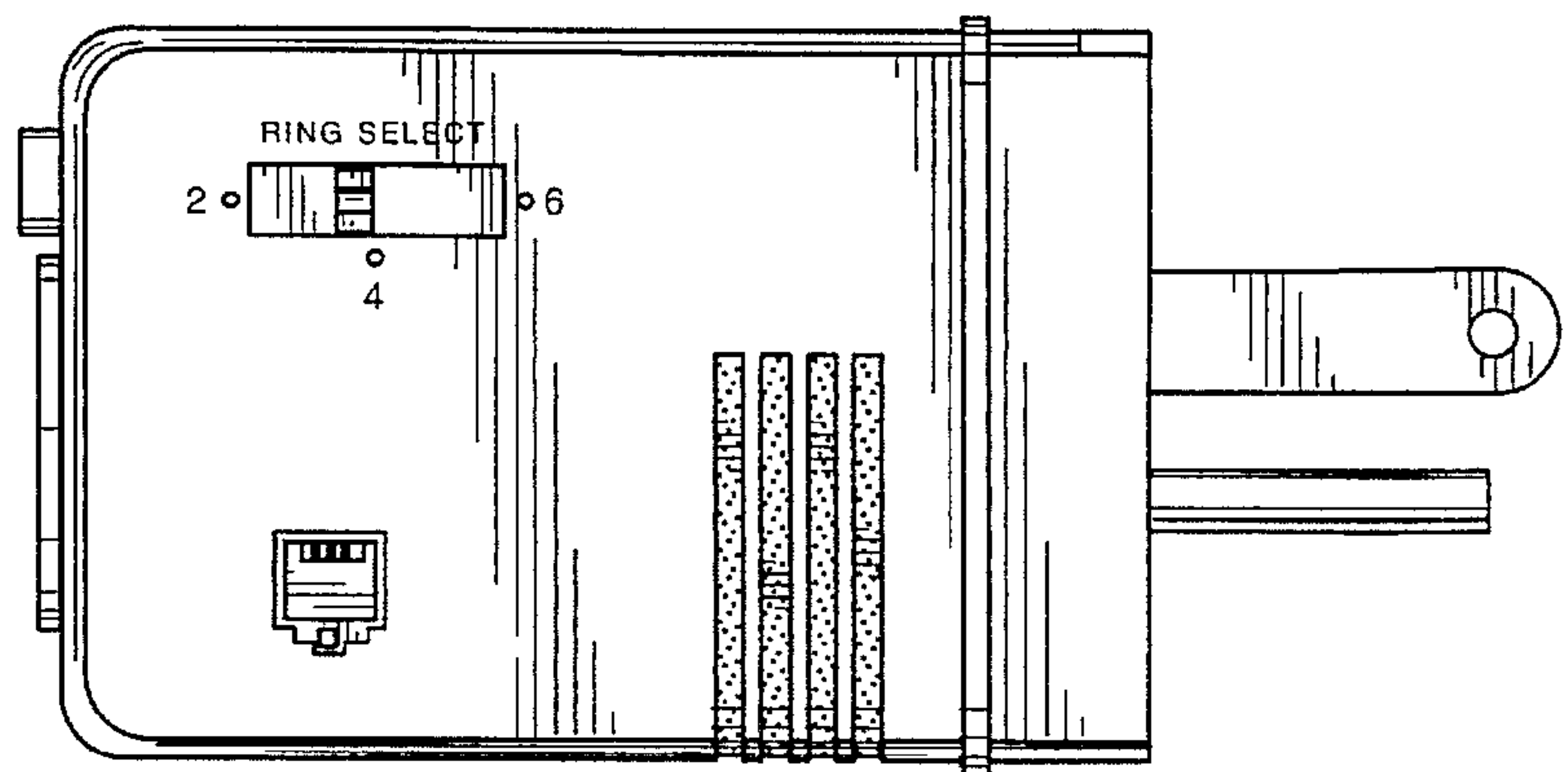
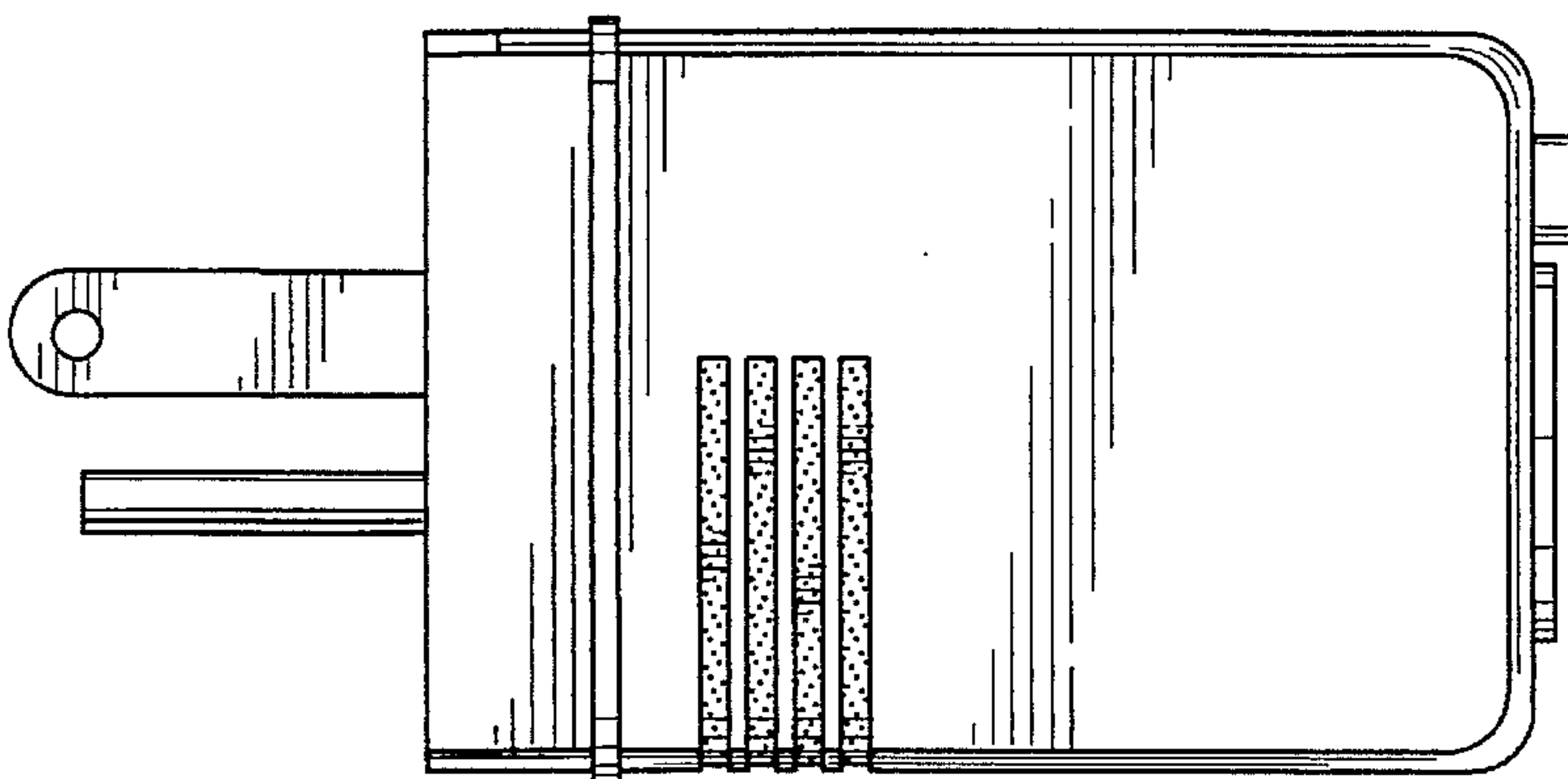

FIG. 5



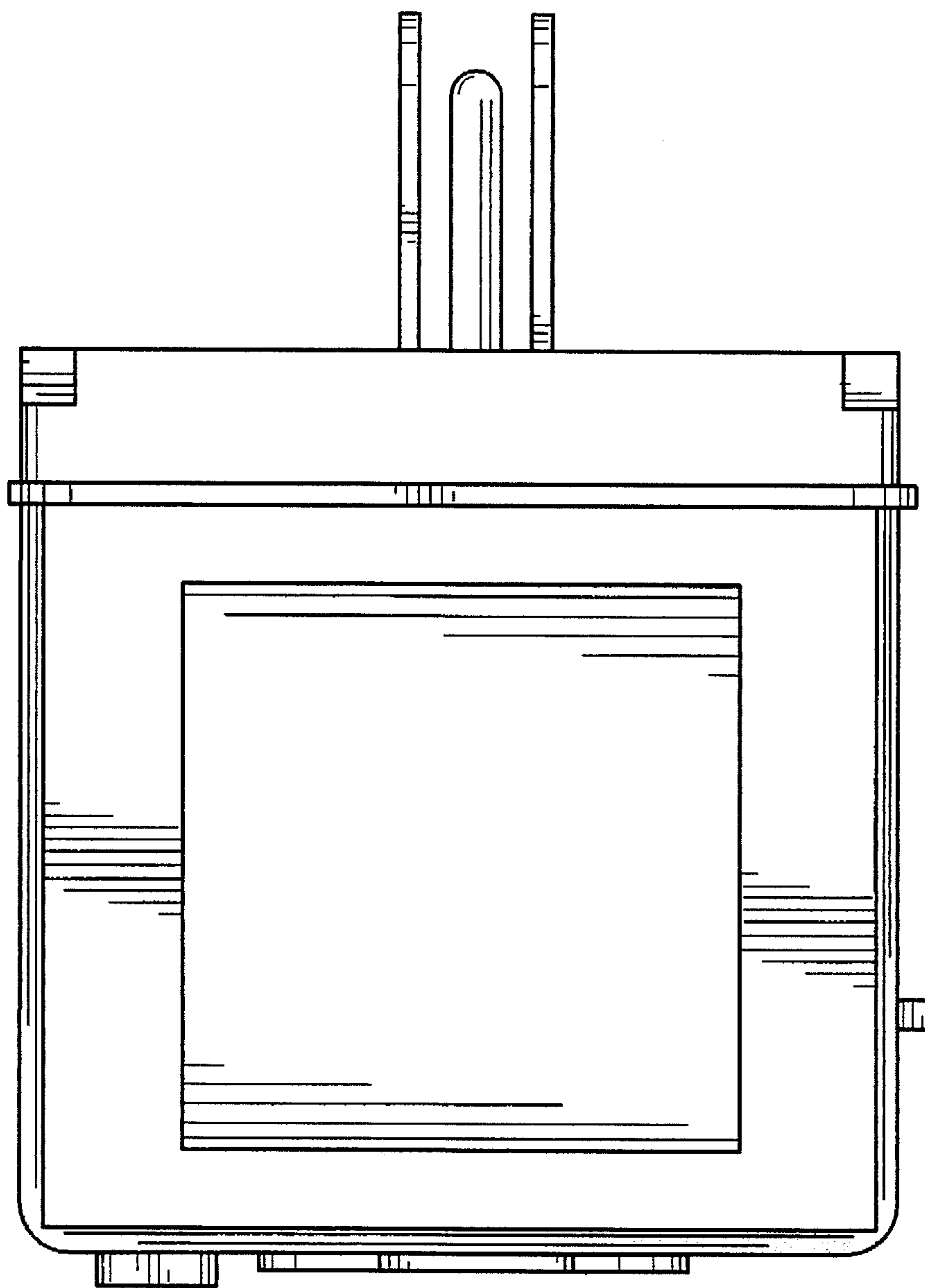

FIG. 6



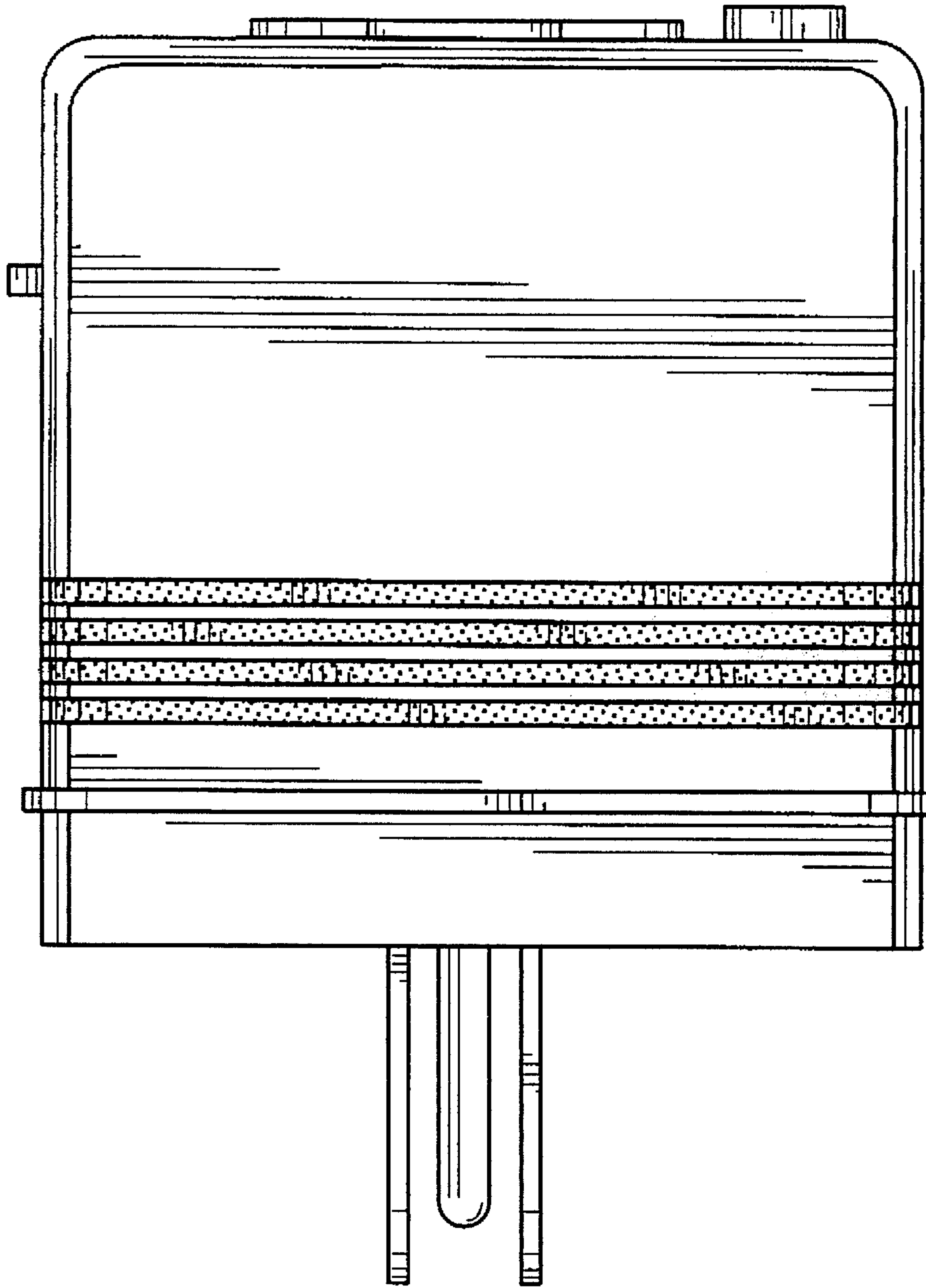

FIG. 7