



US00D379951S

**United States Patent** [19]  
**Kirby et al.**

[11] **Patent Number: Des. 379,951**  
[45] **Date of Patent: \*\*Jun. 17, 1997**

[54] **AUTOMATIC SAFETY BRAKE FOR BABY CARRIAGES**

[76] Inventors: **Robert Kirby; Linda T. Kirby**, both of  
9 Rosemont Dr., New City, N.Y. 10956

[\*\*] Term: **14 Years**

[21] Appl. No.: **53,710**

[22] Filed: **Apr. 26, 1996**

[51] **LOC (6) Cl. .... 12-12**

[52] **U.S. Cl. .... D12/133; D34/27**

[58] **Field of Search .... D12/133, 129;  
D34/27; 280/33, 994, 47.34; 188/20**

[56] **References Cited**

**U.S. PATENT DOCUMENTS**

3,501,164	3/1970	Peterson .....	280/33.994
5,046,748	9/1991	Oat-Judge .....	280/33.994
5,288,089	2/1994	Bowers et al. ....	280/33.994
5,370,408	12/1994	Eagan .....	280/33.994
5,390,942	2/1995	Schusler et al. ....	280/33.994

*Primary Examiner*—**Kay H. Chin**

*Attorney, Agent, or Firm*—**Harold H. Dutton, Jr.; W. Charles L. Jamison; Diane F. Liebman**

[57] **CLAIM**

The ornamental design for an automatic safety brake for baby carriages, as shown and described.

**DESCRIPTION**

FIG. 1 is a perspective view of an automatic safety brake for baby carriages showing our new design;  
 FIG. 2 is a perspective view of the brake portion thereof;  
 FIG. 3 is a front view thereof;  
 FIG. 4 is a rear view thereof;  
 FIG. 5 is a left view thereof;  
 FIG. 6 is a right view thereof;  
 FIG. 7 is a top view thereof;  
 FIG. 8 is a bottom view thereof;  
 FIG. 9 is a perspective view of the brake release handle portion thereof;  
 FIG. 10 is a front view thereof;  
 FIG. 11 is a rear view thereof;  
 FIG. 12 is a left view thereof;  
 FIG. 13 is a right view thereof;  
 FIG. 14 is a top view thereof; and,  
 FIG. 15 is a bottom view thereof.

The broken lines showing a baby carriage in FIG. 1 are for illustrative purposes only and form no part of the claimed design.

**1 Claim, 9 Drawing Sheets**

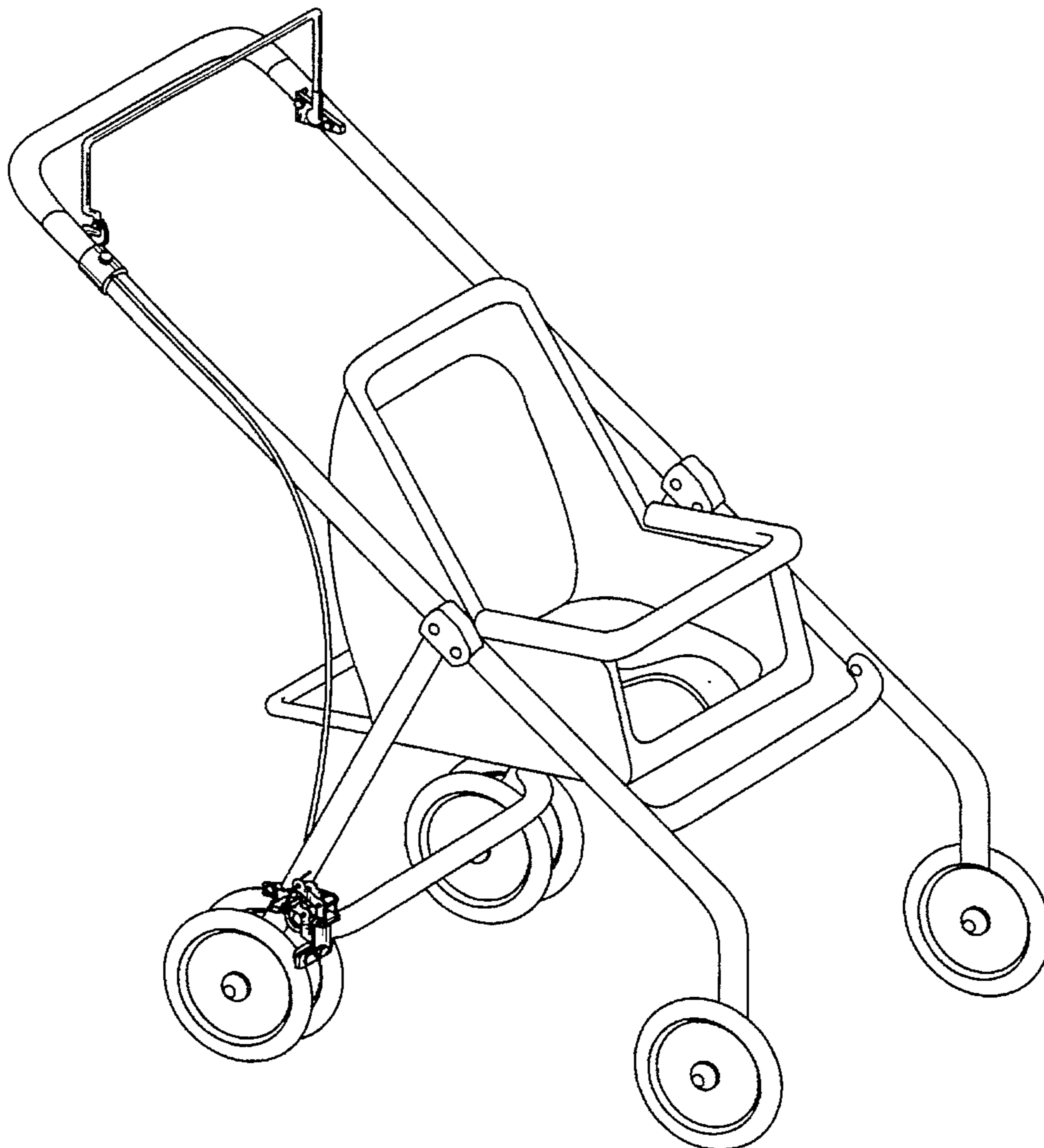

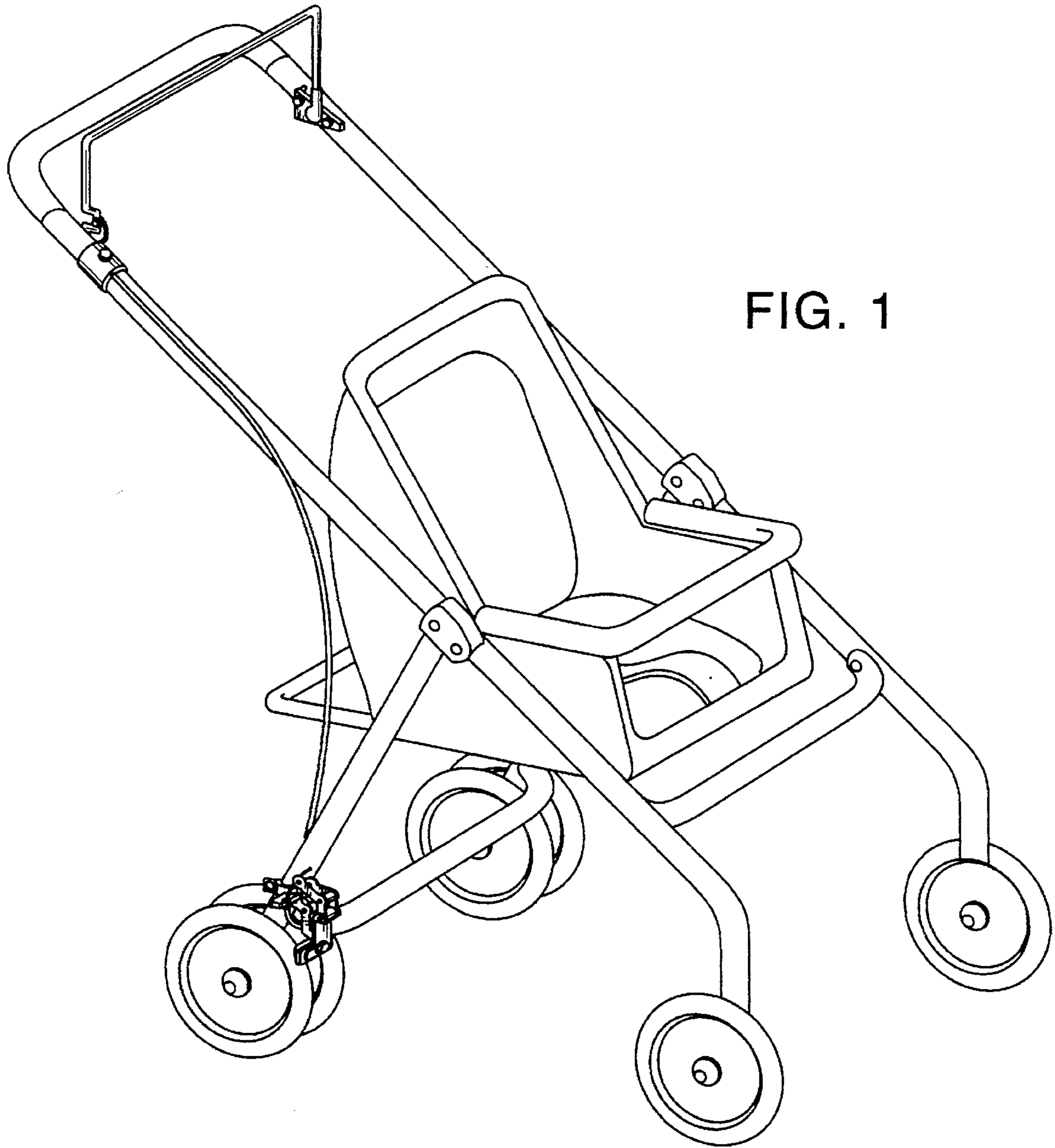

FIG. 1

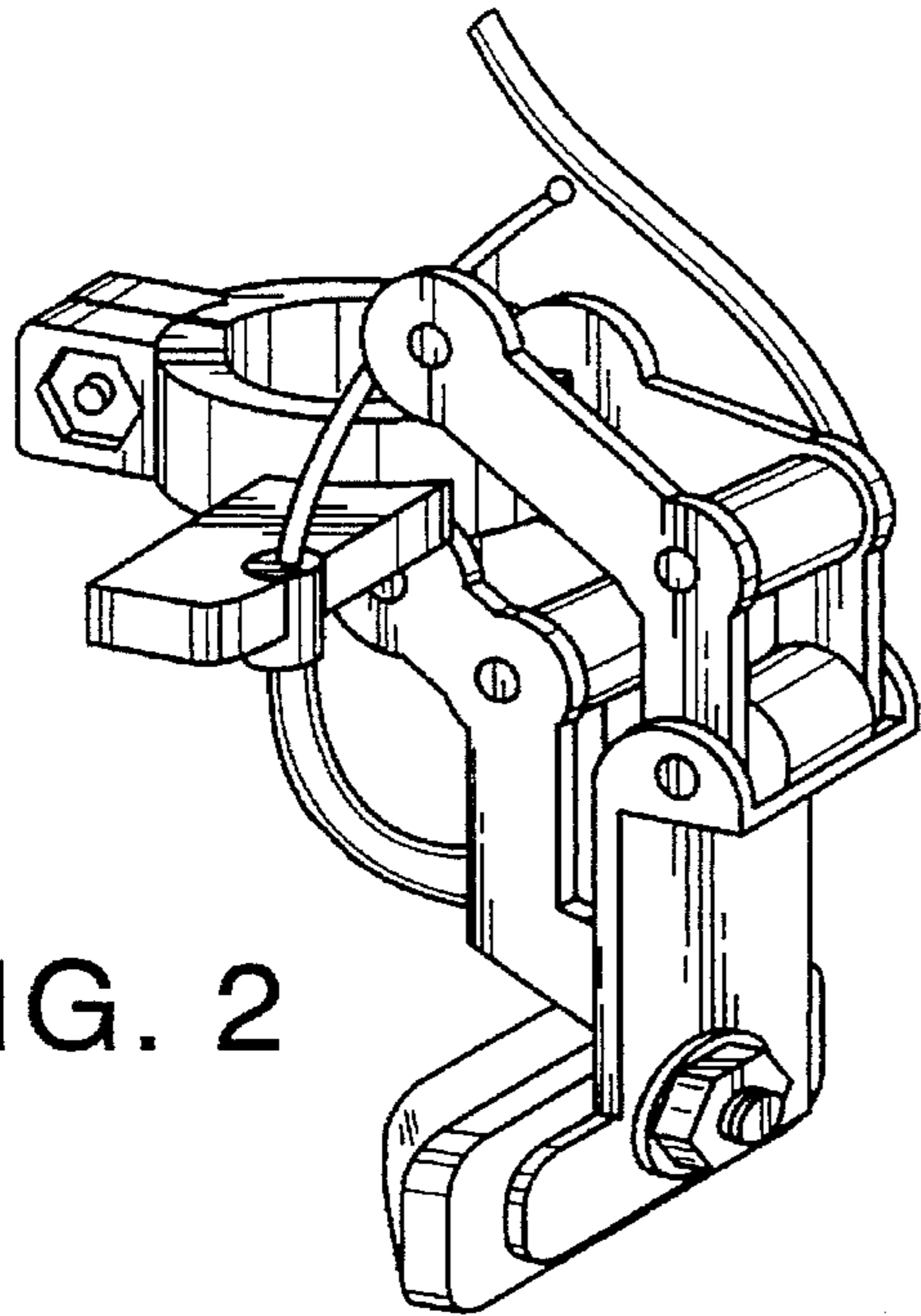

FIG. 2

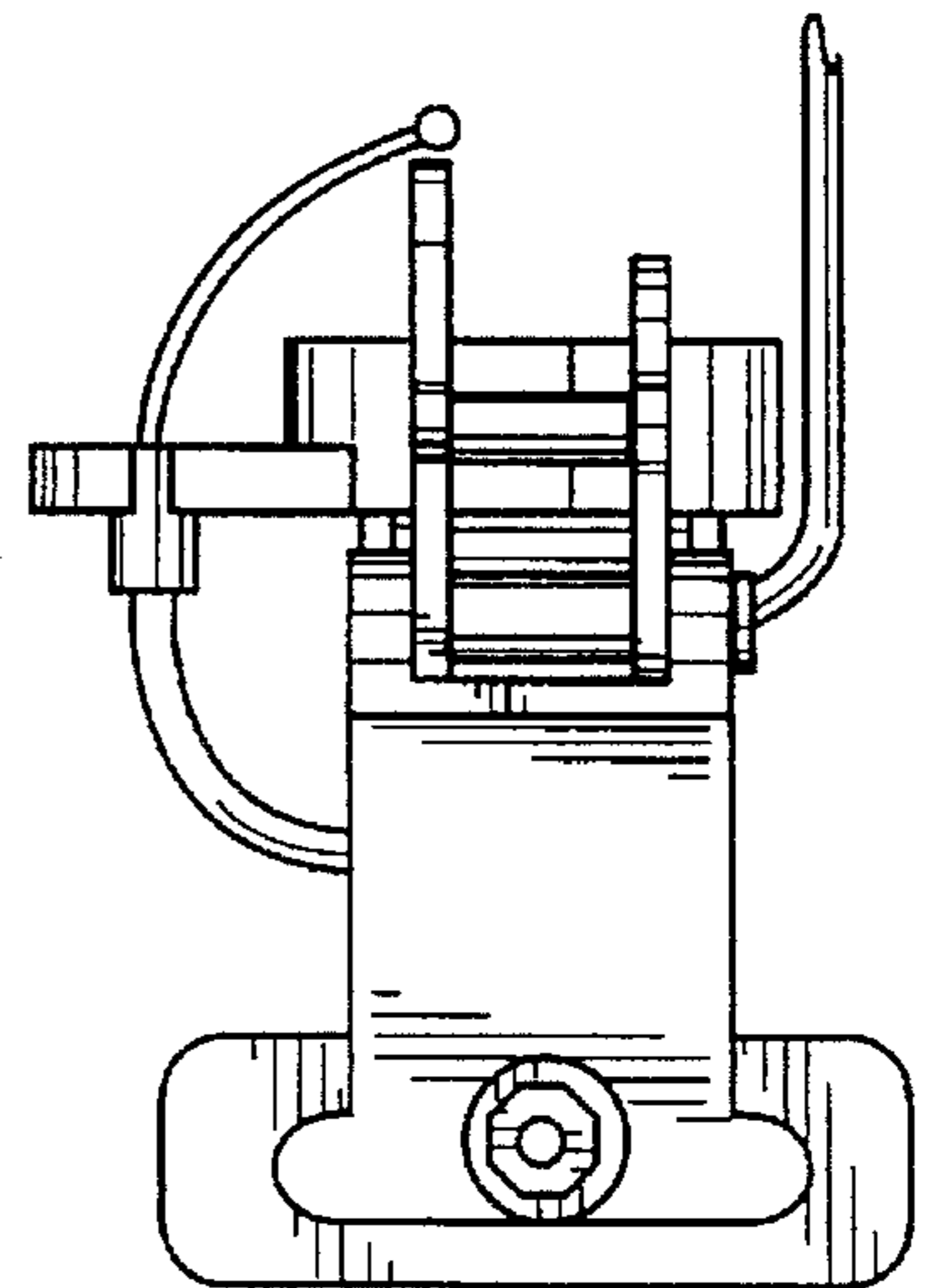

FIG. 3

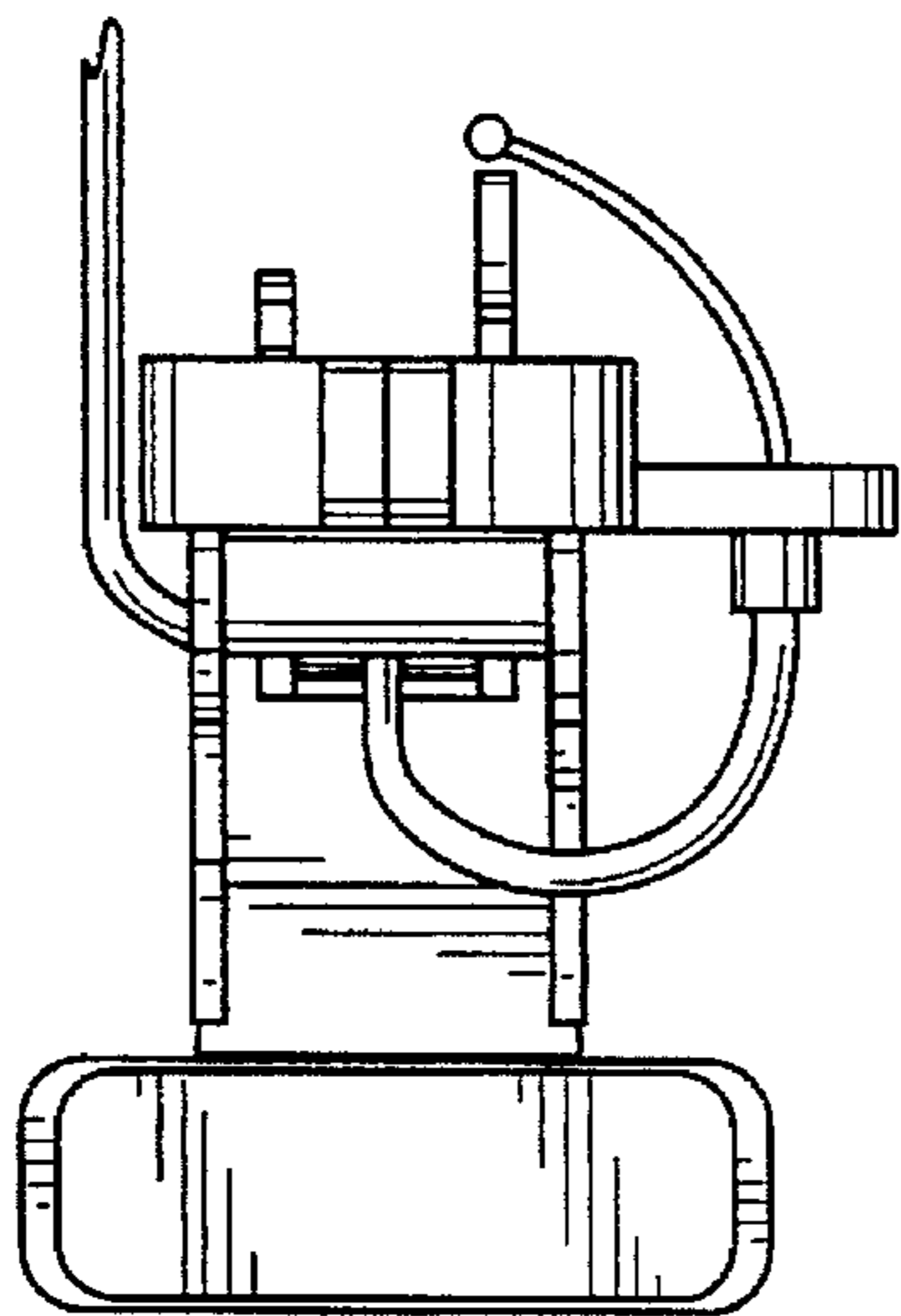

FIG. 4

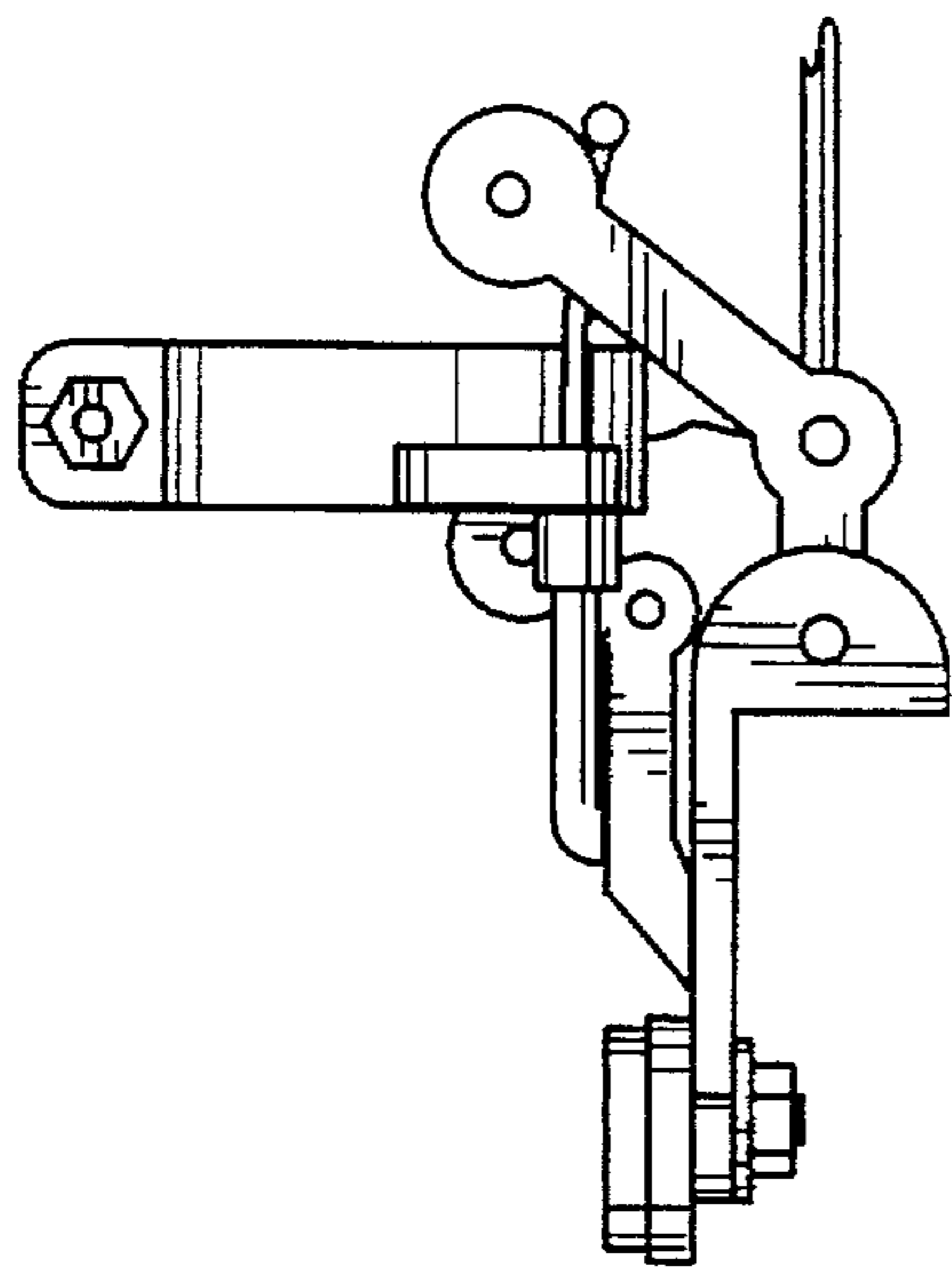

FIG. 5

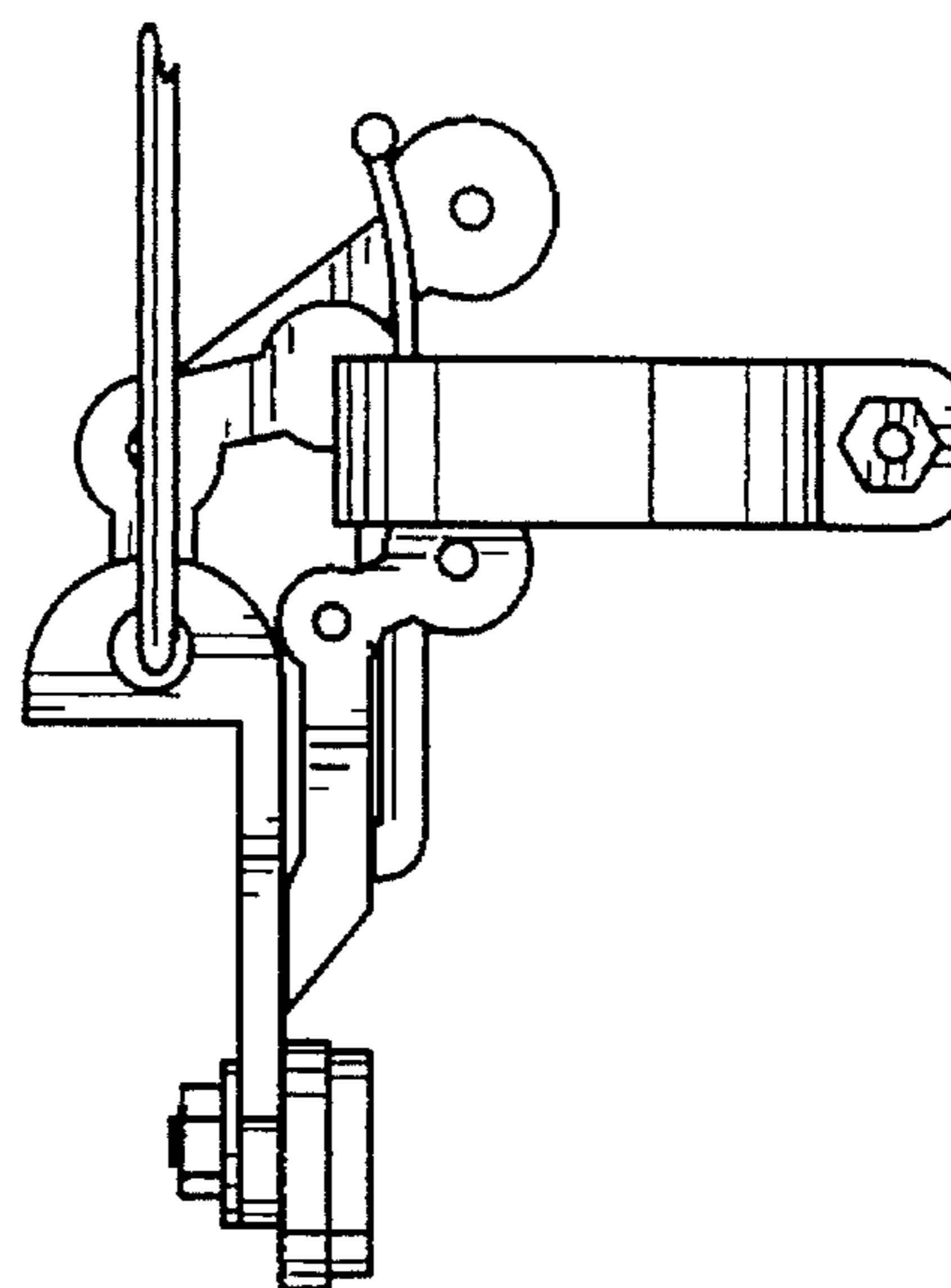

FIG. 6

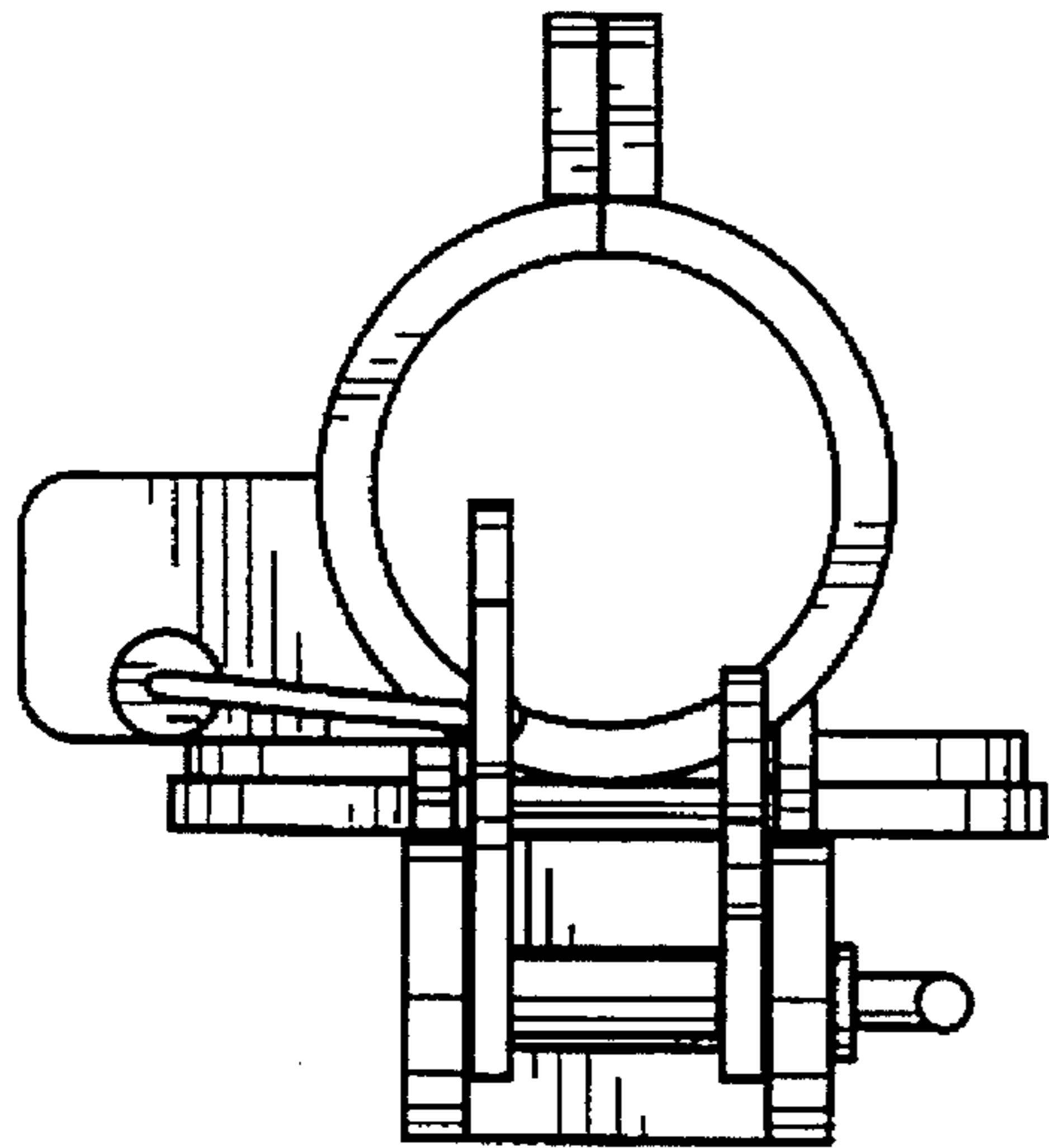
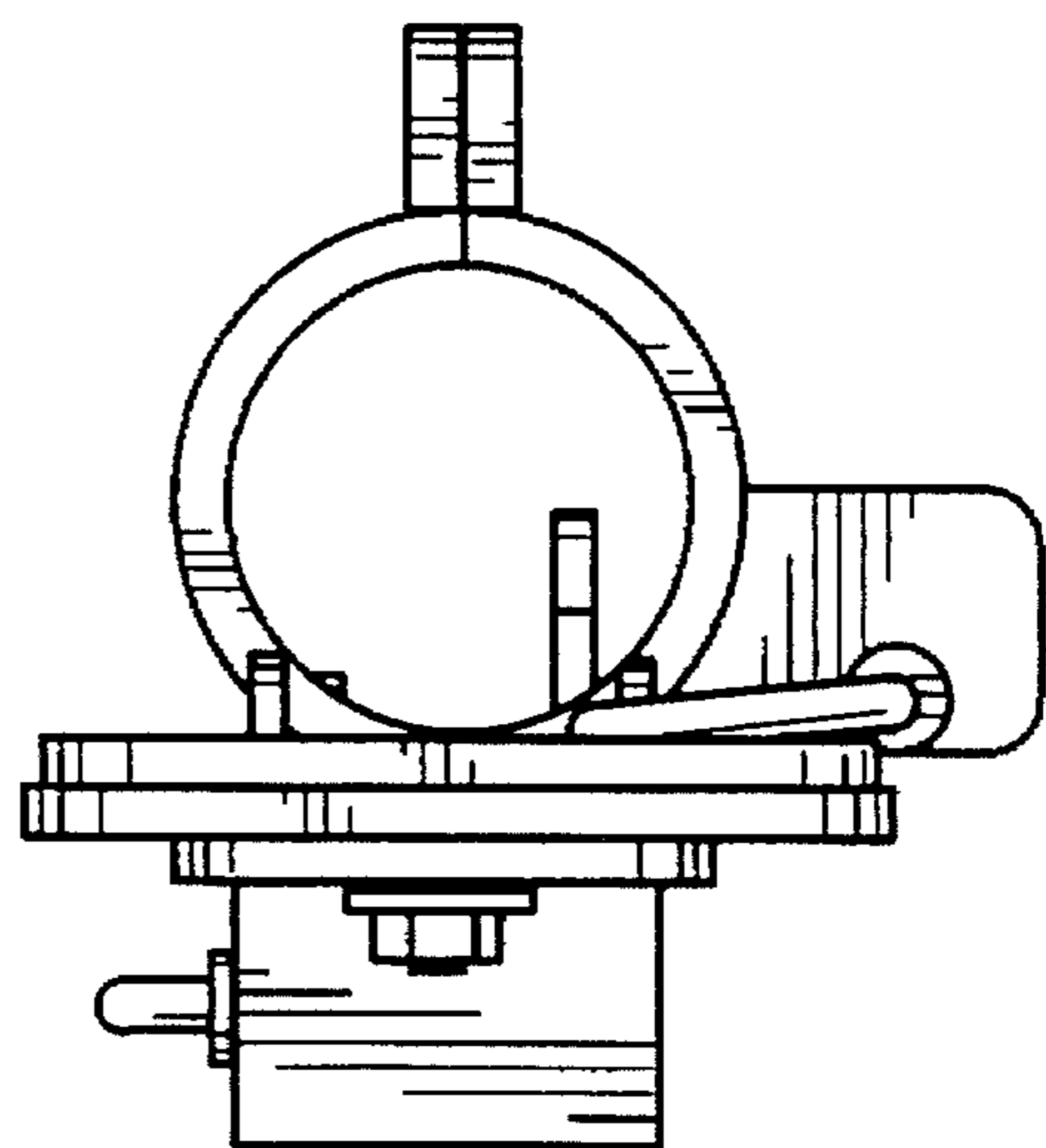

FIG. 7

FIG. 8





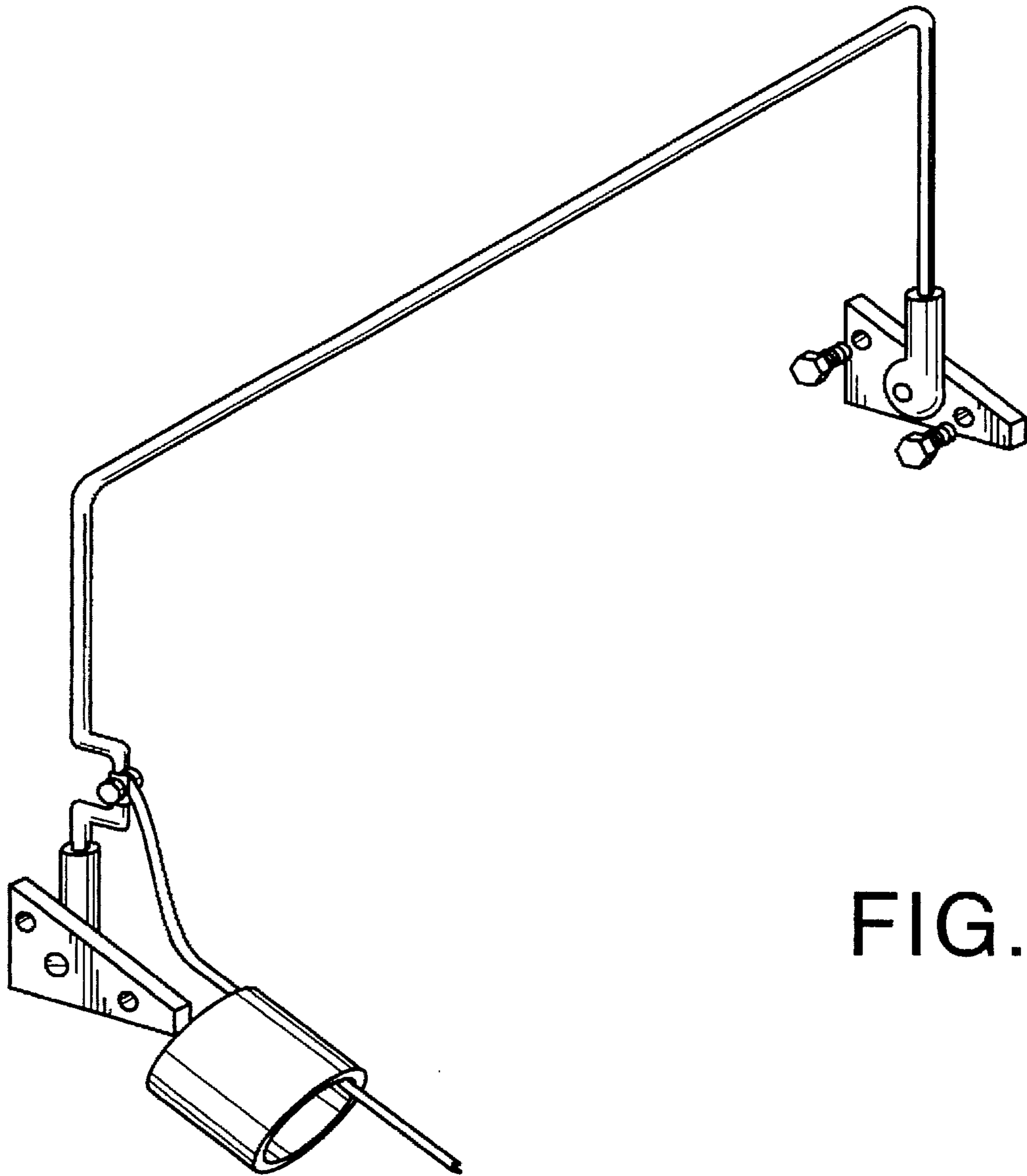

FIG. 9

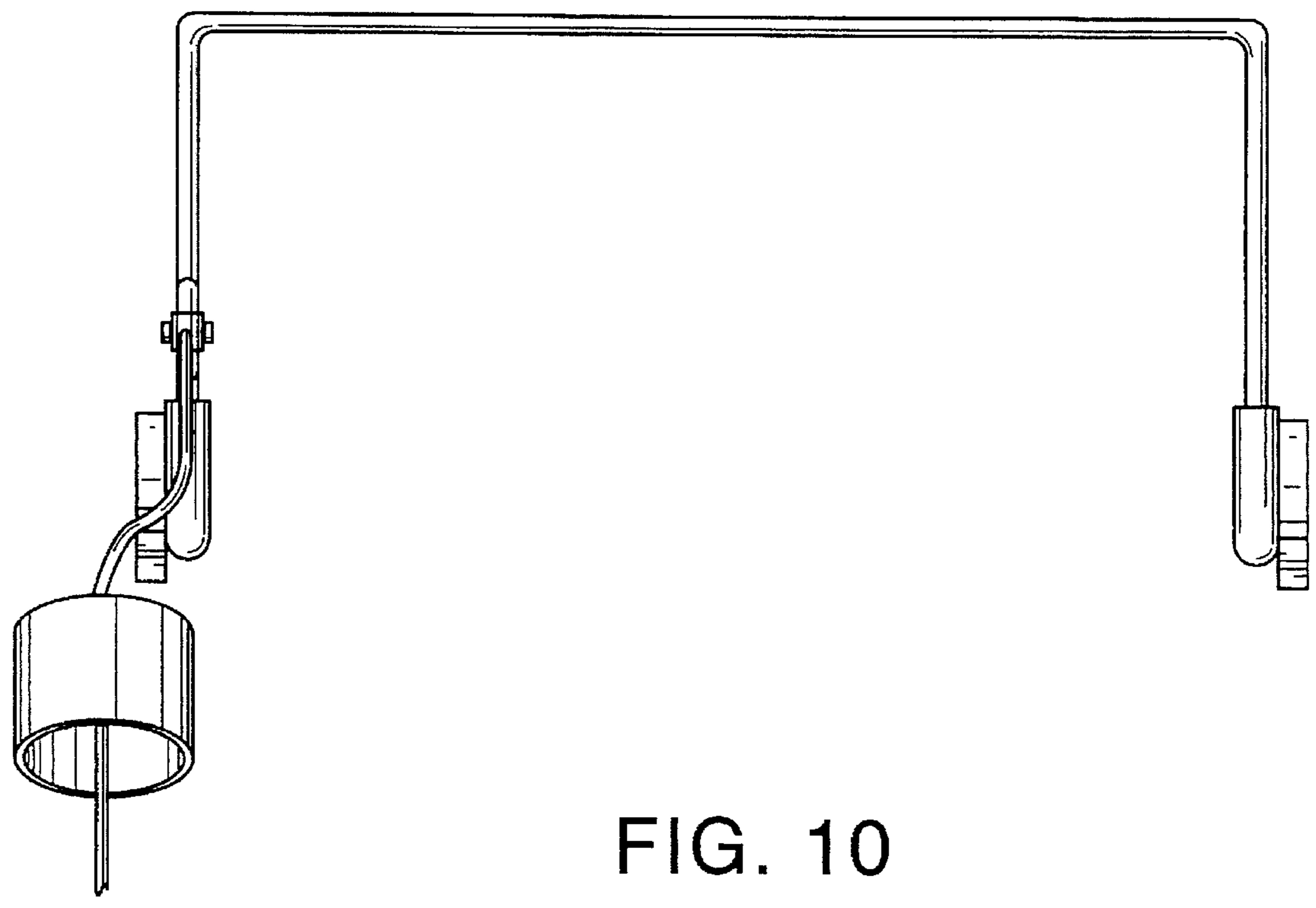

FIG. 10

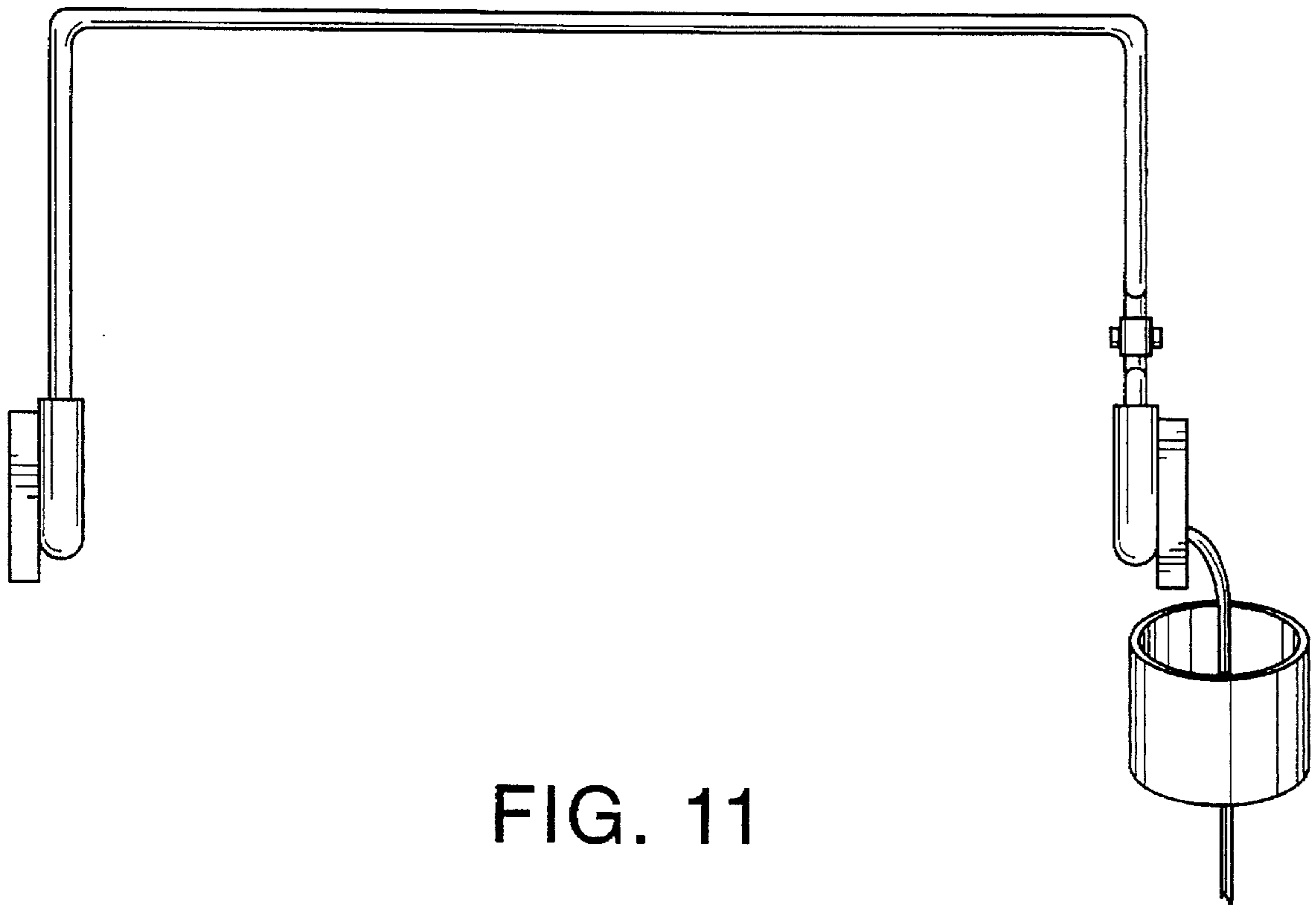

FIG. 11



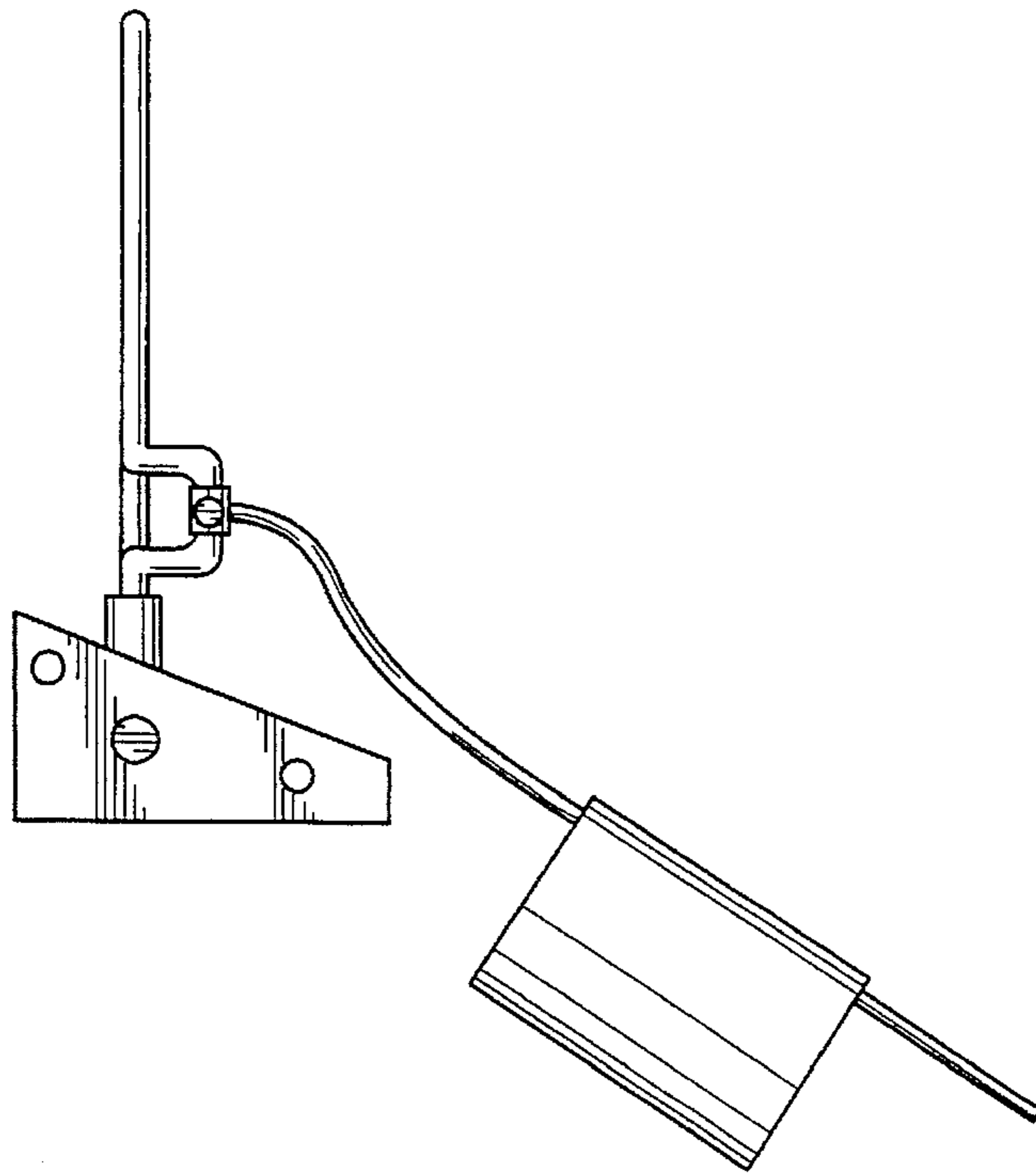

FIG. 12

FIG. 13

