



US00D379870S

United States Patent [19]

[11] Patent Number: **Des. 379,870**

Moneta

[45] Date of Patent: *****Jun. 17, 1997**

[54] **COMBINED SKI EQUIPMENT TRANSPORT AND STORAGE CASE**

D. 362,115	9/1995	Moneta	D3/261
D. 367,169	2/1996	Vincent	D3/261
4,161,268	7/1979	Heil	206/315.1
4,953,773	9/1990	Wirth	206/315.1 X
5,096,104	3/1992	Wirth	224/202 X

[76] Inventor: **John E. Moneta**, 2138 149th Ave. NE., Ham Lake, Minn. 55304

[*] Notice: The portion of the term of this patent subsequent to Sep. 12, 2009, has been disclaimed.

Primary Examiner—Doris V. Coles
Assistant Examiner—Catherine R. Oliver

[**] Term: **14 Years**

[57] **CLAIM**

[21] Appl. No.: **40,172**

The ornamental design for a combined ski equipment transport and storage case, as shown and described.

[22] Filed: **Jun. 12, 1995**

DESCRIPTION

Related U.S. Application Data

FIG. 1 is a perspective view particularly illustrating top-rear case sides of a combined ski equipment transport and storage embodying my design;

[63] Continuation-in-part of Ser. No. 6,328, Mar. 22, 1993, Pat. No. Des. 362,115.

FIG. 2 is a perspective view particularly illustrating bottom-front sides;

[51] **LOC (6) Cl.** **03-01**

[52] **U.S. Cl.** **D3/261**

[58] **Field of Search** D3/261, 204, 254, D3/904, 905, 272, 262, 282; 224/202, 917; 206/315.1, 315.11, 317

FIG. 3 is a front elevational view;

FIG. 4 is a rear elevational view, opposite the front view of FIG. 3;

FIG. 5 is a top plan view looking at the handle side of FIG. 3;

FIG. 6 is a bottom plan view, opposite that of FIG. 5;

FIG. 7 is an end elevational view as seen from the right side of FIG. 4; and,

FIG. 8 is an end elevational view as seen from the left side of FIG. 4.

[56] **References Cited**

U.S. PATENT DOCUMENTS

D. 257,913	1/1981	O'Dair	D3/261
D. 321,430	11/1991	Wirth	D3/261
D. 332,695	1/1993	Moscovitch	D3/261

1 Claim, 4 Drawing Sheets

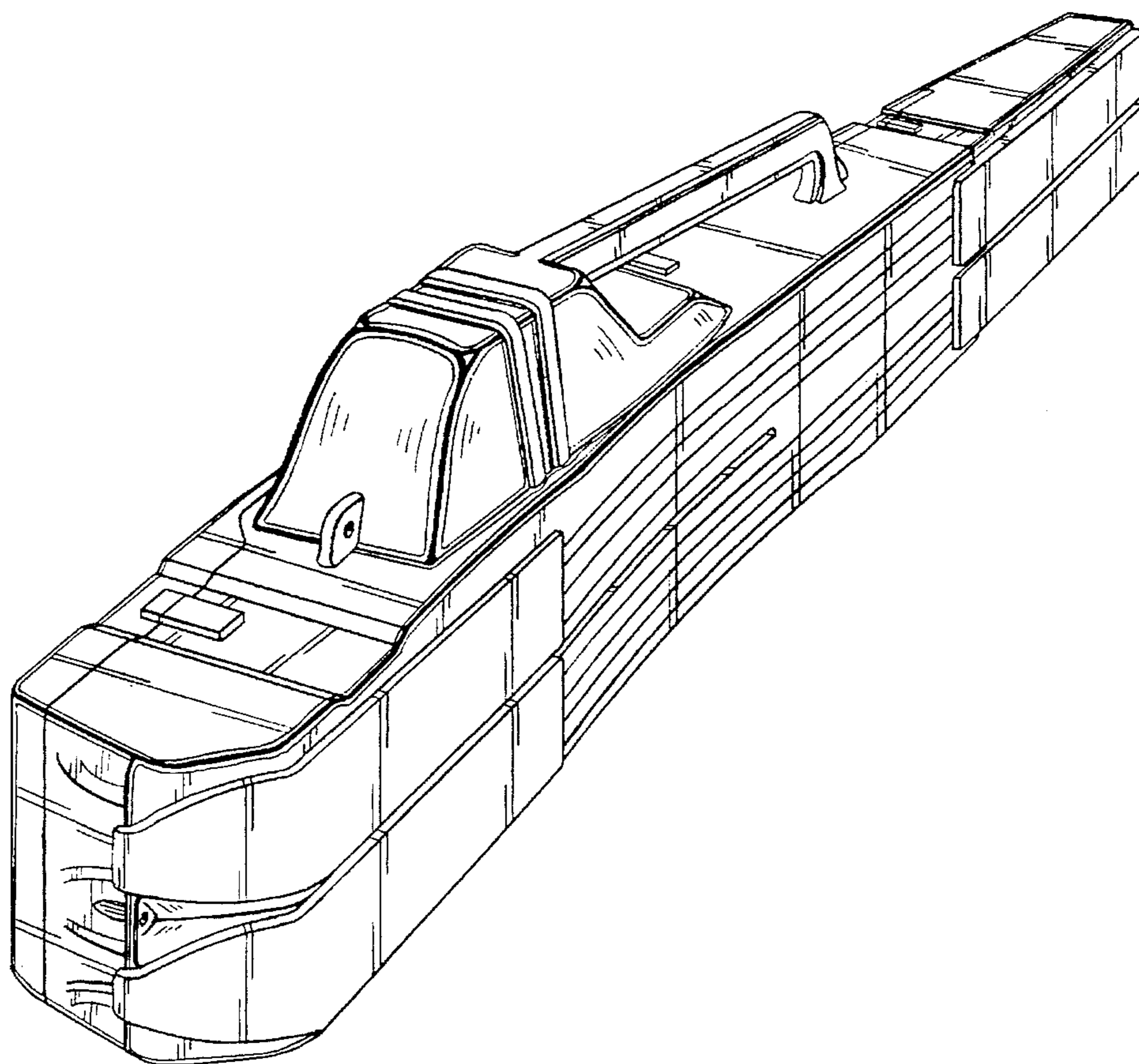

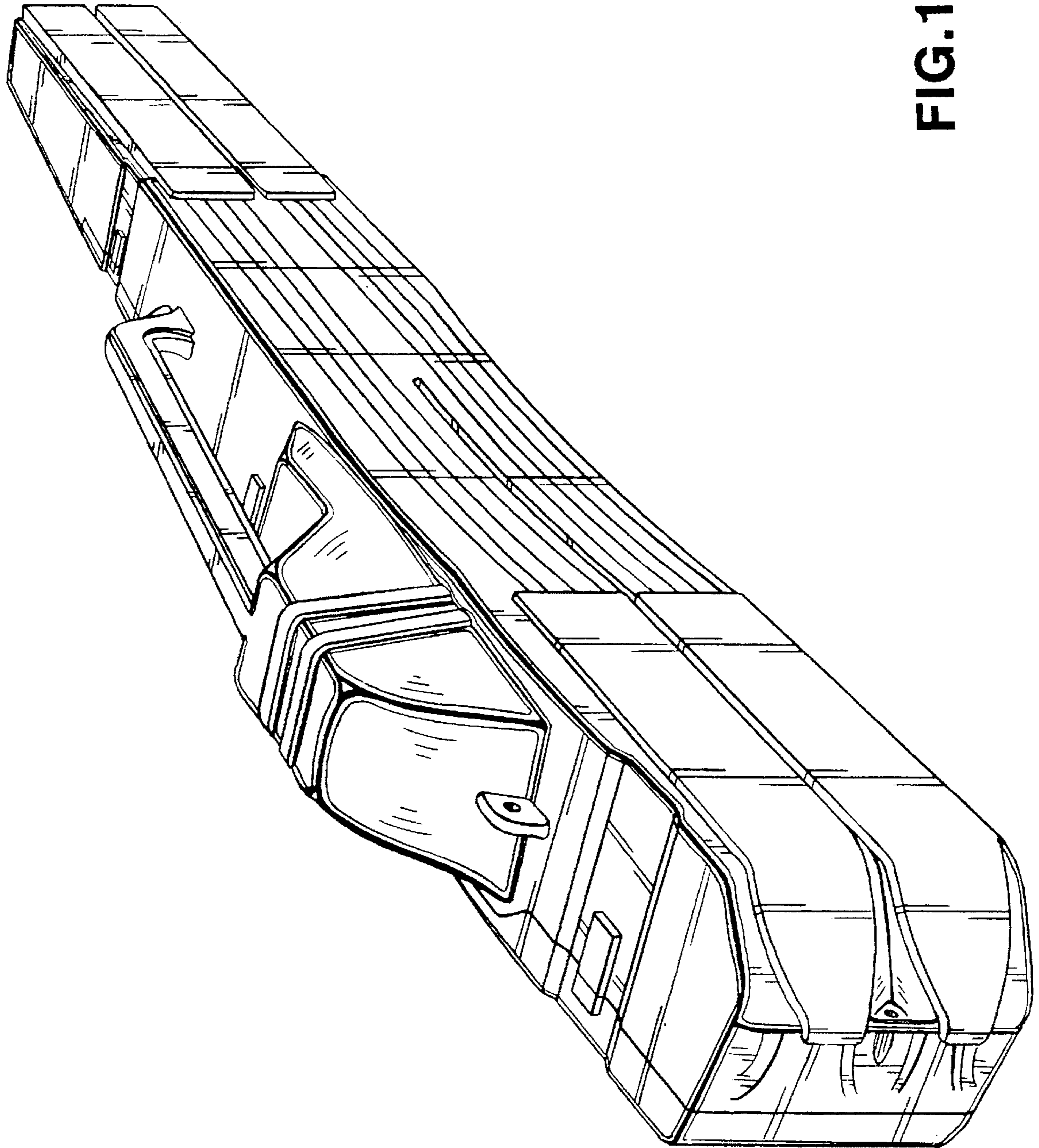

FIG.1

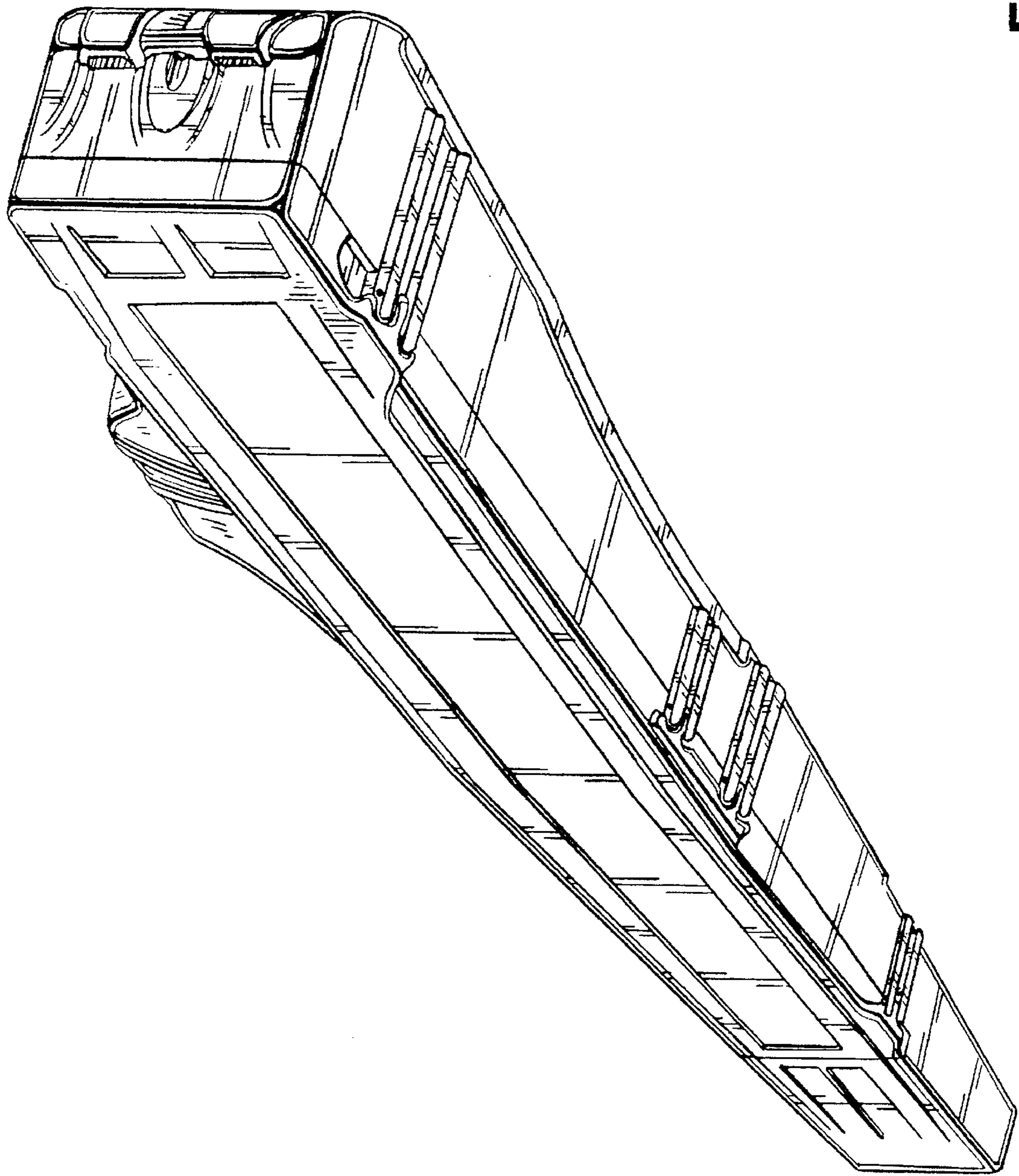

FIG.2

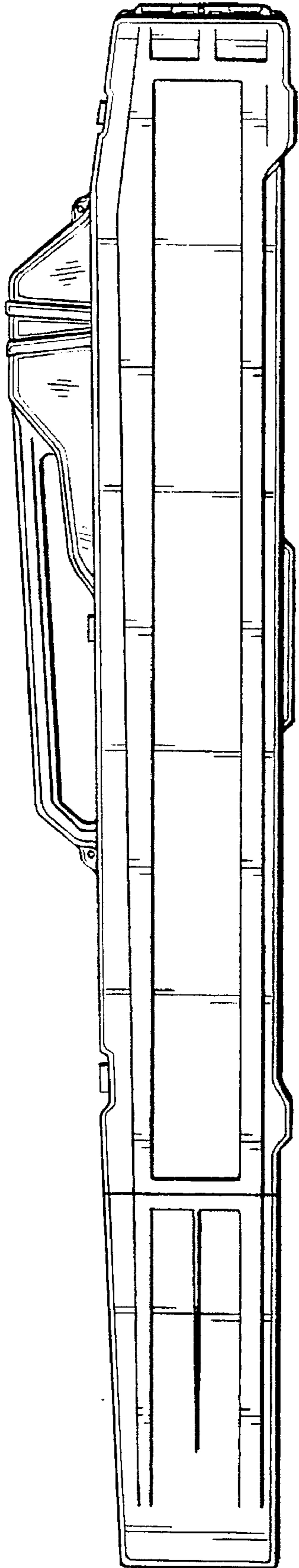

FIG. 3

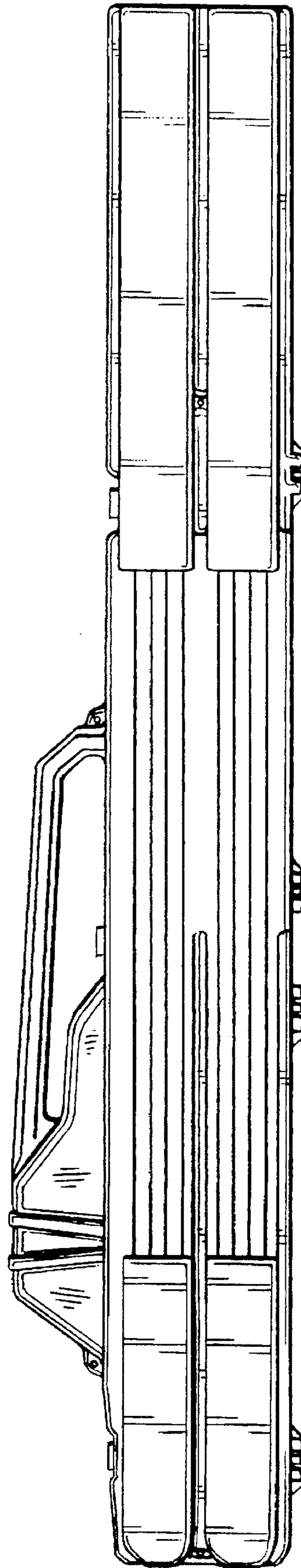

FIG. 4

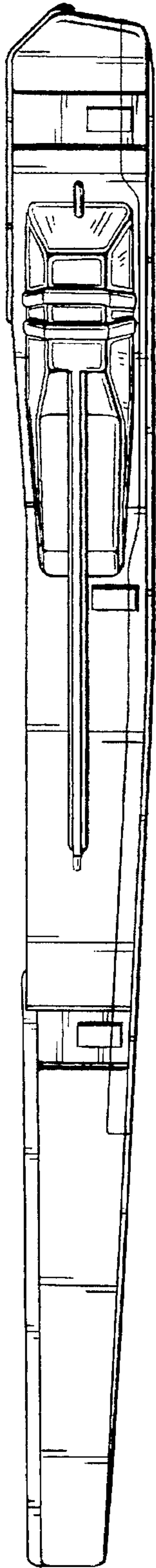

FIG. 5

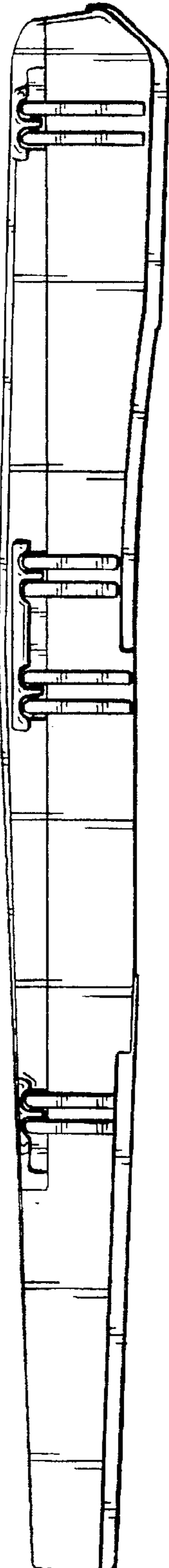

FIG. 6

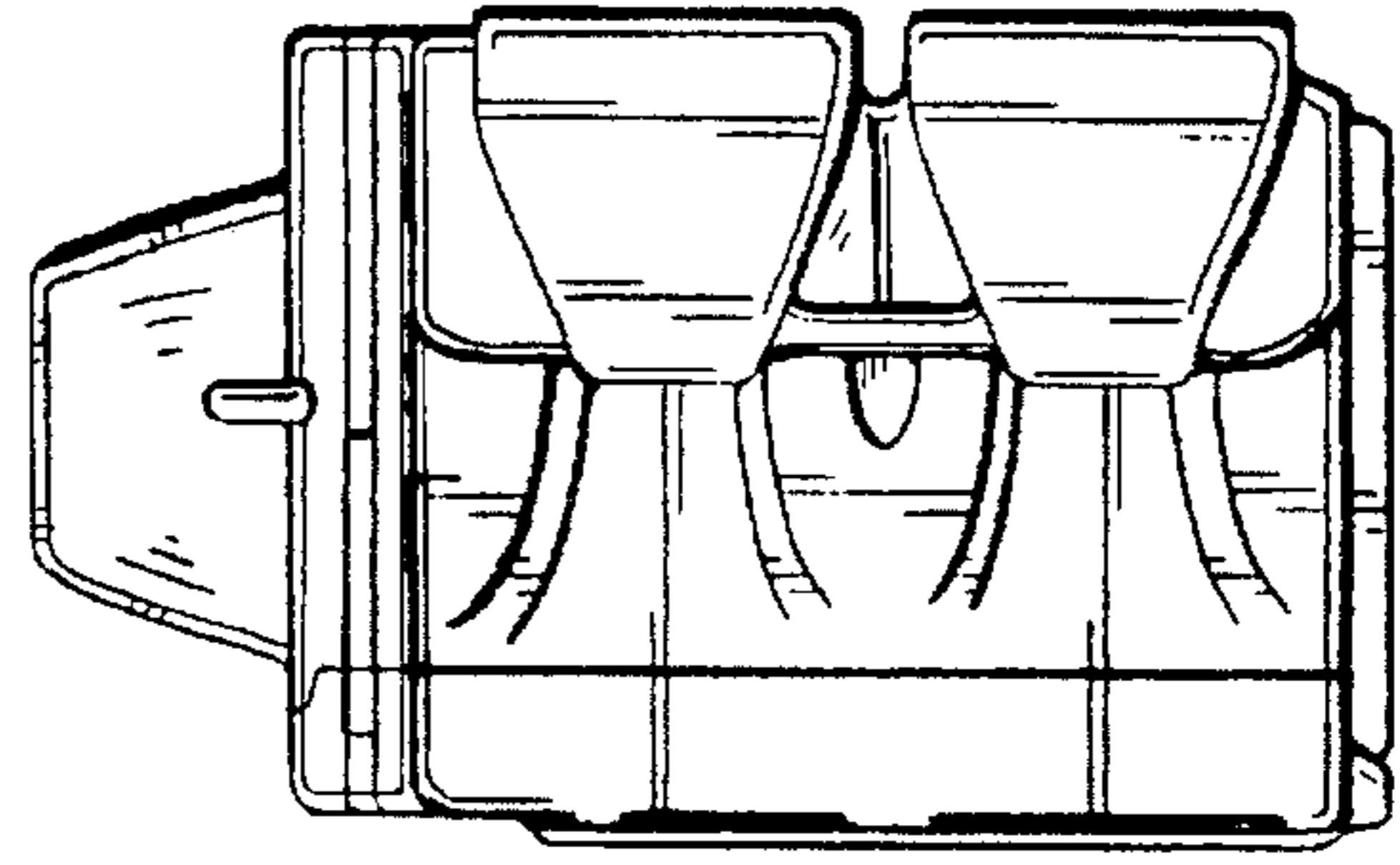

FIG. 7

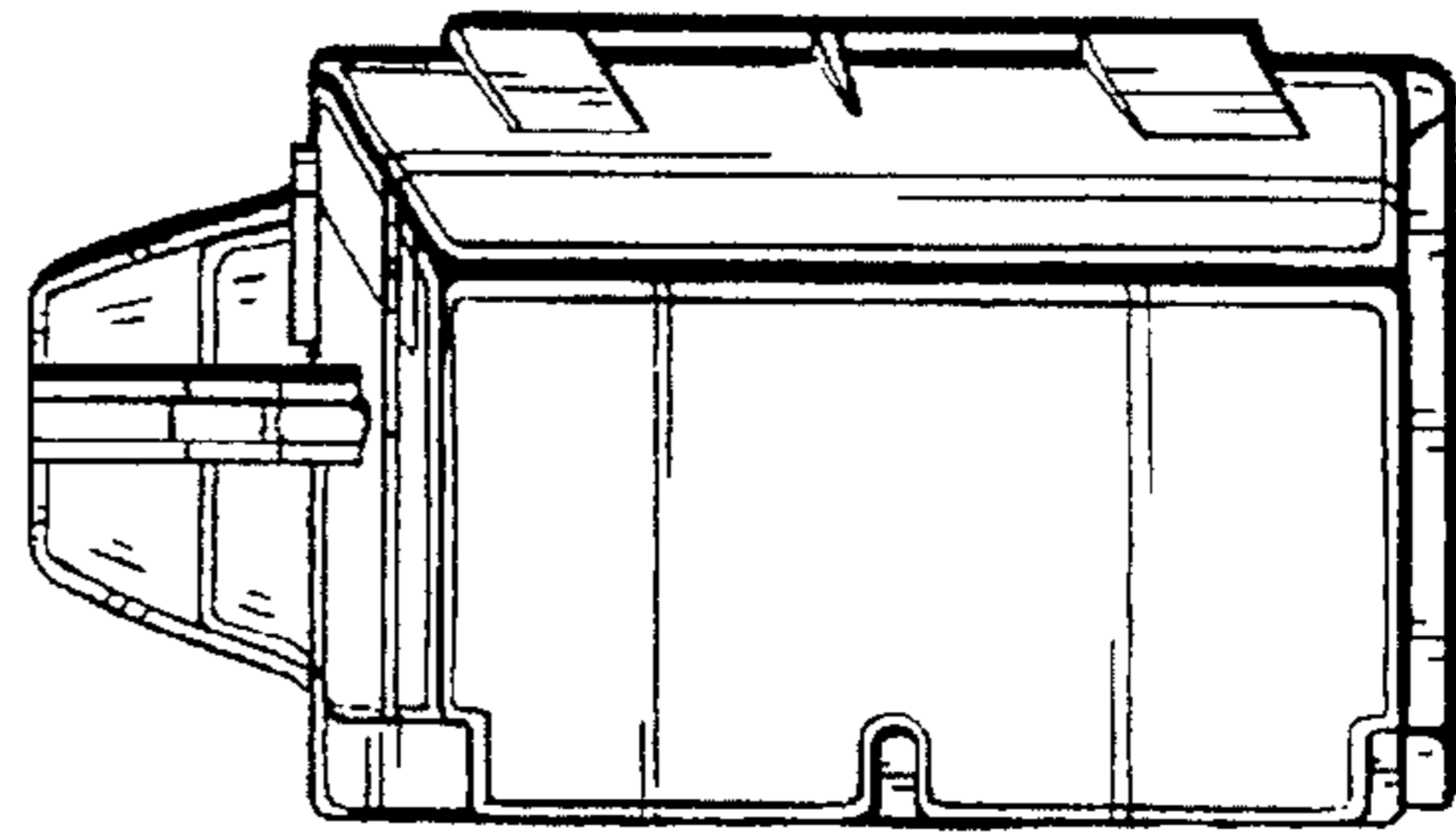

FIG. 8