



US00D379854S

United States Patent [19]

Hirsch et al.

[11] Patent Number: Des. 379,854

[45] Date of Patent: **Jun. 10, 1997

[54] FEEDING TUBE

[75] Inventors: William H. Hirsch, Gahanna; Donald J. Goldhardt, Grove City, both of Ohio

[73] Assignee: Abbott Laboratories, Abbott Park, Ill.

[**] Term: 14 Years

[21] Appl. No.: 18,406

[22] Filed: Feb. 4, 1994

[51] LOC (6) Cl. 24-04

[52] U.S. Cl. D24/112; D24/108

[58] Field of Search D24/108, 112; 604/268, 278, 104, 175, 174, 275, 276, 277, 279, 280, 178, 98, 54, 35, 105, 93

[56] References Cited

U.S. PATENT DOCUMENTS

D. 328,787	8/1992	Picha et al.	D24/108
1,273,665	7/1918	Porter	604/264
4,666,433	5/1987	Parks	604/178
4,758,219	7/1988	Sacks et al.	604/54
4,781,704	11/1988	Potter	D24/112 X
5,007,900	4/1991	Picha et al.	604/106
5,080,650	1/1992	Hirsch et al.	604/104
5,267,969	12/1993	Hirsch et al.	604/174
5,308,325	5/1994	Quinn et al.	604/264 X
5,403,264	4/1995	Wohlers et al.	604/278 X

OTHER PUBLICATIONS

Bard™ Guideware P.E.G. System with Soft Silicone Retention Dome distrib. by C.R. Bard, Inc. Tewksbury, MA Jur. 1990.

Primary Examiner—Doris V. Coles

Assistant Examiner—I. Simmons

Attorney, Agent, or Firm—Brian R. Woodworth

[57] CLAIM

The ornamental design for a feeding tube, as shown and described.

DESCRIPTION

FIG. 1 is a fragmentary perspective view of a feeding tube showing our new design, the tube being broken away to indicate indeterminate length;

FIG. 2 is a second fragmentary perspective view thereof, with the feeding tube inverted from the position shown in FIG. 1;

FIG. 3 is a fragmentary front elevation view thereof, it being understood that the rear elevation view is identical;

FIG. 4 is a fragmentary right side elevation view thereof, it being understood that the left side elevation view is identical;

FIG. 5 is a top view thereof; and

FIG. 6 is a bottom view thereof;

FIG. 7 is a fragmentary perspective view of a second embodiment of a feeding tube showing our new design, the tube being broken away to indicate indeterminate length;

FIG. 8 is a second fragmentary perspective view thereof, with the feeding tube inverted from the position shown in FIG. 7;

FIG. 9 is a fragmentary front elevation view thereof;

FIG. 10 is a fragmentary right side elevation view thereof, it being understood that the left side elevation view is identical;

FIG. 11 is a fragmentary rear elevation view thereof;

FIG. 12 is a top view thereof; and,

FIG. 13 is a bottom view thereof.

1 Claim, 4 Drawing Sheets

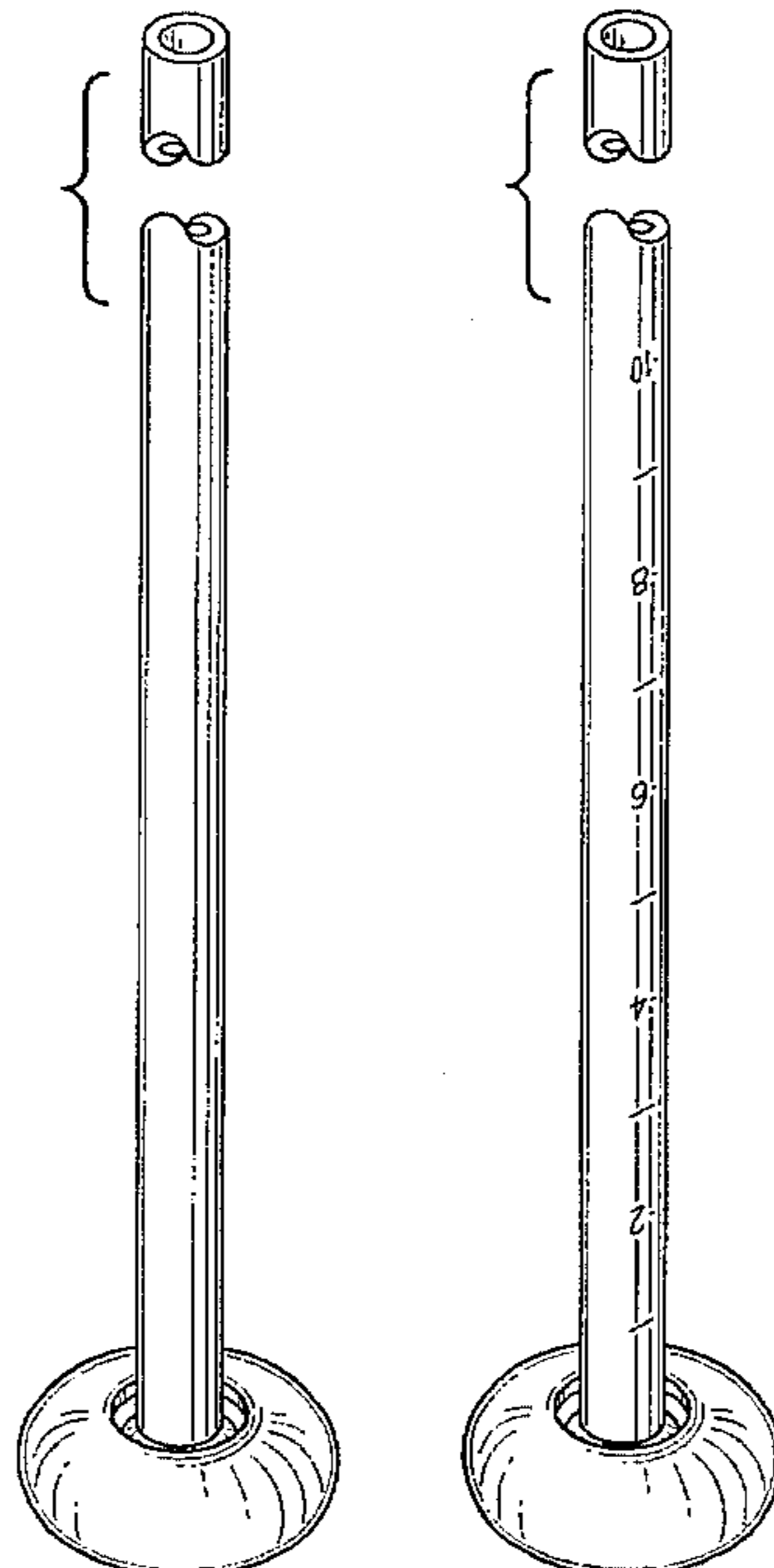

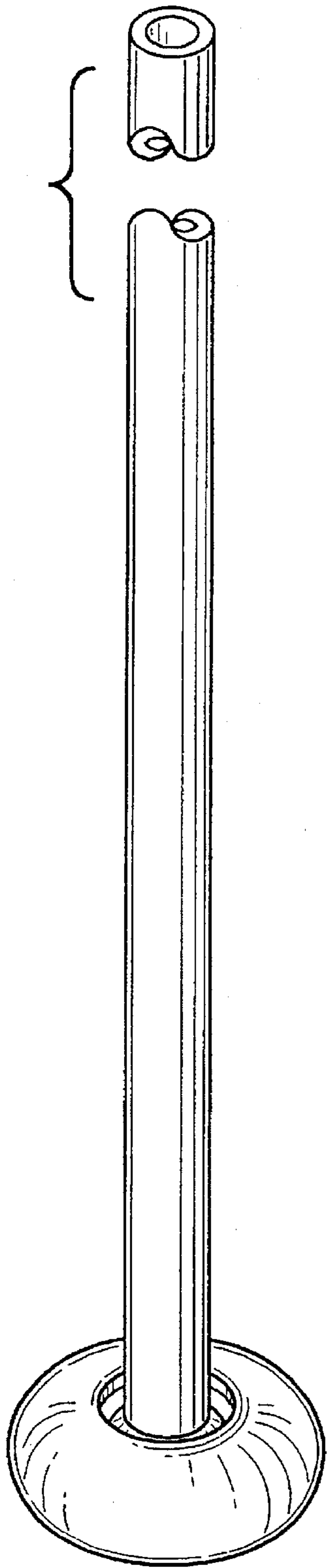

FIG-1

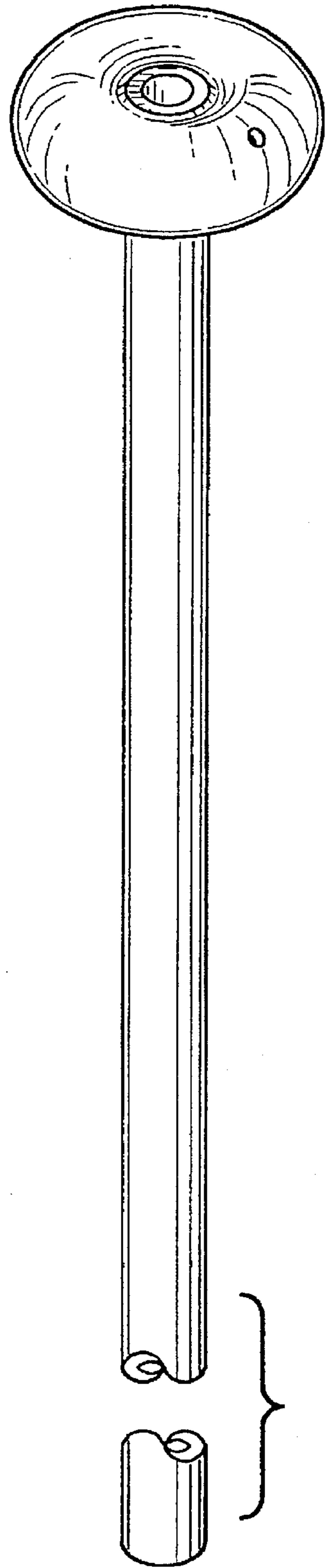

FIG-2

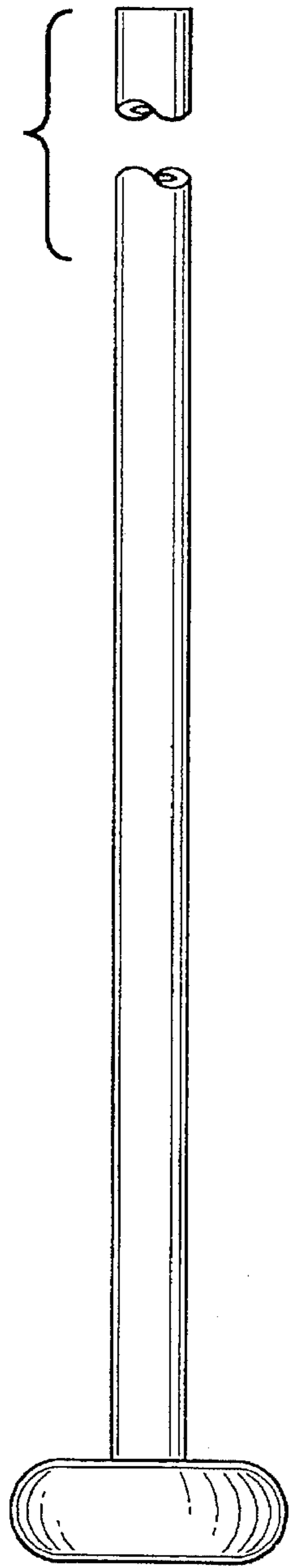

FIG-3

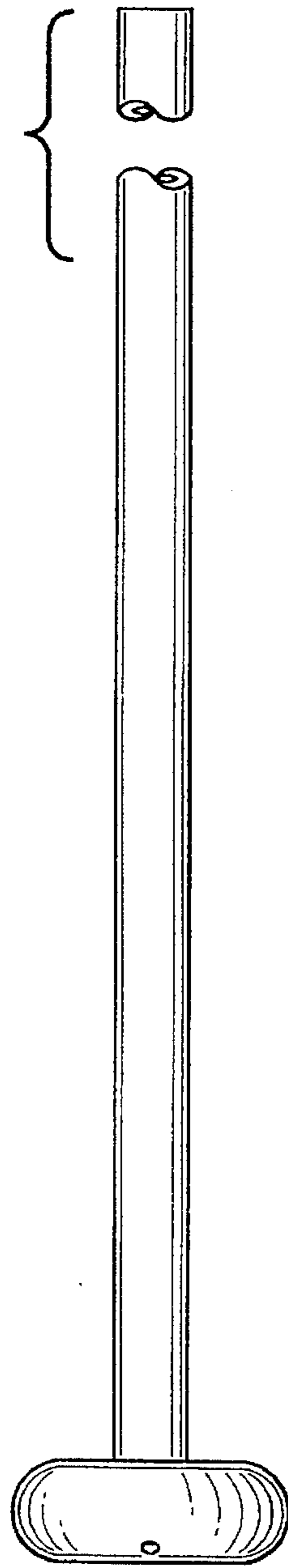

FIG-4

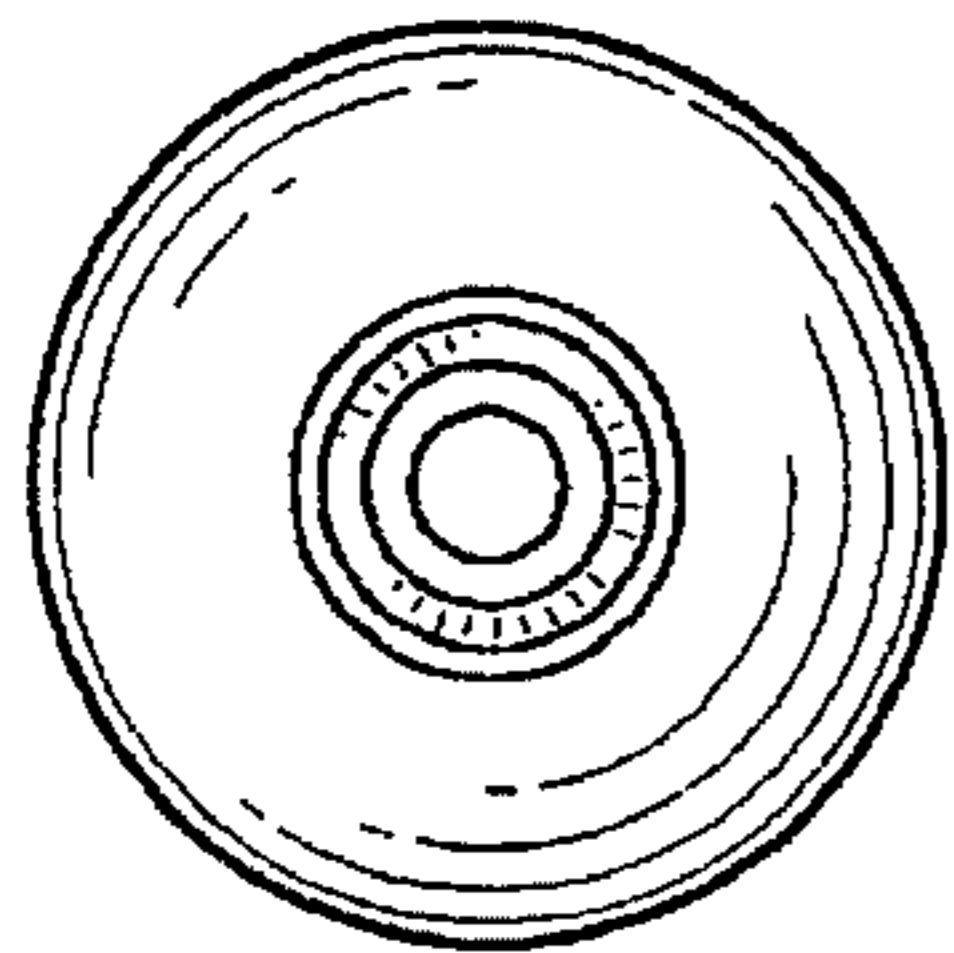

FIG-5

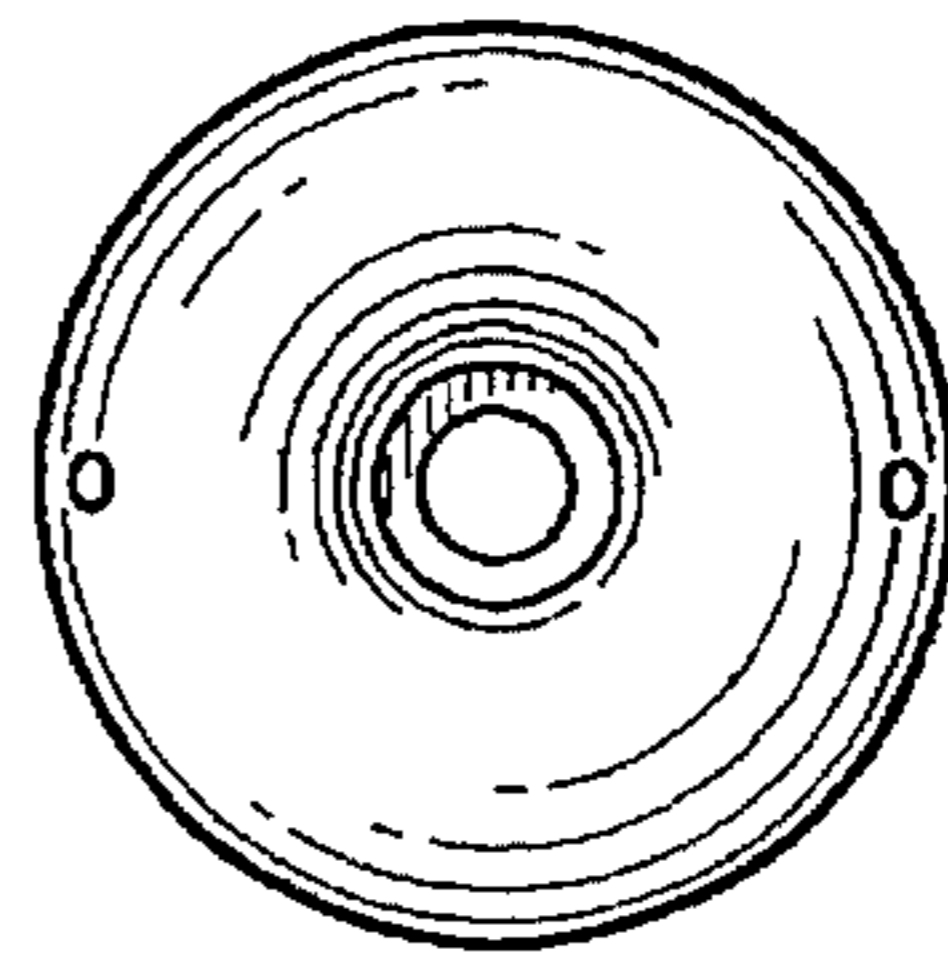

FIG-6

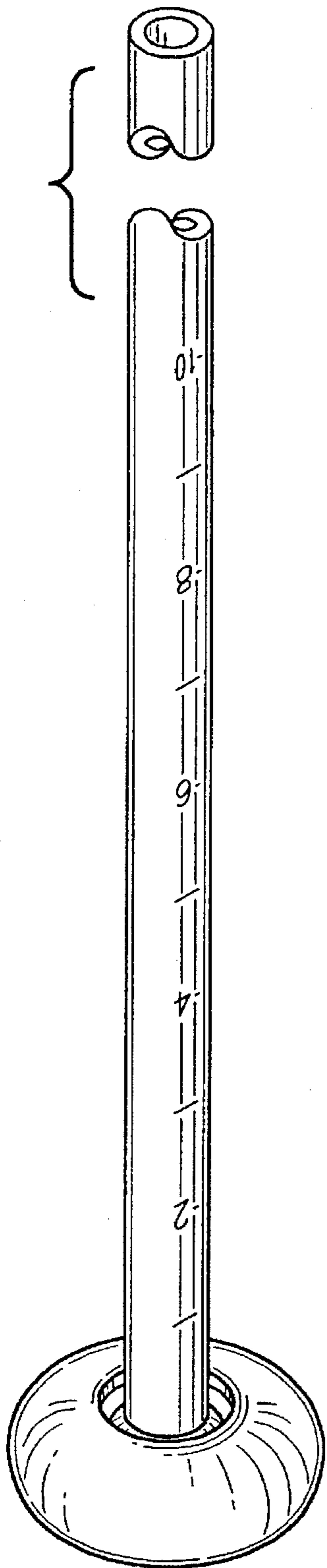

FIG-7

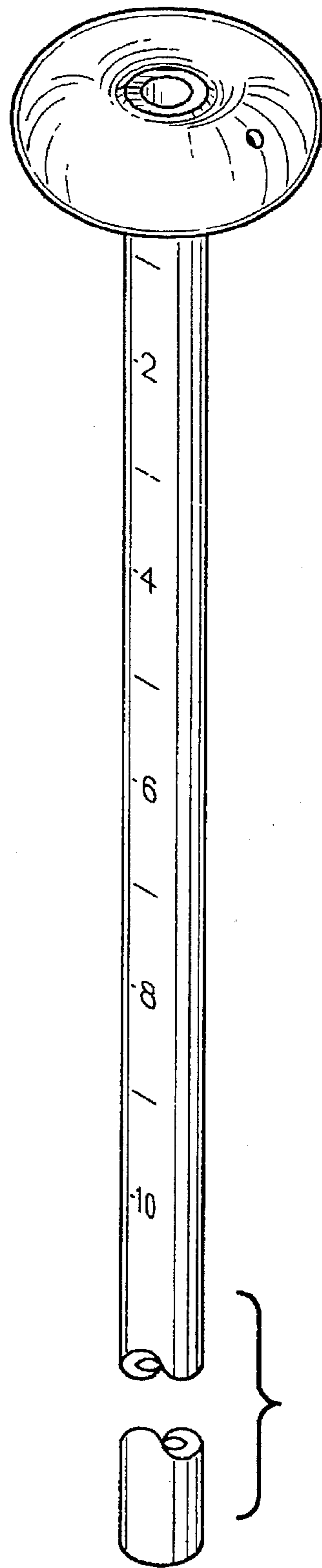

FIG-8

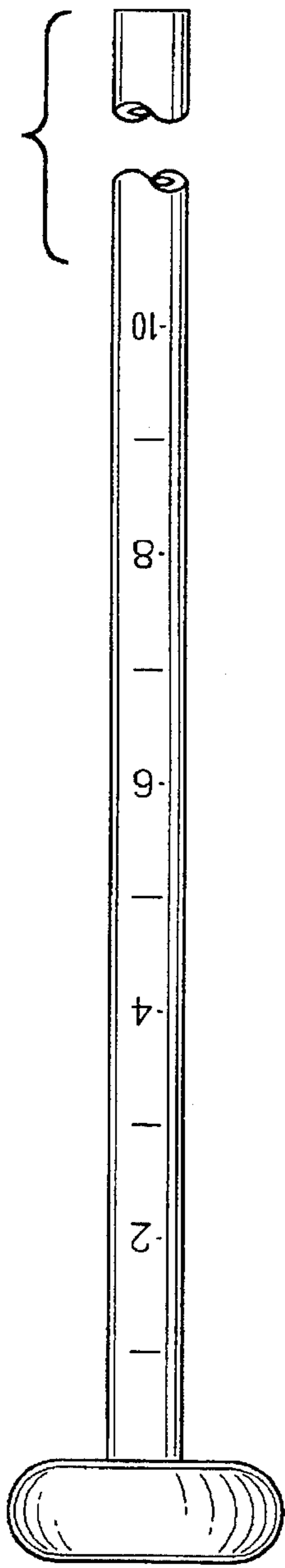

FIG-9

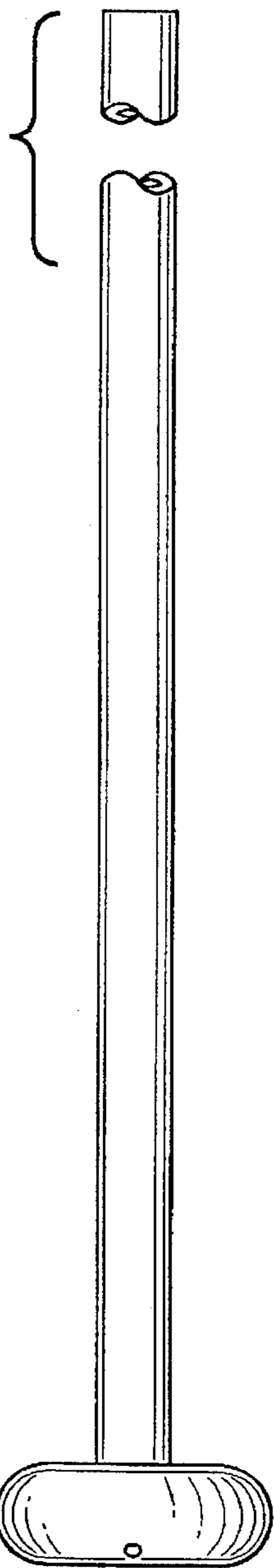

FIG-10

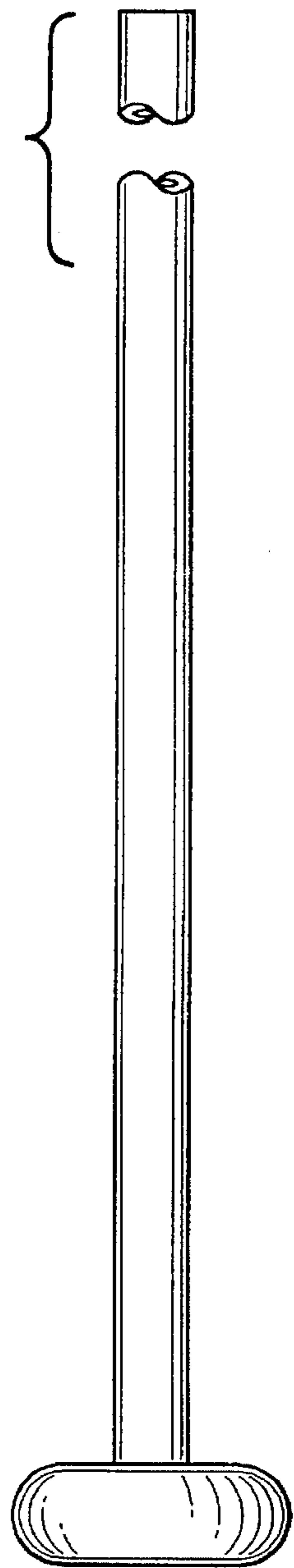

FIG-11

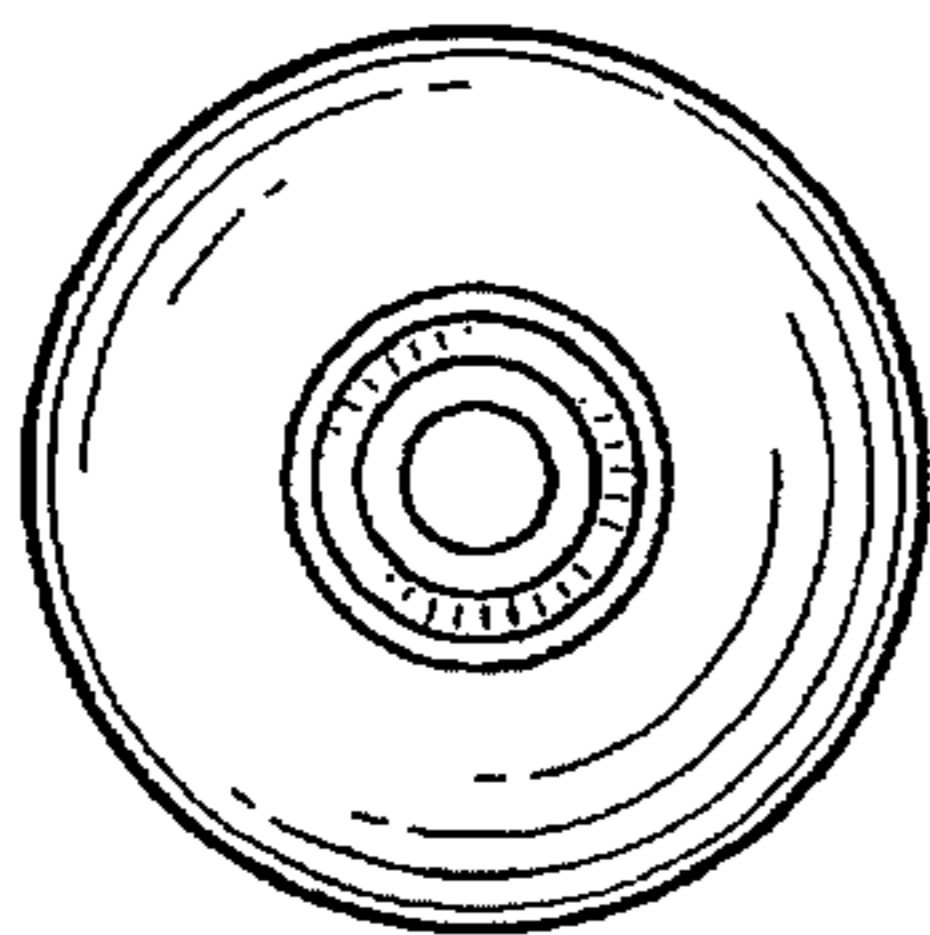

FIG-12

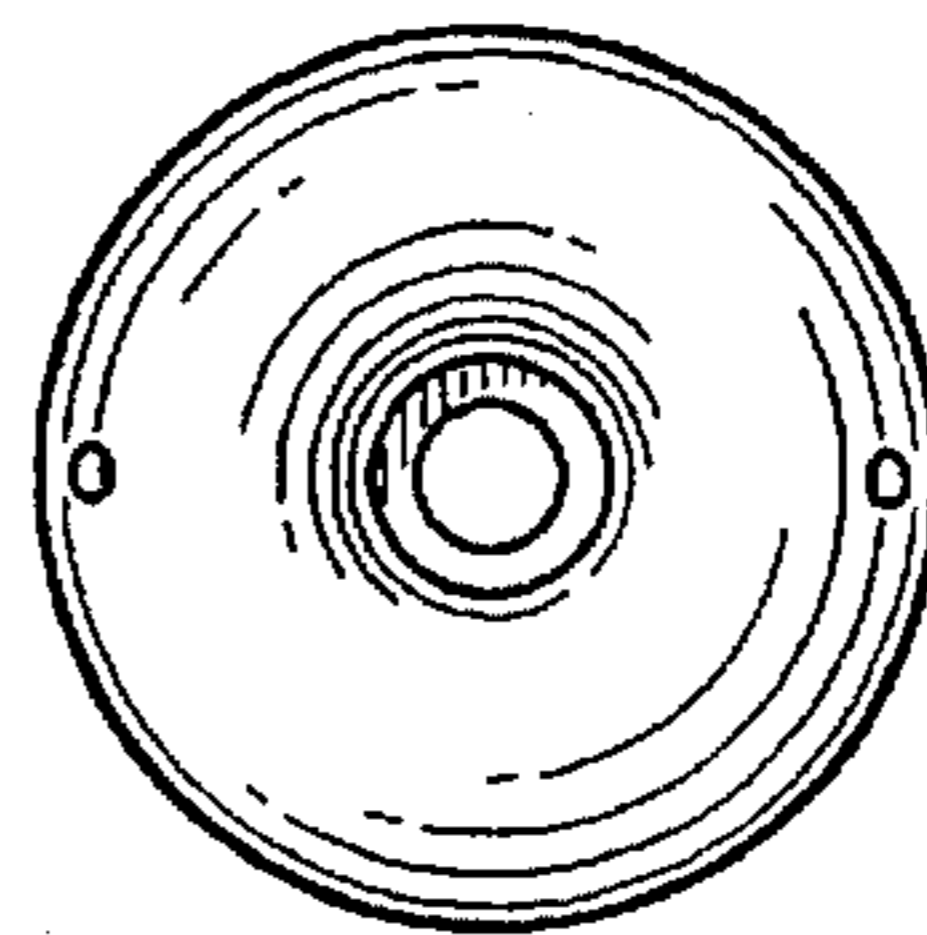

FIG-13