



US00D379819S

# United States Patent [19]

Kelley et al.

[11] Patent Number: **Des. 379,819**

[45] Date of Patent: **\*\*Jun. 10, 1997**

[54] **VEHICULAR ADAPTER FOR A PORTABLE COMMUNICATION DEVICE**

[75] Inventors: **Robert J. Kelley**, Coral Springs, Fla.;  
**Paul H. Pebbles**, Wheeling, Ill.

[73] Assignee: **Motorola, Inc.**, Schaumburg, Ill.

[\*\*] Term: **14 Years**

[21] Appl. No.: **54,064**

[22] Filed: **May 6, 1996**

[51] LOC (6) Cl. .... **14-03**

[52] U.S. Cl. .... **D14/253**

[58] **Field of Search** ..... D14/140, 240,  
D14/149, 142, 251, 253, 138; D13/107,  
108; 379/419, 420, 428, 440, 426, 446,  
454, 455, 58-61; 455/89, 90; 320/2, 5

[56] **References Cited**

**U.S. PATENT DOCUMENTS**

- D. 315,161 3/1991 Watanabe ..... D14/138 X
- D. 320,991 10/1991 Nagai et al. .... D14/138 X
- D. 345,977 4/1994 Nagele ..... D13/108 X
- D. 354,961 1/1995 Richards et al. .... D14/253
- D. 360,210 7/1995 Rudkiewicz et al. .... D14/142 X
- D. 362,004 9/1995 Nakano et al. .... D14/253
- D. 368,098 3/1996 Su ..... D14/253

- D. 368,268 3/1996 Nichols et al. .... D14/251
- D. 368,479 4/1996 Larson ..... D14/253
- D. 369,797 5/1996 Hillier et al. .... D14/149
- 5,142,573 8/1992 Umezawa ..... 455/90 X
- 5,463,688 10/1995 Wijas ..... 379/446
- 5,519,777 5/1996 Kurgan et al. .... 379/455 X

**FOREIGN PATENT DOCUMENTS**

- 0269096 6/1988 European Pat. Off. .... 379/455
- 5167657 7/1993 Japan ..... 379/455

*Primary Examiner*—Jeffrey Asch  
*Attorney, Agent, or Firm*—M. Mansour Chomeshi

[57] **CLAIM**

The ornamental design for a vehicular adapter for a portable communication device, as shown and described.

**DESCRIPTION**

FIG. 1 is a front elevational view of a vehicular adapter for a portable communication device in accordance with our new design;

FIG. 2 is a rear elevational view thereof;

FIG. 3 is a left side elevational view thereof;

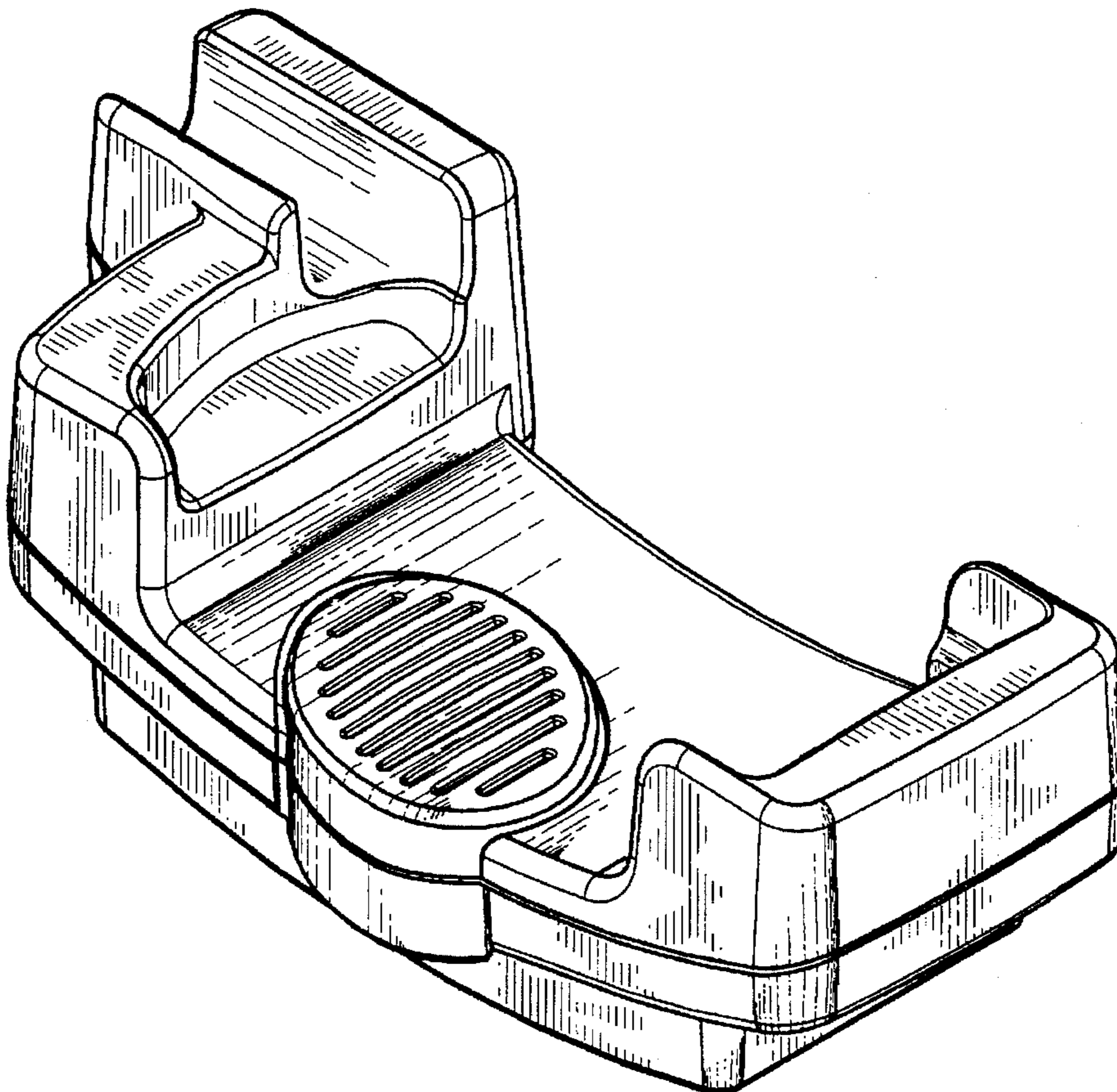
FIG. 4 is a right elevational view thereof;

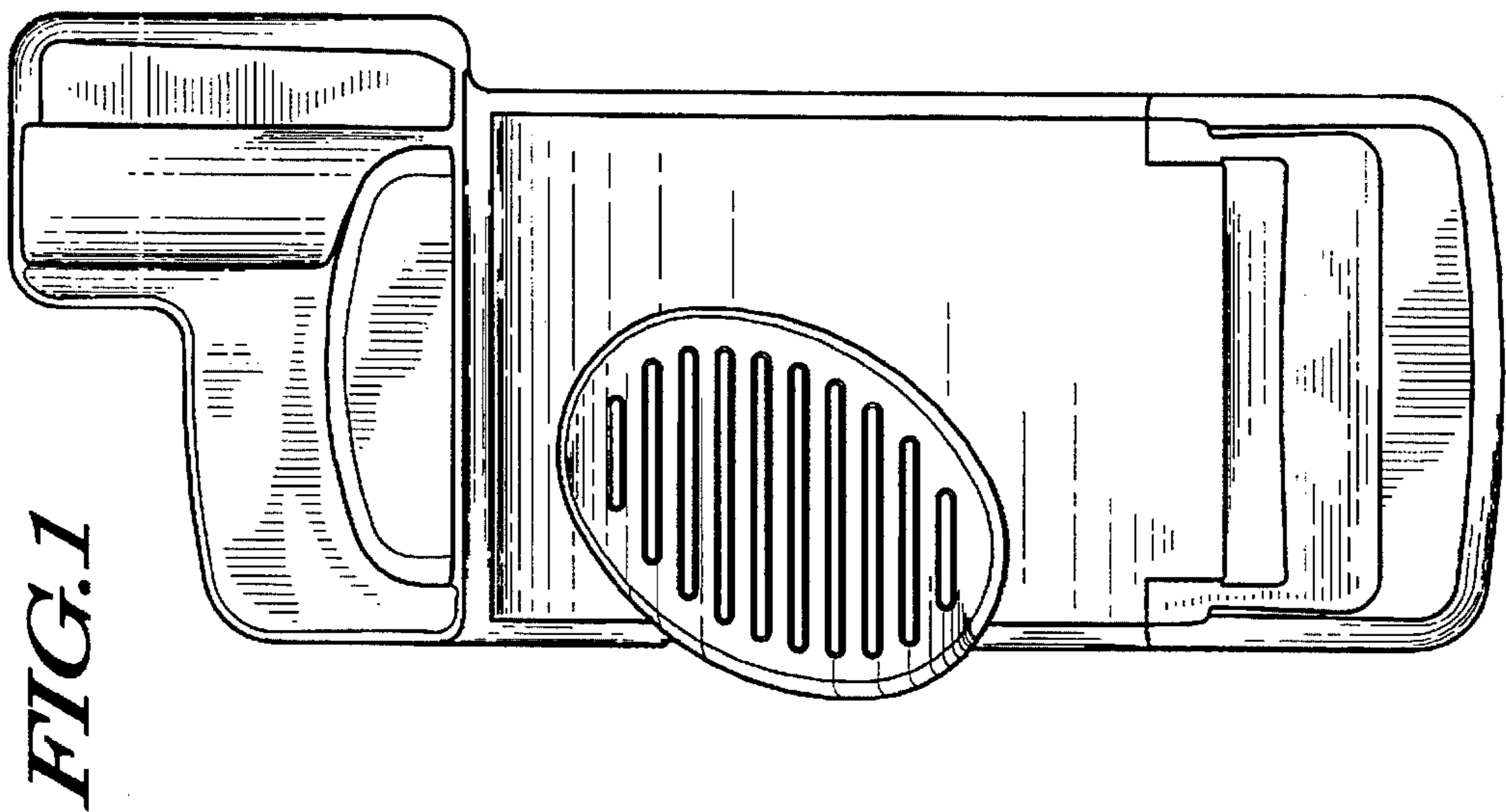
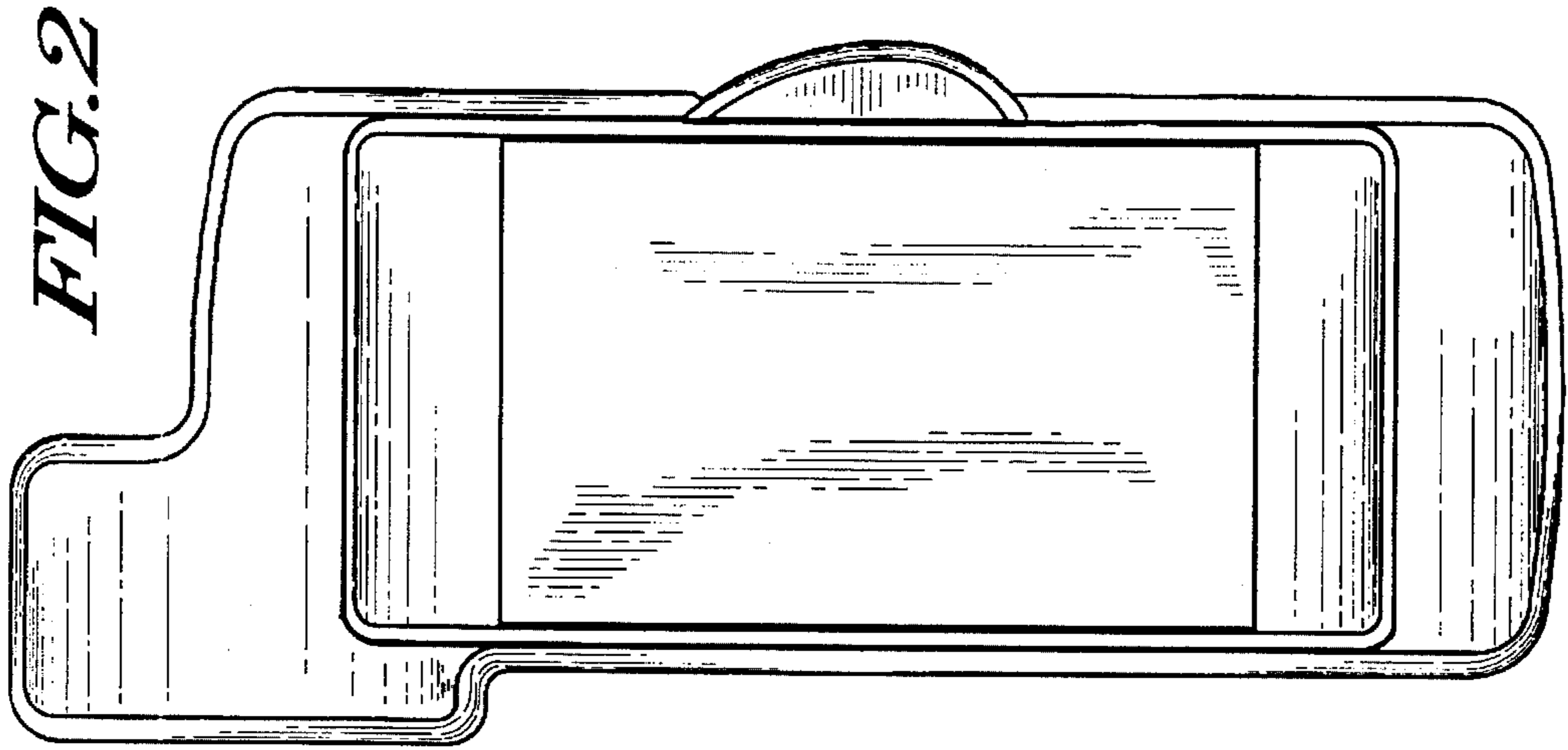
FIG. 5 is a top plan view thereof;

FIG. 6 is a bottom plan view thereof; and,

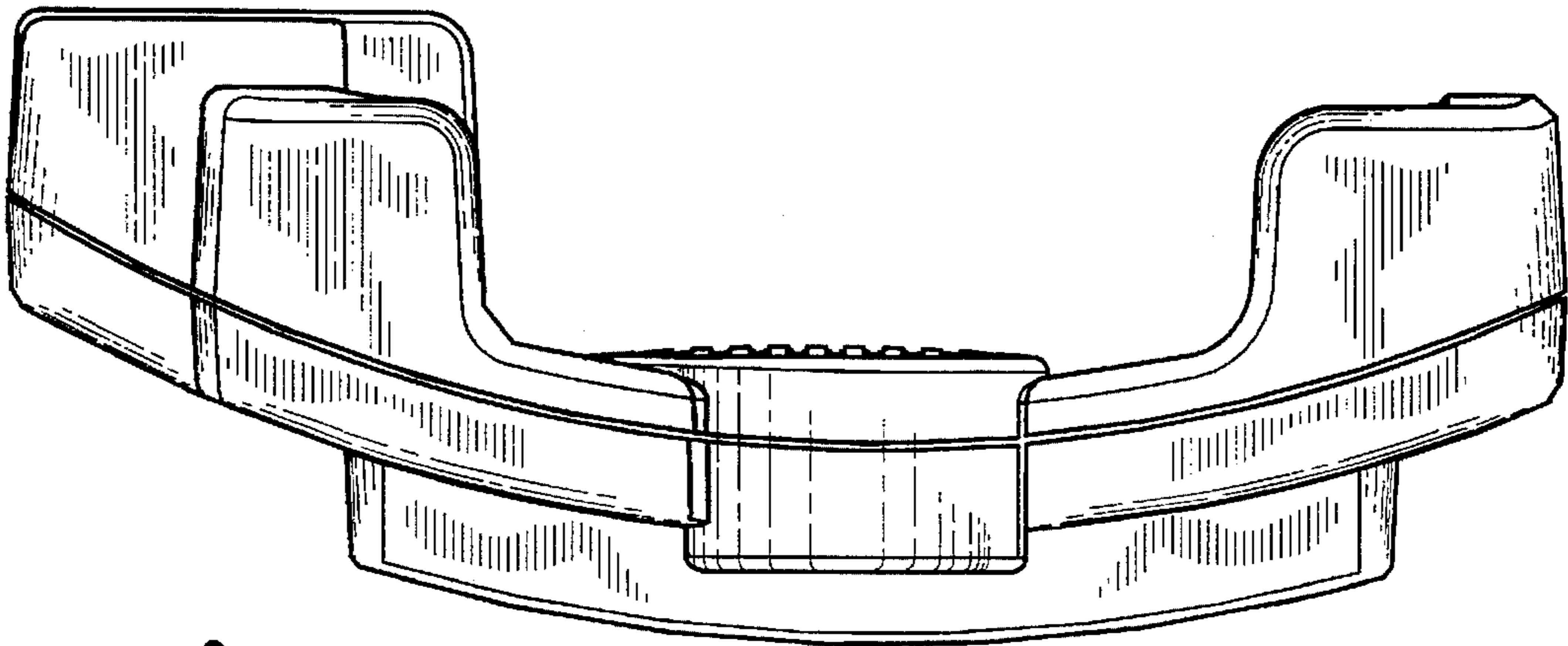
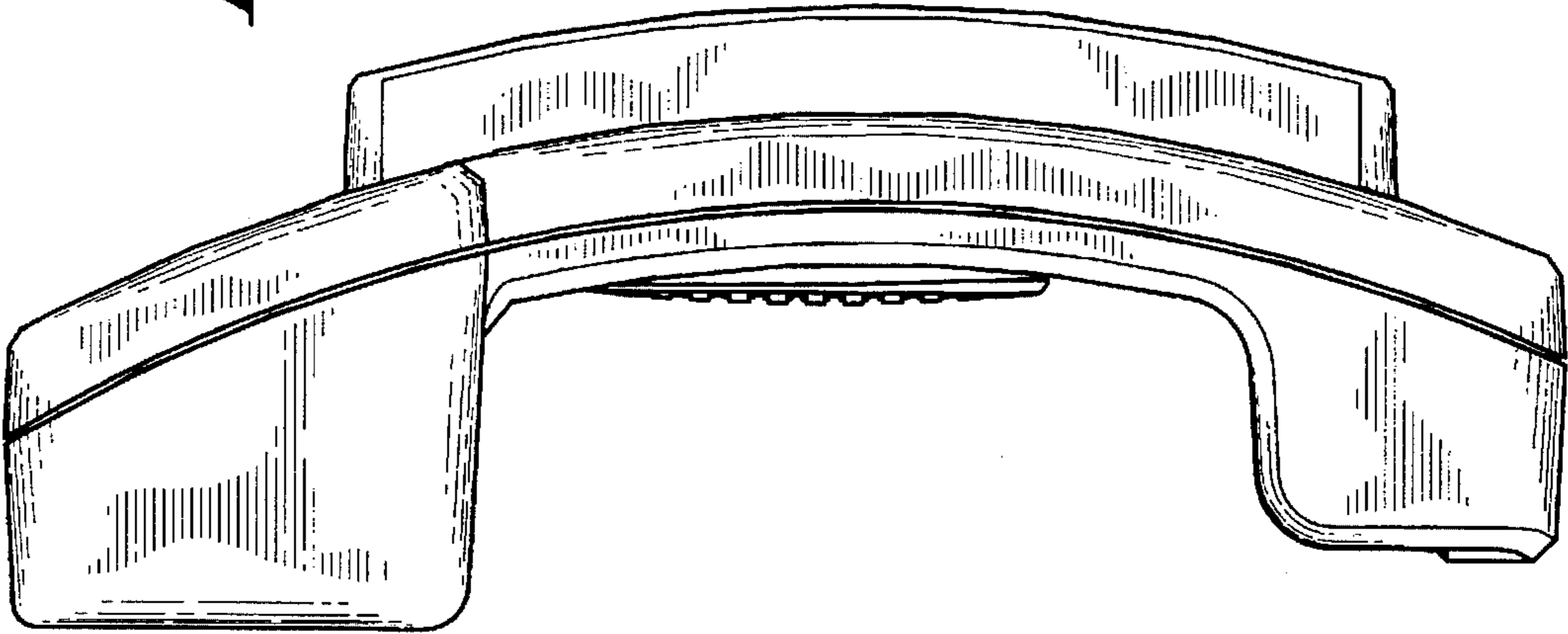
FIG. 7 is a front, left, bottom isometric view thereof.

**1 Claim, 4 Drawing Sheets**



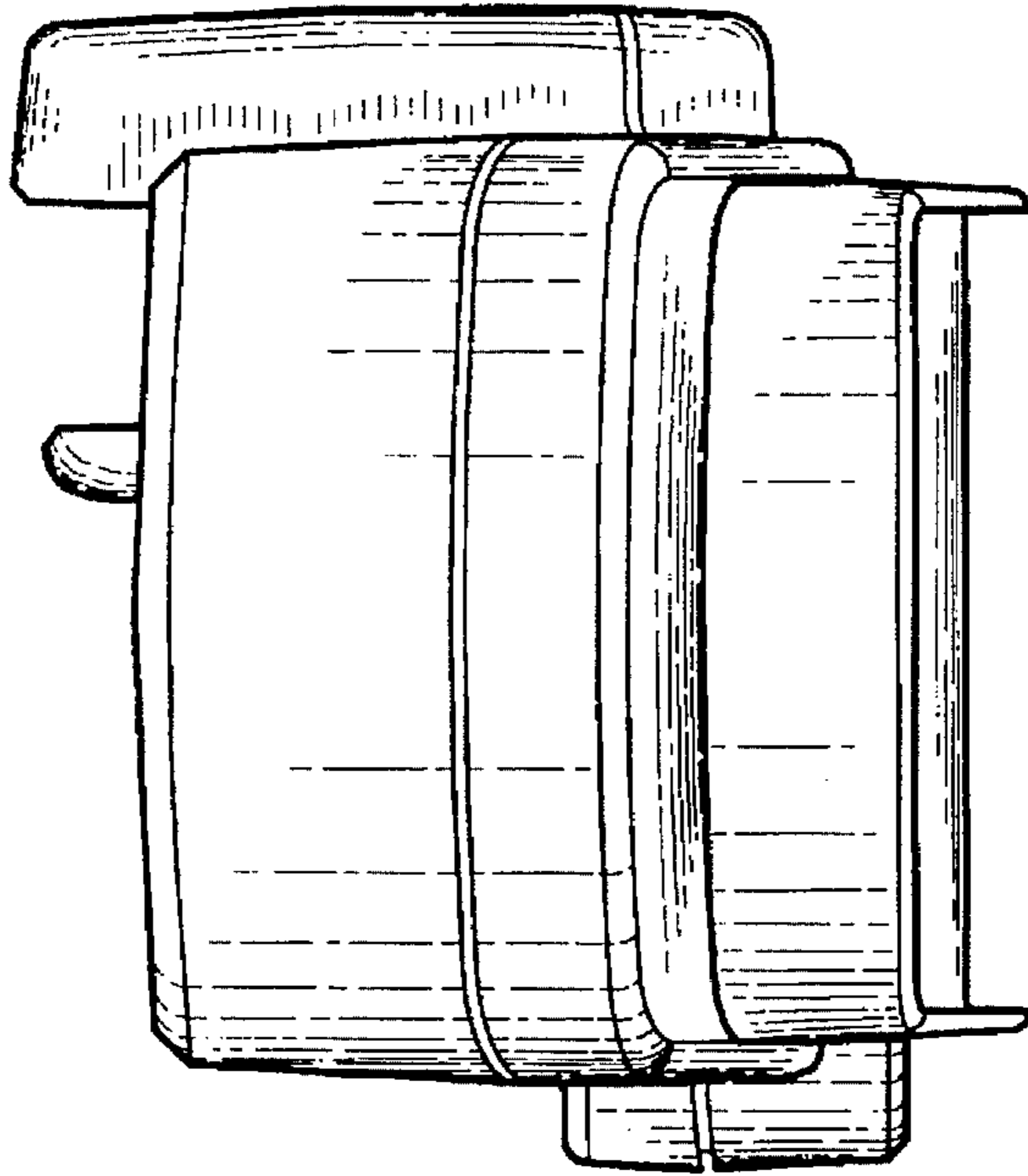


*FIG. 4*

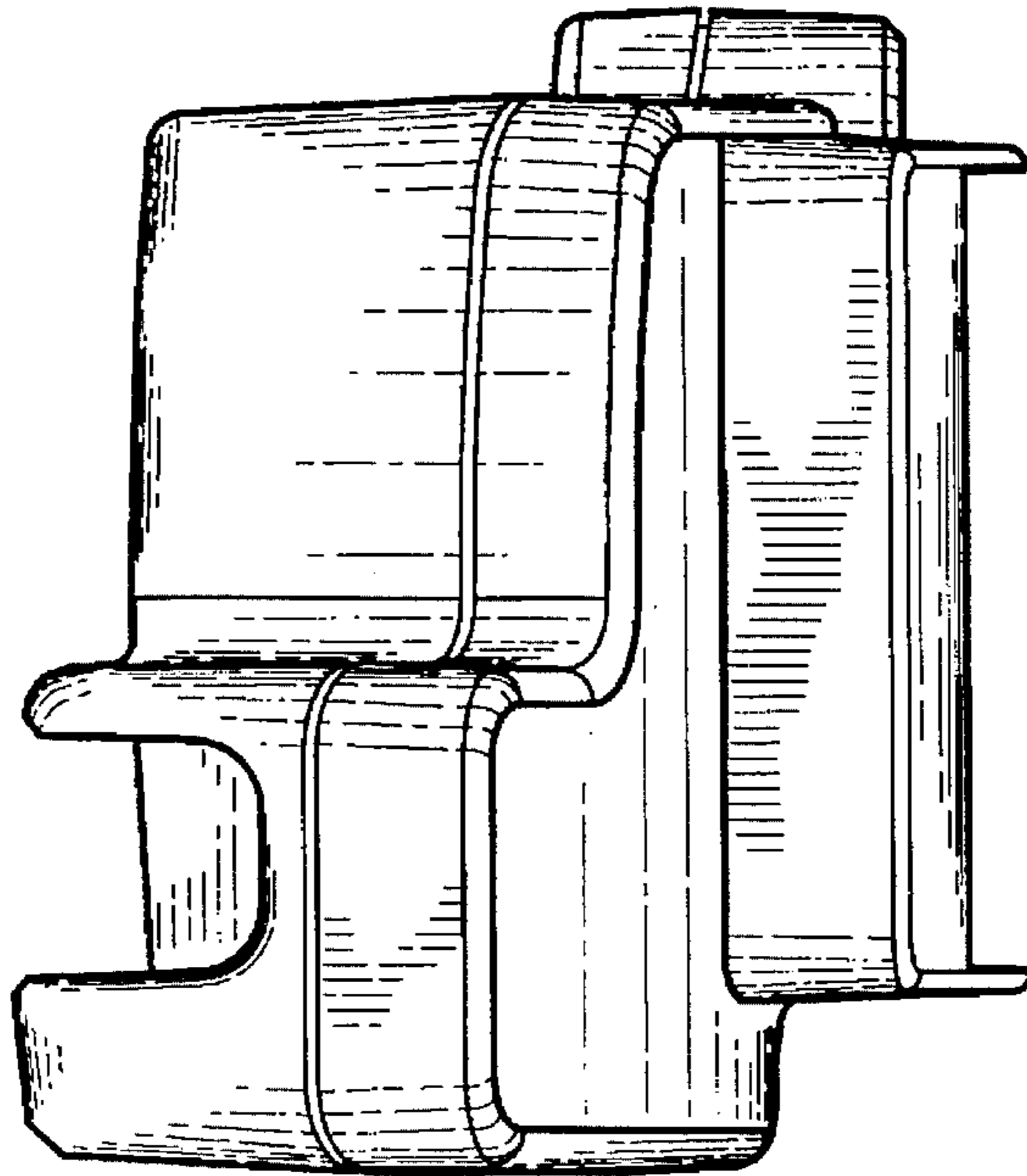


*FIG. 3*

*FIG. 6*



*FIG. 5*



*FIG. 7*

