



US00D379782S

# United States Patent [19]

[11] Patent Number: Des. 379,782

Adams

[45] Date of Patent: \*\*Jun. 10, 1997

## [54] BICYCLE TRAILER

## OTHER PUBLICATIONS

[76] Inventor: **Delbert J. Adams**, Adams Machine Works, Norman Rogers Airport (Hanger 4), Kingston, Ontario, Canada, K7M 4M1

American Bicyclist & Motorcyclist, Mar. 1992, p. 26, the 3rd Wheel bicycle trailer.

[\*\*] Term: 14 Years

*CTC Gazette* 1952, p. 867 article about Earls Court Cycle Show (Nov. 1952).

[21] Appl. No.: 16,649

"Susan, aged 6, favours a Rann trailer" short article, published in 1983.

[22] Filed: Dec. 21, 1993

"More Ideas on Family Riding" letter by Shelia Simpson, published in 1977.

### Related U.S. Application Data

*New Cyclist*, No. 8, Winter 1989/90 at p. 15 article "Three Wheels on Your Wagon" by Jim McGurn.

[63] Continuation-in-part of Ser. No. 938,450, Aug. 31, 1992, abandoned.

Trailerbikes, brochure, publication date unknown publication date prior to filing date of application.

[51] LOC (6) Cl. .... 12-11

*Primary Examiner*—Melody N. Brown

[52] U.S. Cl. .... D12/114

*Attorney, Agent, or Firm*—Thomas Adams

[58] Field of Search ..... D12/114, 101; 280/202, 204, 239, 288.1, 281.1

## [57] CLAIM

## [56] References Cited

The ornamental design for a bicycle trailer, as shown and described.

### U.S. PATENT DOCUMENTS

### DESCRIPTION

D. 273,287	4/1984	Evans	D12/107
D. 283,883	5/1986	Chen et al.	D12/107
3,653,679	4/1972	Howard	280/204
3,787,065	1/1974	Grimm	280/204
3,934,666	1/1976	Ellington	180/11
4,756,541	7/1988	Albitre	280/204
4,928,985	5/1990	Nowlin	280/204
5,067,738	11/1991	O'Connor	280/204
5,076,600	12/1991	Fake	280/204

FIG. 1 is a front and side perspective view of a bicycle trailer showing my new design;

FIG. 2 is a side elevation view showing the opposite side of the bicycle trailer of FIG. 1, the broken lines being for illustrative purposes only and representing a bicycle which does not form part of the design; and,

FIG. 3 is a side elevation view showing the opposite side of the bicycle trailer.

### FOREIGN PATENT DOCUMENTS

1235435	4/1988	Canada	.
2053546	4/1993	Canada	280/239
968629	12/1950	France	.
811077	8/1951	Germany	.
185820	11/1936	Switzerland	.

The characteristic feature of the design resides in the two curved tubes which are attached at their respective rearward ends to the seat post and curve upwards and forwards, converging towards the forward end of the trailer.

1 Claim, 3 Drawing Sheets

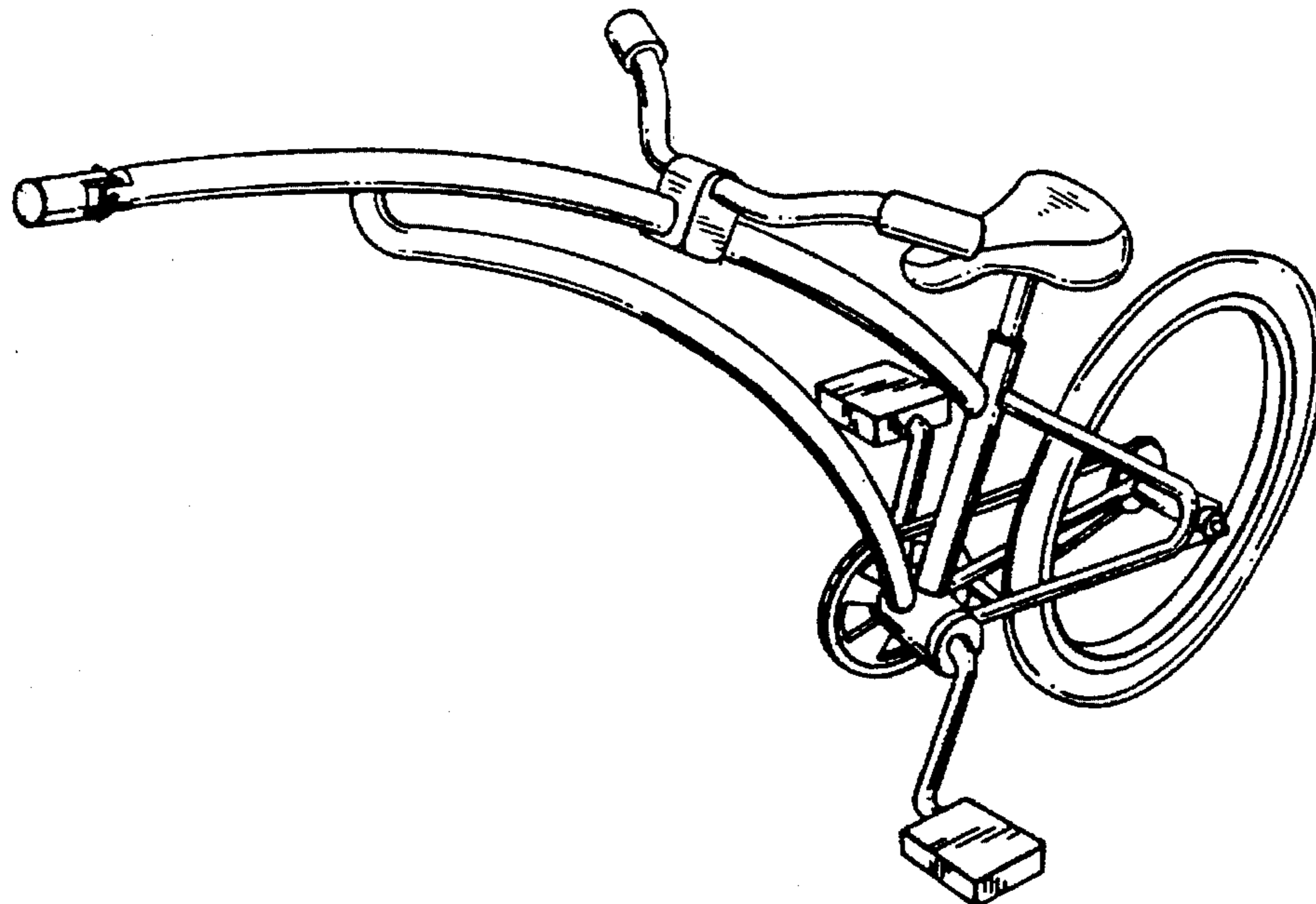

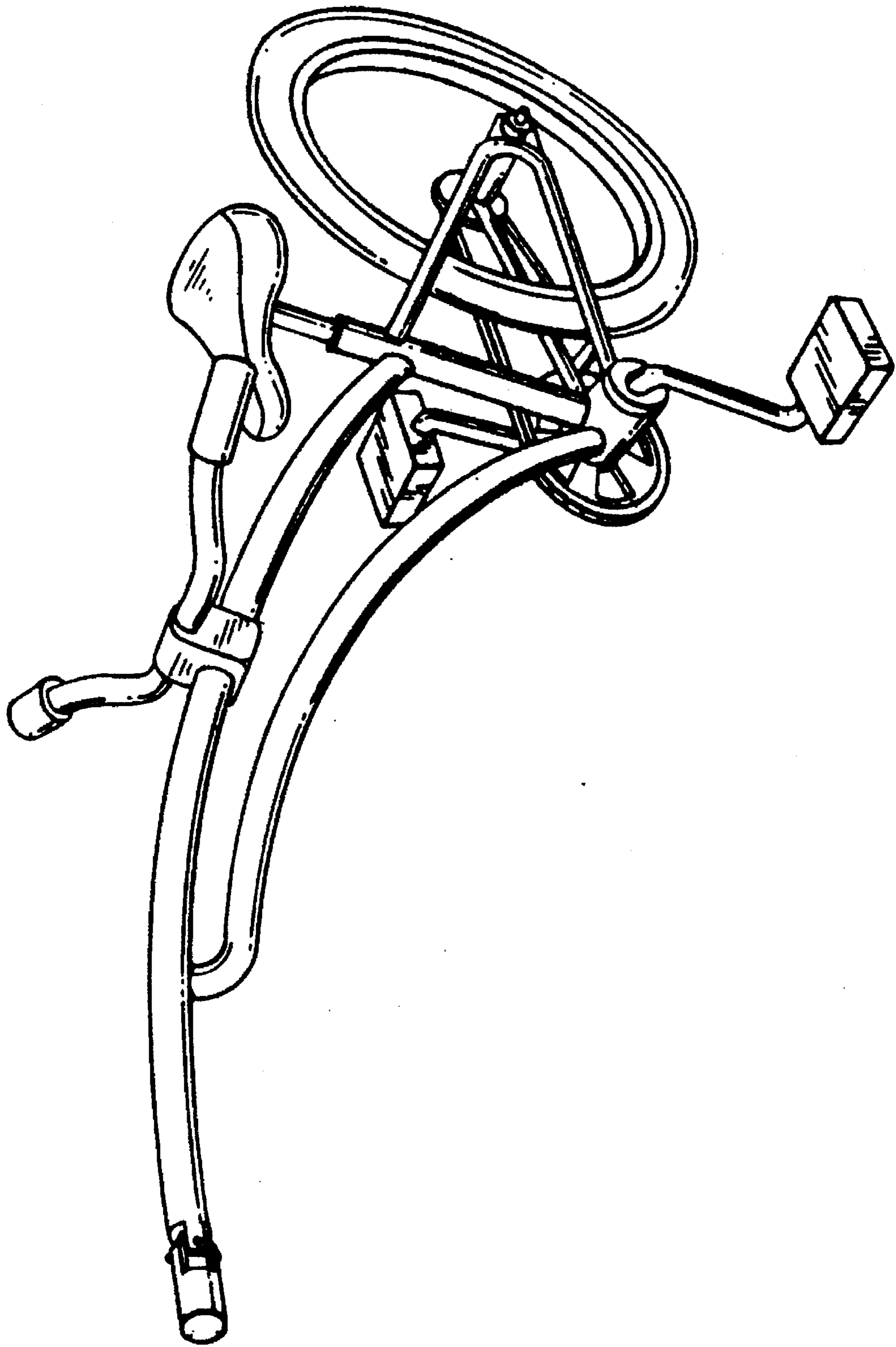

FIG. 1

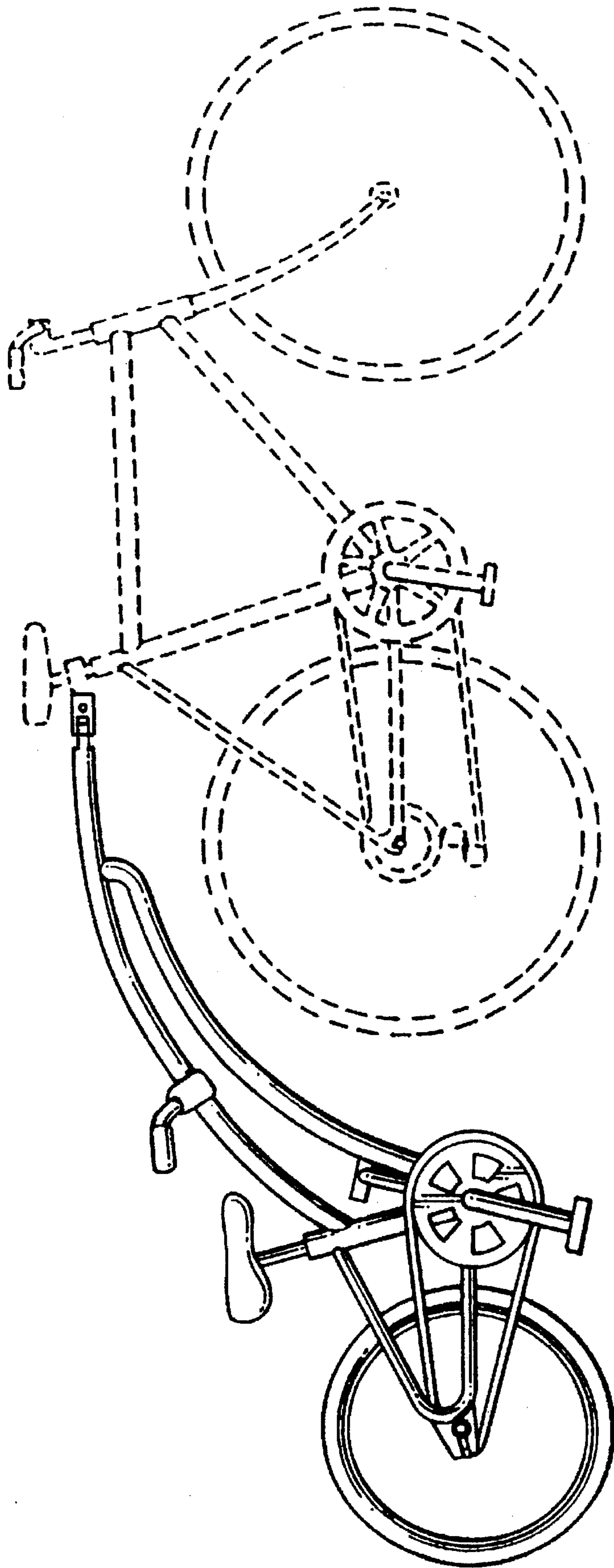

FIG. 2

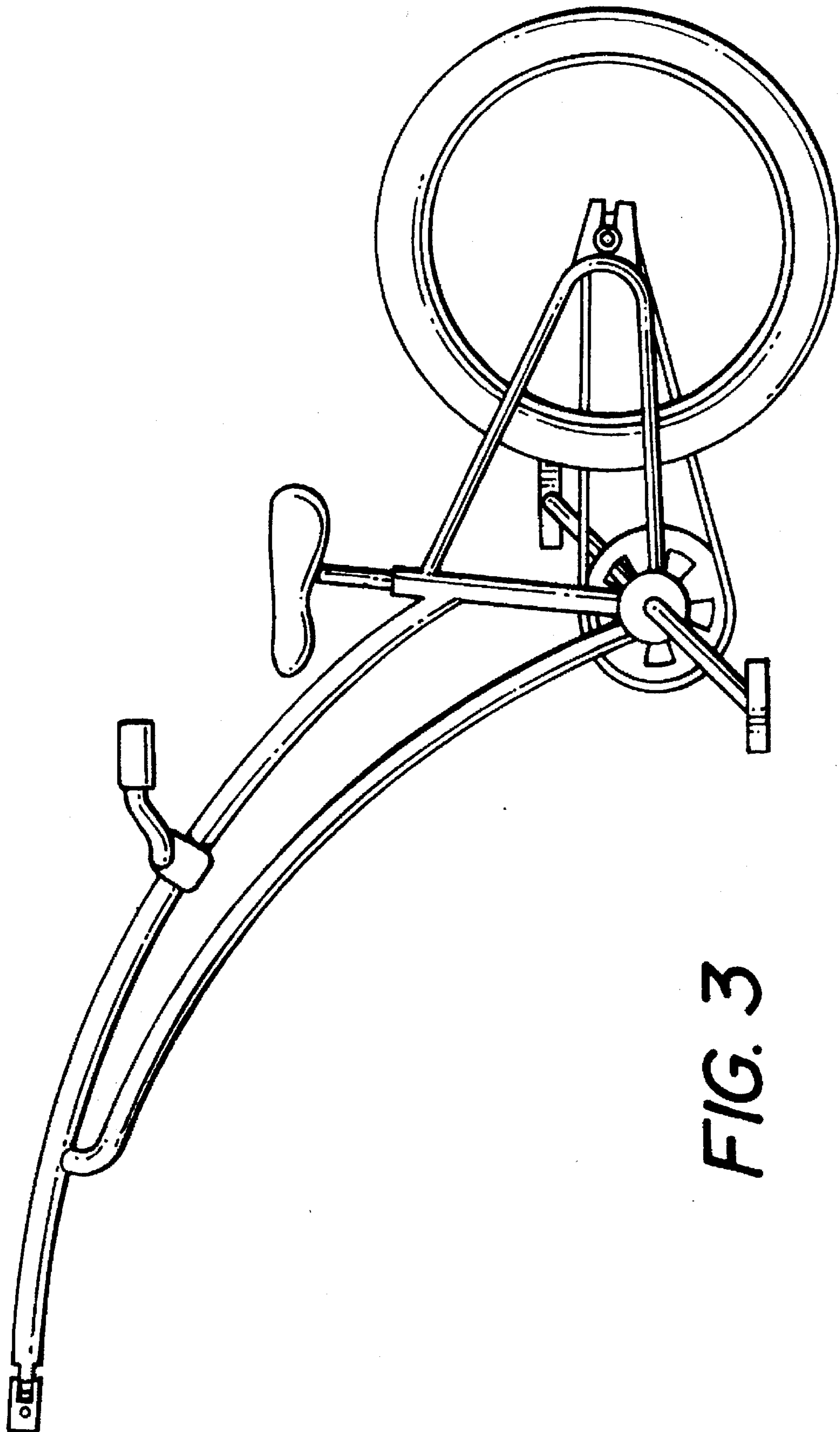

FIG. 3