



US00D379777S

United States Patent [19]

Segan et al.

[11] Patent Number: Des. 379,777

[45] Date of Patent: **Jun. 10, 1997

[54] HOLIDAY DISPLAY WITH MINIATURE FERRIS WHEELS

[75] Inventors: **Marc H. Segan**, New York; **Gary Strauss**, Mamaroneck; **Lori Shields**, East Northport, all of N.Y.

[73] Assignee: **M.H. Segan Limited Partnership**, Great Barrington, Mass.

[**] Term: 14 Years

[21] Appl. No.: 30,656

[22] Filed: Nov. 4, 1994

[51] LOC (6) Cl. 11-05

[52] U.S. Cl. D11/121; D11/125; D11/130; D11/157; D21/248

[58] Field of Search D11/117, 121, D11/125, 130, 132, 157; D21/248; 362/249, 252, 806, 808; 40/411, 414, 421, 423; 472/45, 46

[56] References Cited

U.S. PATENT DOCUMENTS

D. 211,035	5/1968	Spengler	D21/248	X
D. 225,880	1/1973	Spiegel	D21/248	X
D. 283,522	4/1986	Munson et al.	D21/59	X
D. 347,802	6/1994	Kielbasa	D11/121	
3,820,265	6/1974	Leonard	40/411	
3,858,339	1/1975	Short	40/411	X

Primary Examiner—Dominic Simone

Attorney, Agent, or Firm—Cohen, Pontani, Lieberman, Pavane

[57] CLAIM

The ornamental design for a holiday display with miniature ferris wheels, as shown and described.

DESCRIPTION

FIG. 1 is a perspective view of a holiday display with miniature ferris wheels showing our new design;

FIG. 2 is a front elevational view of the base module, shown separately for clarity of illustration;

FIG. 3 is a left side elevational view of FIG. 2;

FIG. 4 is a right side elevational view of FIG. 2;

FIG. 5 is a top plan view of FIG. 2;

FIG. 6 is a bottom plan view of FIG. 2;

FIG. 7 is a rear elevational view of FIG. 2;

FIG. 8 is a top plan view of the first ferris wheel, shown separately for clarity of illustration;

FIG. 9 is a front elevational view of FIG. 8;

FIG. 10 is a right side elevational view of FIG. 8;

FIG. 11 is a left side elevational view of FIG. 8;

FIG. 12 is a rear elevational view of FIG. 8;

FIG. 13 is a bottom plan view of FIG. 8;

FIG. 14 is a top plan view of the second ferris wheel, shown separately for clarity of illustration;

FIG. 15 is a front elevational view of FIG. 14;

FIG. 16 is a right side elevational view of FIG. 14;

FIG. 17 is a left side elevational view of FIG. 14;

FIG. 18 is a rear elevational view of FIG. 14;

FIG. 19 is a bottom plan view of FIG. 14;

FIG. 20 is a top plan view of the third ferris wheel, shown separately for clarity of illustration;

FIG. 21 is a front elevational view of FIG. 20;

FIG. 22 is a right side elevational view of FIG. 20;

FIG. 23 is a left side elevational view of FIG. 20;

FIG. 24 is a rear elevational view of FIG. 20; and,

FIG. 25 is a bottom plan view of FIG. 20.

1 Claim, 11 Drawing Sheets

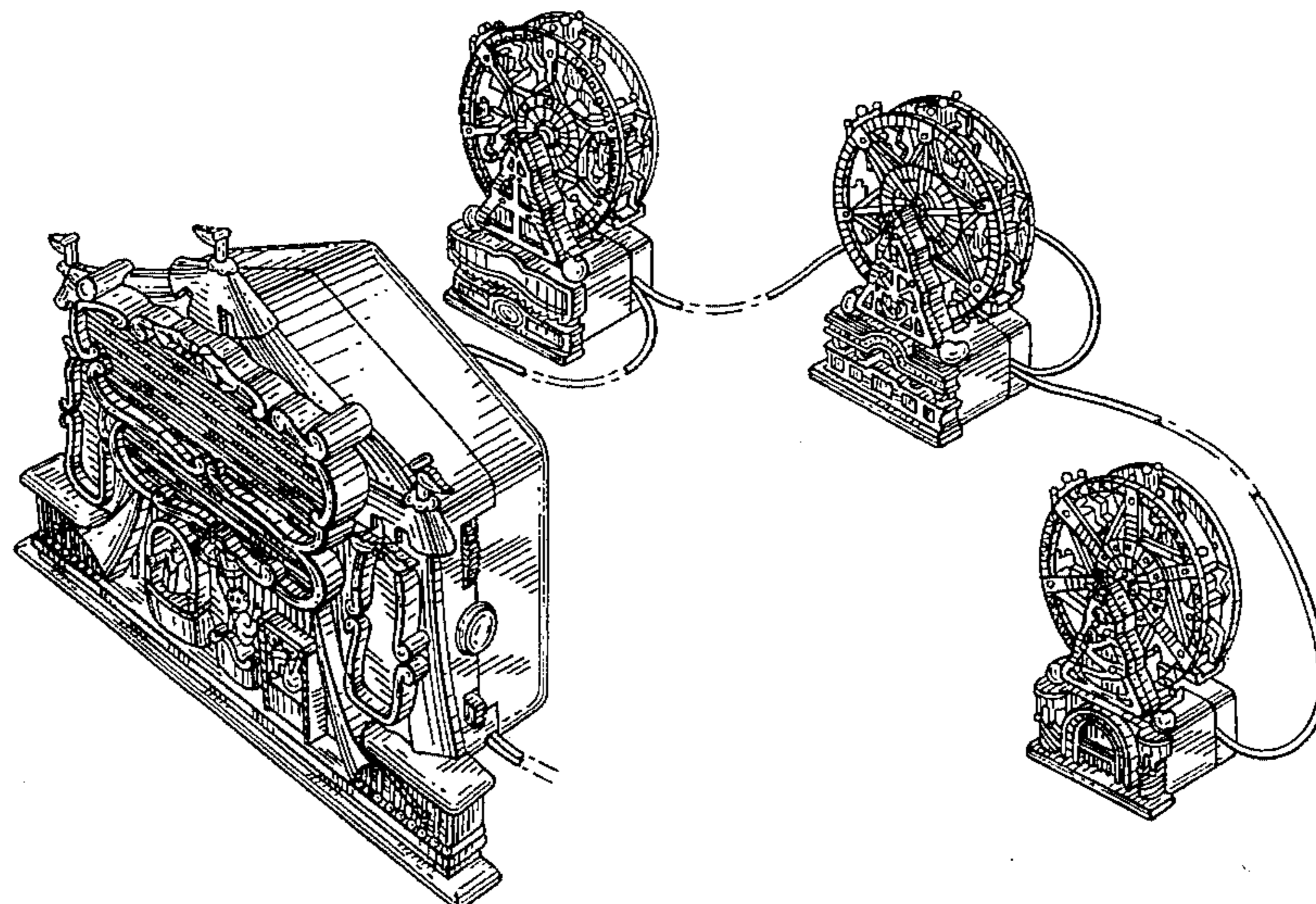

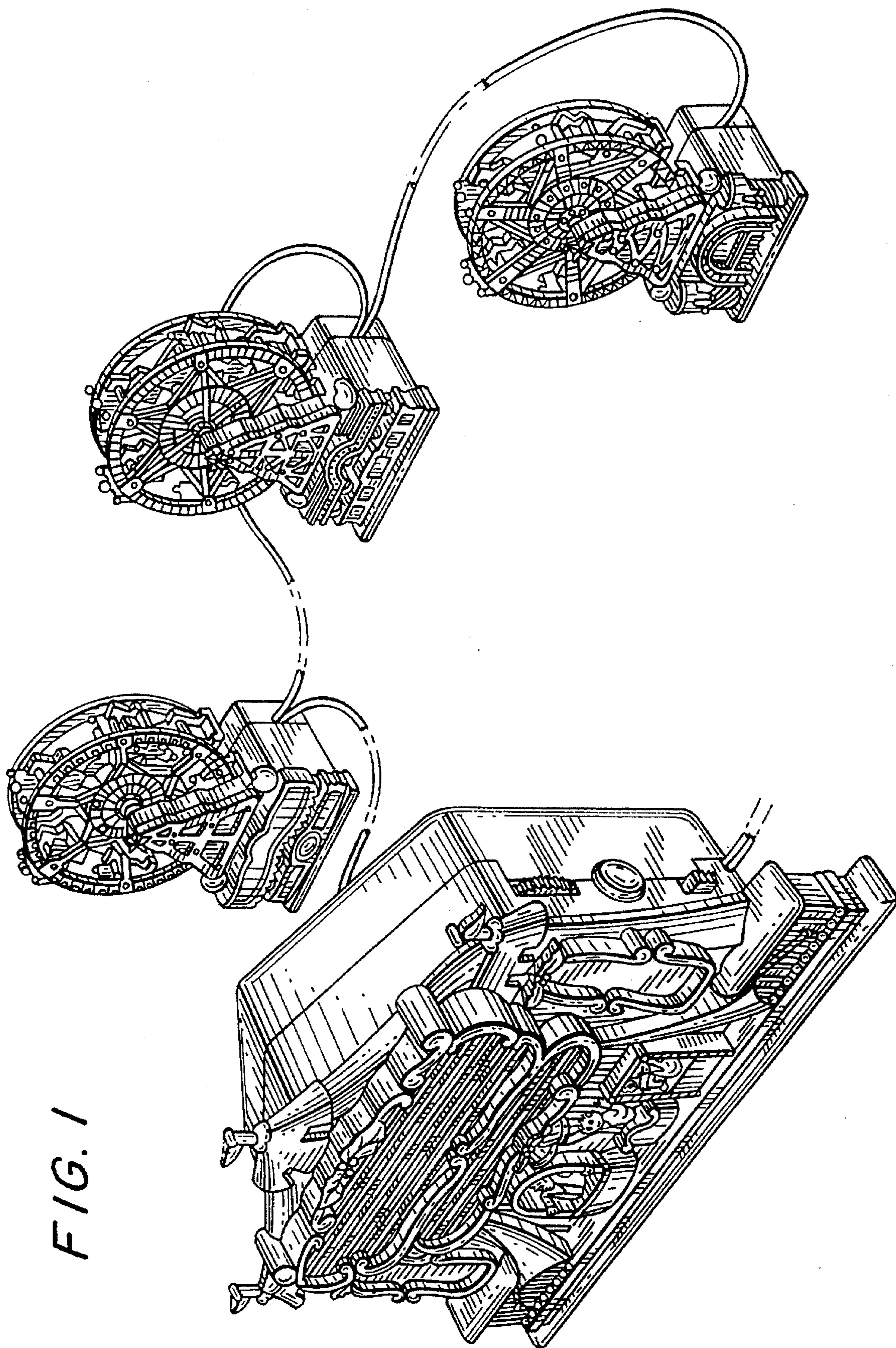

FIG. 1

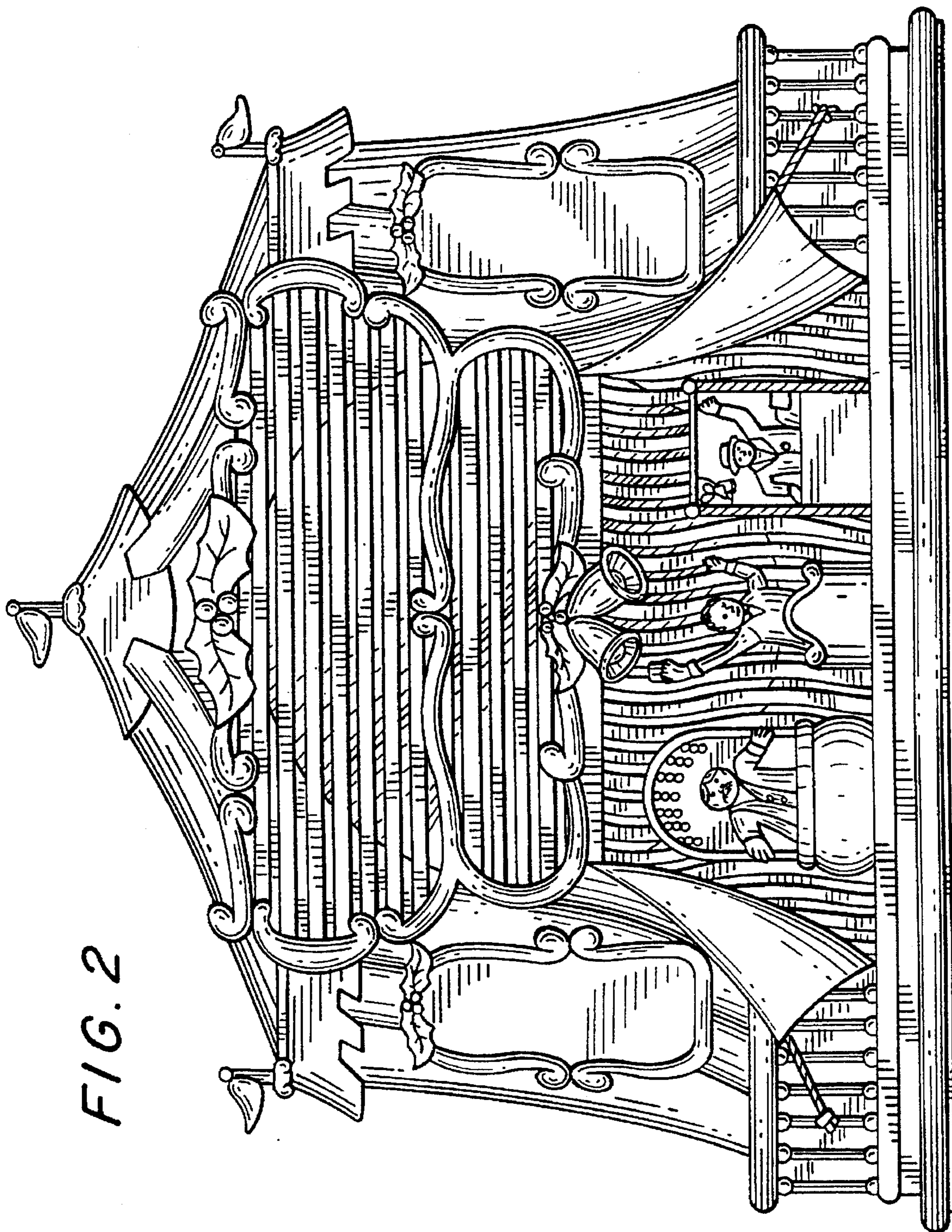

FIG. 2

FIG. 4

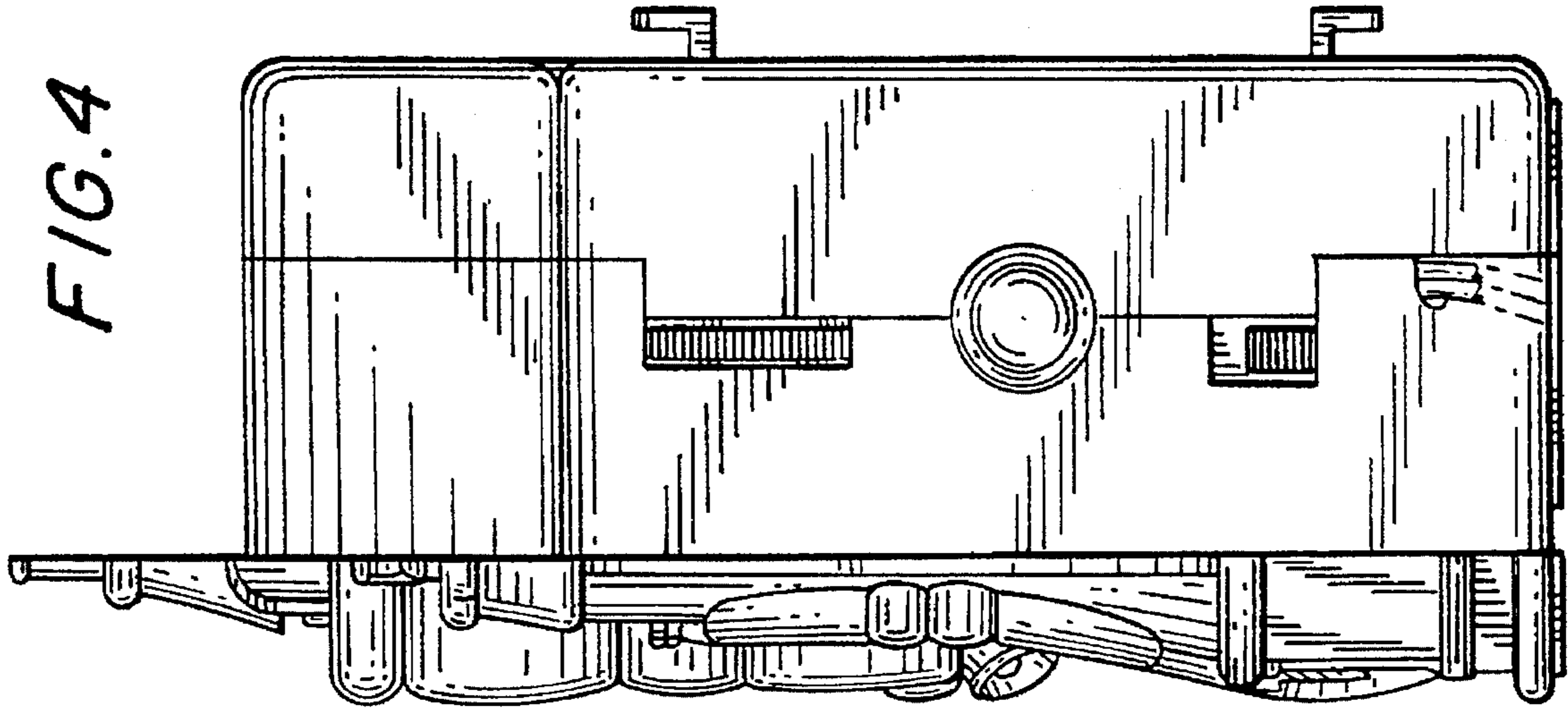
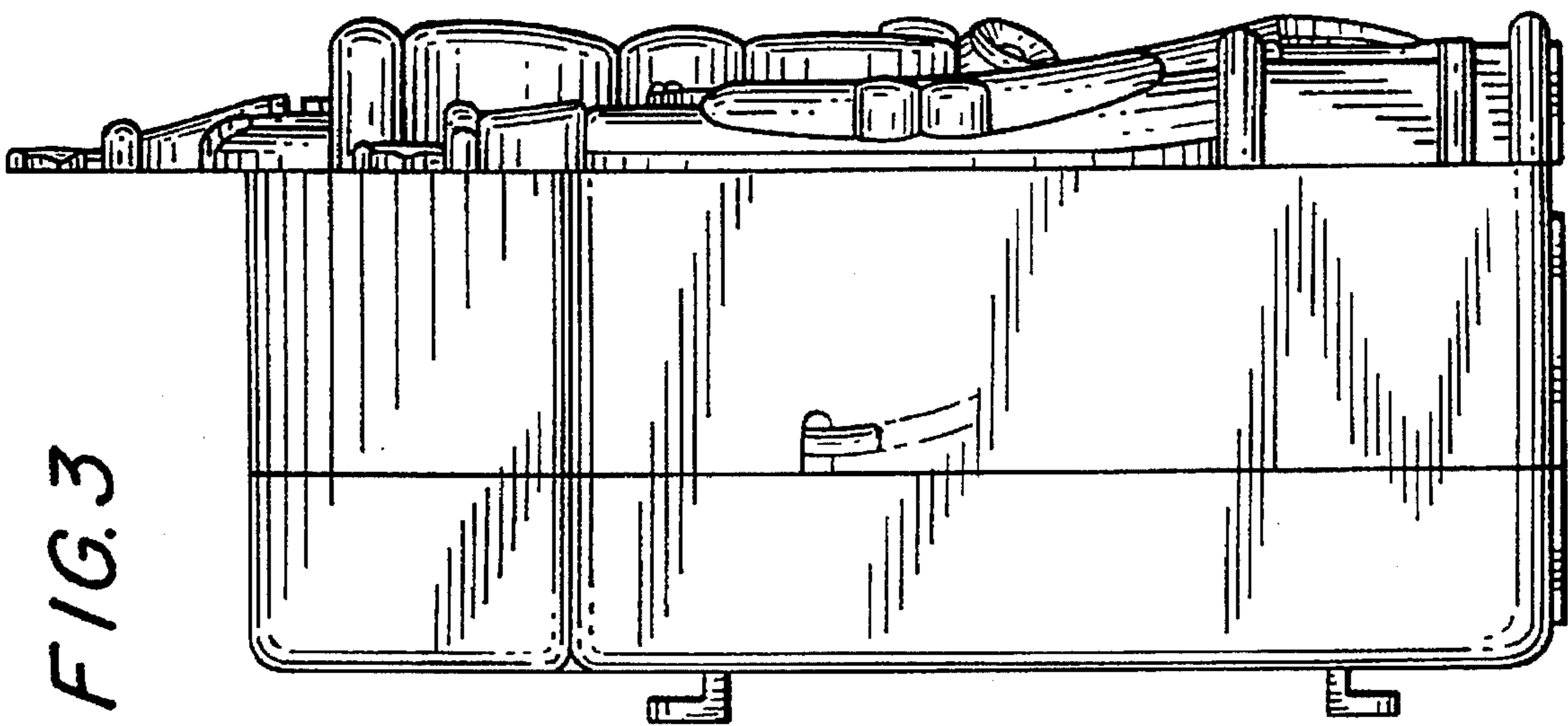

FIG. 3



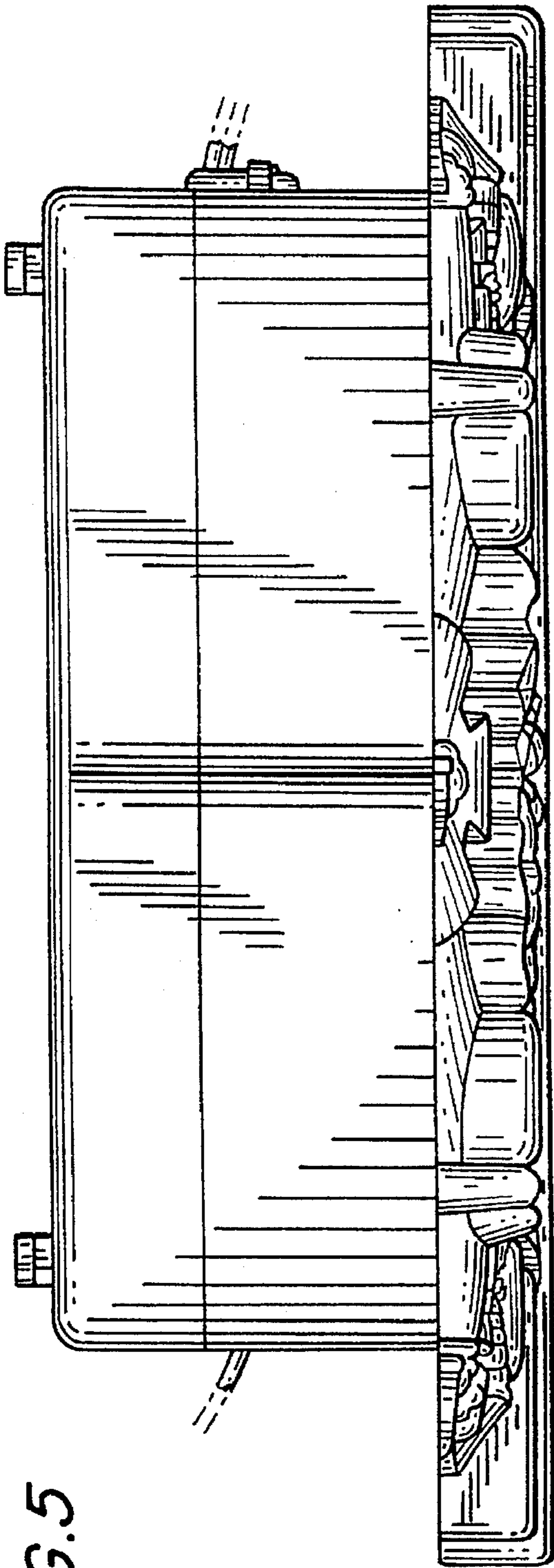

FIG. 5

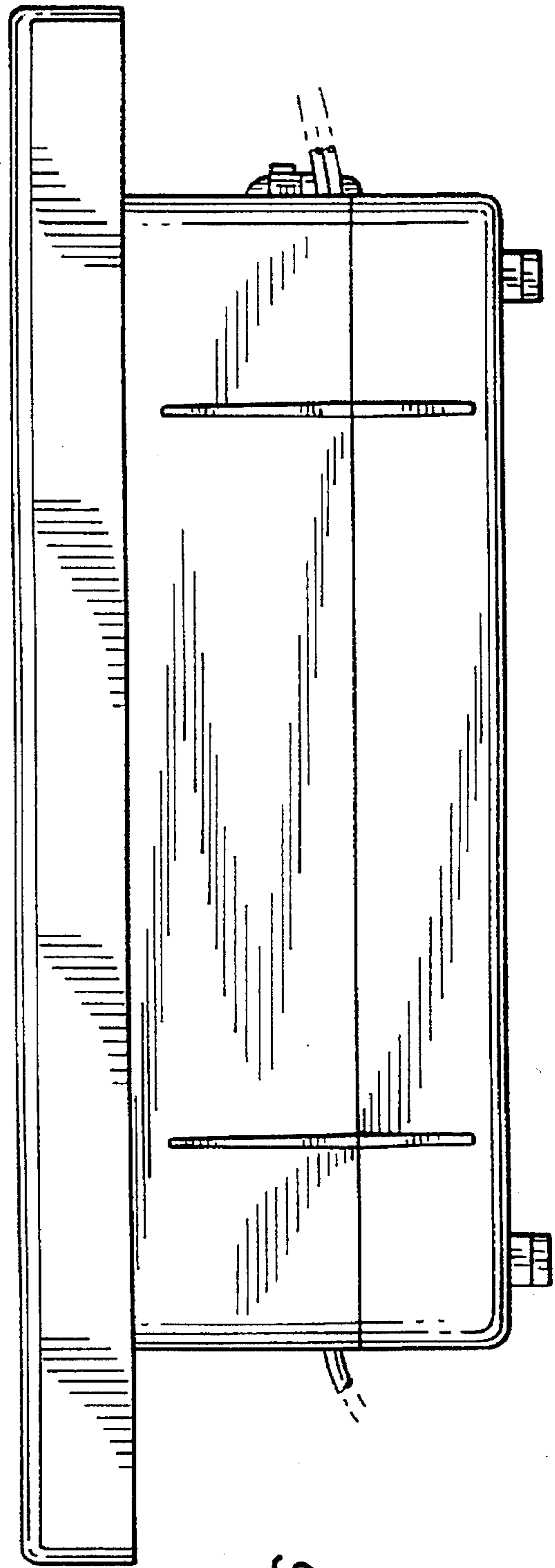

FIG. 6

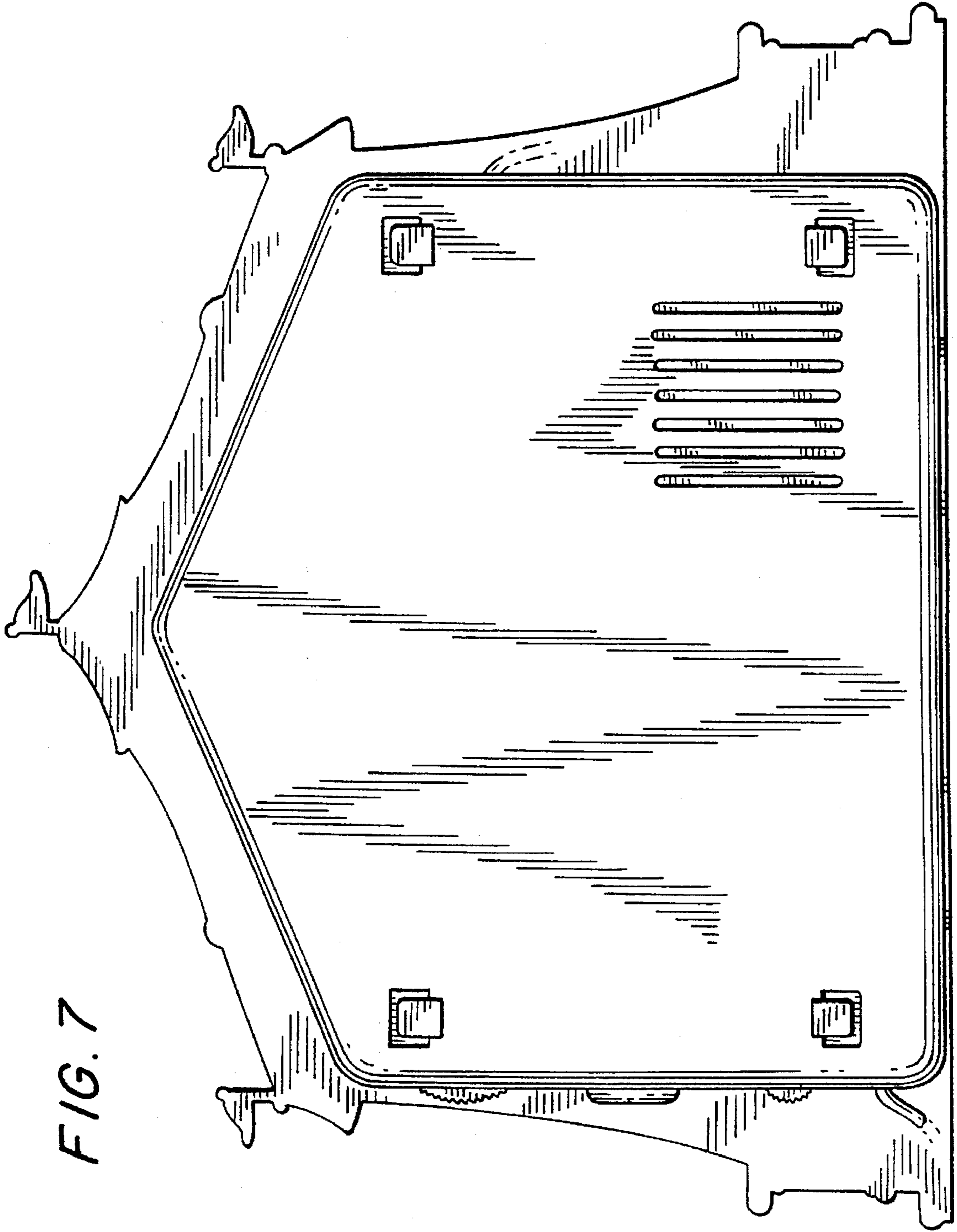

FIG. 7

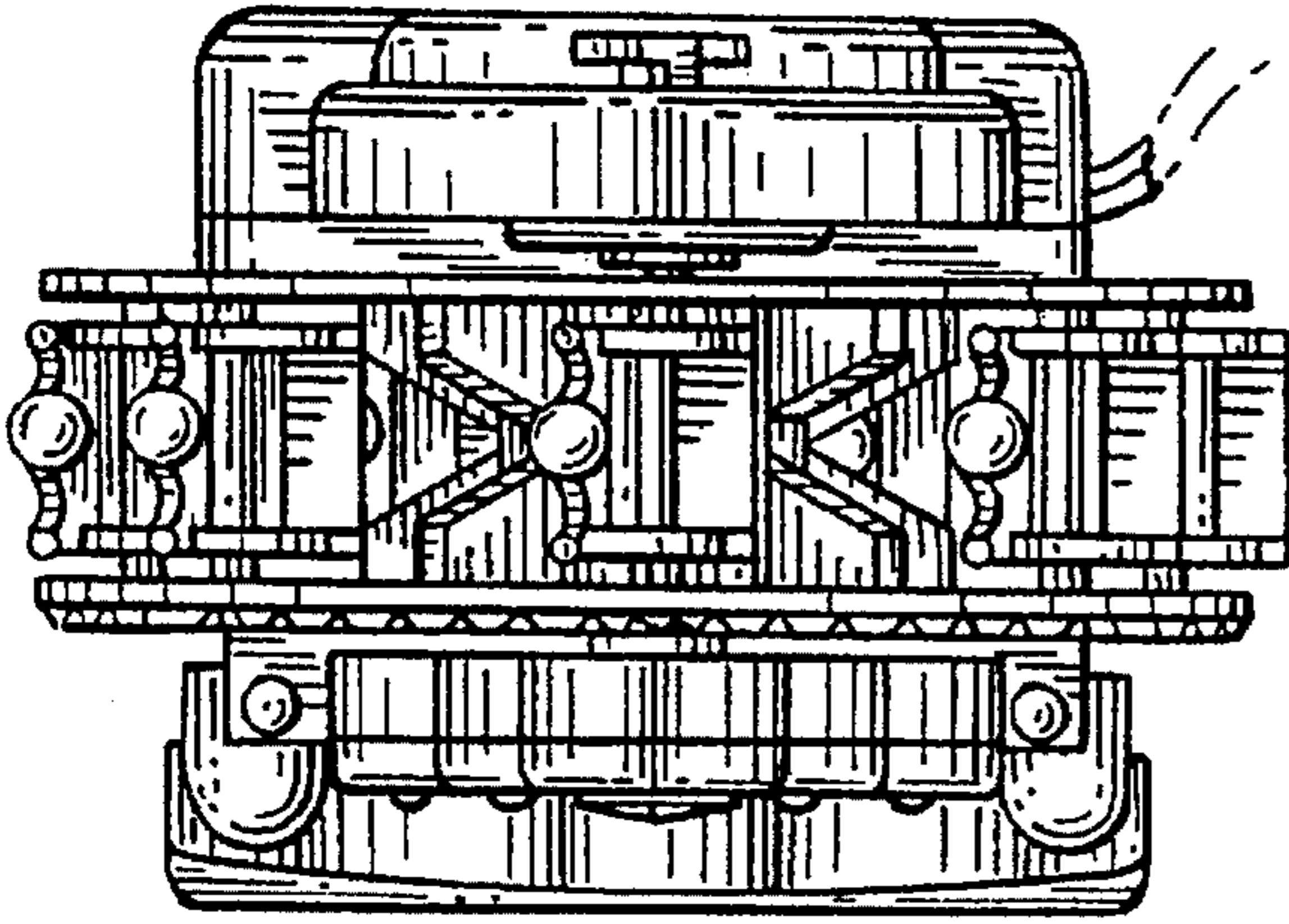

FIG. 8

FIG. 9

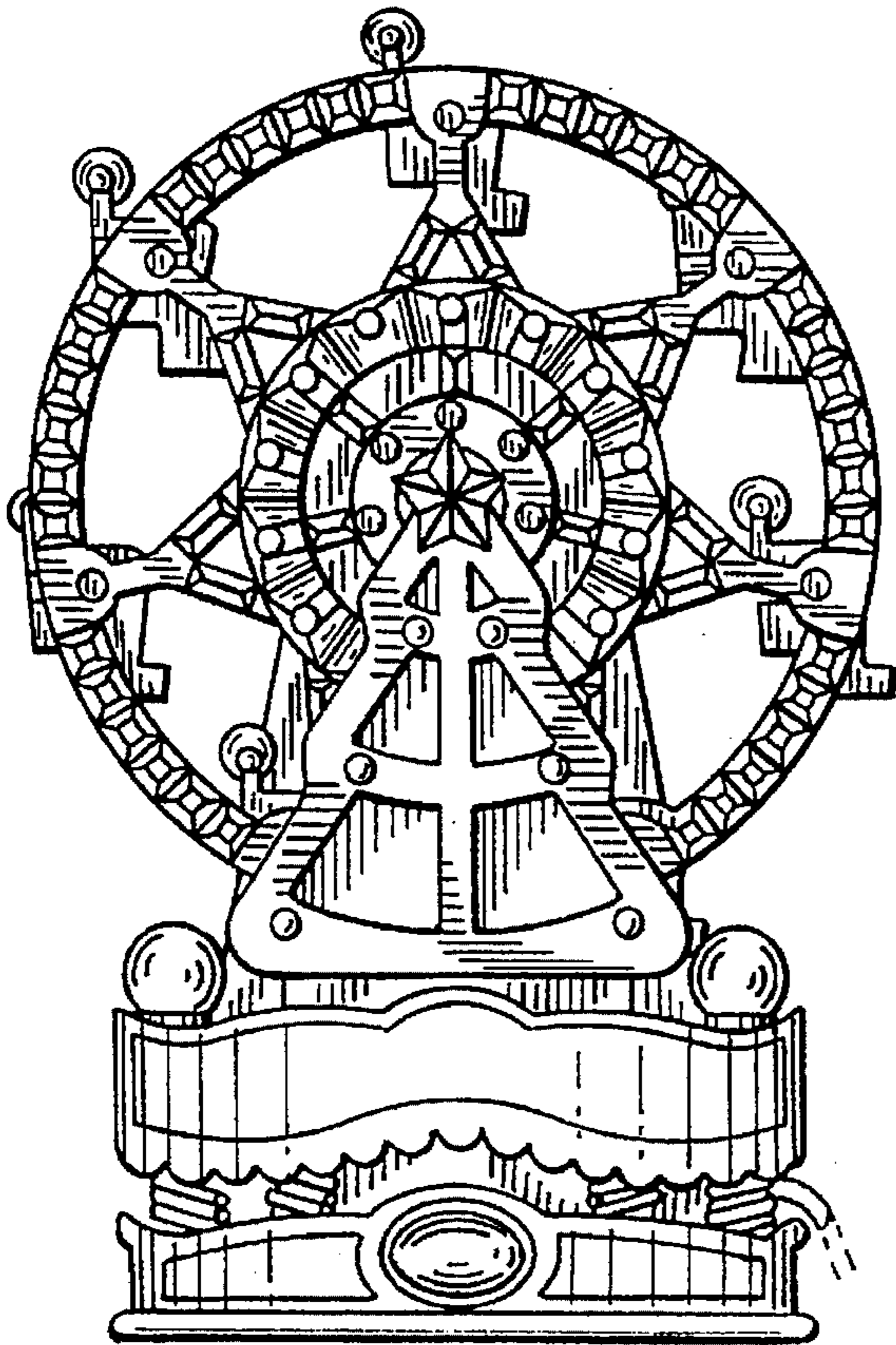

FIG. 10

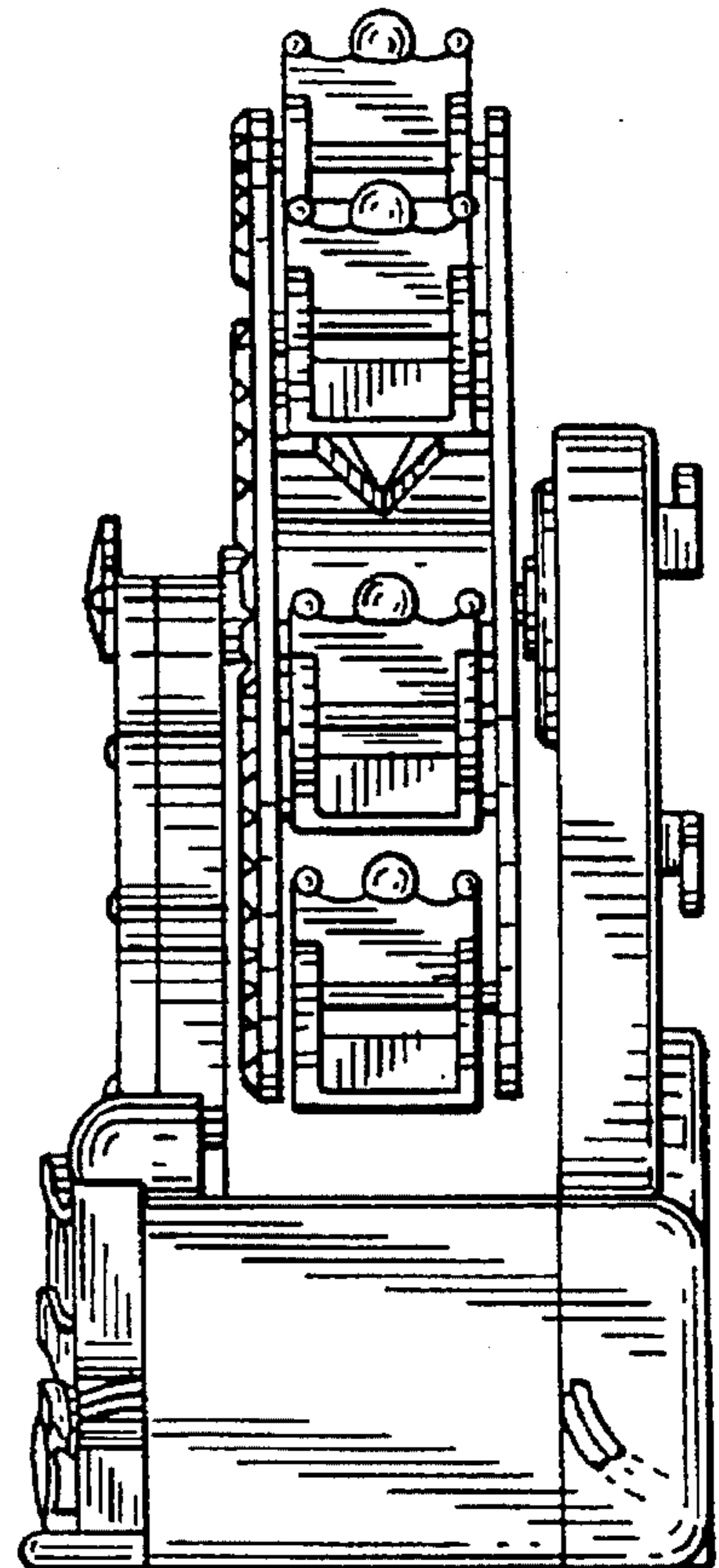

FIG. 11

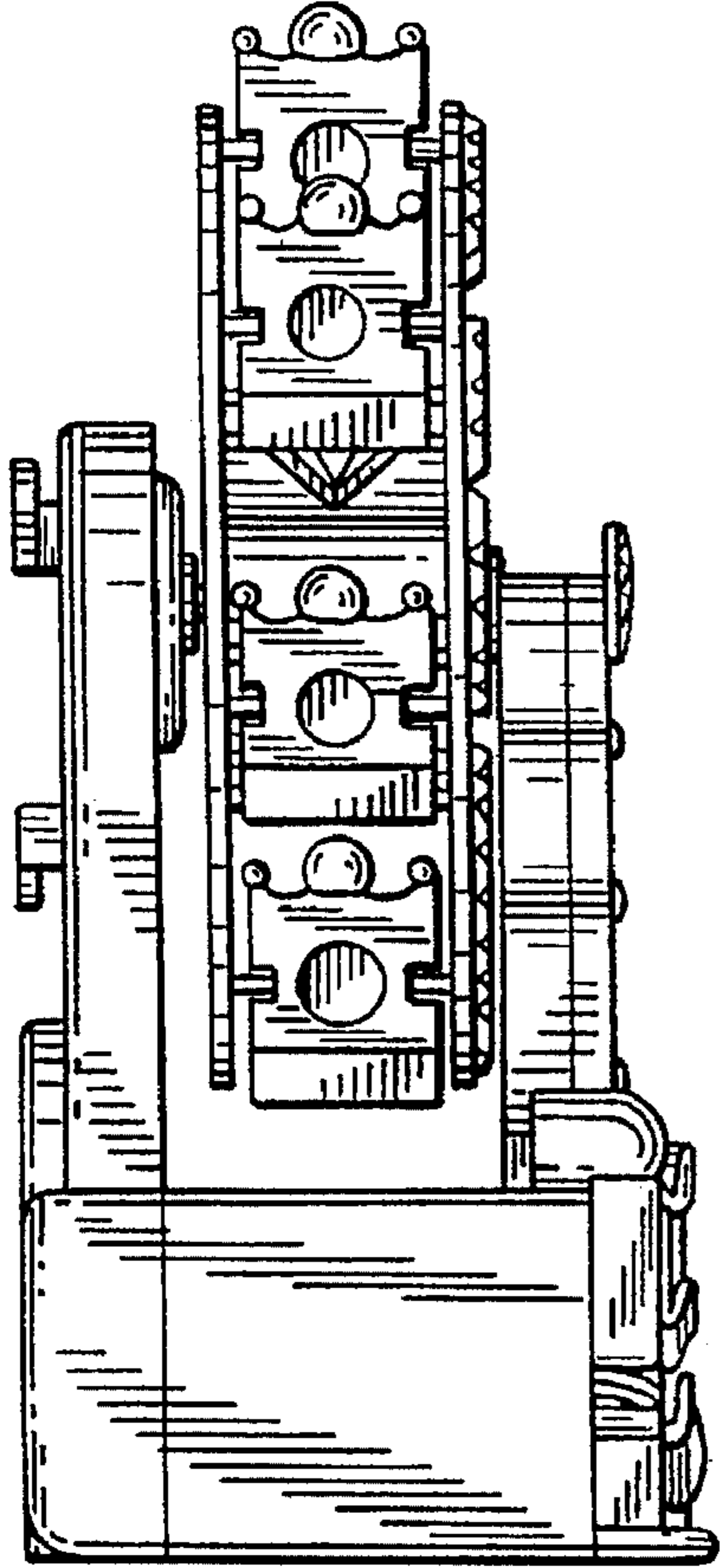

FIG. 12

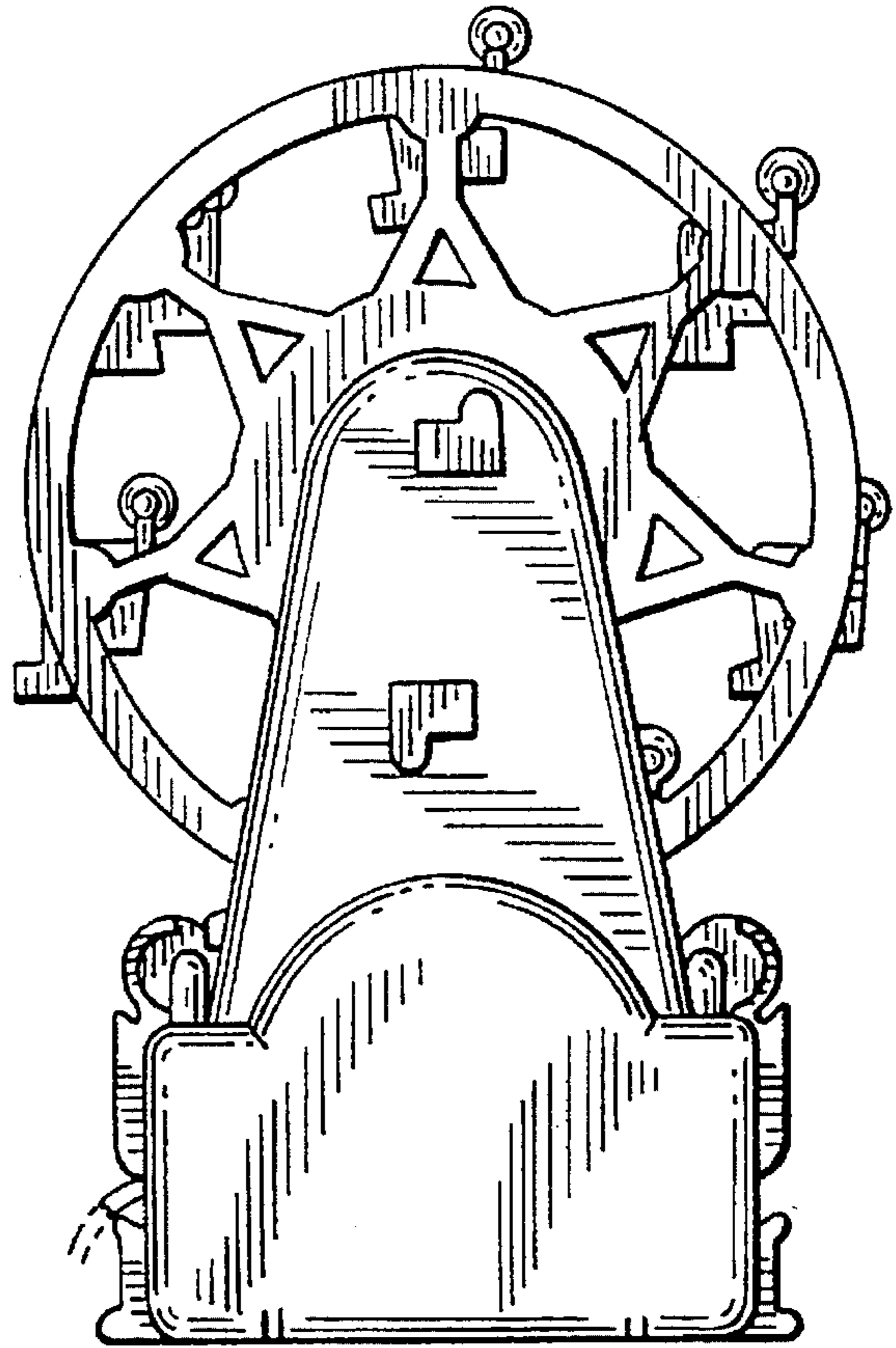
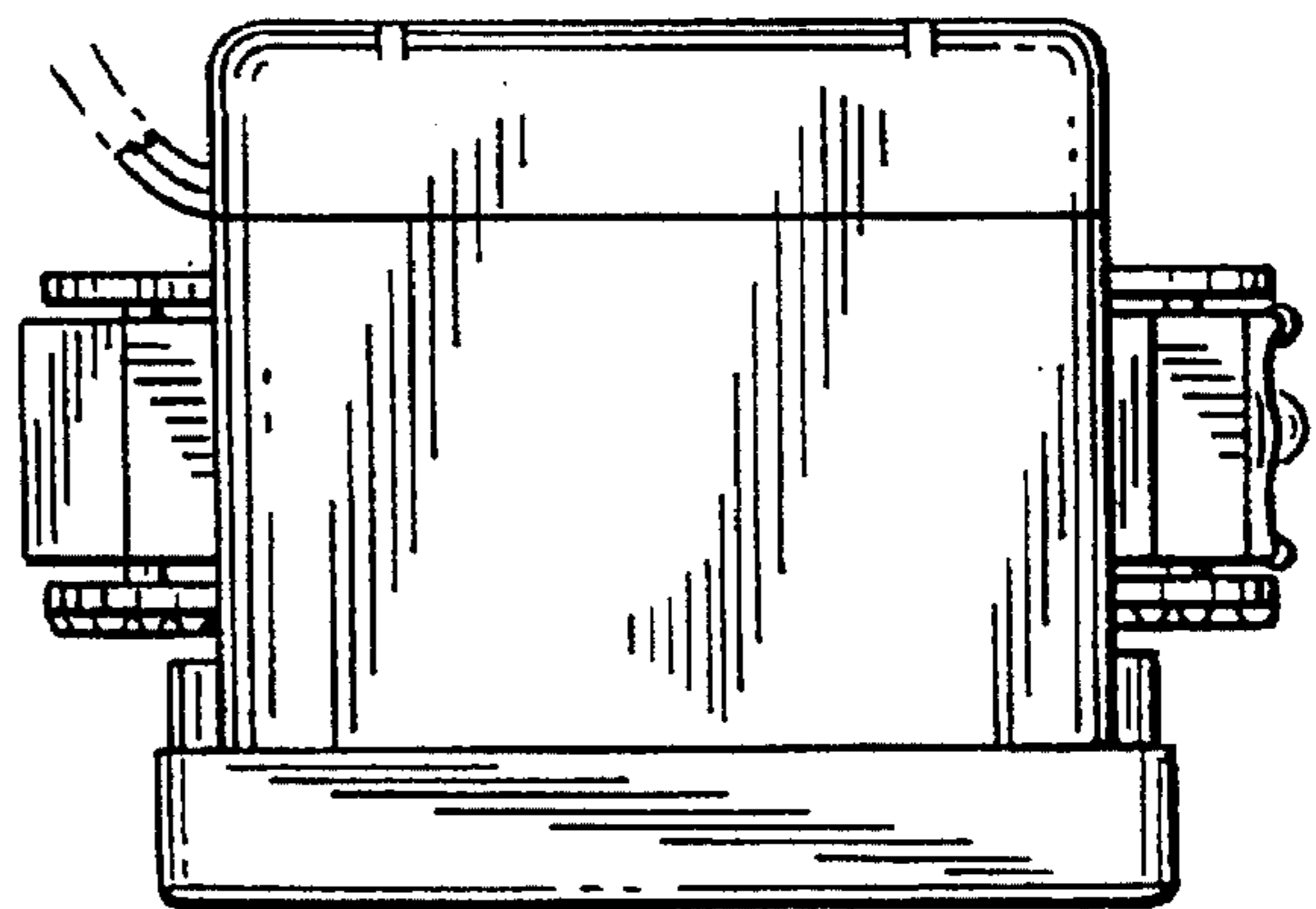

FIG. 13



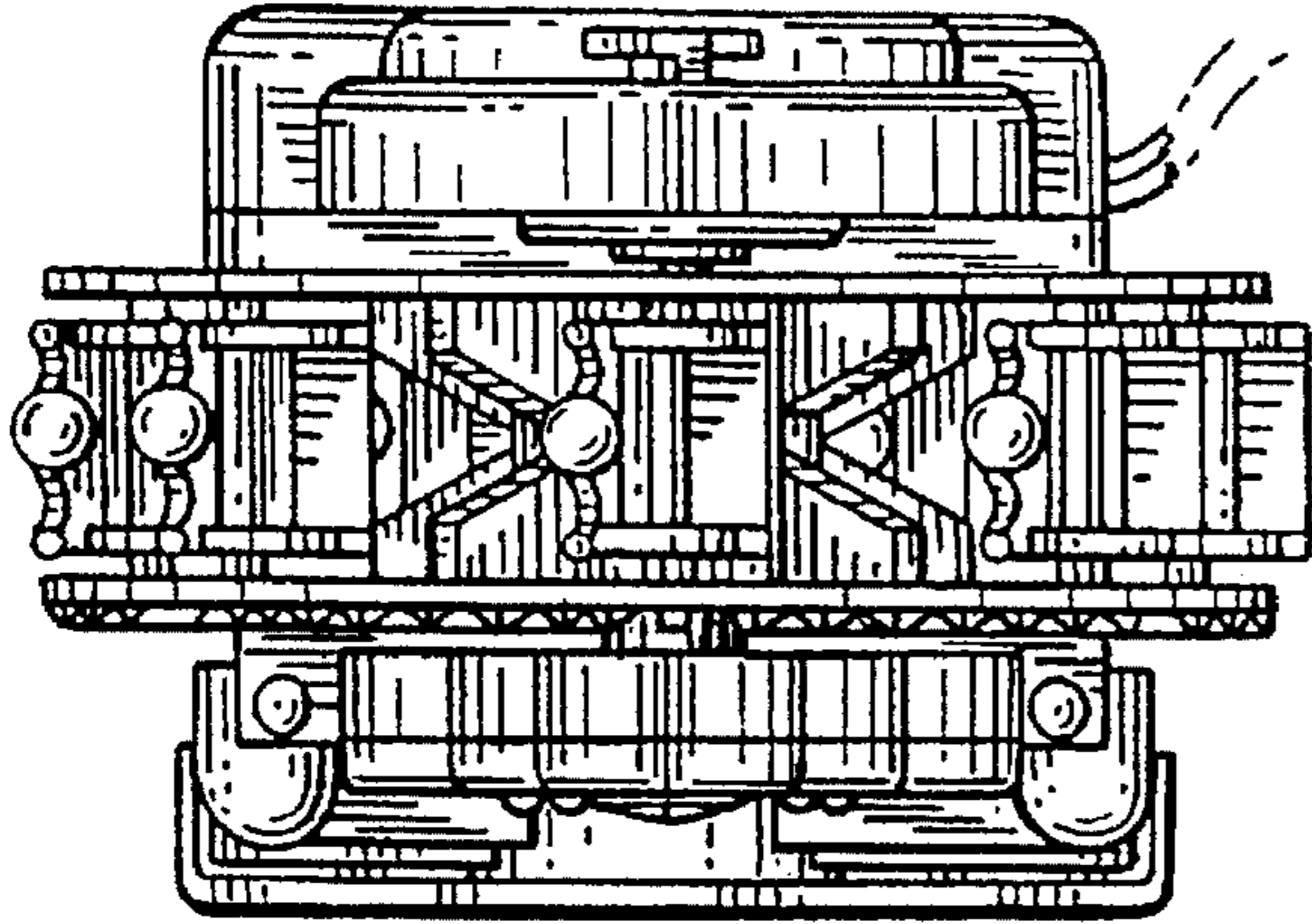

FIG. 14

FIG. 15

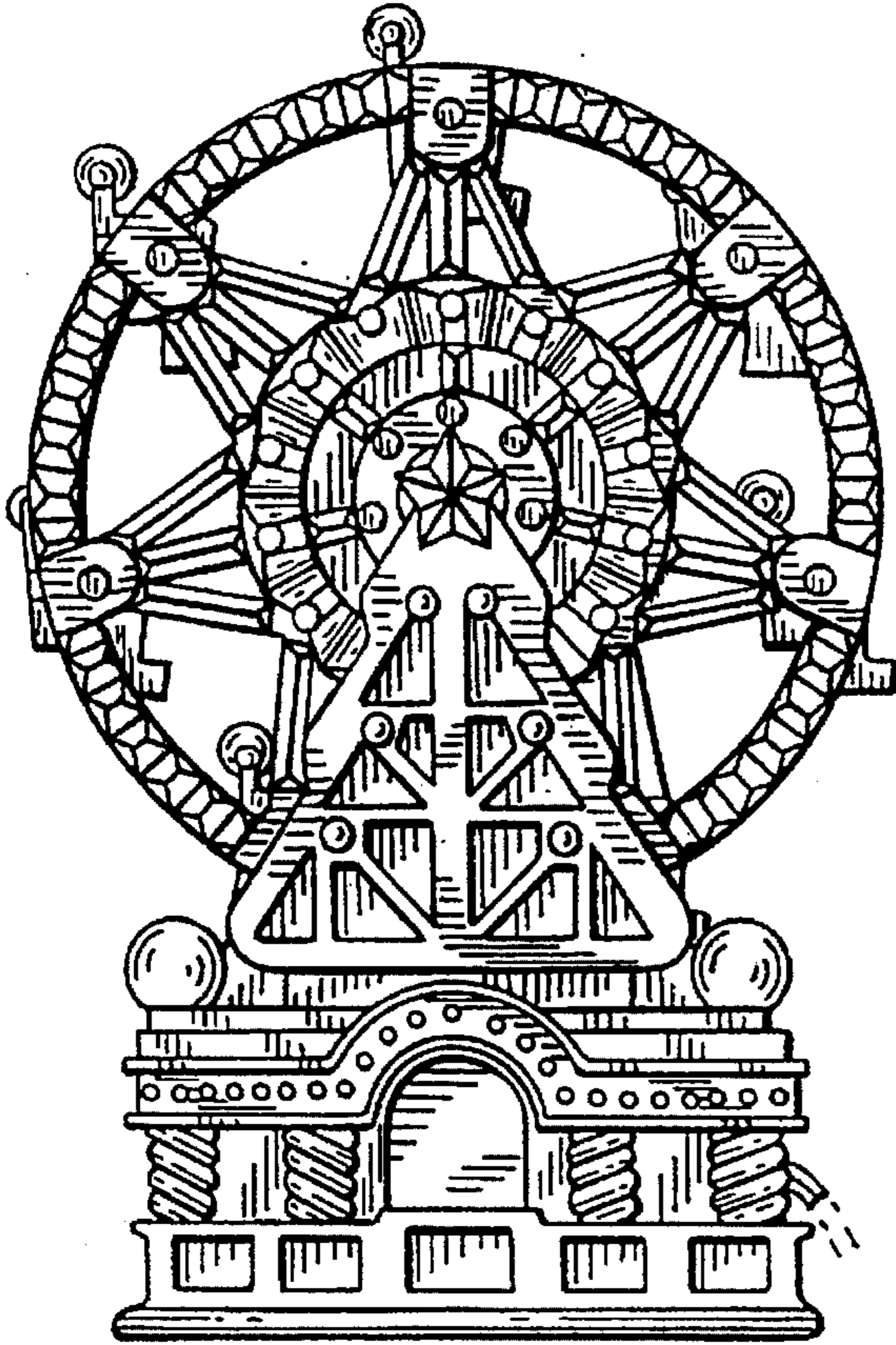

FIG. 16

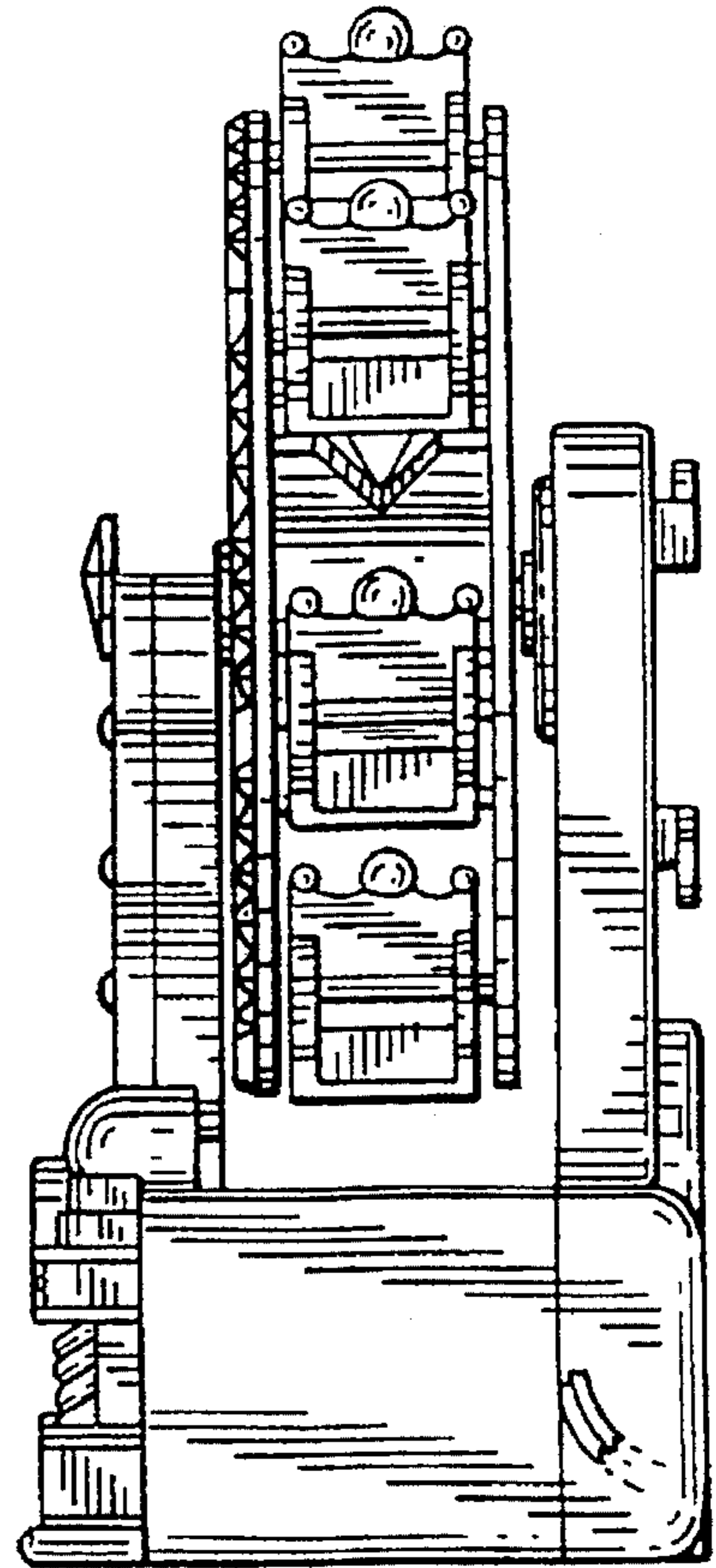

FIG. 17

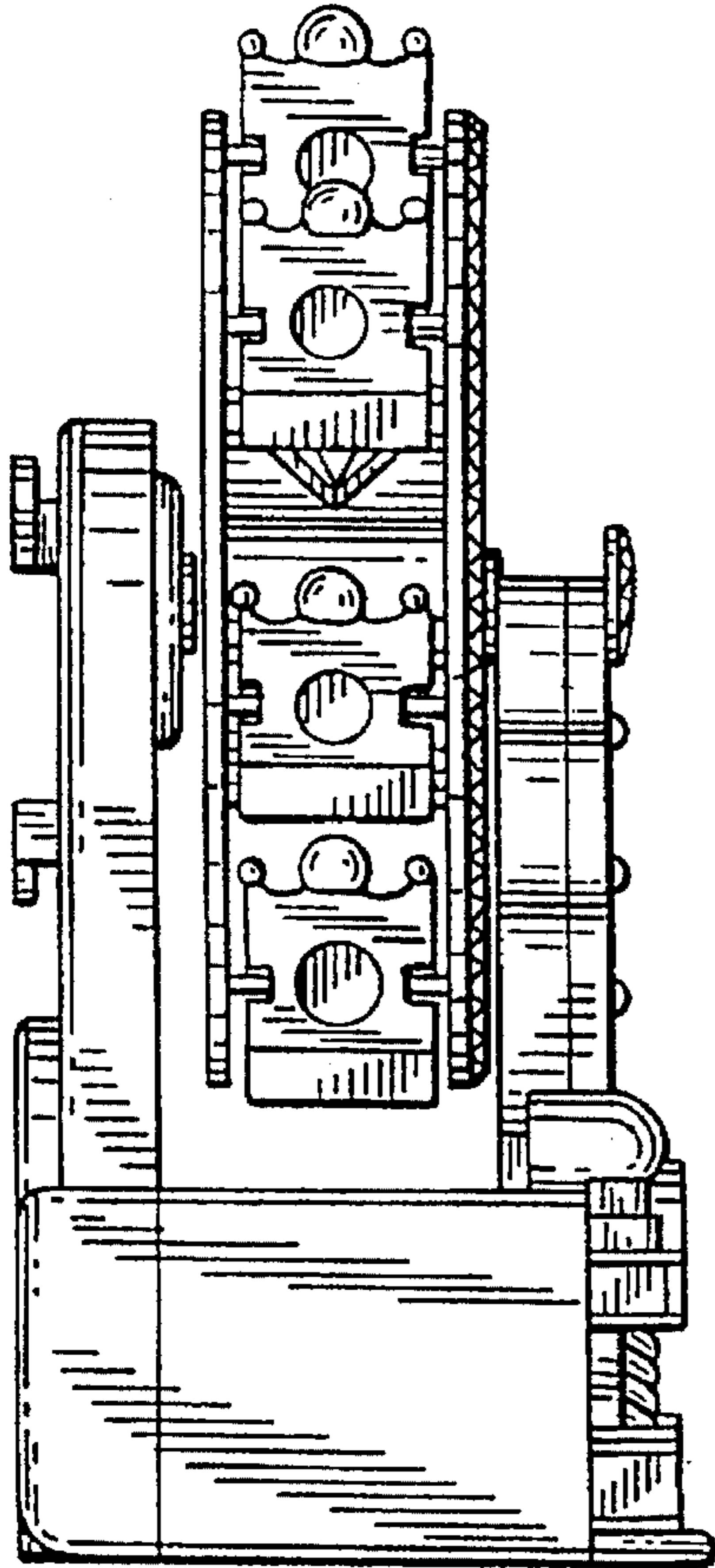

FIG. 18

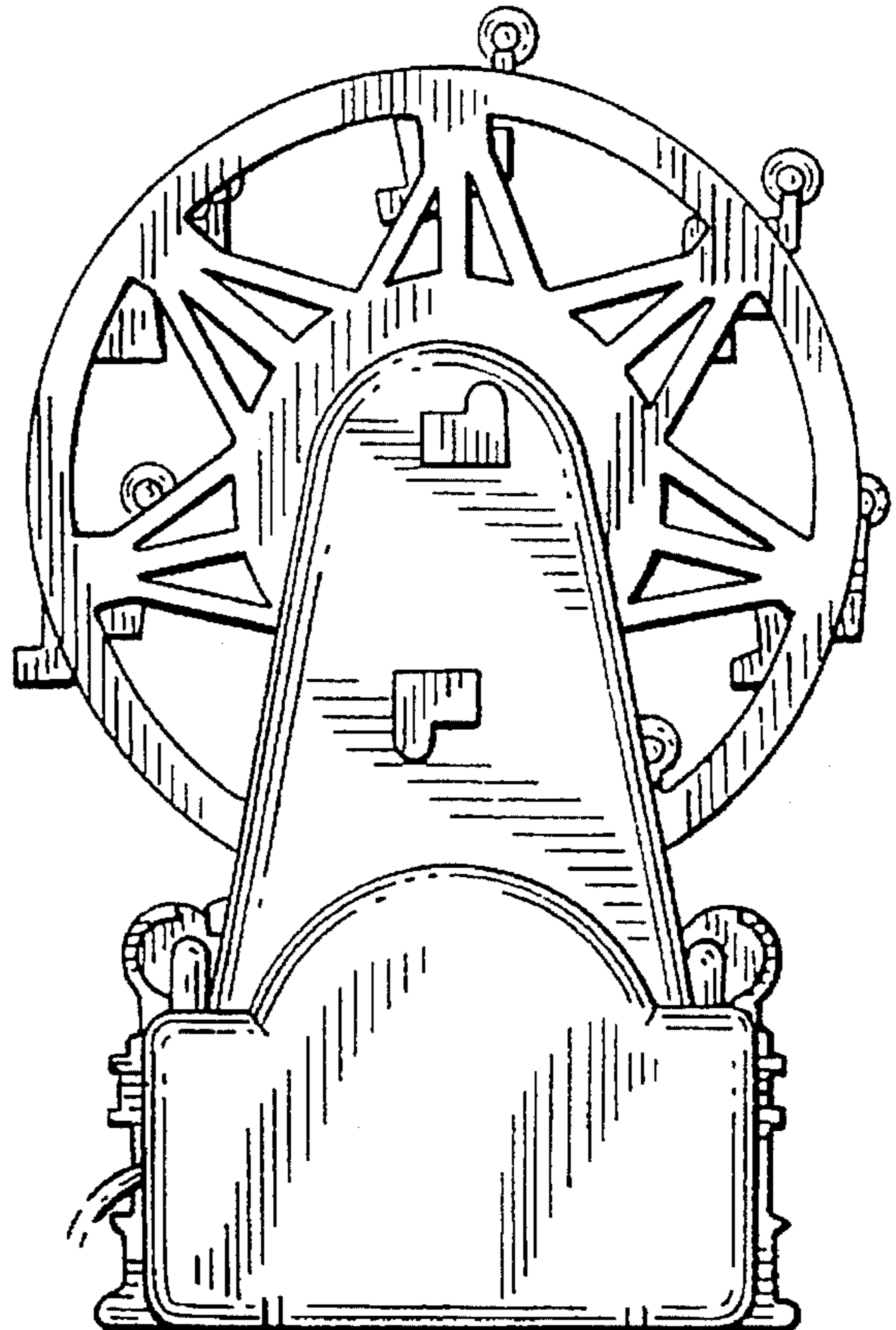
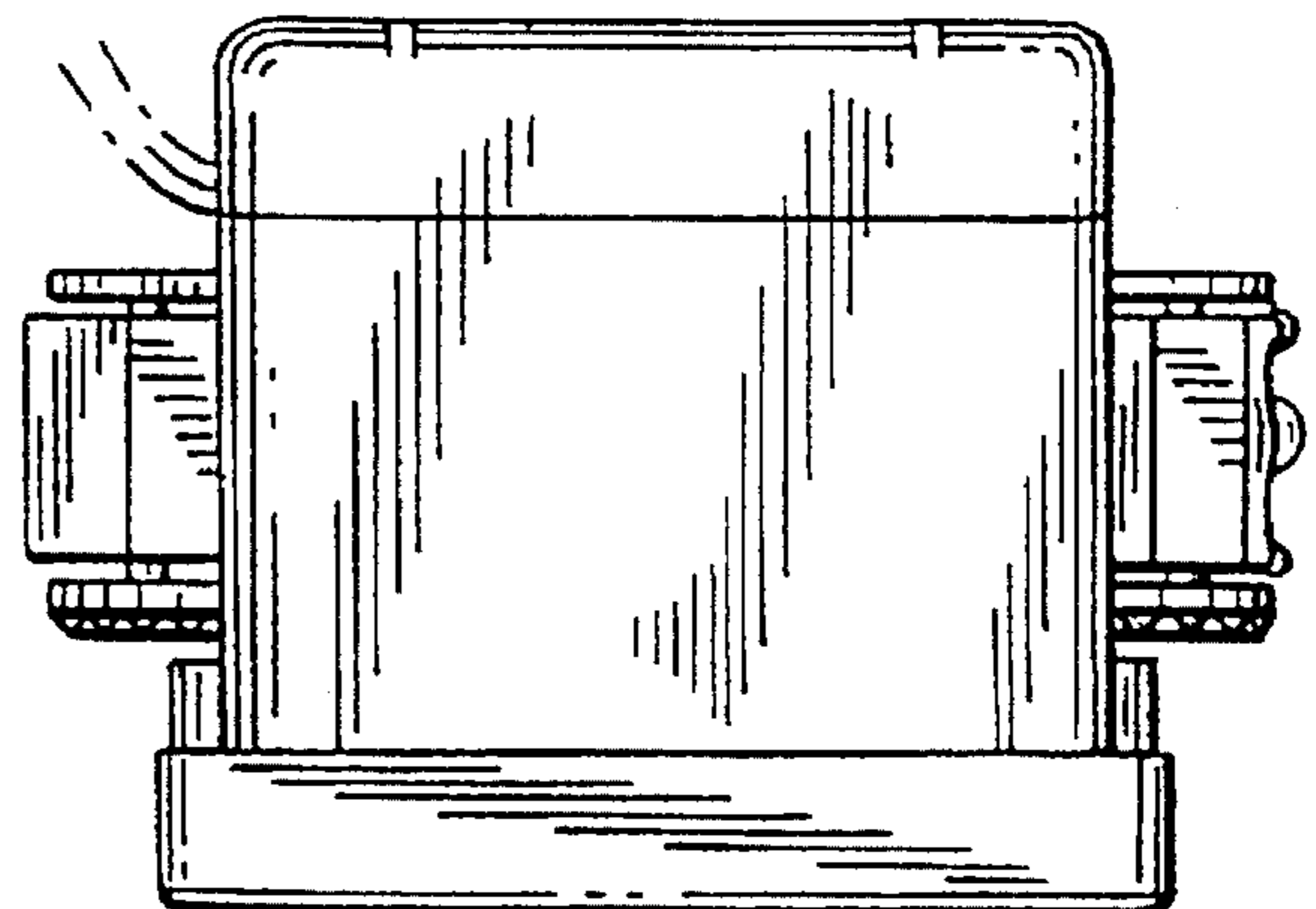

FIG. 19



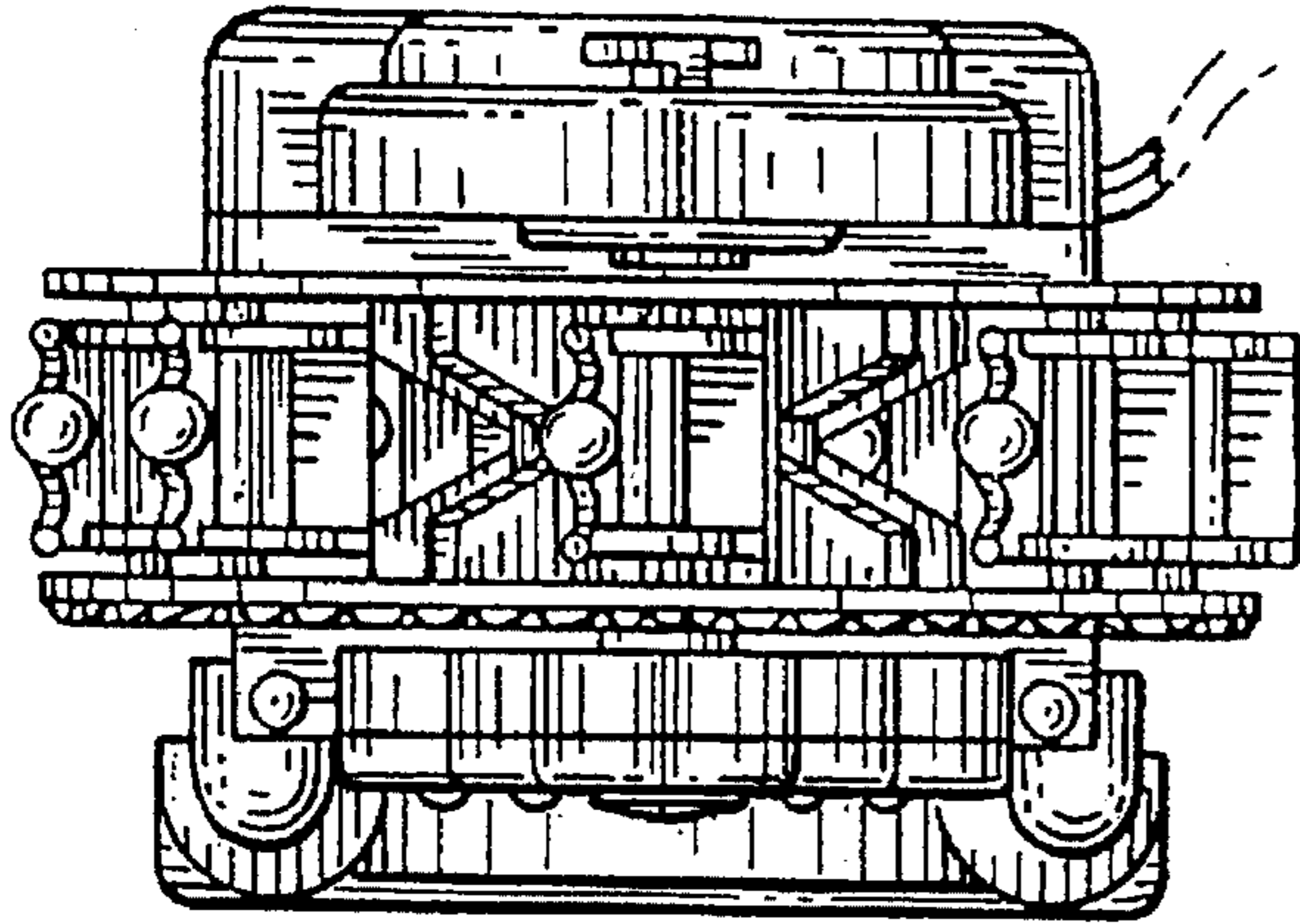

FIG. 20

FIG. 21

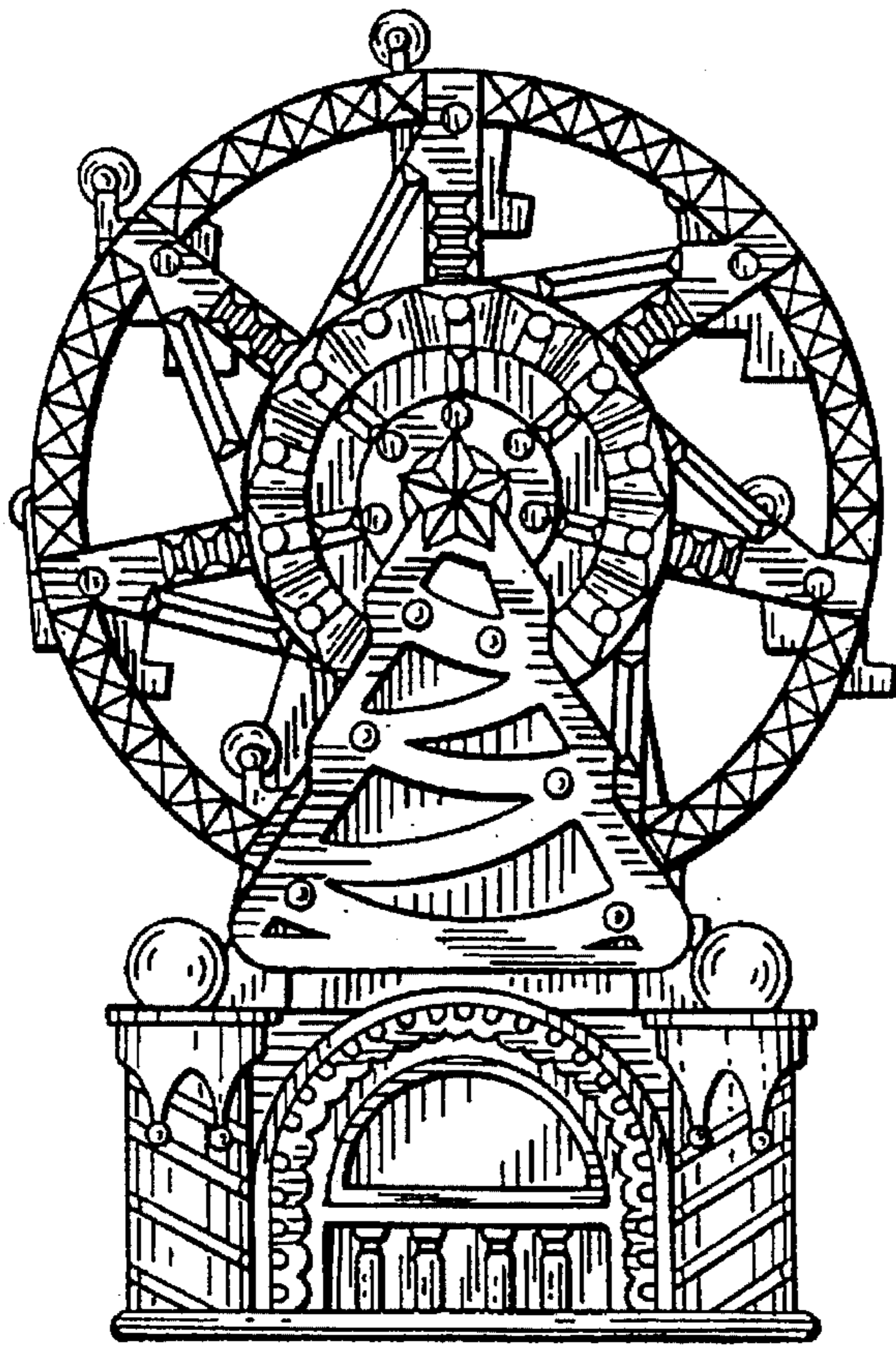

FIG. 22

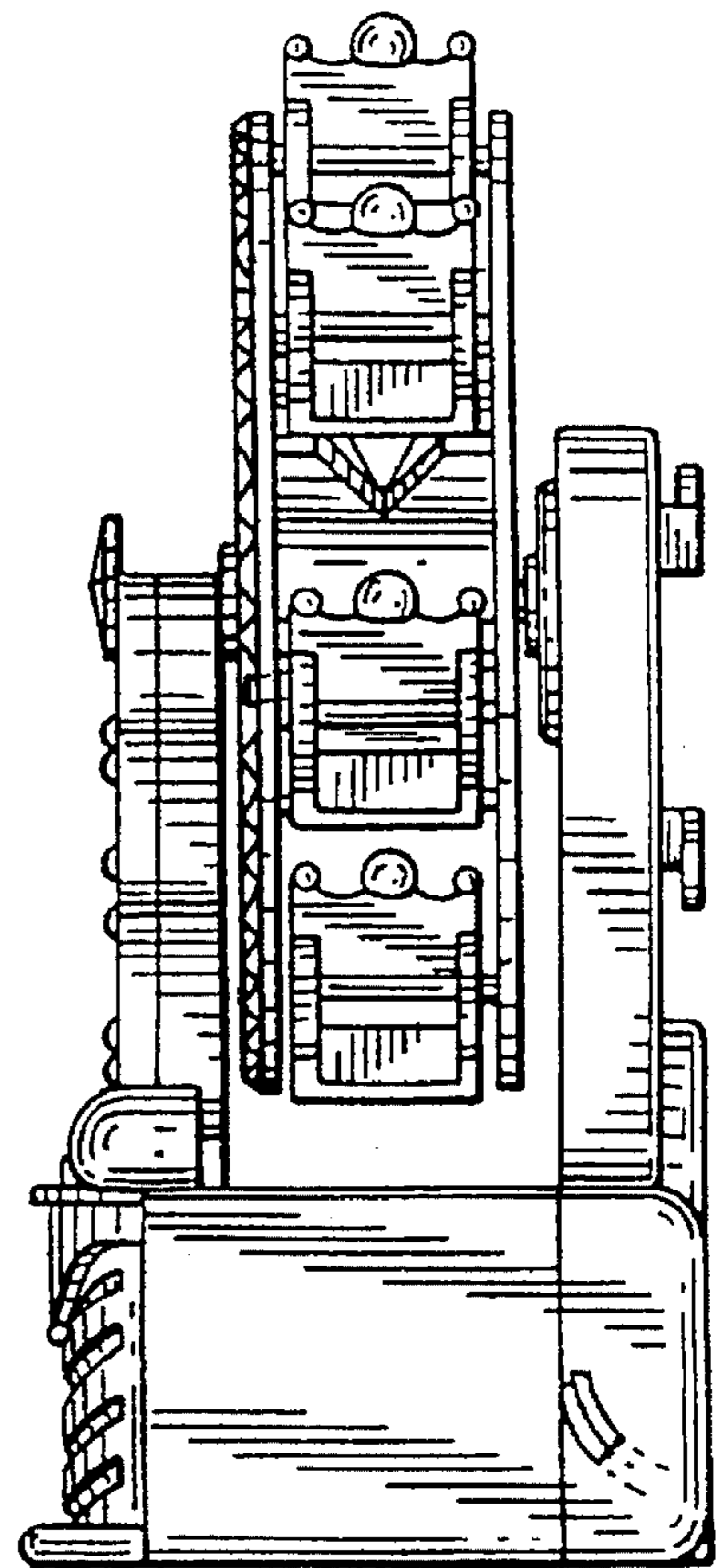

FIG. 23

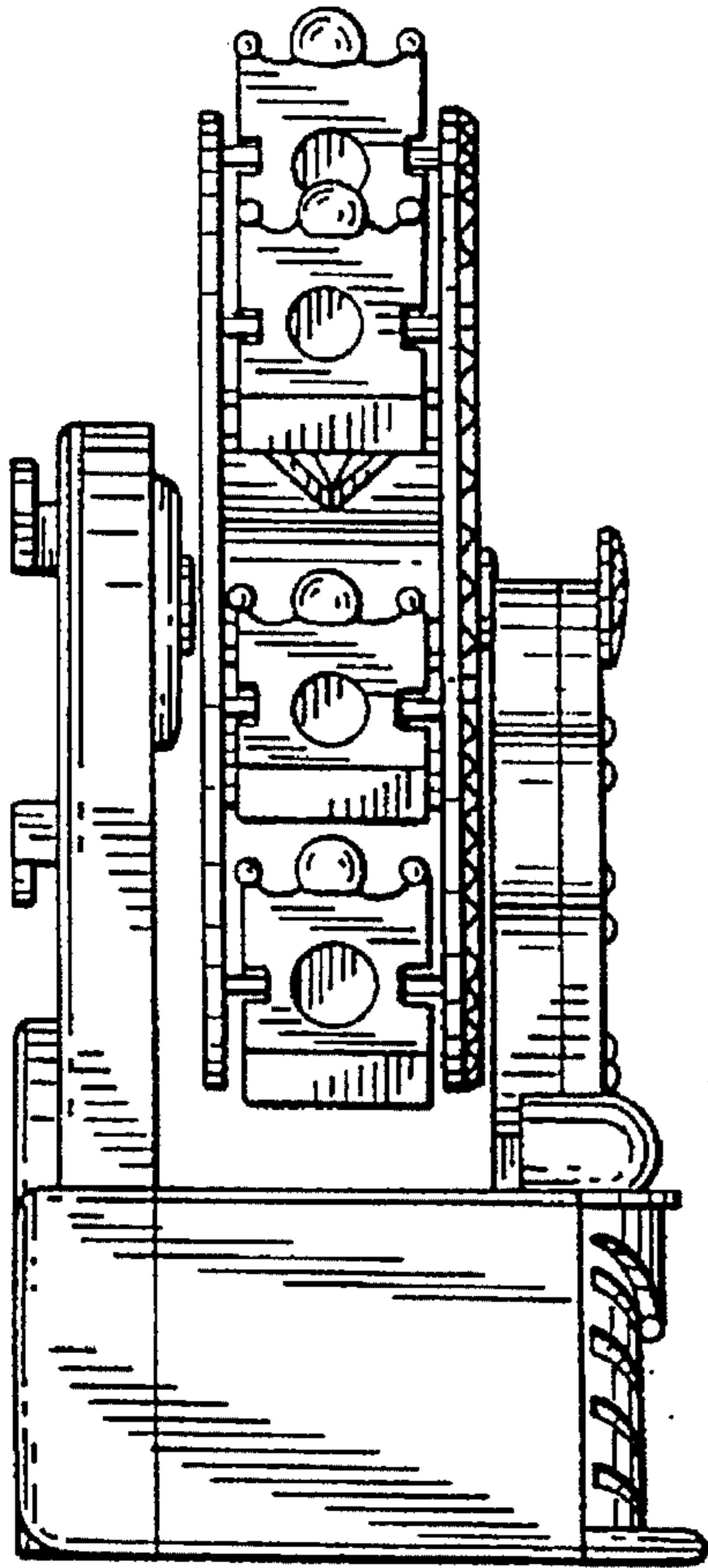

FIG. 24

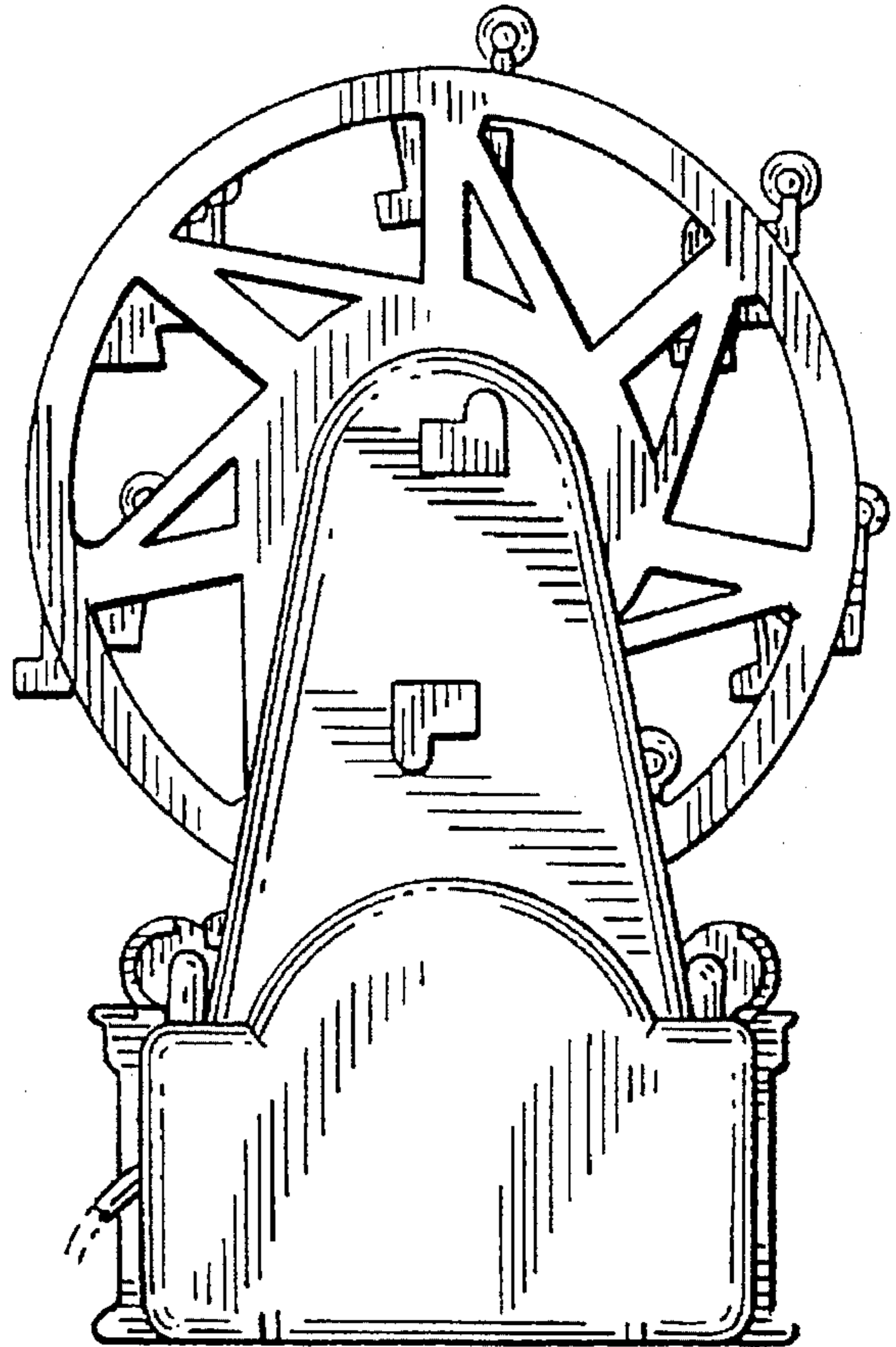

FIG. 25

