



US00D379754S

United States Patent [19] Solow

[11] Patent Number: **Des. 379,754**
[45] Date of Patent: ****Jun. 10, 1997**

[54] **COMBINED AUTOMOBILE STEERING
WHEEL LOCK AND ALARM**

5,163,309 11/1992 Wu 70/209
5,258,741 11/1993 Fuller .
5,398,017 3/1995 Chen .

[75] Inventor: **Joseph E. Solow, Deer Park, N.Y.**

Primary Examiner—Brian N. Vinson
Attorney, Agent, or Firm—Brumbaugh, Graves, Donohue &
Raymond

[73] Assignee: **Wolo Manufacturing Corporation,
Deer Park, N.Y.**

[**] Term: **14 Years**

[57] CLAIM

[21] Appl. No.: **40,240**

The ornamental design for a combined automobile steering wheel lock and alarm, as shown and described.

[22] Filed: **Jun. 13, 1995**

DESCRIPTION

[51] LOC (6) Cl. **08-07**

[52] U.S. Cl. **D8/331; D8/332; D8/333**

[58] Field of Search **D8/330-331, 332,
D8/333, 335, 341; 70/207-211, 214-215,
225-226, 237-238; 292/289**

FIG. 1 is a top, front, and right side perspective view of a combined steering wheel lock and alarm showing my new design, the broken-line disclosure of a portion of a steering wheel and dashboard being for illustrative purposes only and forming no part of the claimed design;

FIG. 2 is a top plan view thereof;

FIG. 3 is a front elevational view thereof;

FIG. 4 is a left side elevational view thereof;

FIG. 5 is a right side elevational view thereof;

FIG. 6 is a rear elevational view thereof; and,

FIG. 7 is a bottom plan view thereof.

[56] References Cited

U.S. PATENT DOCUMENTS

D. 331,870	12/1992	Fuller	D8/331
D. 333,970	3/1993	Starmer	D8/331
D. 348,209	6/1994	Chen	D8/331
D. 350,274	9/1994	Baker	D8/331
D. 356,242	3/1995	Lo	D8/331

1 Claim, 4 Drawing Sheets

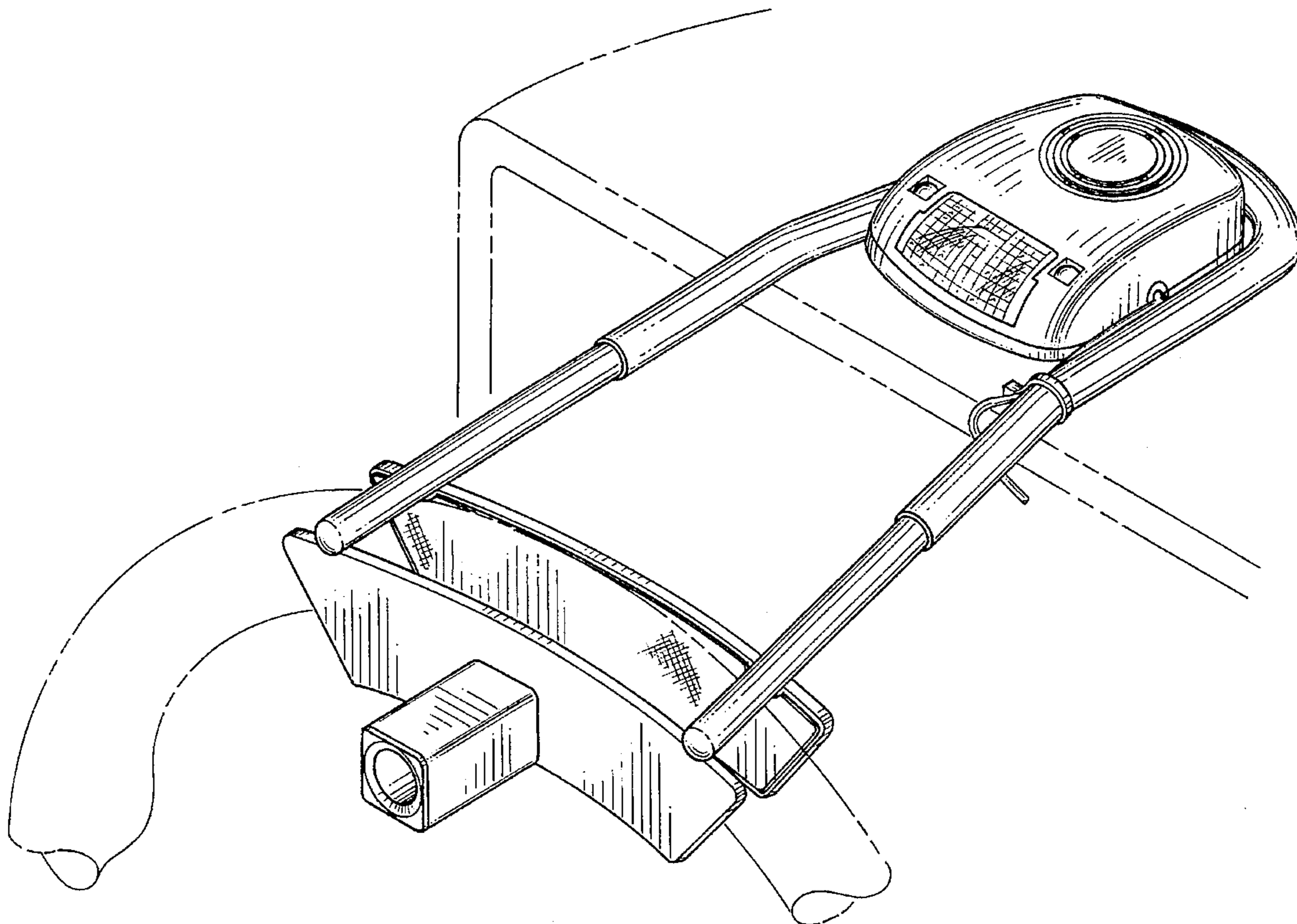

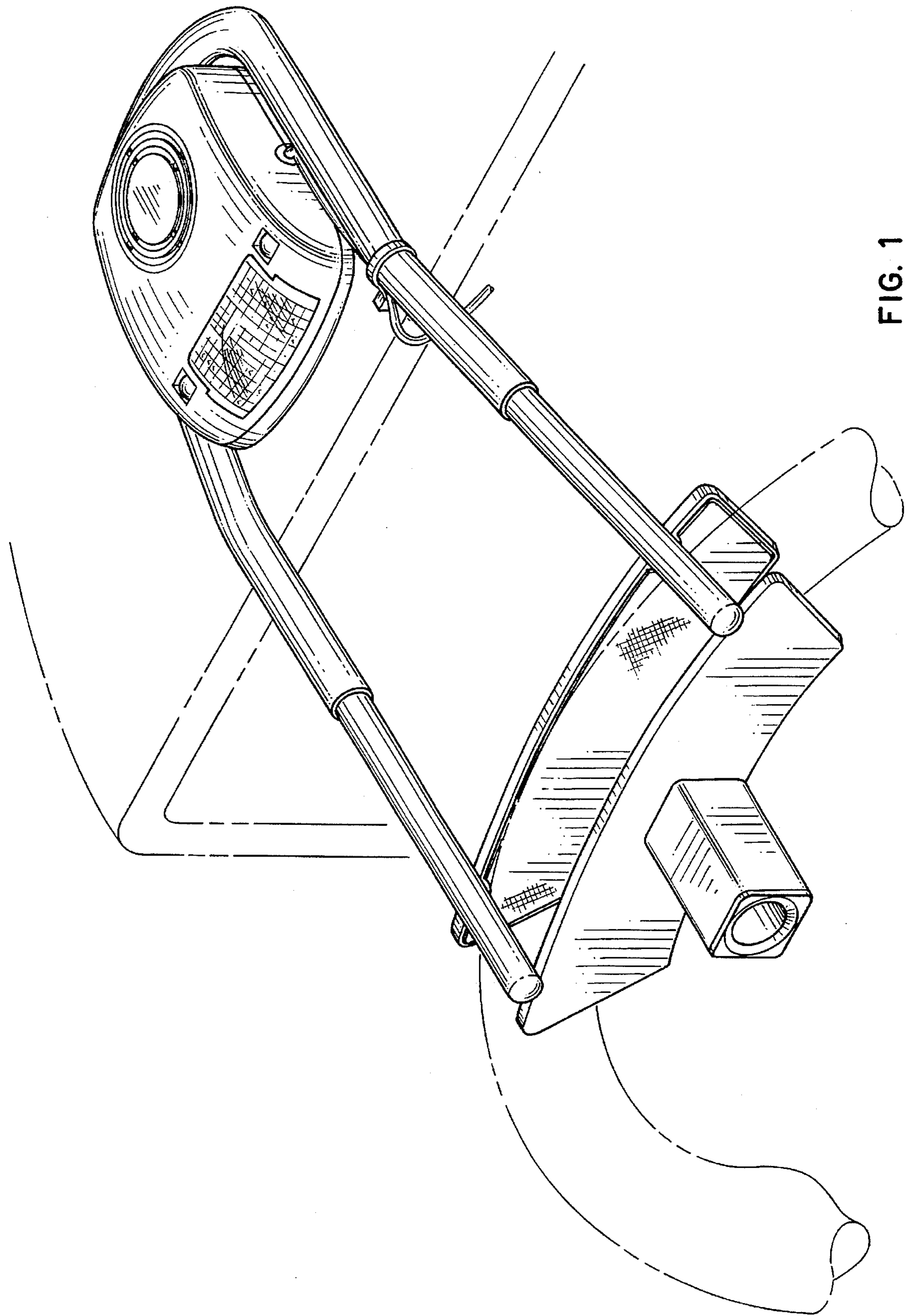

FIG. 1

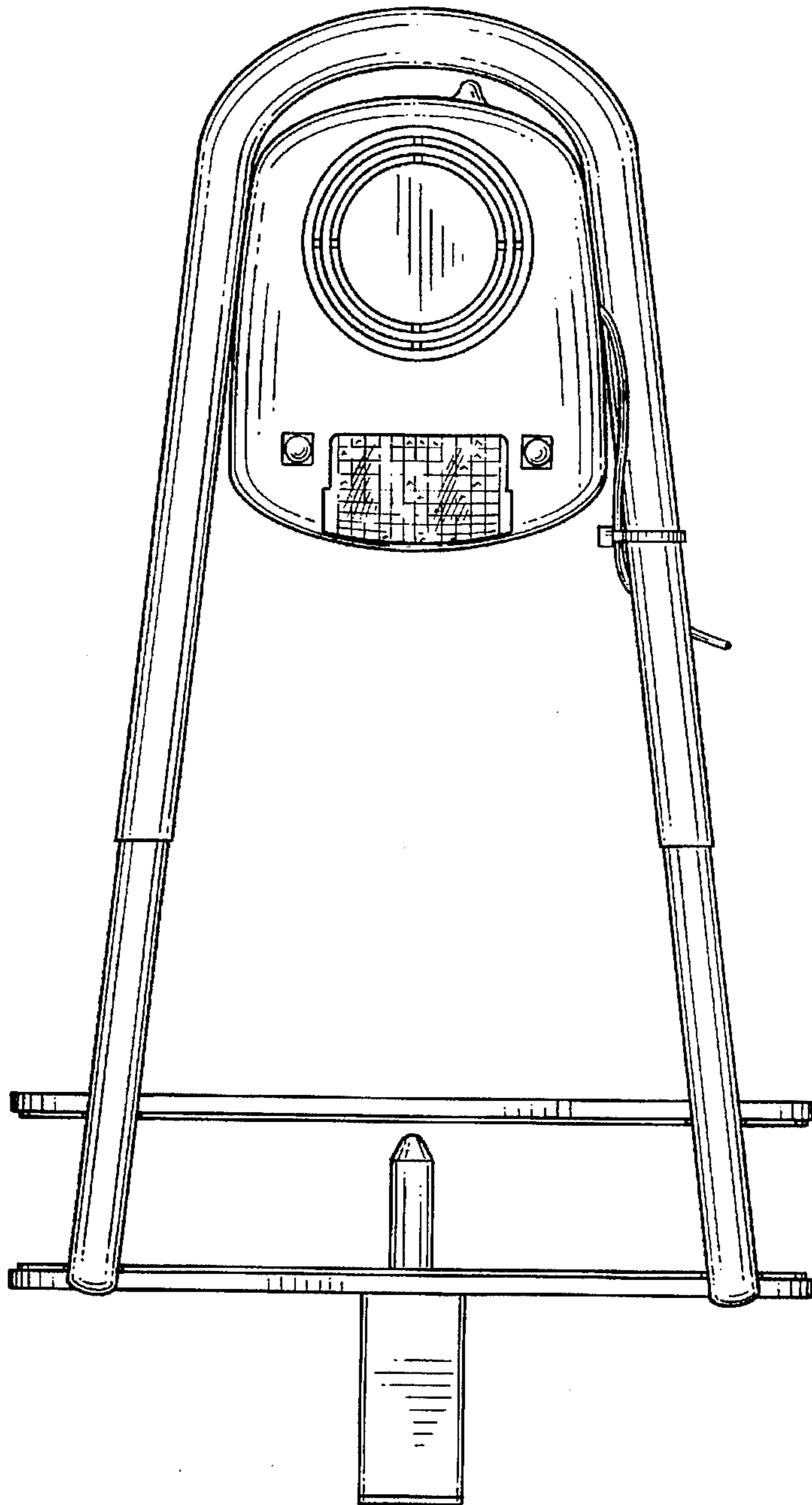

FIG. 2

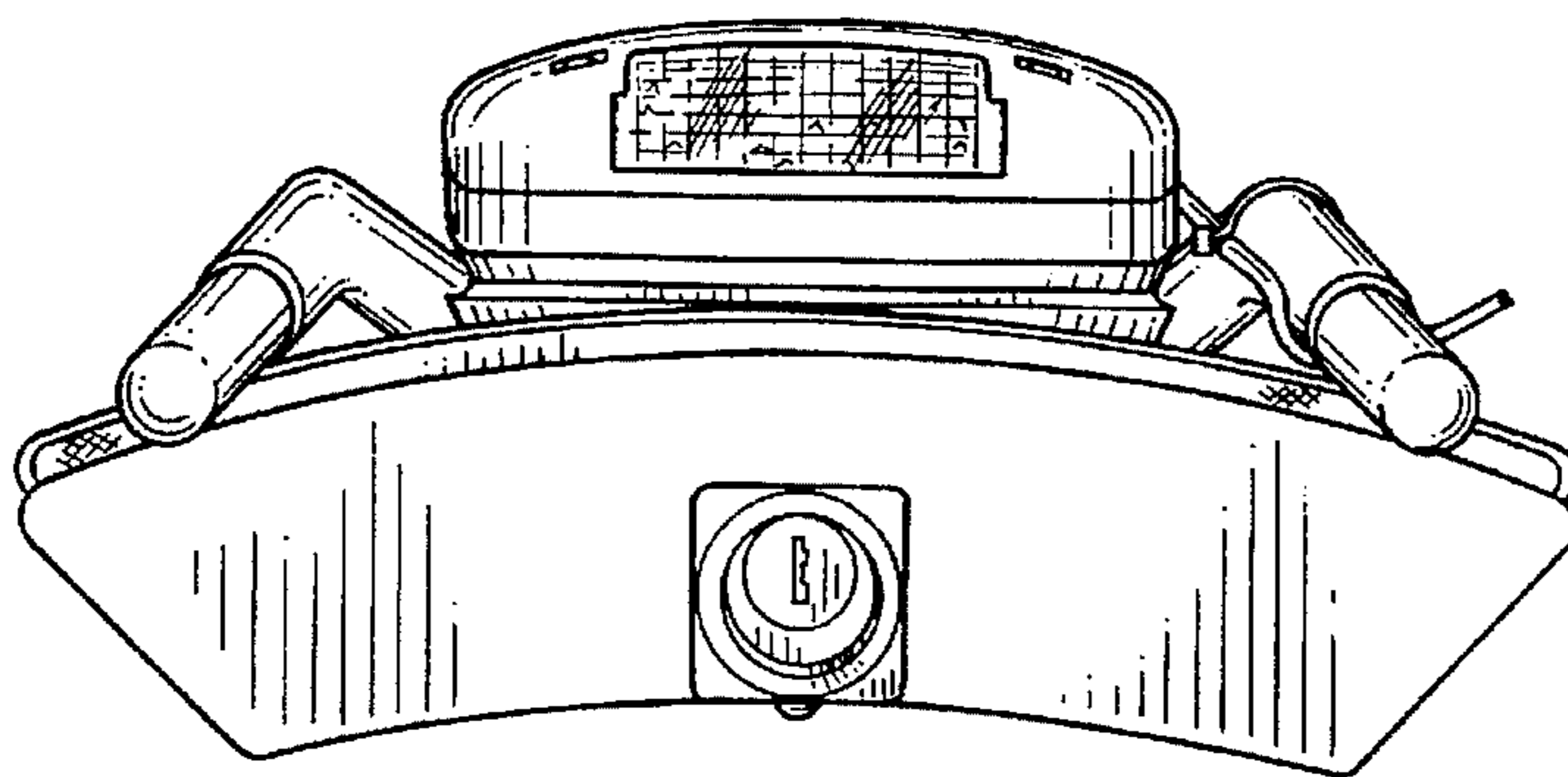

FIG. 3

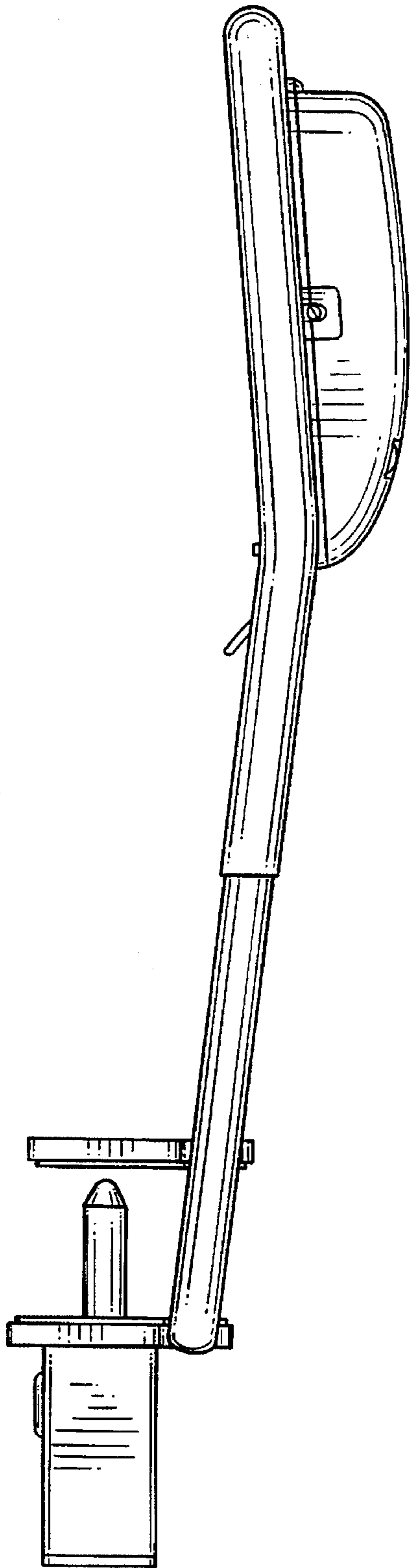

FIG. 4

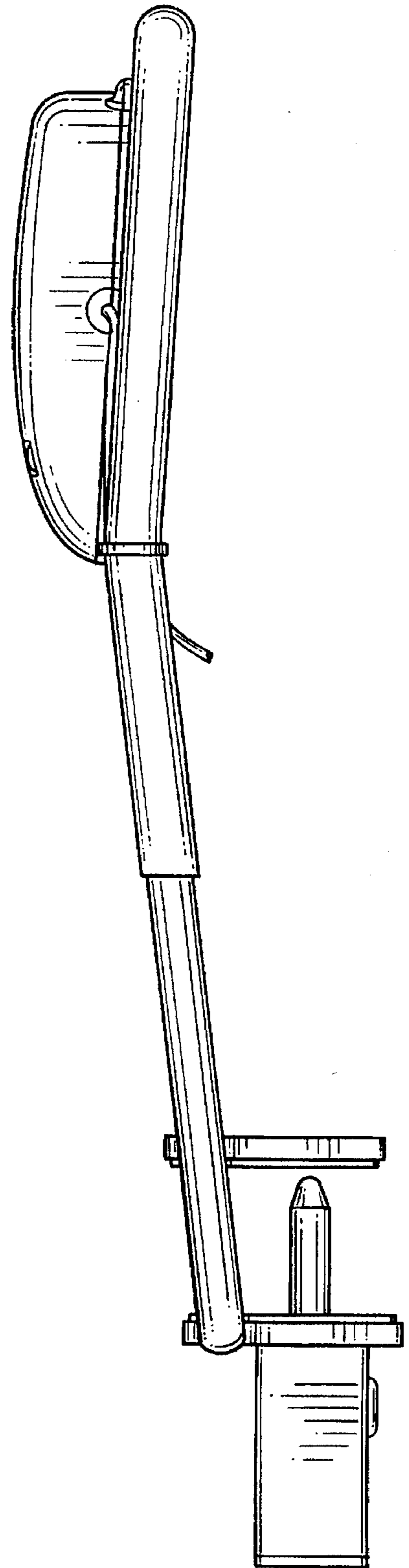

FIG. 5

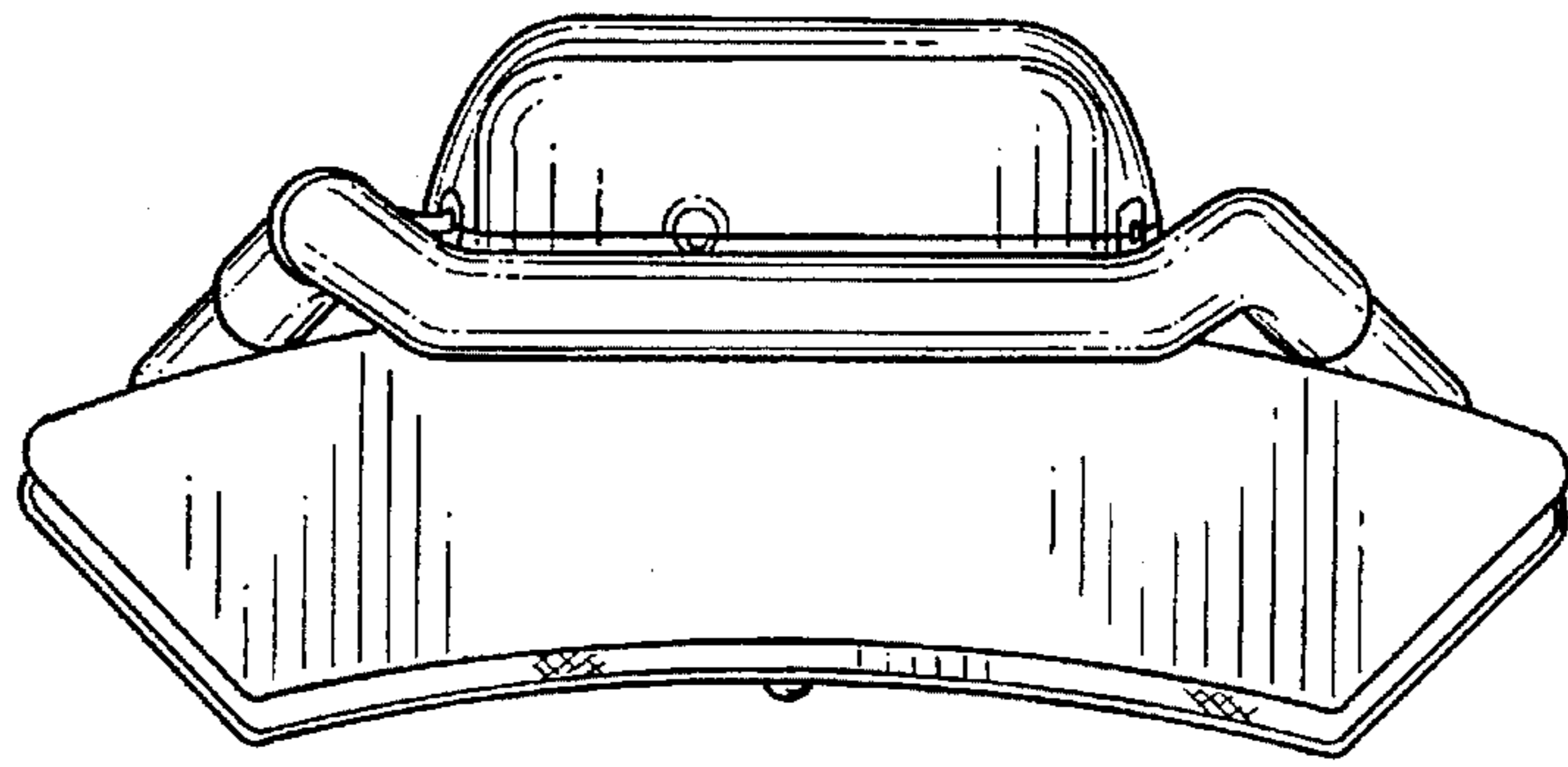

FIG. 6

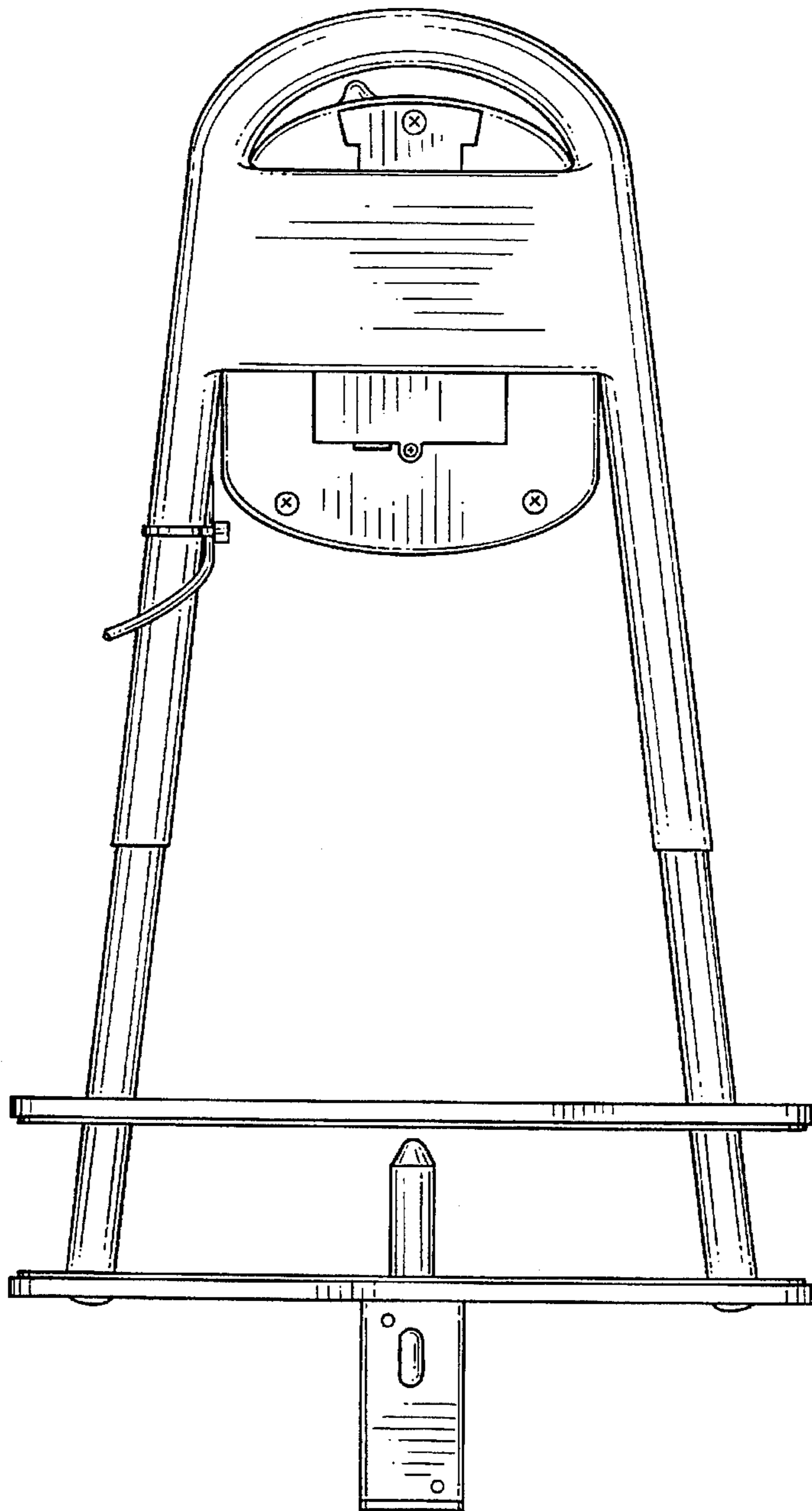

FIG. 7