



US00D379299S

United States Patent [19]
Fitzgibbons

[11] **Patent Number:** **Des. 379,299**
[45] **Date of Patent:** ****May 20, 1997**

[54] **SAFETY DOOR STOP**

[76] **Inventor:** **James Fitzgibbons**, 408 Hulse Ave.,
Brick, N.J. 08724

[**] **Term:** **14 Years**

[21] **Appl. No.:** **53,868**

[22] **Filed:** **May 1, 1996**

[51] **LOC (6) Cl.** **08-09**

[52] **U.S. Cl.** **D8/402; D8/395; D25/119**

[58] **Field of Search** **D8/400, 402, 394-396;**
D25/119; 16/82, 83, 86 R; 292/288, 338,
339, DIG. 19

[56] **References Cited**

U.S. PATENT DOCUMENTS

| | | | | |
|------------|---------|-----------------|-------|-----------|
| D. 302,939 | 8/1989 | Ruskin | | D8/402 |
| 2,428,731 | 10/1947 | Abrams | | 49/490.1 |
| 2,714,525 | 8/1955 | Kessler | | 52/11 X |
| 2,988,390 | 6/1961 | Kramer | | 292/288 |
| 3,758,141 | 9/1973 | Weinberger | | 16/82 X |
| 5,039,246 | 8/1991 | Woodruff et al. | | 160/392 X |

FOREIGN PATENT DOCUMENTS

| | | | | |
|---------|---------|----------------|-------|---------|
| 1211115 | 11/1970 | United Kingdom | | 16/82 |
| 2190135 | 11/1987 | United Kingdom | | 292/288 |

Primary Examiner—Philip S. Hyder
Assistant Examiner—C. Tuttle
Attorney, Agent, or Firm—Charles F. Gunderson

[57] **CLAIM**

The ornamental design for a safety door stop, as shown and described.

DESCRIPTION

FIG. 1 is a top, front, left side perspective of a door stop, showing my new design;

FIG. 2 is a bottom, rear, right side perspective view thereof;

FIG. 3 is a left side elevation thereof;

FIG. 4 is a left side elevation showing the door step positioned on a door; and,

FIG. 5 is a top, front, left side perspective view thereof, in a reduced scale, showing the door stop positioned on a hinged door.

The discontinuous lines shown in FIGS. 4 and 5 are only to illustrate the use thereof, and form no part of the claimed invention.

1 Claim, 1 Drawing Sheet

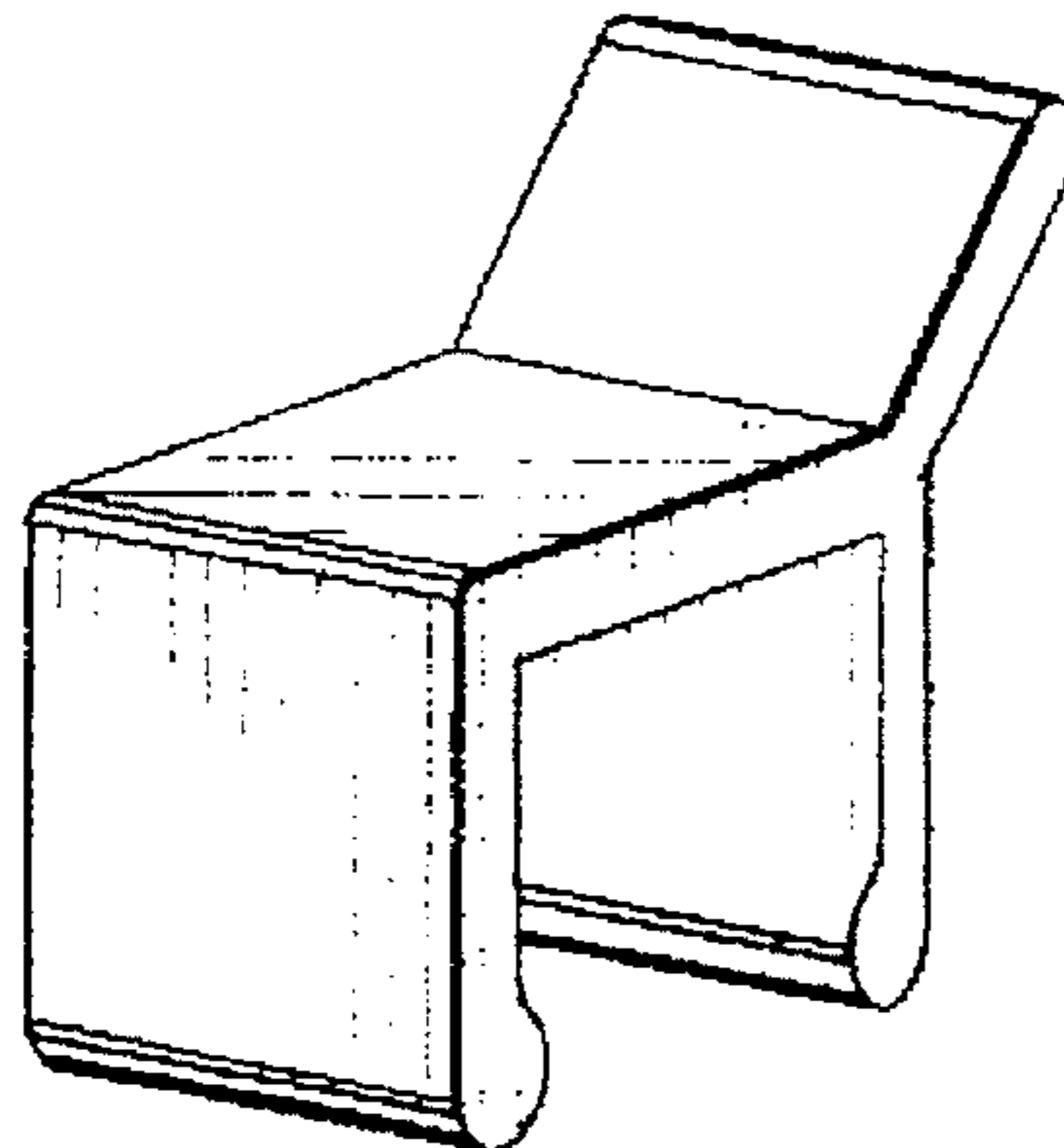

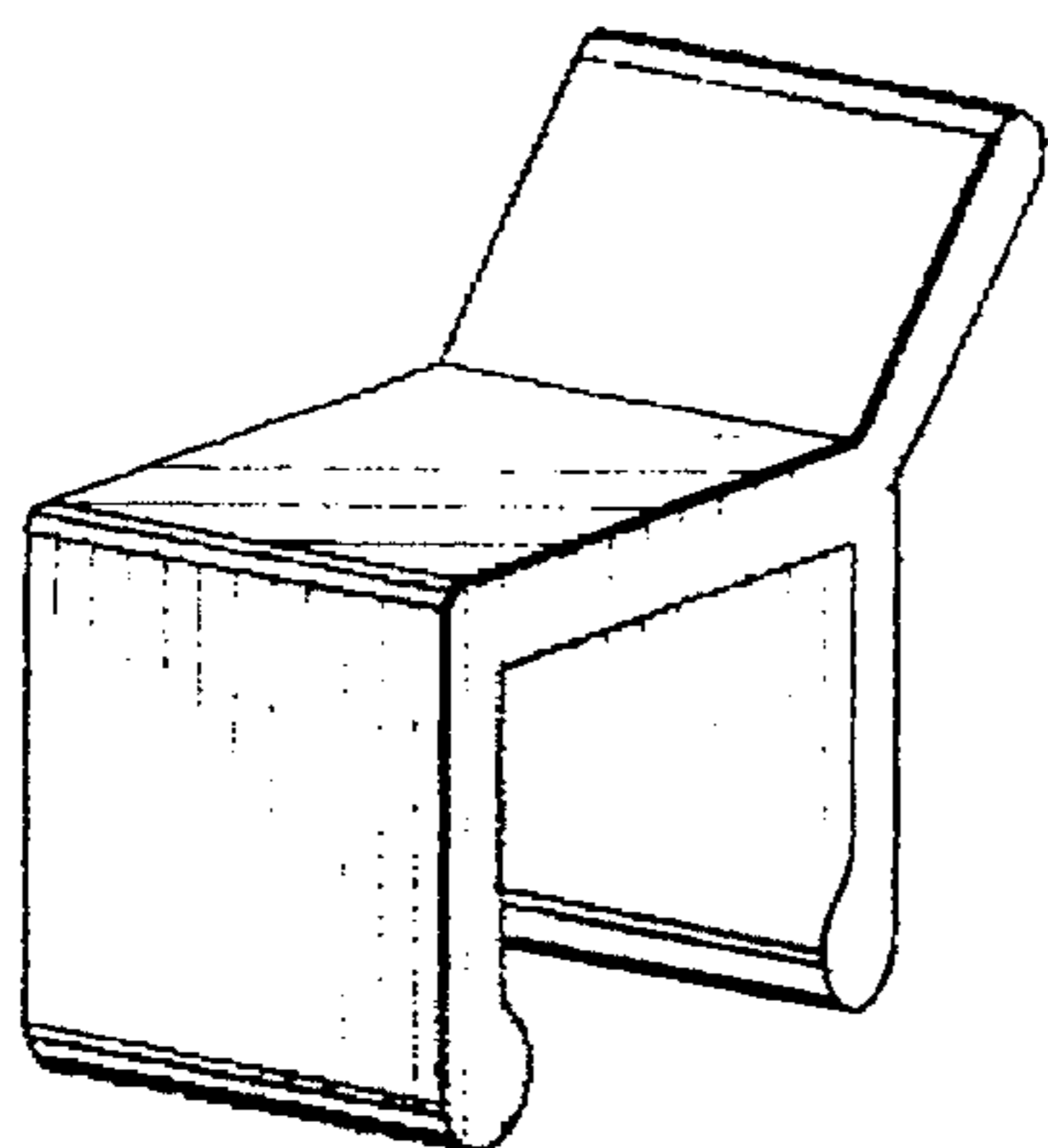

FIG. 1

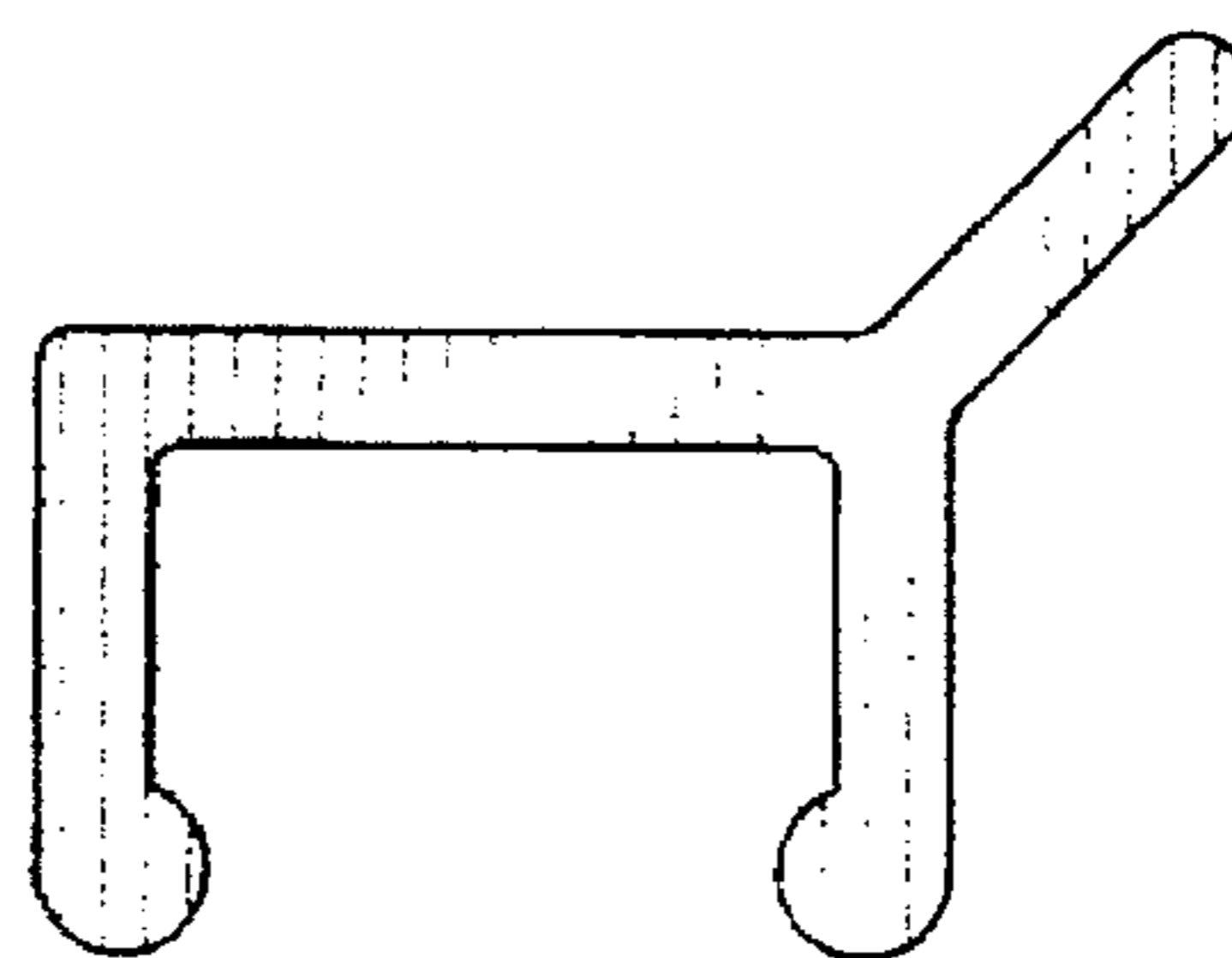

FIG. 3

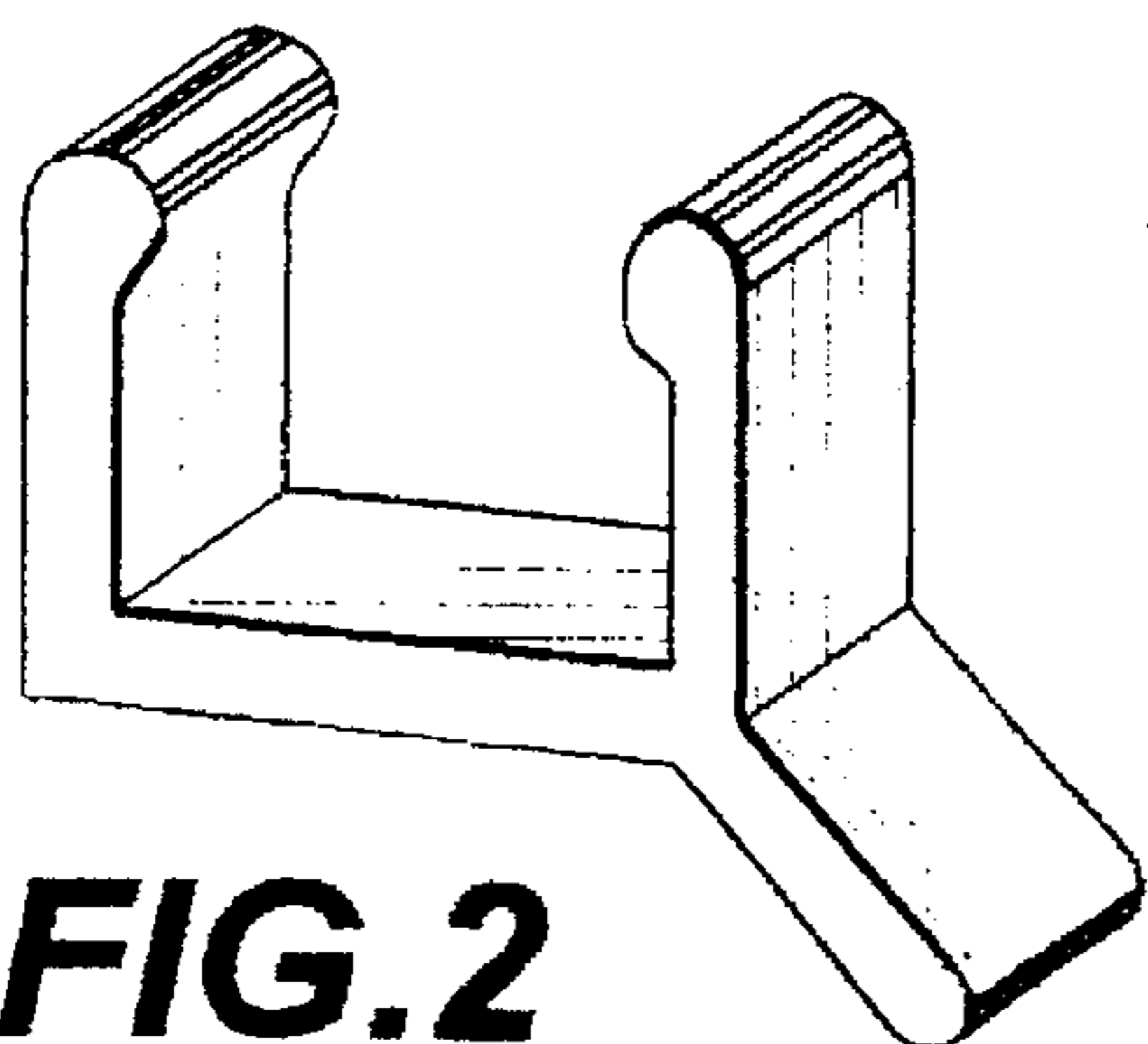

FIG. 2

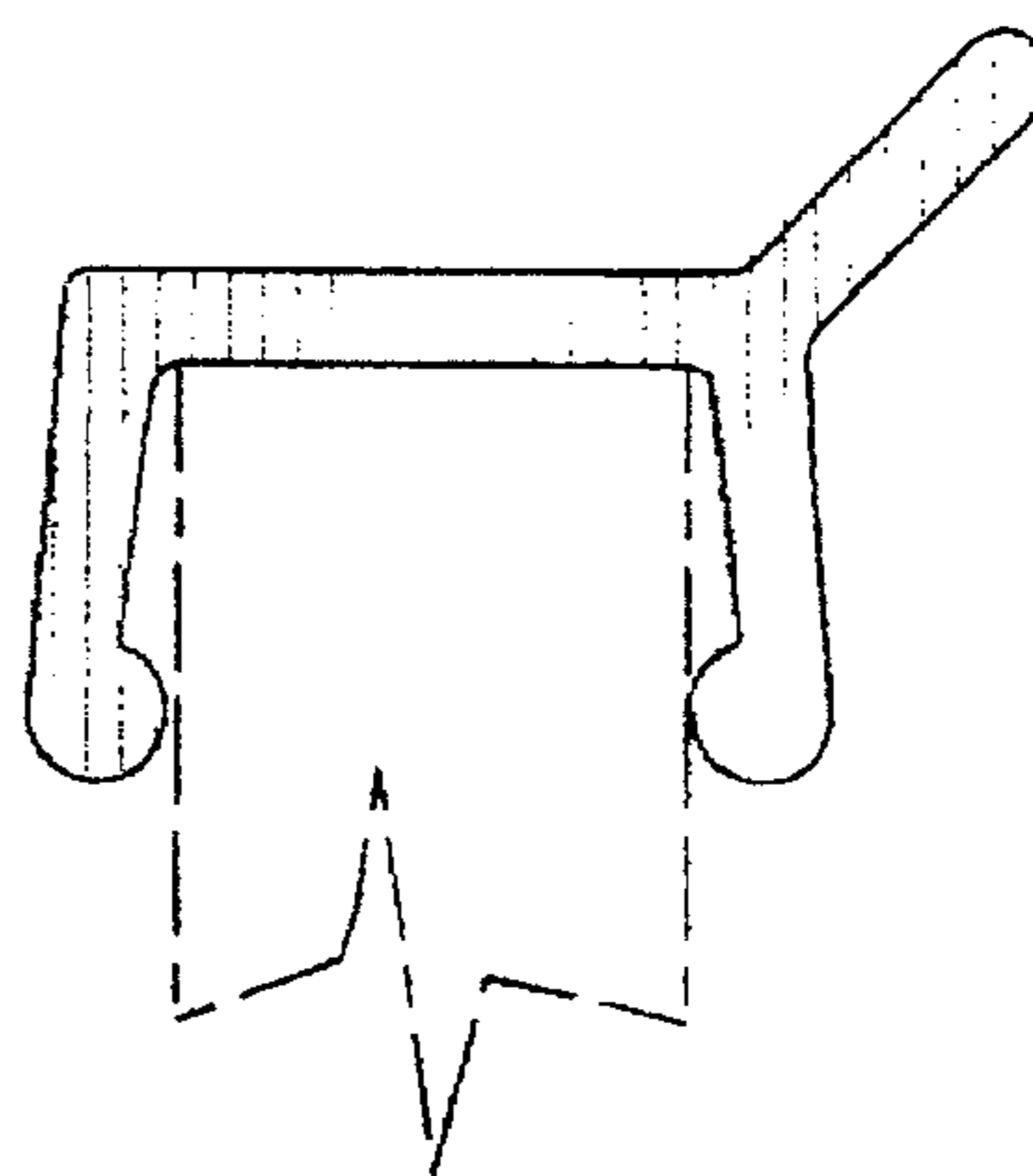

FIG. 4

FIG. 5

