



US00D379020S

United States Patent [19]

Avitan

[11] Patent Number: **Des. 379,020**

[45] Date of Patent: ****Apr. 29, 1997**

[54] **FORK LIFT TRUCK**

[75] Inventor: **Isaac Avitan**, Sioux City, Iowa

[73] Assignee: **Schaeff, Incorporated**, Sioux City, Iowa

[**] Term: **14 Years**

[21] Appl. No.: **38,413**

[22] Filed: **May 5, 1995**

[52] U.S. Cl. **D34/34**

[58] Field of Search **D34/28, 34, 37; 414/785; 187/222, 237, 238; 180/89.12, 89.13, 89.17**

D. 354,604	1/1995	Soederberg	D34/34
D. 358,925	5/1995	Chung et al.	D34/28
3,999,675	12/1976	Forry et al.	187/237

Primary Examiner—A. Hugo Word
Assistant Examiner—Robin V. Taylor
Attorney, Agent, or Firm—Zarley, McKee, Thomte, Voorhees & Sease

[57] CLAIM

The ornamental design for a fork lift truck, as shown.

DESCRIPTION

FIG. 1 is a perspective view of the invention; FIG. 2 is a right side elevational view of the invention; FIG. 3 is a front elevational view of the invention; FIG. 4 is a back elevational view of the invention; FIG. 5 is a top plan view of the invention; and, FIG. 6 is a left side elevational view of the invention.

[56] References Cited

U.S. PATENT DOCUMENTS

Re. 30,815	12/1981	Kelley	187/238
D. 222,694	12/1971	Goodacre	D34/34
D. 353,931	12/1994	Kobayakawa et al.	D34/34

1 Claim, 3 Drawing Sheets

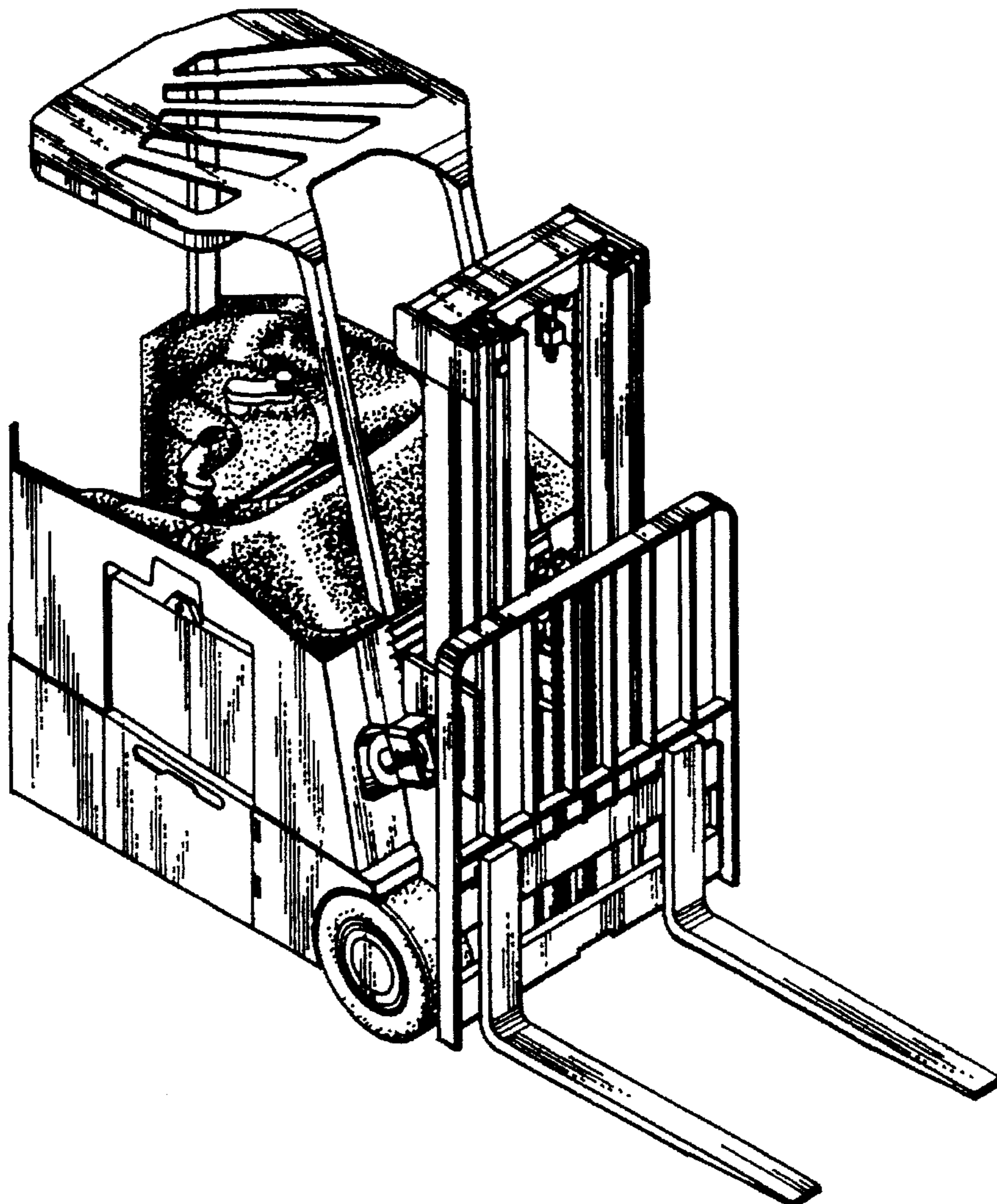

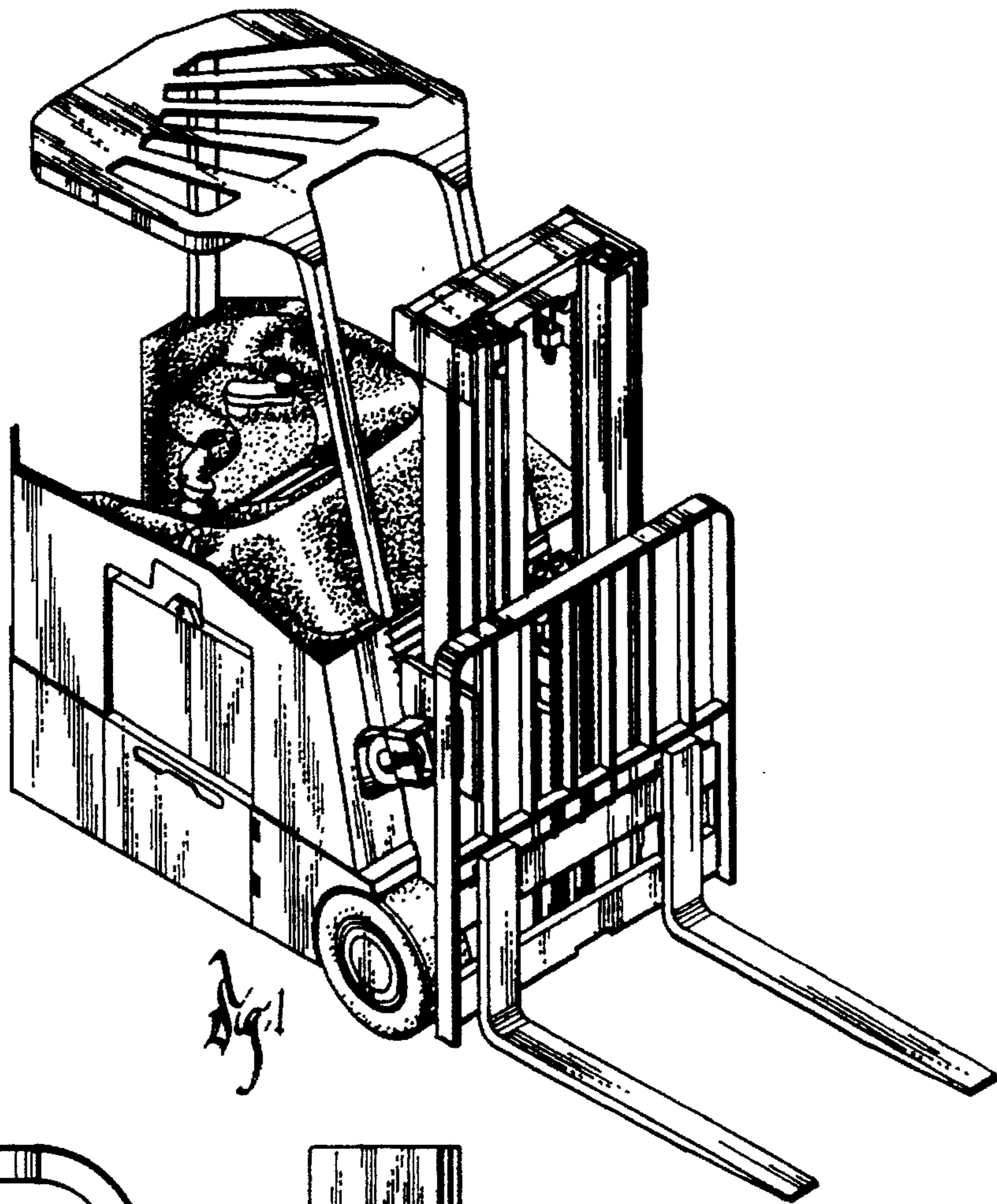

Fig. 1

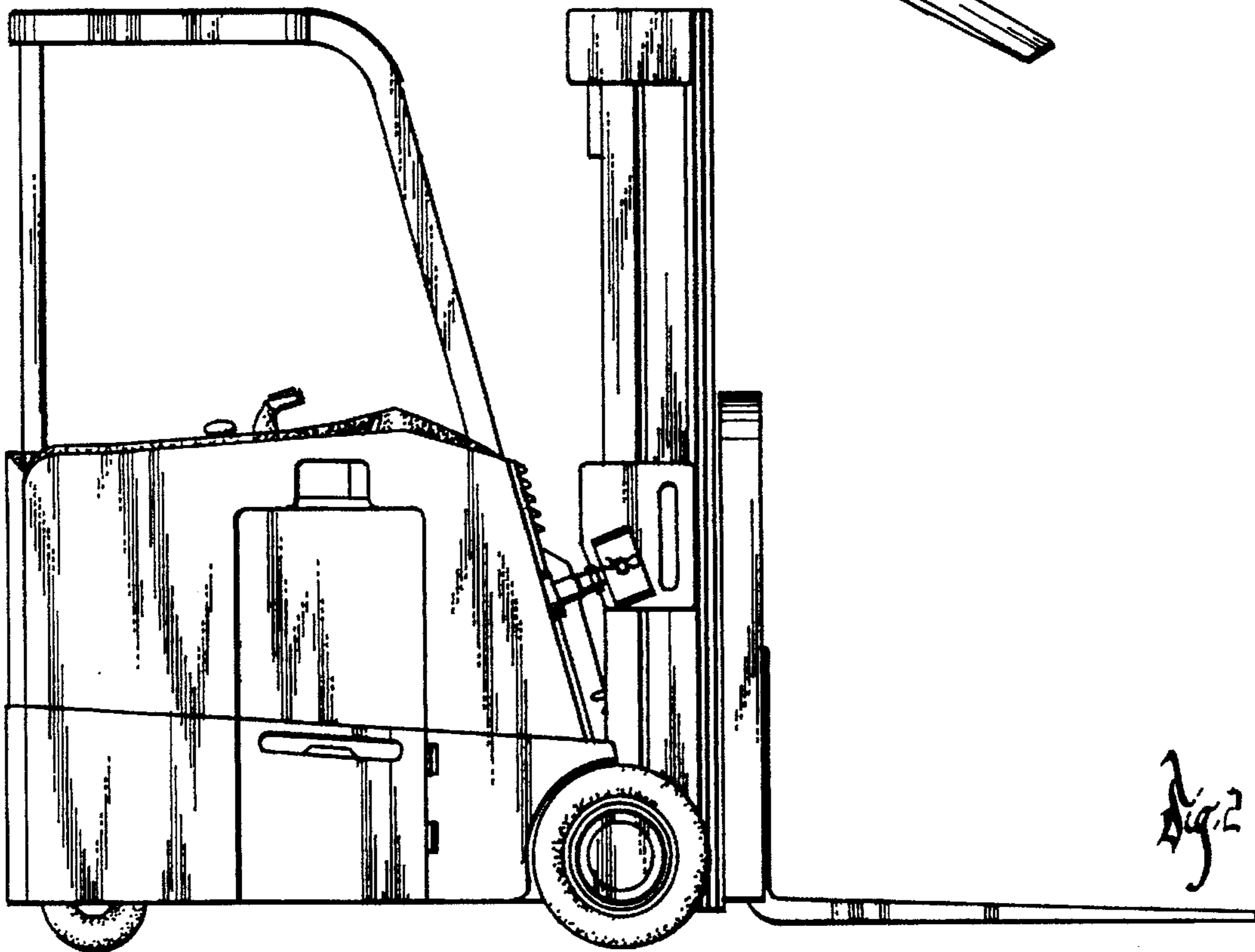
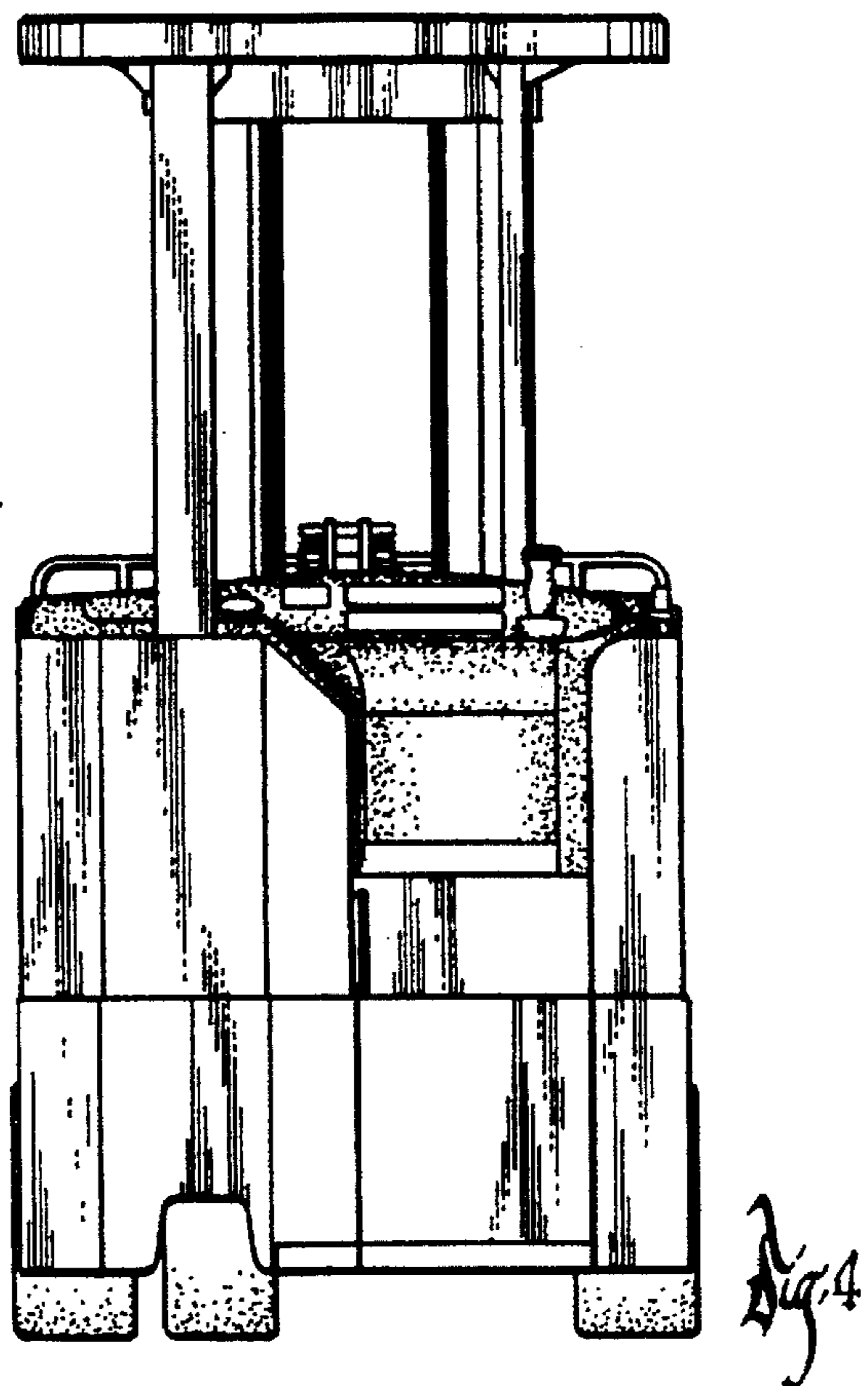
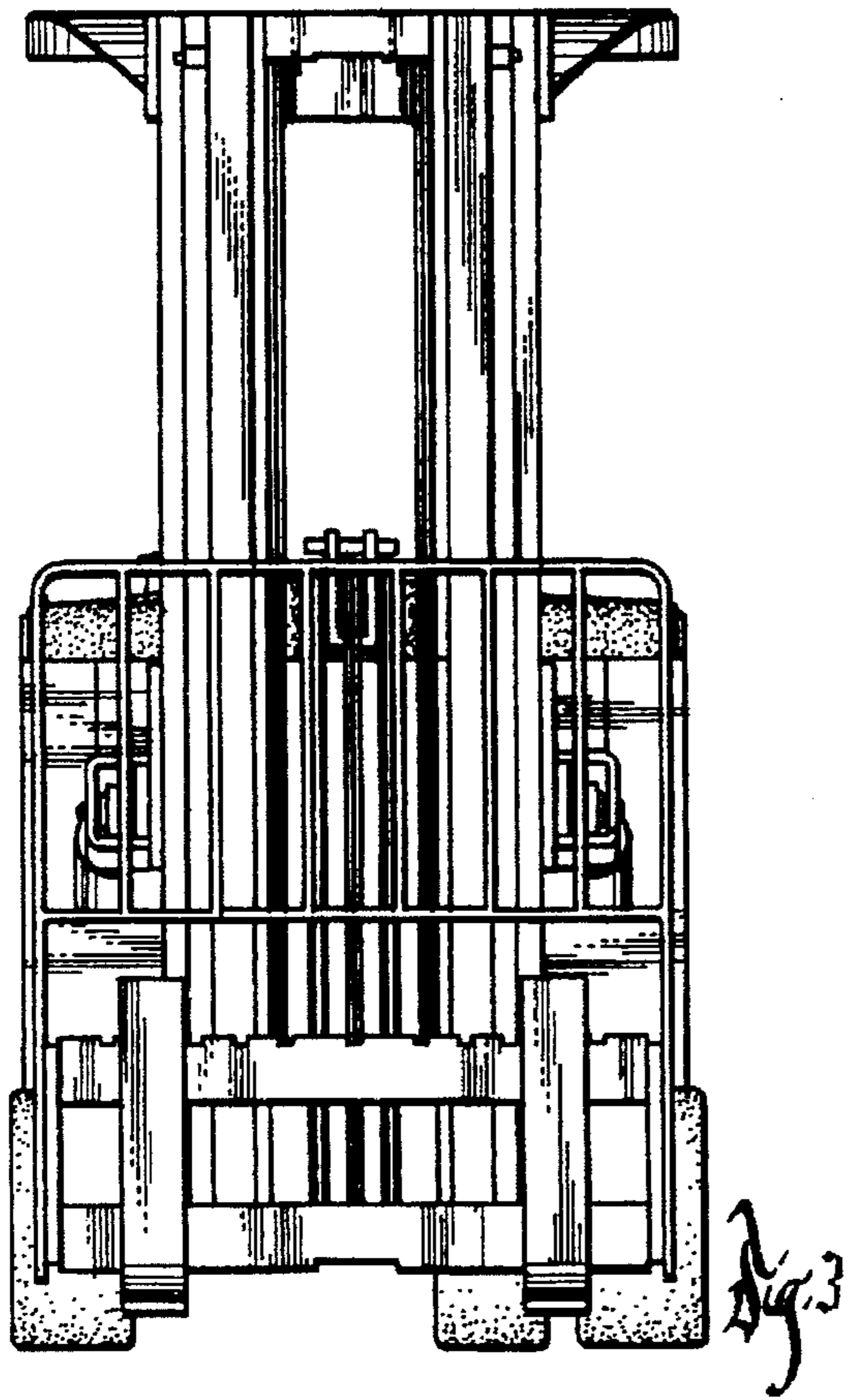

Fig. 2



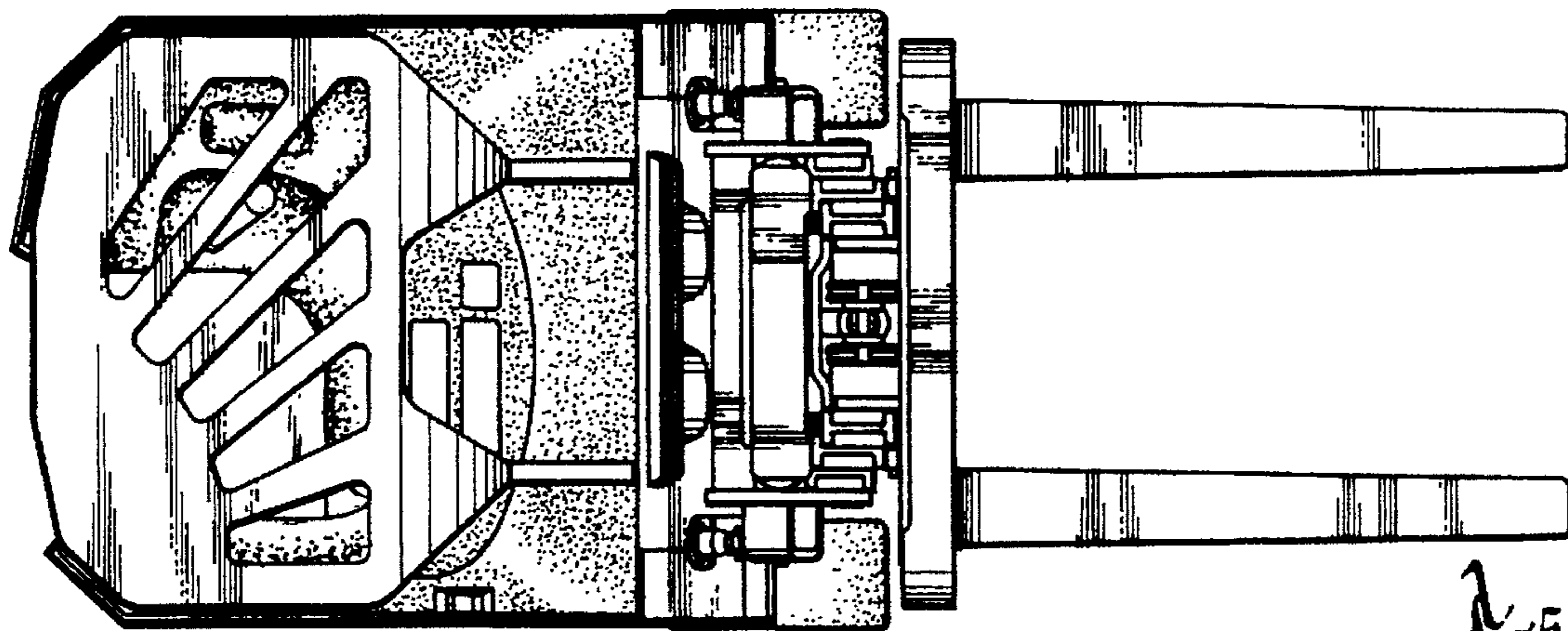

Fig. 5

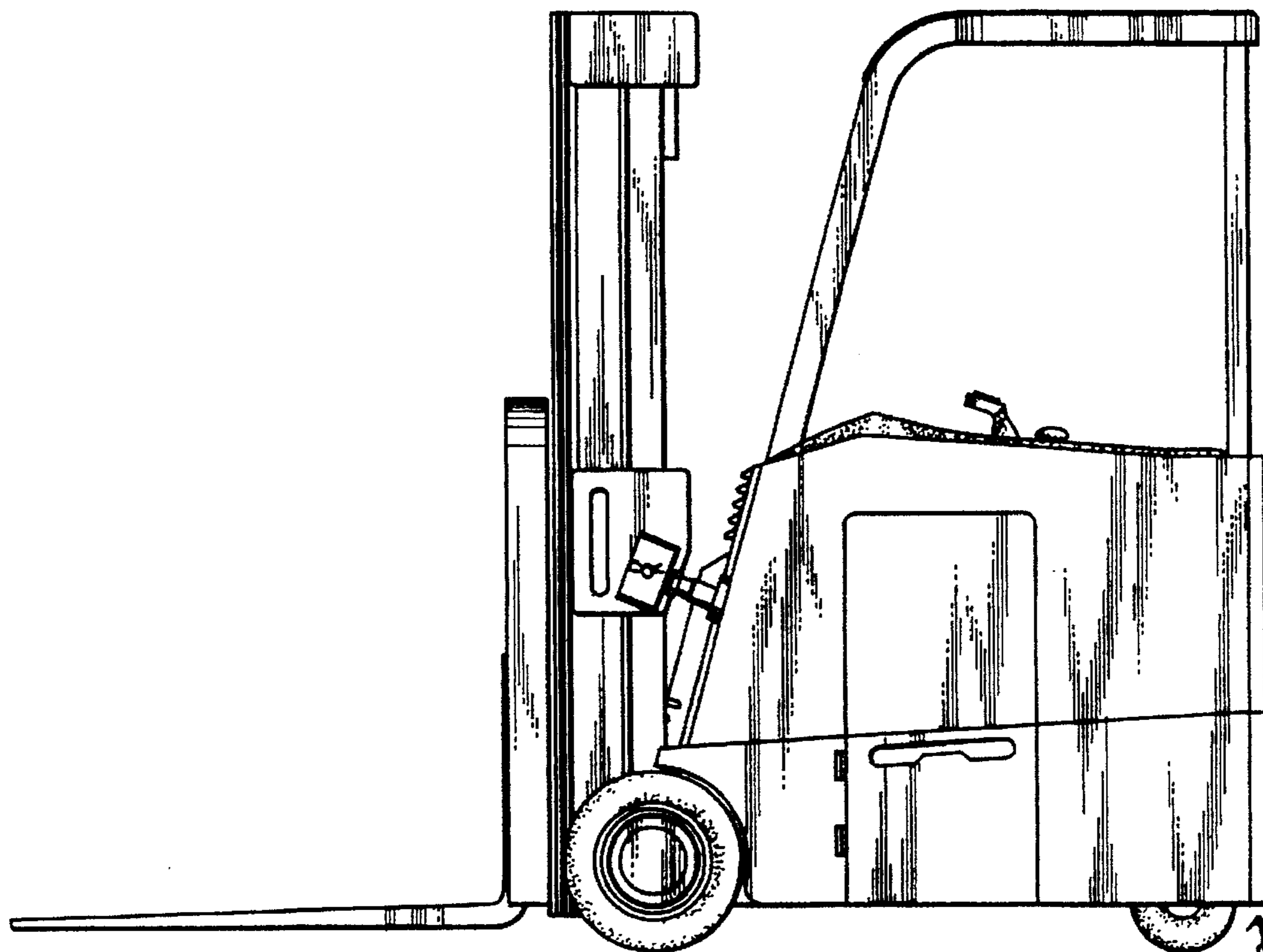

Fig. 6