



US00D379017S

# United States Patent [19] Chapman

[11] Patent Number: **Des. 379,017**  
[45] Date of Patent: **\*\*Apr. 29, 1997**

- [54] CAMERA CRANE ARM BASE
- [75] Inventor: **Leonard T. Chapman**, North Hollywood, Calif.
- [73] Assignee: **Leonard Studio Equipment, Inc.**, North Hollywood, Calif.
- [\*\*] Term: **14 Years**
- [21] Appl. No.: **42,114**
- [22] Filed: **Aug. 1, 1995**
- [52] U.S. Cl. .... **D34/28**
- [58] Field of Search ..... D34/23, 28, 33, D34/35, 36; 280/47.11, 47.33; 354/293; 212/294-5, 901; 182/2, 152; 254/45, 2 C, 10 R, 8 R, 124

5,312,121 5/1994 Chapman .  
5,318,313 6/1994 Chapman ..... 280/47.11

### OTHER PUBLICATIONS

The HY HY Crane Arm Base brochure, Leonard Studio Equipment, Inc. (1993).

*Primary Examiner*—A. Hugo Word  
*Assistant Examiner*—Robin V. Taylor  
*Attorney, Agent, or Firm*—Lyon & Lyon

### [57] CLAIM

The ornamental design for a camera crane arm base, as shown and described.

### DESCRIPTION

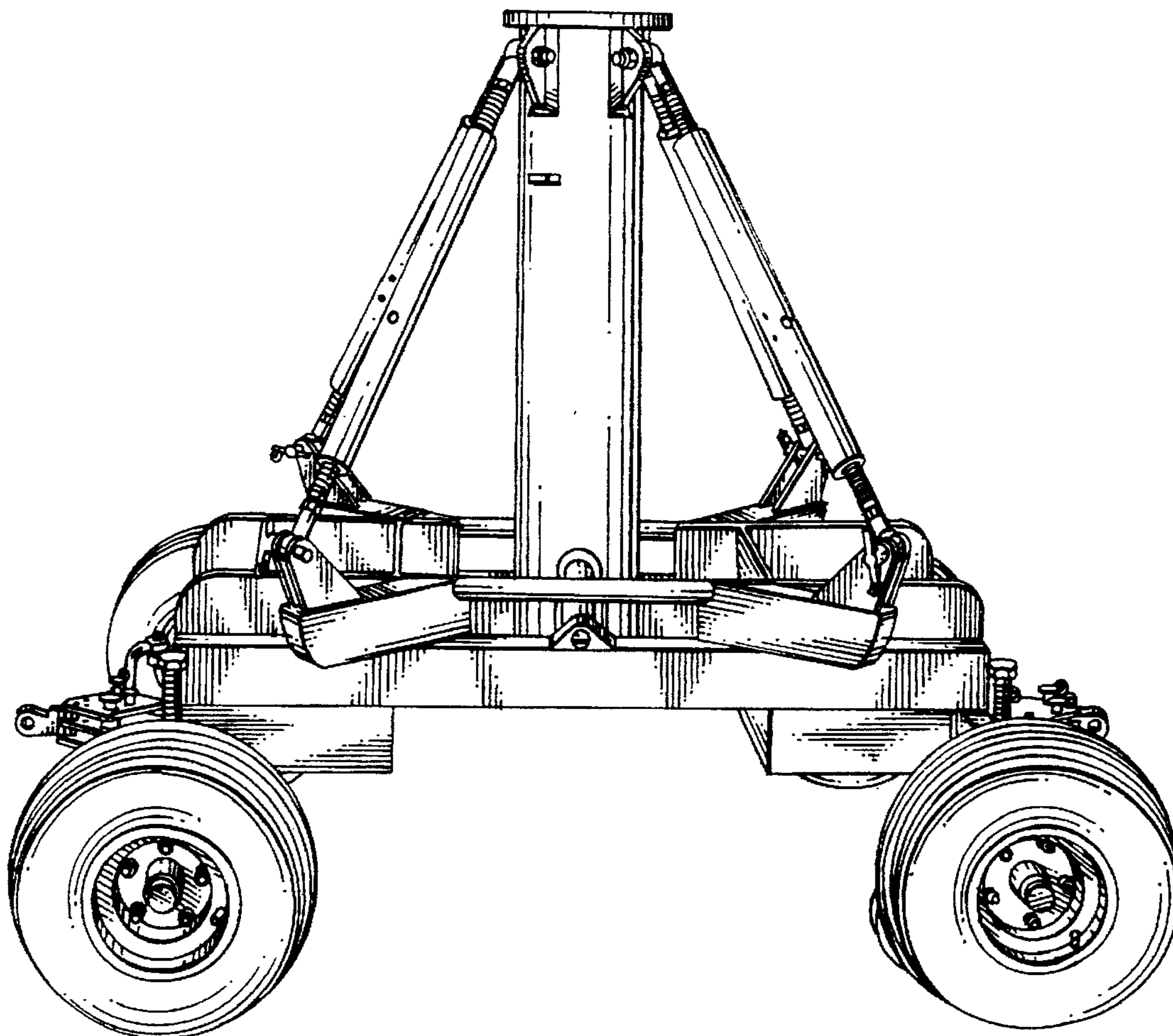
FIG. 1 is a left side elevation view showing my design, and the right side view thereof being the same as the left side view;  
FIG. 2 is an end view thereof, the oppoiste end thereof being the same;  
FIG. 3 is a bottom view thereof;  
FIG. 4 is a top and left side view thereof; and,  
FIG. 5 is a top view thereof.

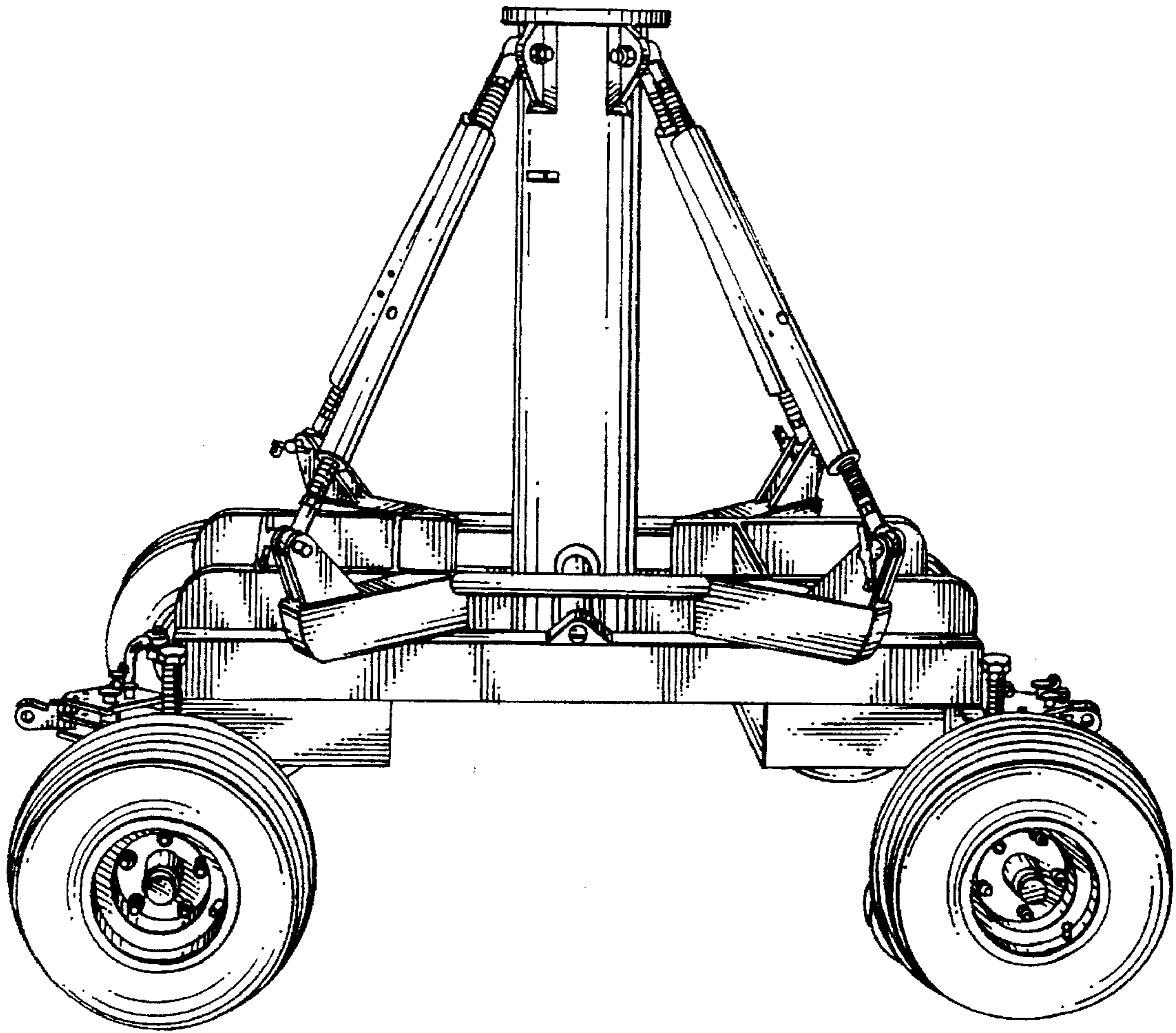
### [56] References Cited

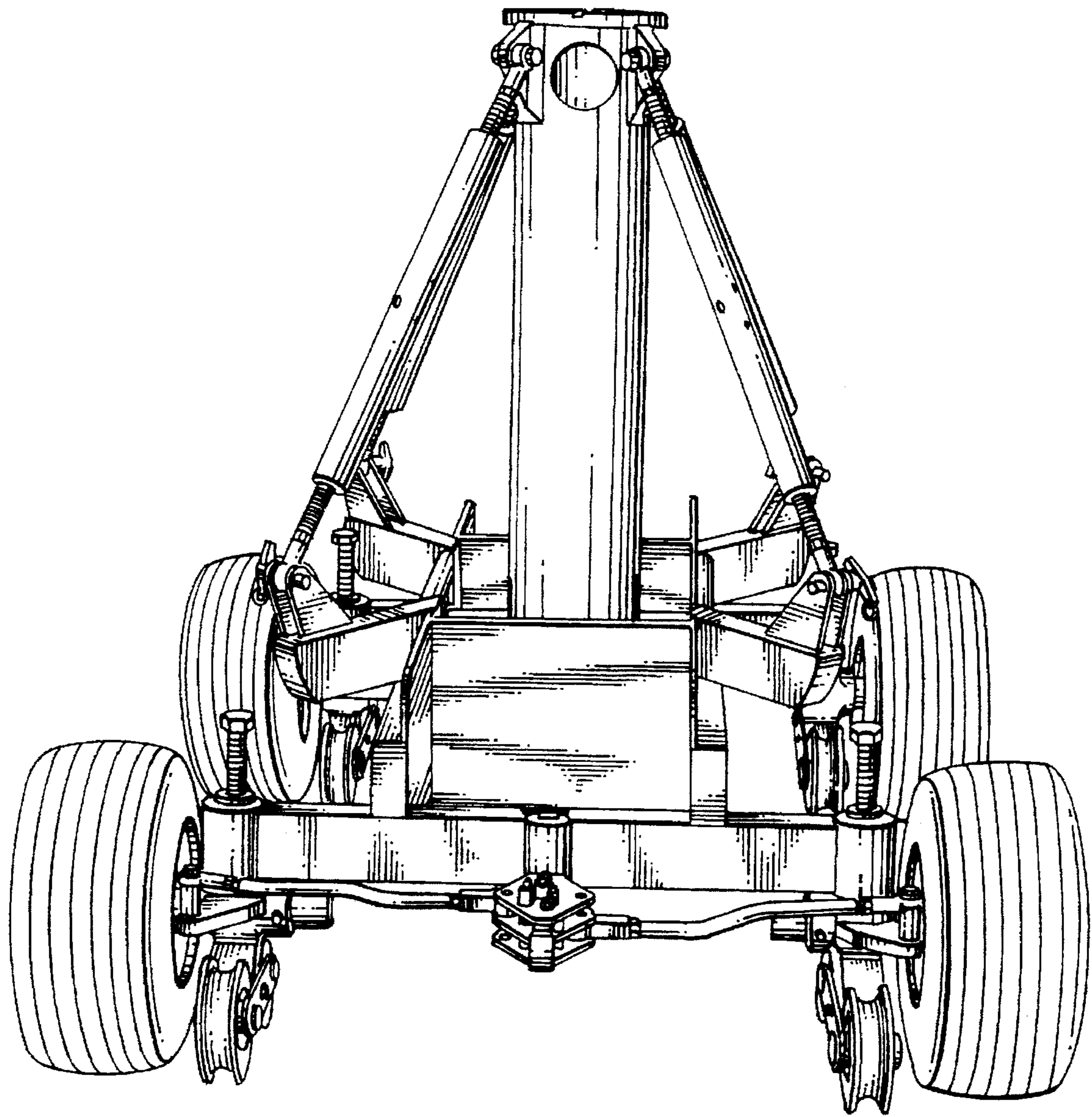
#### U.S. PATENT DOCUMENTS

D. 348,340	6/1994	Collins et al. ....	D34/28
4,095,250	6/1978	Giglioli .....	280/47.11
4,597,498	7/1986	Spinosa .....	121/901
4,899,097	2/1990	Chapman .....	182/2
4,907,768	3/1990	Masseron .....	D34/33

**1 Claim, 5 Drawing Sheets**

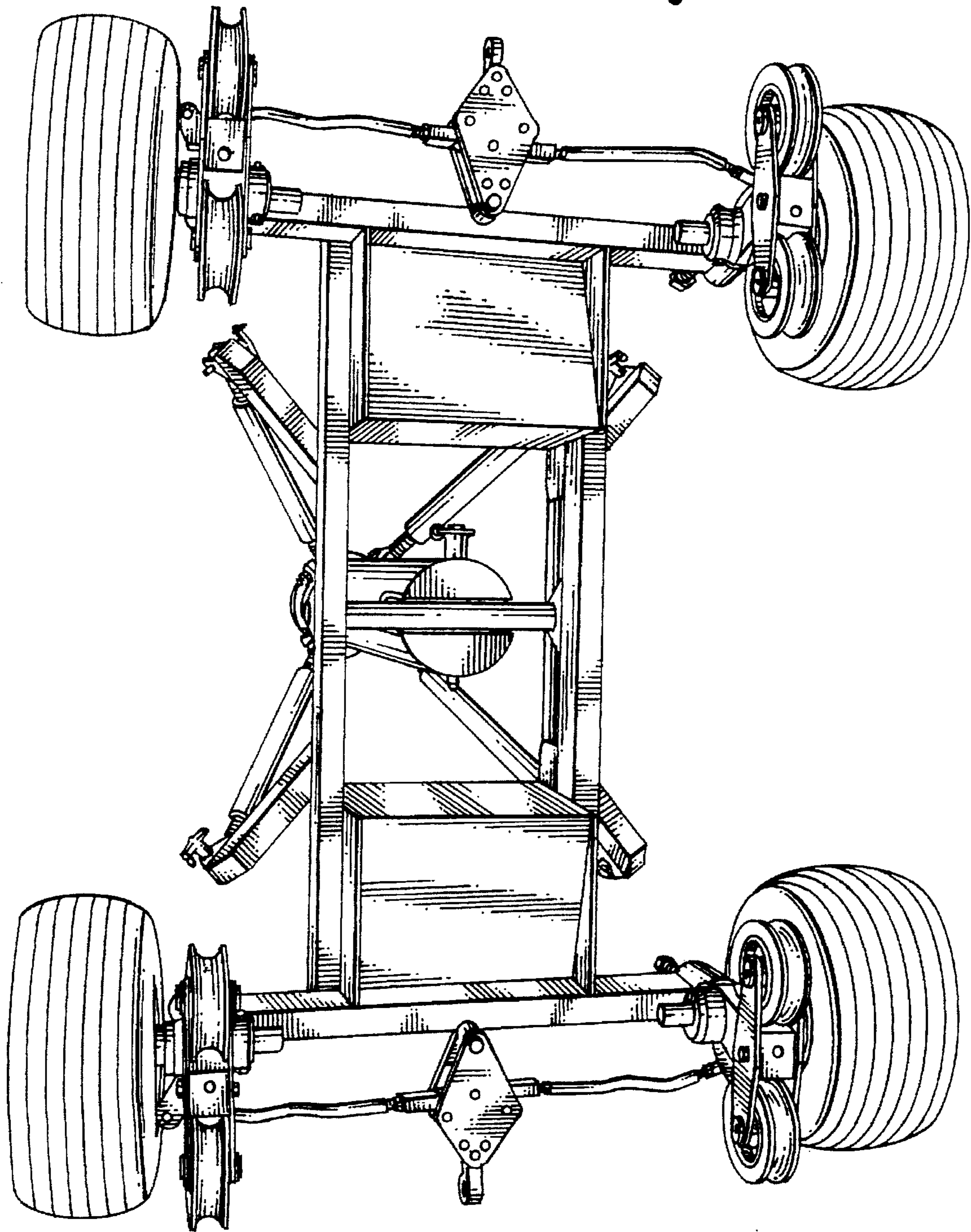


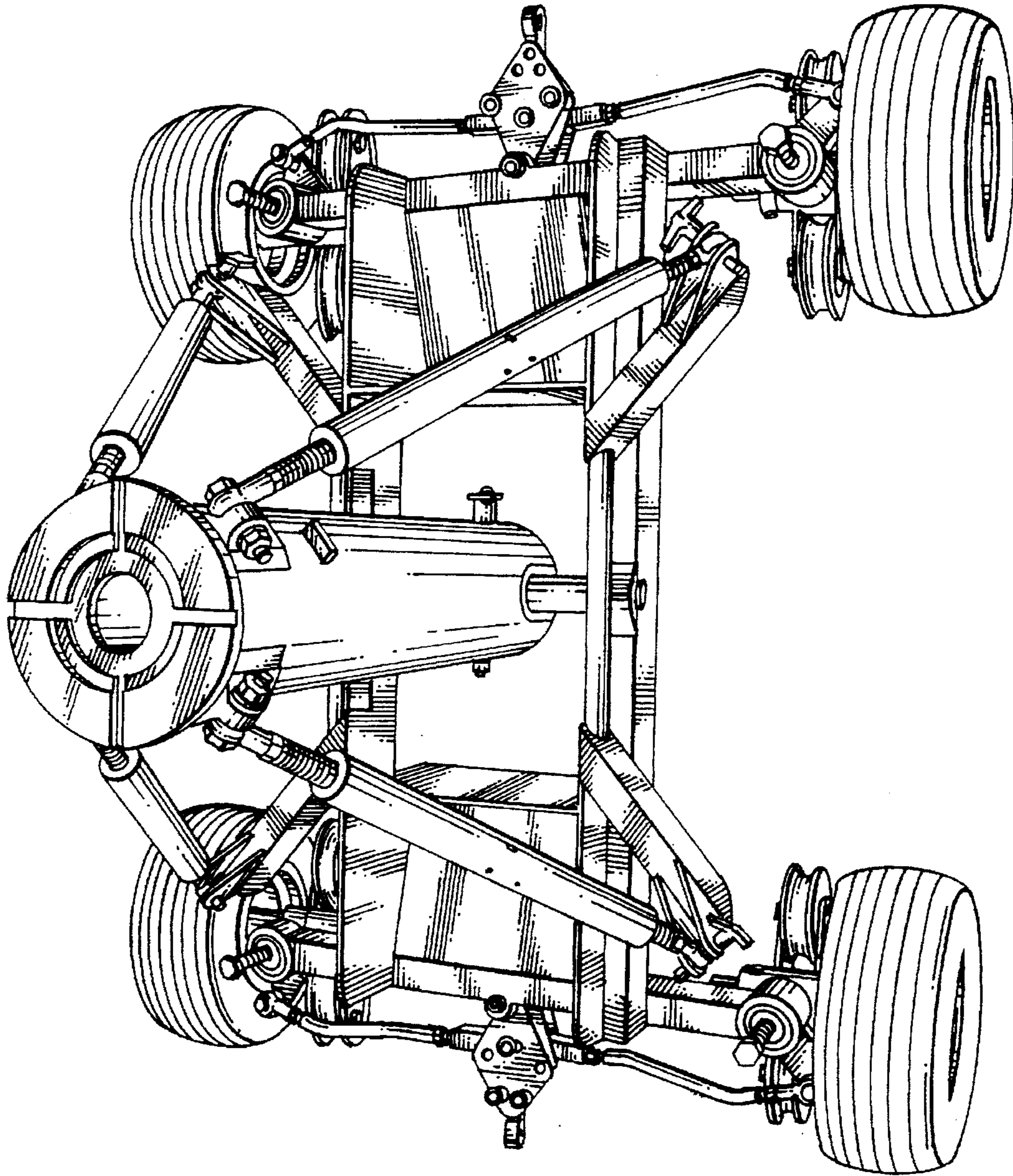




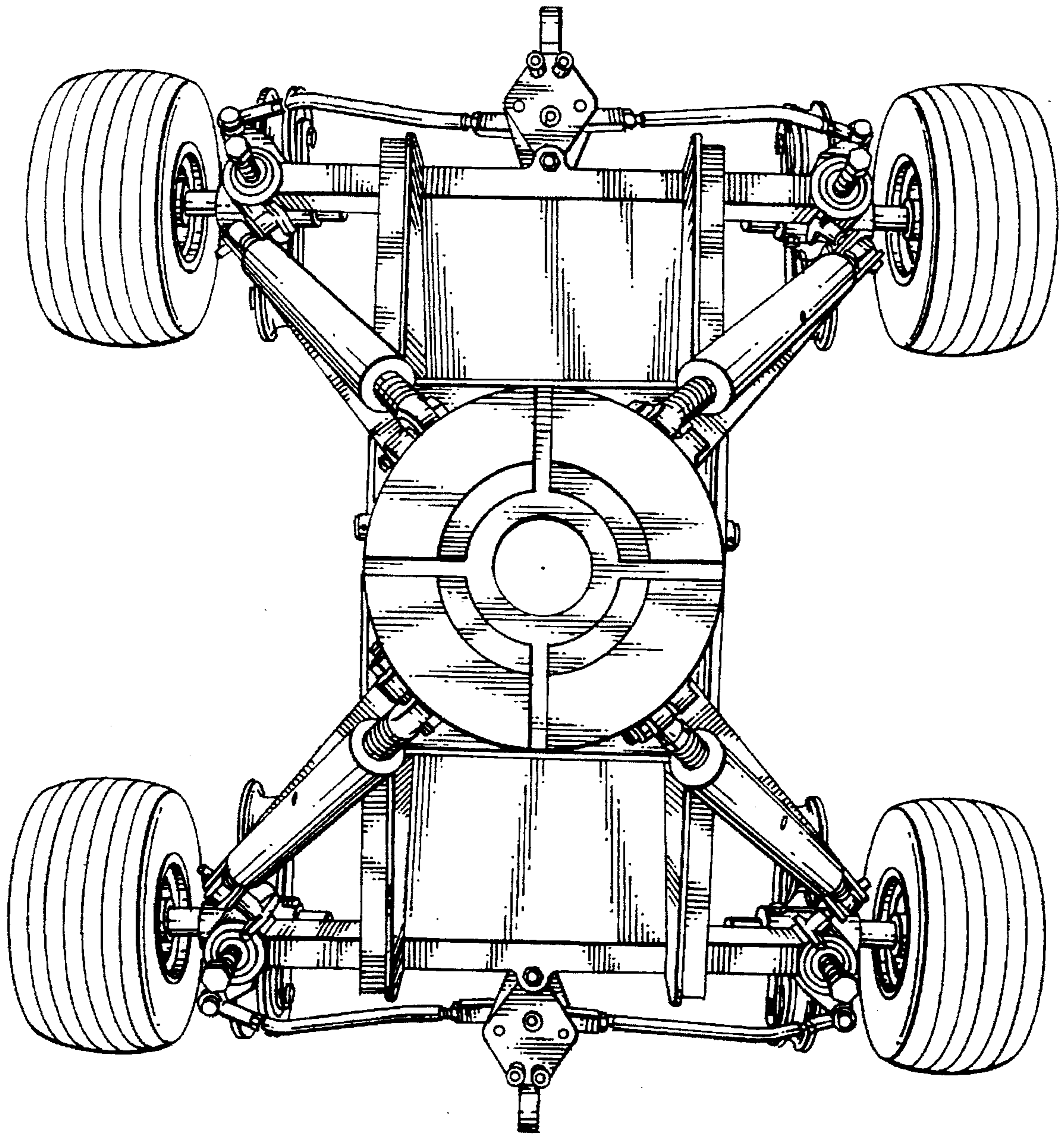
**Fig. 2**

*Fig. 3*





**Fig. 4**



**Fig. 5**