



US00D378994S

United States Patent [19]

Picard et al.

[11] Patent Number: **Des. 378,994**

[45] Date of Patent: ****Apr. 29, 1997**

[54] NEIGHBORHOOD ELECTRIC VEHICLE

[75] Inventors: **Claude Picard; Francois Trepanier; Mario Coulombe**, all of Rock-Forest; **Sylvain Poulin**, Valcourt, all of Canada

[73] Assignee: **Bombardier Inc.**, Montreal, Canada

[**] Term: **14 Years**

[21] Appl. No.: **41,524**

[22] Filed: **Jul. 17, 1995**

[52] U.S. Cl. **D12/90**

[58] Field of Search D12/85, 86, 90-92; 296/183-185

[56] References Cited

U.S. PATENT DOCUMENTS

D. 298,521	11/1988	Ui et al.	D12/91
D. 346,990	5/1994	Abbott et al.	D12/91
D. 371,526	7/1996	Verduyn et al. . .	D12/86

OTHER PUBLICATIONS

Motor Trend, Jun. 1995, p. 61, the Volkswagen GTI VR6 car.

Primary Examiner—Melody N. Brown
Attorney, Agent, or Firm—St. Onge Steward Johnston & Reens

[57] CLAIM

The ornamental design for a neighborhood electric vehicle, as shown.

DESCRIPTION

FIG. 1 is a perspective view, showing our new design for a neighborhood electric vehicle;
FIG. 2 is a front elevation view, showing our new design;
FIG. 3 is a side elevational view, showing our new design;
FIG. 4 is a rear elevational view, showing our new design; and,
FIG. 5 is a top plan view, showing our new design.

1 Claim, 5 Drawing Sheets

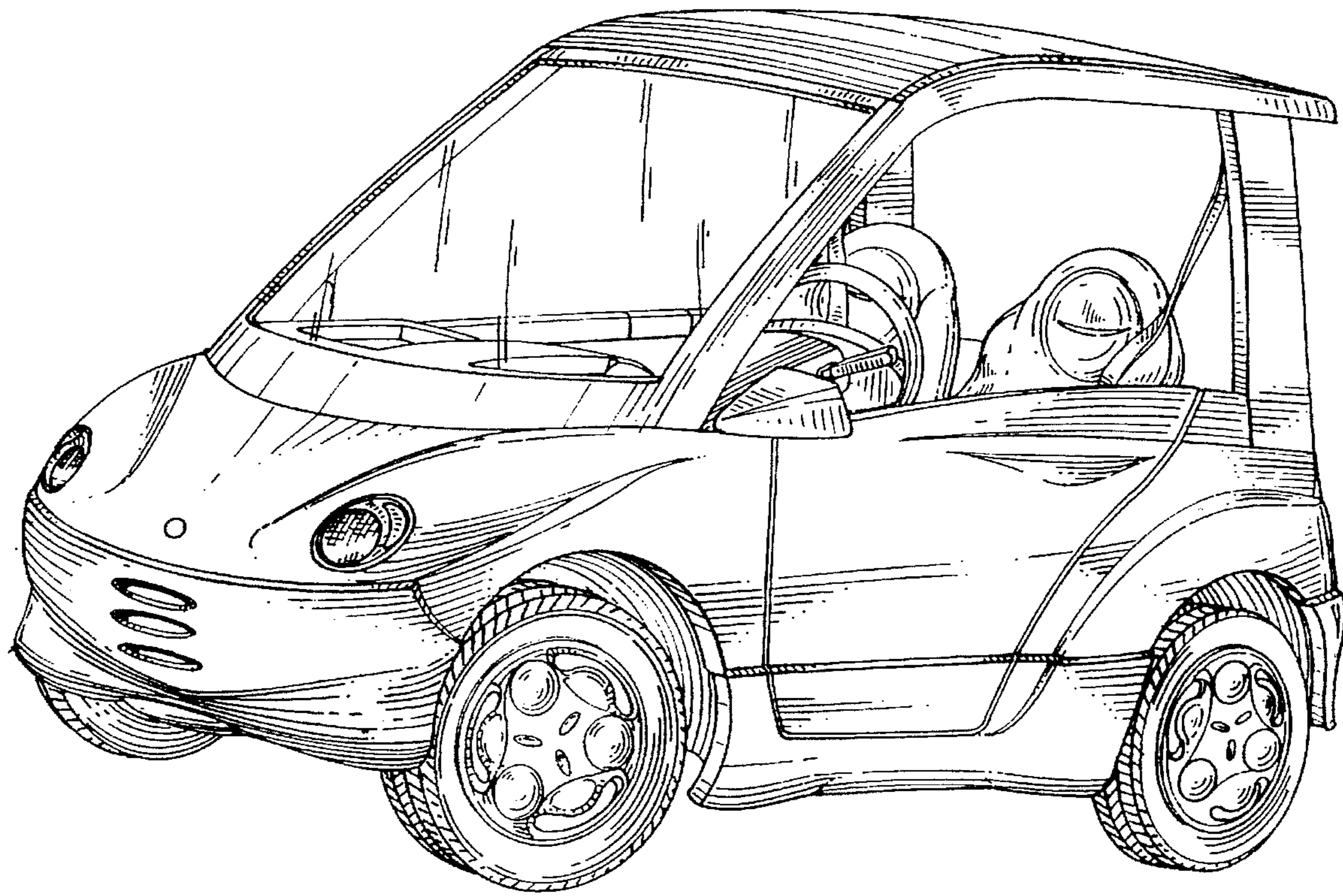

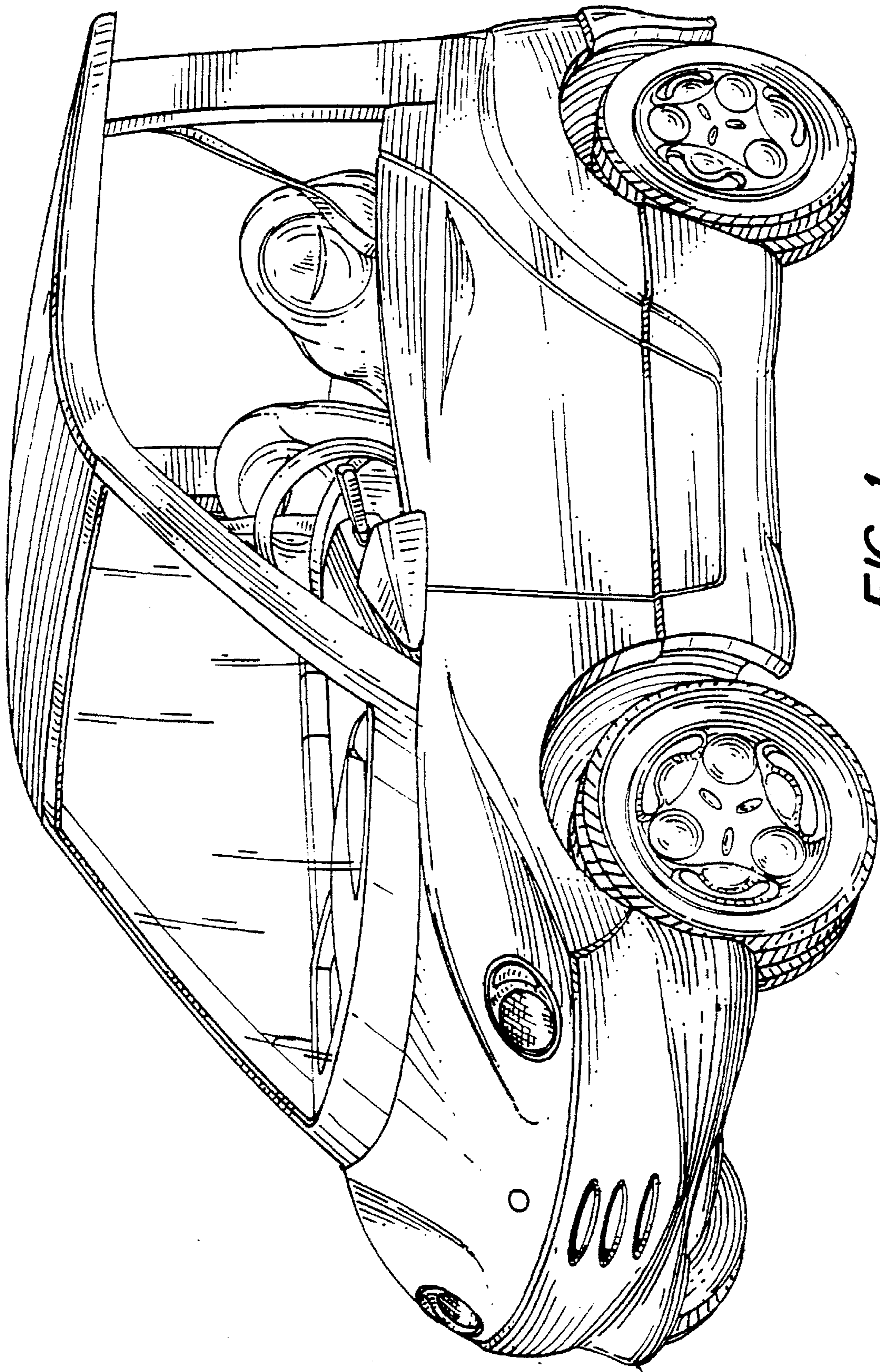

FIG. 1

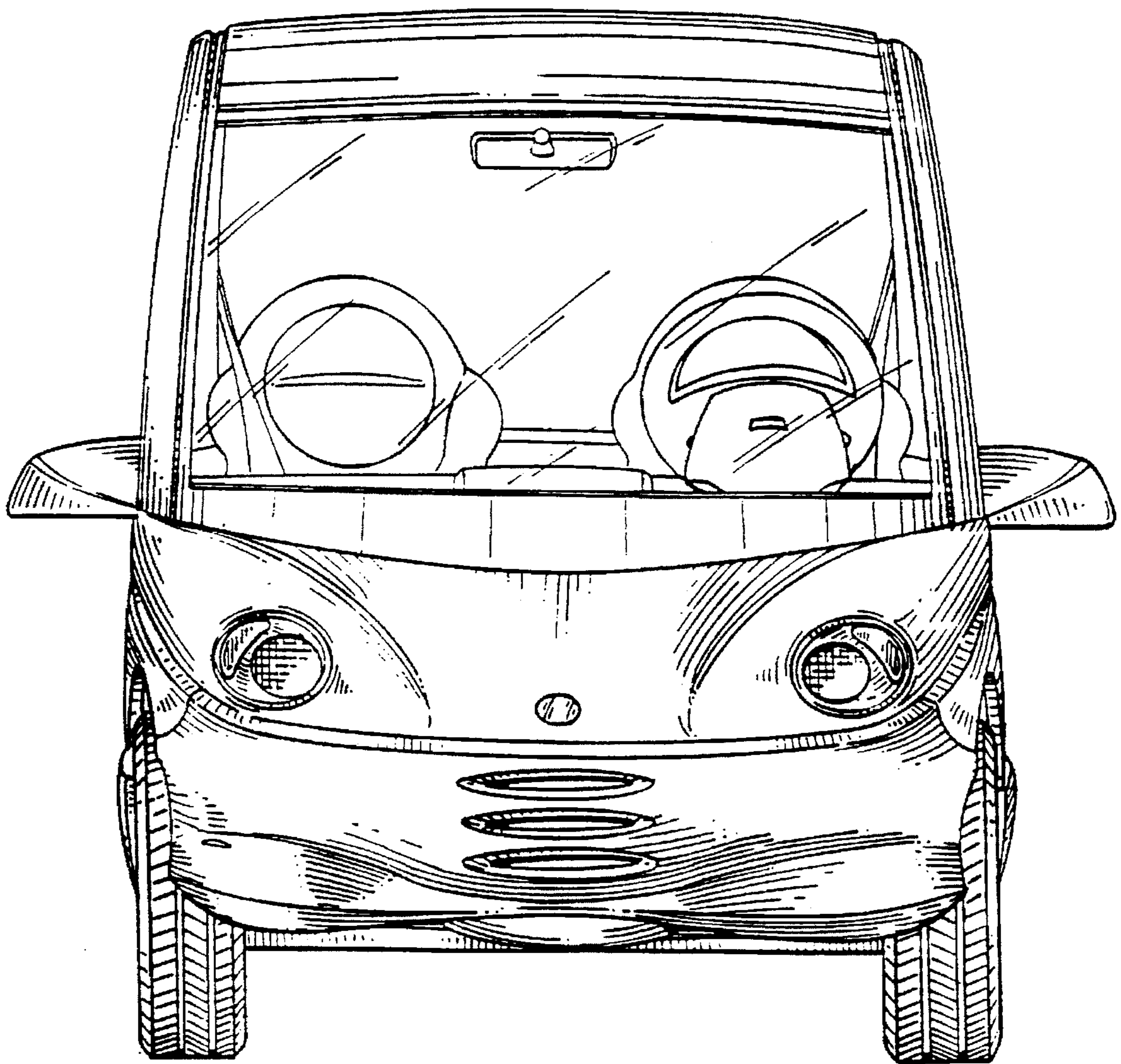

FIG. 2

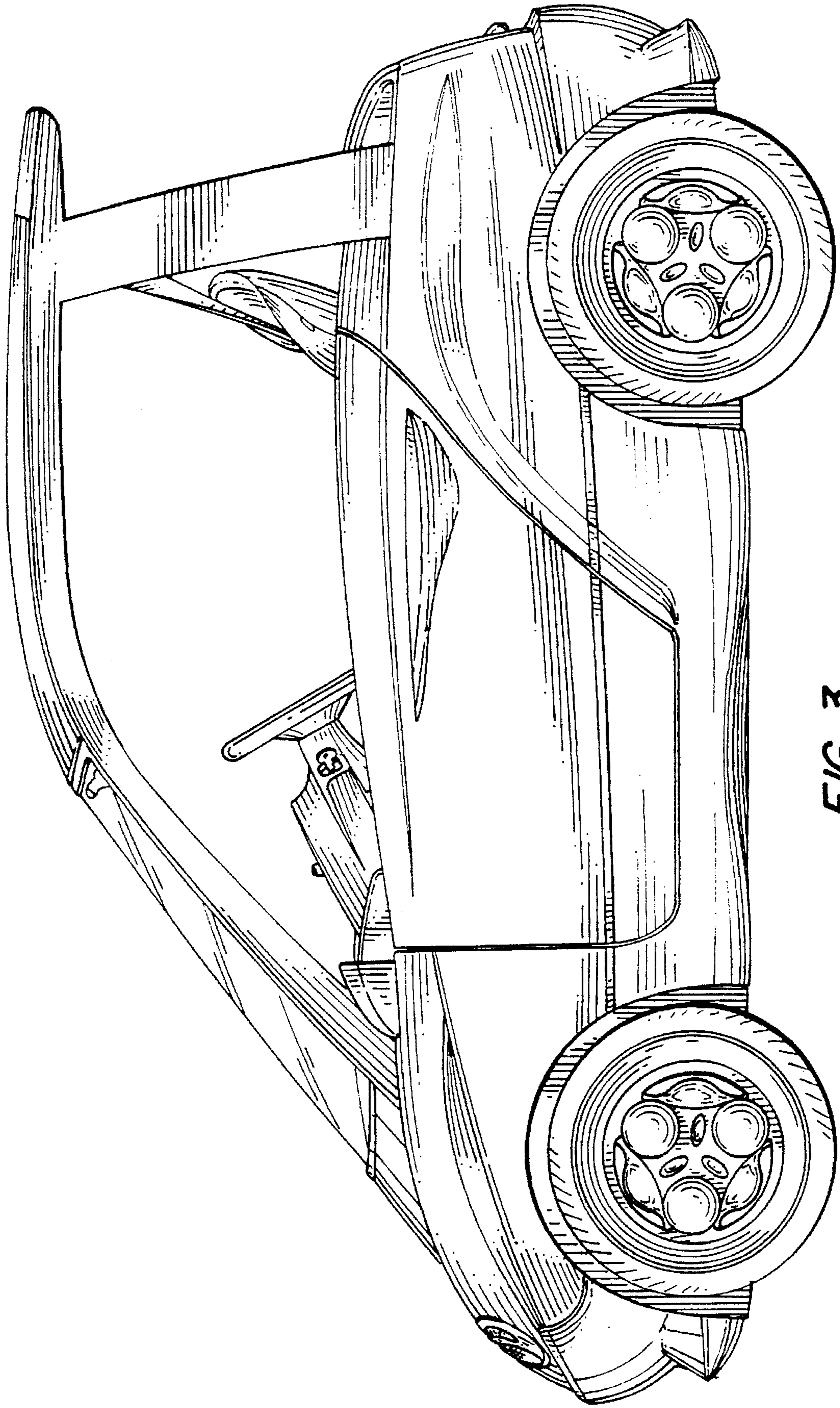

FIG. 3

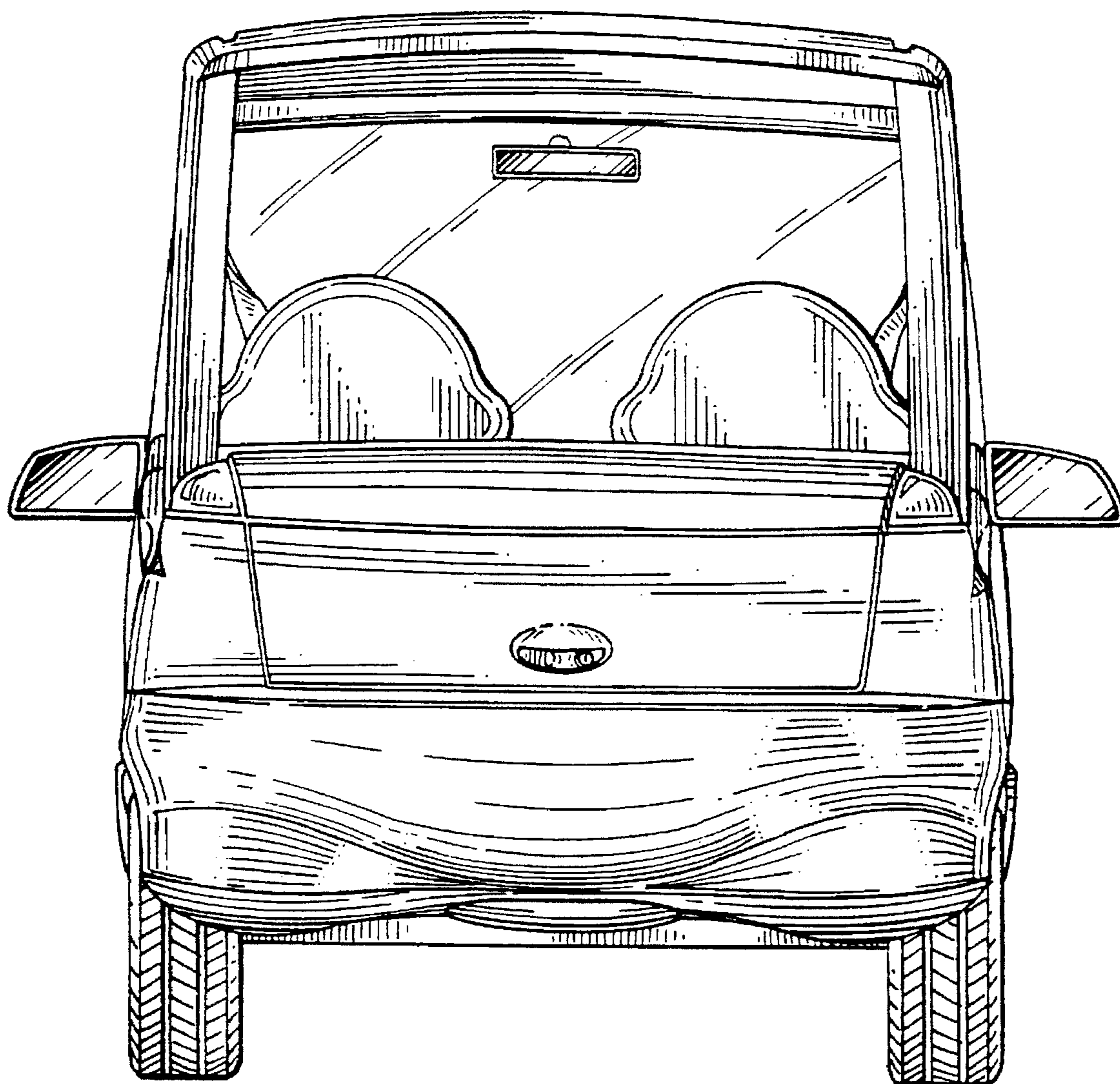

FIG. 4

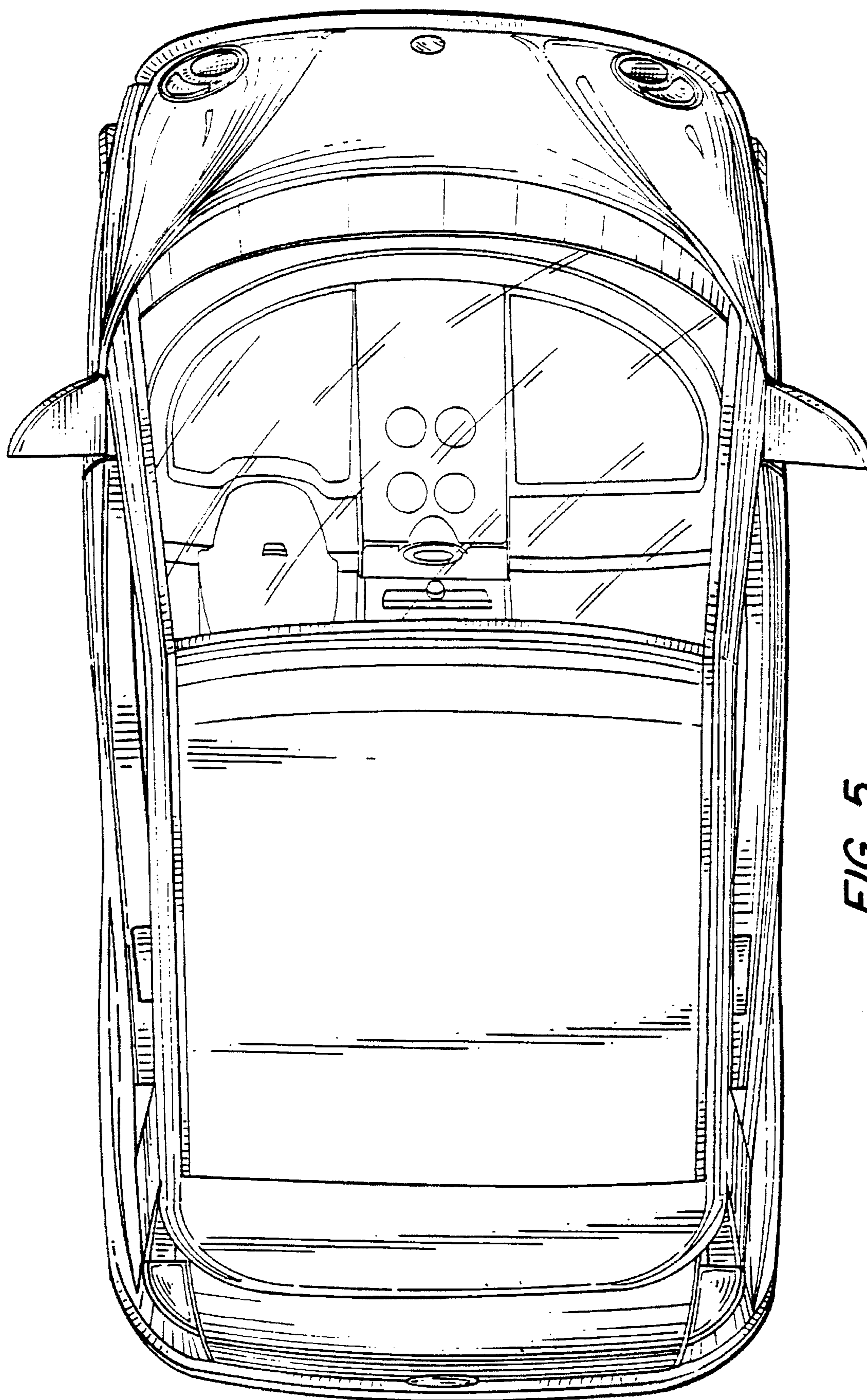

FIG. 5