



US00D378905S

United States Patent [19]

Meister et al.

[11] Patent Number: **Des. 378,905**

[45] Date of Patent: ****Apr. 22, 1997**

[54] **TOWED PERSONNEL TRANSPORT**

[75] Inventors: **Michael L. Meister; Keith A. Pfannenstiel**, both of Wichita, Kans.

[73] Assignee: **Chance Industries, Inc.**, Wichita, Kans.

[**] Term: **14 Years**

[21] Appl. No.: **46,959**

[22] Filed: **Nov. 22, 1995**

[52] U.S. Cl. **D12/84**

[58] Field of Search **D12/84, 83, 40; D9/308; D21/129; 296/178**

[56] **References Cited**

U.S. PATENT DOCUMENTS

D. 291,672	9/1987	McFadden	D12/40
D. 291,673	9/1987	McFadden	D12/84
D. 337,517	7/1993	Hwang	D12/40
D. 363,258	10/1995	Calce	D12/84

OTHER PUBLICATIONS

Amusement Rides & Parts Services Brochure, dated Oct. 12, 1995.

Leisure Management, 4000 Series Ultra-Tram advertisement, p. 68, dated Mar. 1995.

Cable Car Concepts, Deltona, Florida, "Trackless Trolley Trams Brochure", dated 1993.

Primary Examiner—A. Hugo Word

Assistant Examiner—Melody N. Brown

Attorney, Agent, or Firm—Shook, Hardy & Bacon L.L.P.

[57] **CLAIM**

The ornamental design for a towed personnel transport, as shown and described.

DESCRIPTION

FIG. 1 is a top perspective view of a towed personnel transport showing our new design; the wheels for which being shown in phantom lines;

FIG. 2 is a front elevation view of the towed personnel transport shown in FIG. 1;

FIG. 3 is a rear elevation view of the towed personnel transport shown in FIG. 1;

FIG. 4 is a side elevation view of one side of the towed personnel transport shown in FIG. 1, the other side being a mirror image thereof; and,

FIG. 5 is a top plan view of the towed personnel transport shown in FIG. 1.

1 Claim, 2 Drawing Sheets

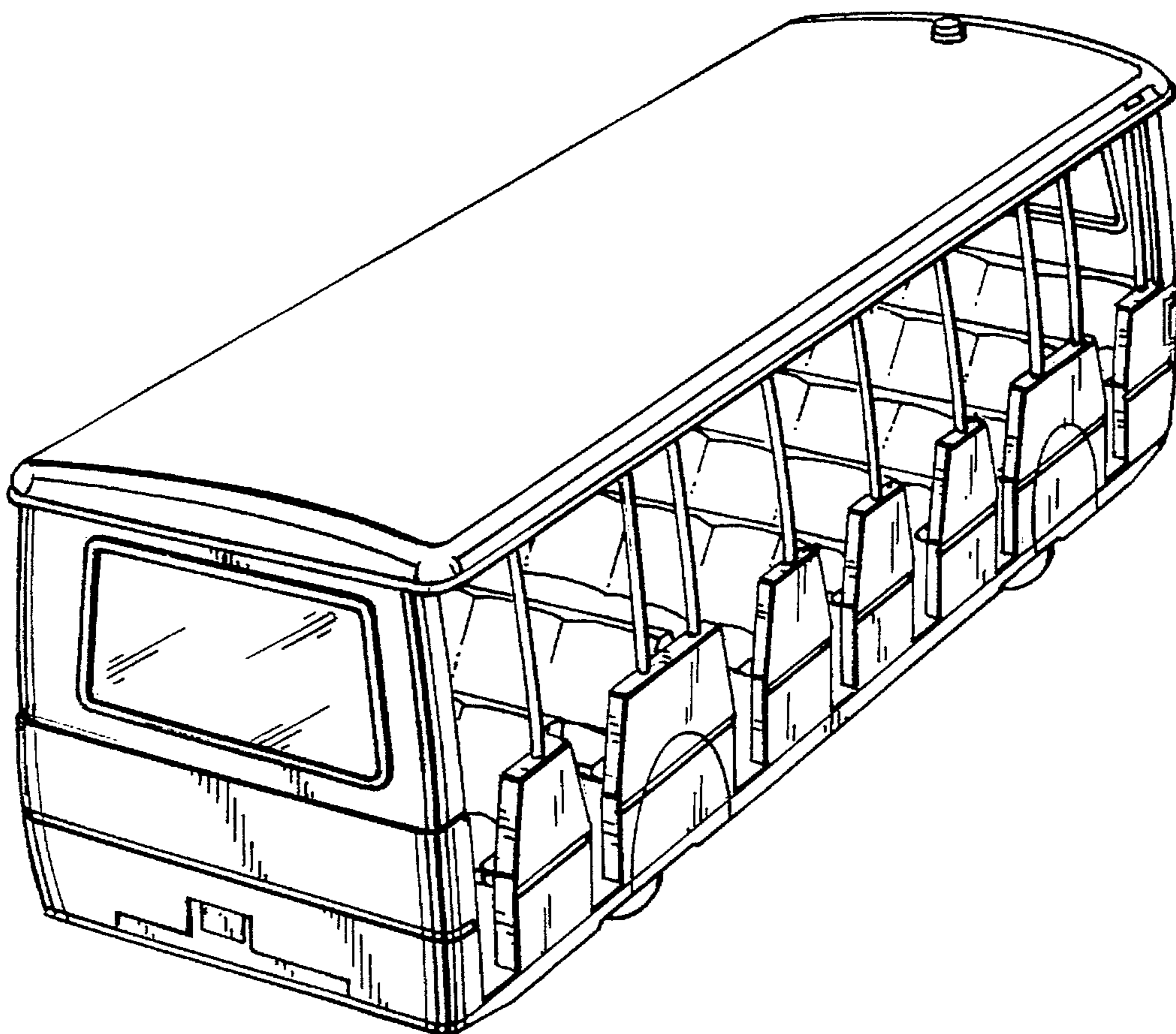

Fig. 3.

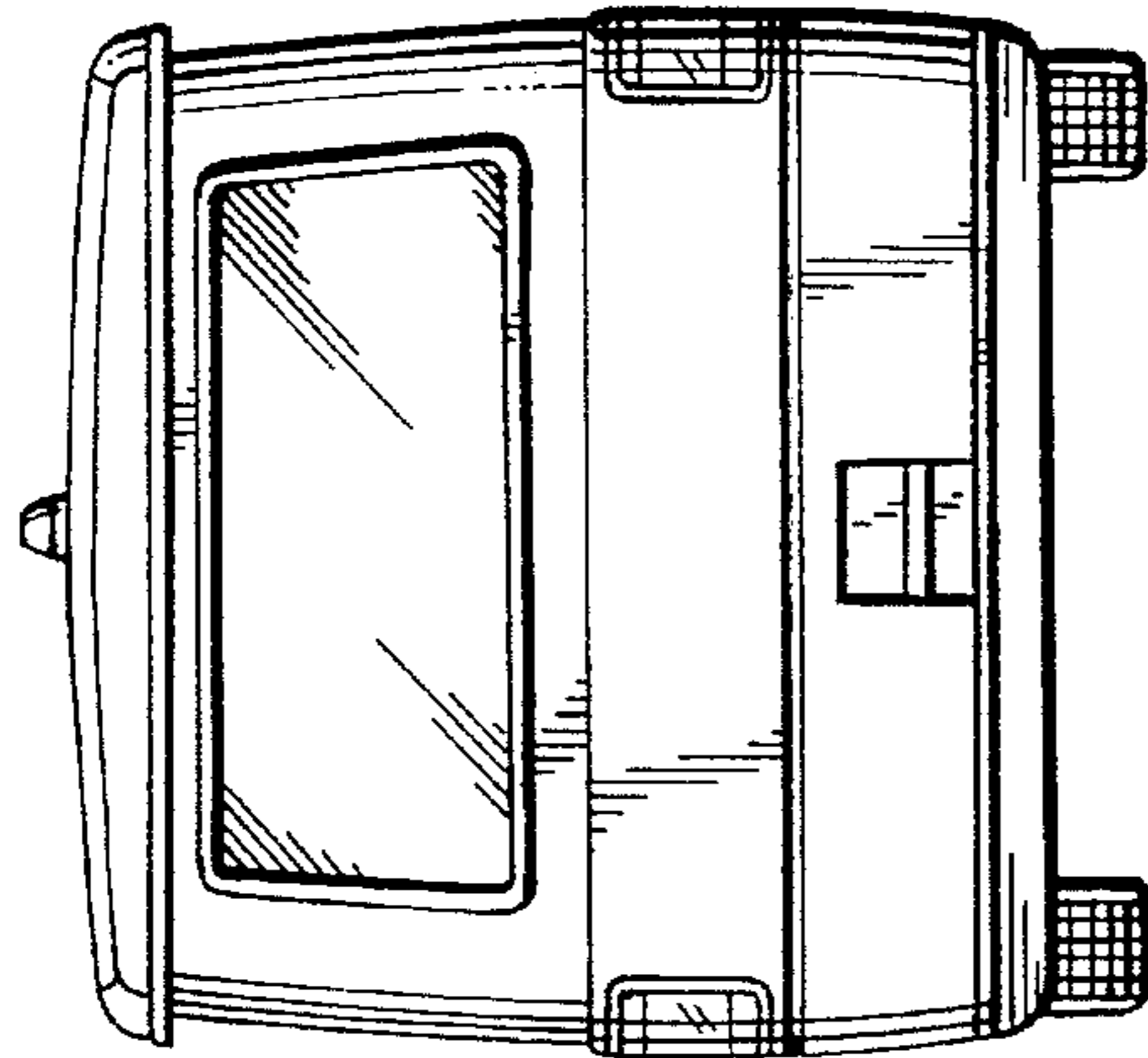

Fig. 2.

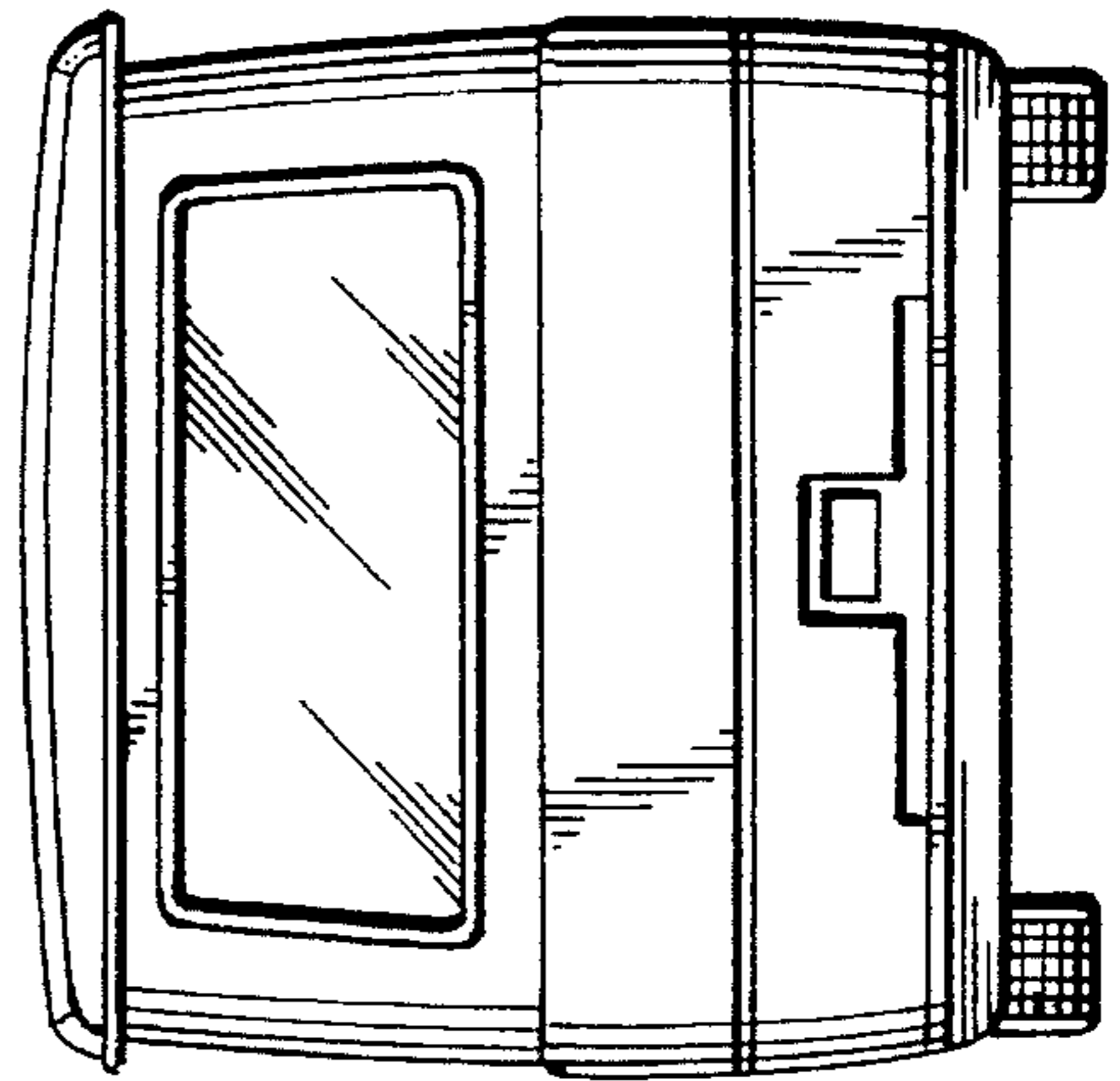

Fig. 1.

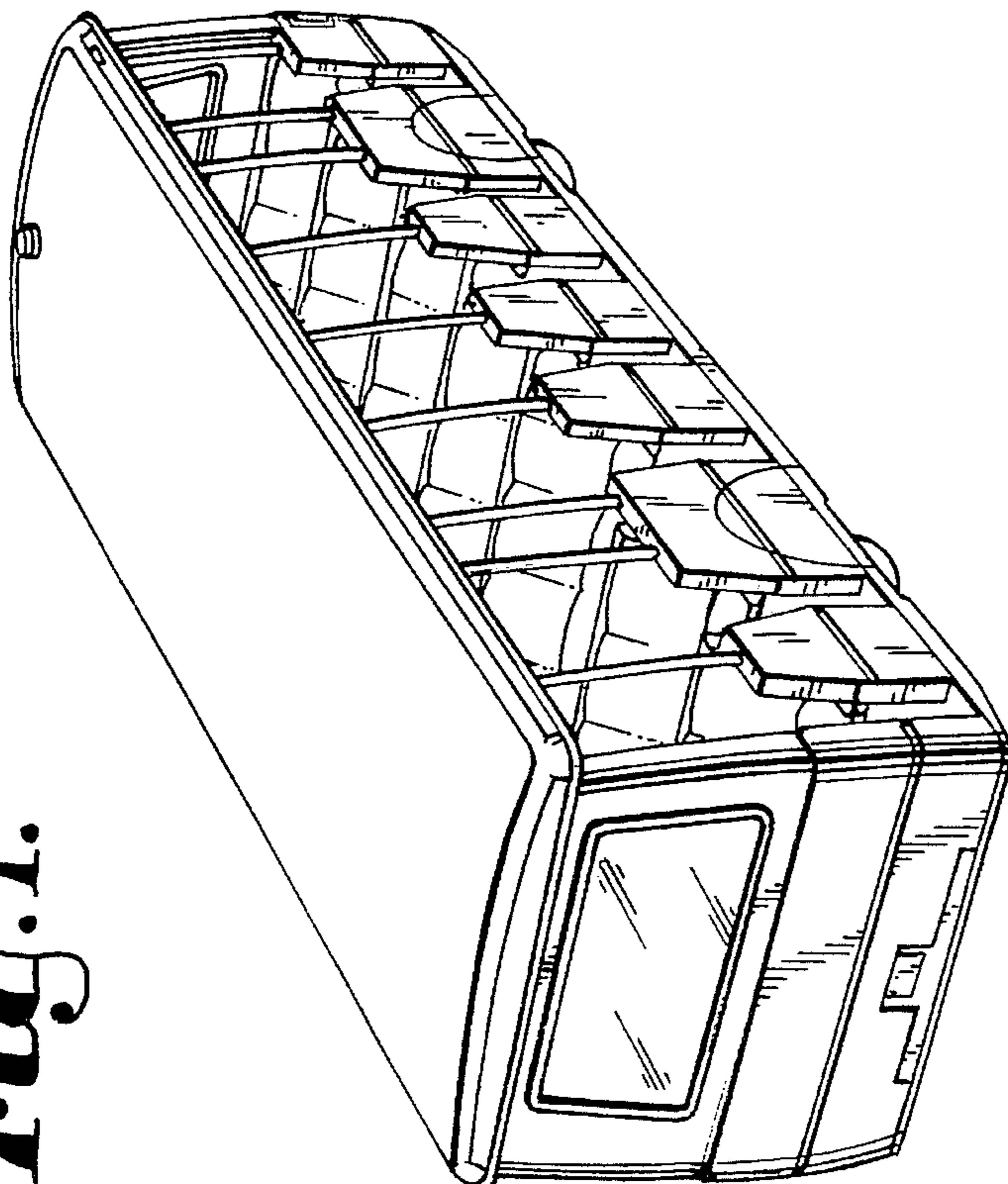

Fig. 4.

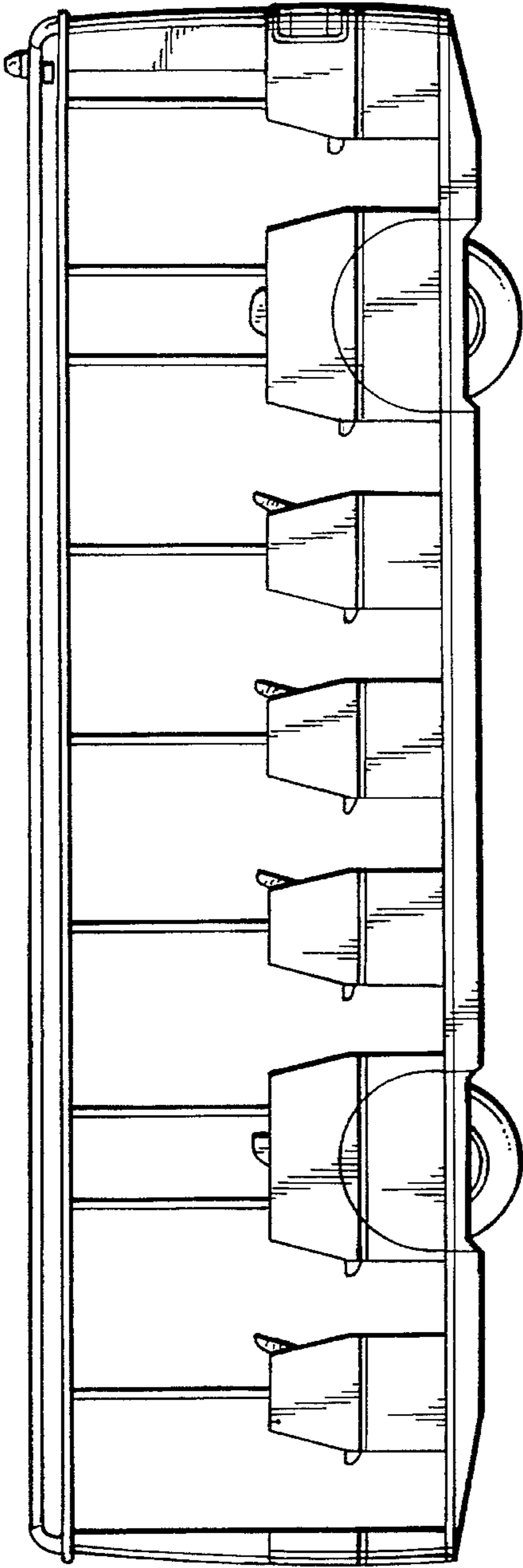

Fig. 5.

