



US00D378824S

United States Patent [19] Nestvall

[11] Patent Number: **Des. 378,824**

[45] Date of Patent: ****Apr. 15, 1997**

[54] **STEERING-GEAR**

4,962,717 10/1990 Tsumiyama 74/480 B

[75] Inventor: **Per Nestvall**, Mölndal, Sweden

Primary Examiner—Antoine Duval Davis
Attorney, Agent, or Firm—Lerner, David, Littenberg, Krumholz & Mentlik

[73] Assignee: **AB Volvo Penta**, Sweden

[**] Term: **14 Years**

[57] **CLAIM**

[21] Appl. No.: **49,615**

The ornamental design for a steering-gear, as shown.

[22] Filed: **Jan. 4, 1996**

DESCRIPTION

[30] **Foreign Application Priority Data**

Jul. 7, 1995 [SE] Sweden 95-1357

[52] **U.S. Cl.** **D15/148**

[58] **Field of Search** D12/317; D15/148,
D15/149; 74/99 R, 480 B, 552; 144/144 R;
440/1, 2, 42, 60, 61, 87

FIG. 1 is a perspective view of a steering-gear showing my new design seen from the front top end;

FIG. 2 is a perspective view of the steering-gear seen from the front bottom end;

FIG. 3 is a perspective view of the steering-gear seen from the back bottom end; and,

FIG. 4 is a bottom end view of the steering-gear.

[56] **References Cited**

U.S. PATENT DOCUMENTS

4,181,032 1/1980 Wagner et al. 74/99 R

1 Claim, 4 Drawing Sheets

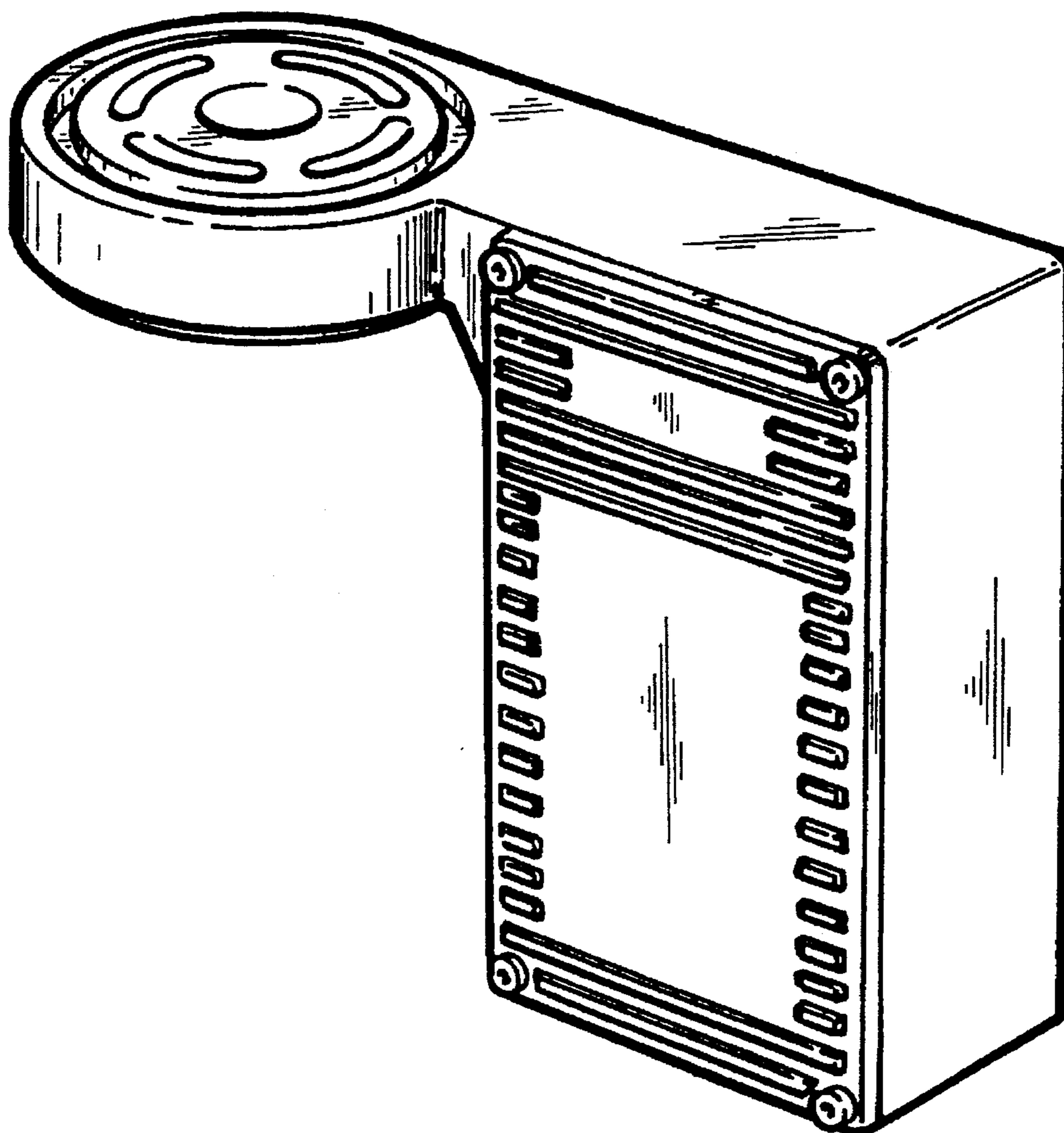

FIG. 1

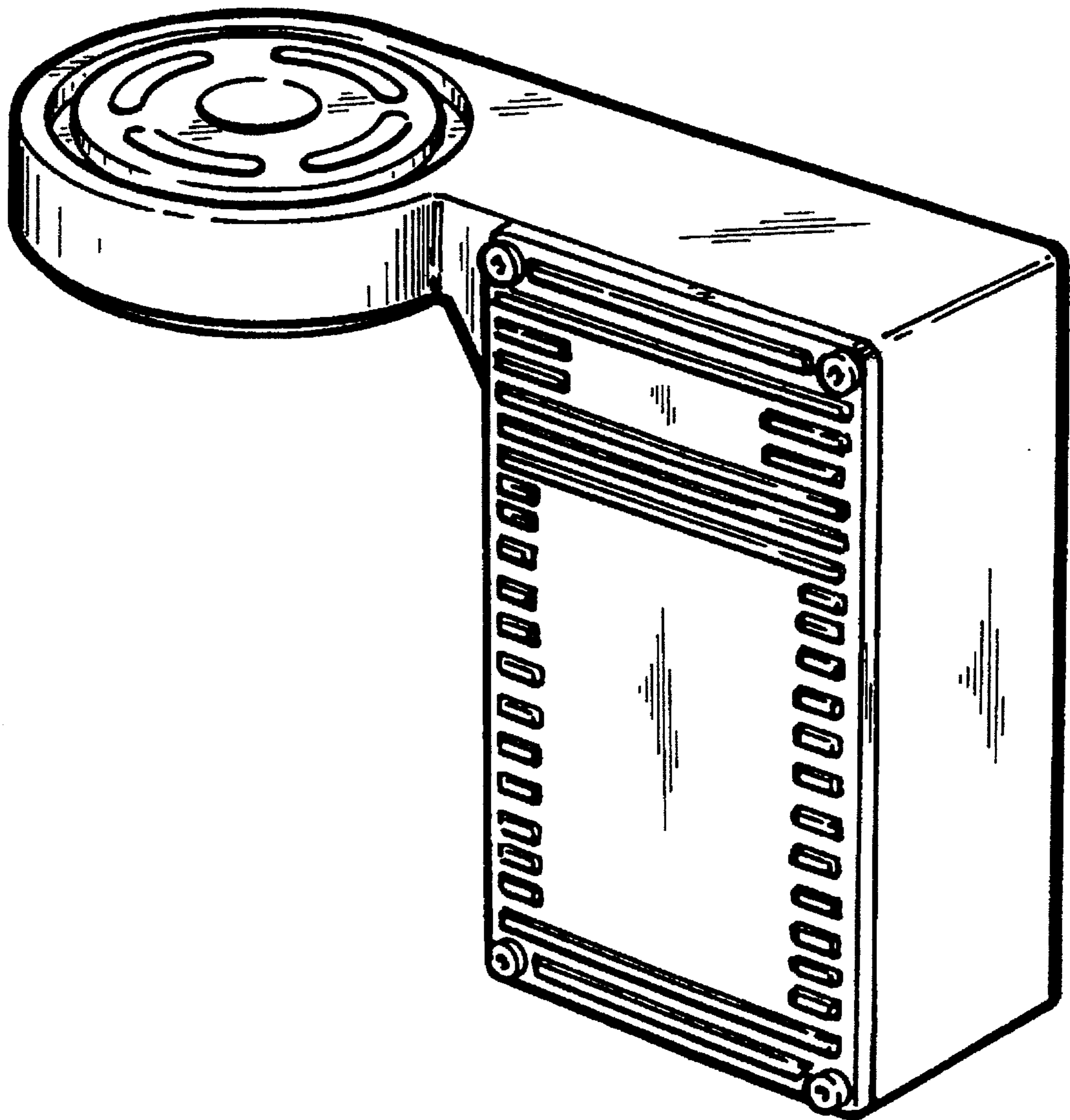

FIG. 2

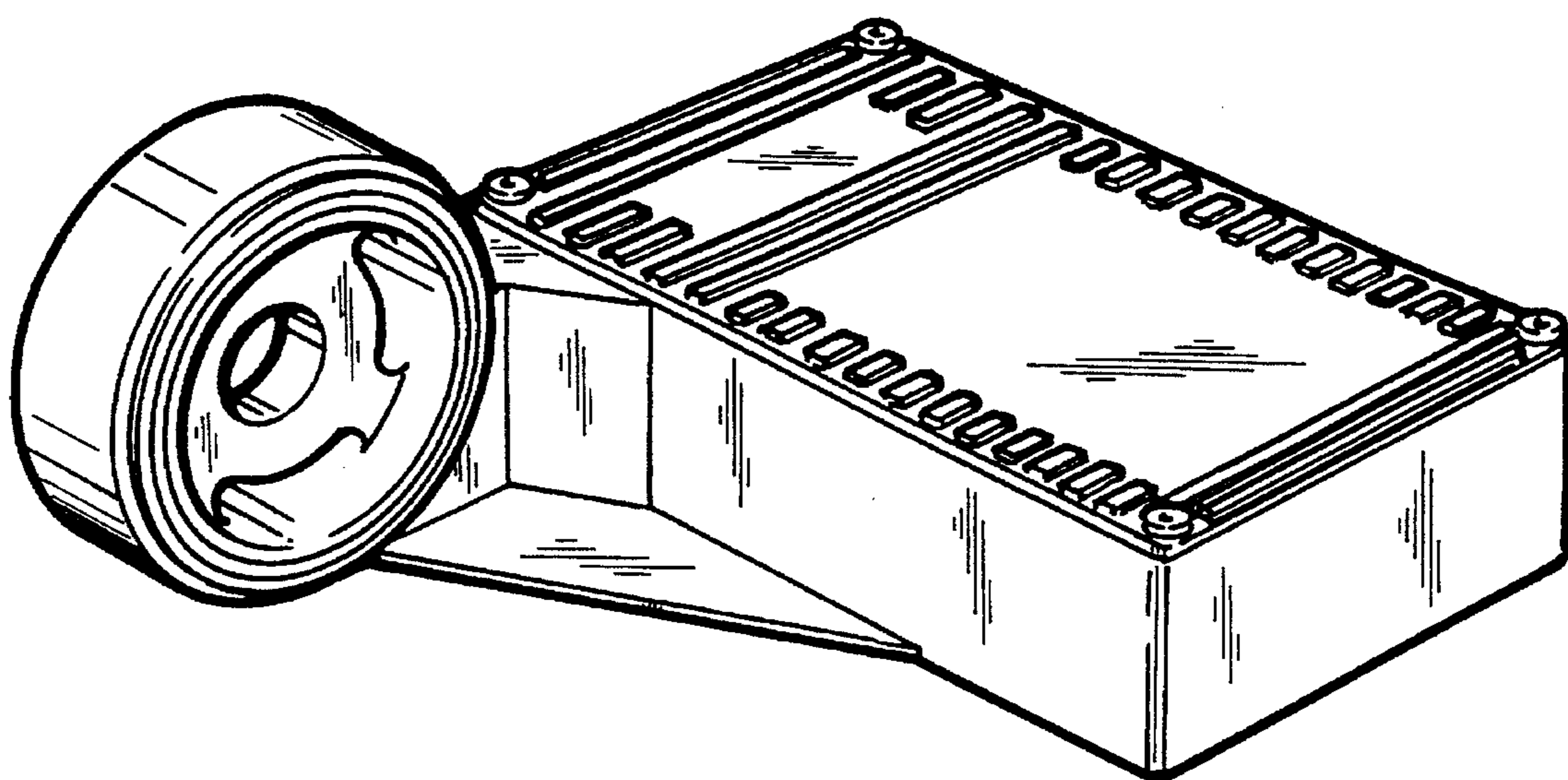

FIG. 3

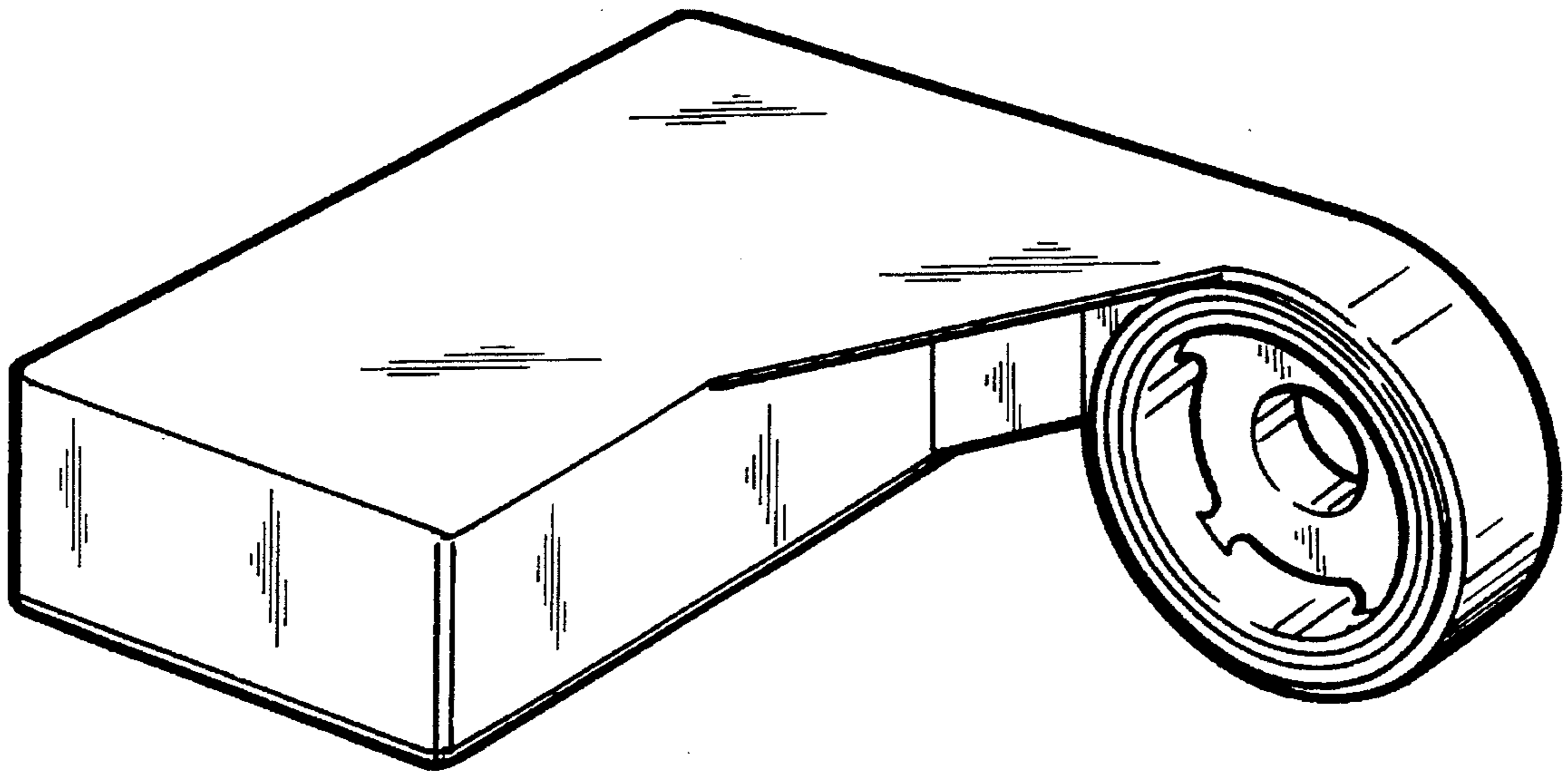

FIG. 4

