



US00D378716S

# United States Patent [19]

[11] Patent Number: **Des. 378,716**

Mann et al.

[45] Date of Patent: **\*\*Apr. 8, 1997**

[54] **CHEST**

[75] Inventors: **Phylliss Mann**, Los Angeles; **Lawrence Platt**, Beverly Hills, both of Calif.

[73] Assignee: **Cal-Marble Furniture Mfg. Corp.**, El Monte, Calif.

[\*\*] Term: **14 Years**

[21] Appl. No.: **34,154**

[22] Filed: **Jan. 27, 1995**

[52] U.S. Cl. .... **D6/434**; D6/446

[58] Field of Search ..... D6/432-448, 396, D6/397; 312/204, 257, 114

[56] **References Cited**

**U.S. PATENT DOCUMENTS**

D. 151,215	10/1948	Buckner .....	D6/446
D. 154,920	8/1949	Guild et al. ....	D6/446
D. 158,930	6/1950	Burgold .....	D6/446
D. 183,847	11/1958	Lubberts et al. ....	D6/446
D. 244,111	4/1977	Friedman .....	D6/446
D. 325,831	5/1992	Rosen .....	D6/446
D. 355,084	2/1995	Rosen .....	D6/446

**OTHER PUBLICATIONS**

- Architectural Digest*, Sep. 1987, (2 pages).
- Architectural Digest*, Nov. 1987, (2 pages).
- Architectural Digest*, Feb. 1988, (2 pages).
- Architectural Digest*, May 1988, (3 pages).
- Architectural Digest*, Apr. 1992, (2 pages).
- Art Deco*, V. Arwas, Harry N. Abrams, Inc., (9 pages, including pp. 26, 50, 53, 67, 69, 88, 91) (1980).
- Art Deco Furniture—The French Designers*, A. Duncan, Holt, Rinehart & Winston, (1984), (8 pages).
- The Art Nouveau Style*, R. Waddell (editor), Dover Publications, Inc., (4 pages, including pp. 338, 548) (1977).
- Butterfield & Butterfield*, Apr. 30 and May 1, 1990, Los Angeles (2 pages).
- Empire Style Designs and Ornaments*, J. Beunat (3 pages).
- House & Garden*, May 1987, (2 pages).

- House & Garden*, Jul. 1987, (2 pages).
- House & Garden*, Nov. 1987, (2 pages).
- House & Garden*, Dec. 1987, (2 pages).
- Interior Design*, Jul. 1987, 292, (2 pages).
- Interior Design*, Sep. 1987, (6 pages).
- Interior Design*, Dec. 1987, (2 pages, including p. 102).
- Interior Design*, Jan. 1988, (6 pages).
- Interior Design*, Mar. 1988, (3 pages).
- Interior Design*, May 1988, (6 pages).
- Interior Design*, Dec. 1988, (2 pages).
- Interior Design*, Jan. 1989, (2 pages).
- Interior Design*, Jun. 1990, (4 pages).
- Lewis Mittman Inc.*, vol. V, (2 pages, including p. 85 (showing headboard).
- Neoclassicism in the North*, Rizzoli International Publications, Inc. (1990), (7 pages).
- The Story of Furniture*, J. Raynsford, The Hamlyn Publishing Group Ltd., (4 pages, including p. 8, 37-38) (1975).
- Source Unknown—showing various moulding designs (1 page) Date Prior to Jan. 27, 1995.

*Primary Examiner*—Carmen H. Vales-Lado  
*Attorney, Agent, or Firm*—Poms, Smith, Lande & Rose

[57] **CLAIM**

The ornamental design for a chest, as shown and described.

**DESCRIPTION**

FIG. 1 is a perspective view of a chest showing our new design;  
 FIG. 2 is a front elevational view thereof;  
 FIG. 3 is a right side elevational view, the left side being identical thereto;  
 FIG. 4 is a perspective view of a second embodiment of the chest shown in FIG. 1;  
 FIG. 5 is a front elevational view thereof; the sides being identical that shown in FIG. 3;  
 FIG. 6 is a front elevational view of a third embodiment of the chest shown in FIG. 1; and,  
 FIG. 7 is a right side elevational view, the left side being identical thereto.

**1 Claim, 4 Drawing Sheets**

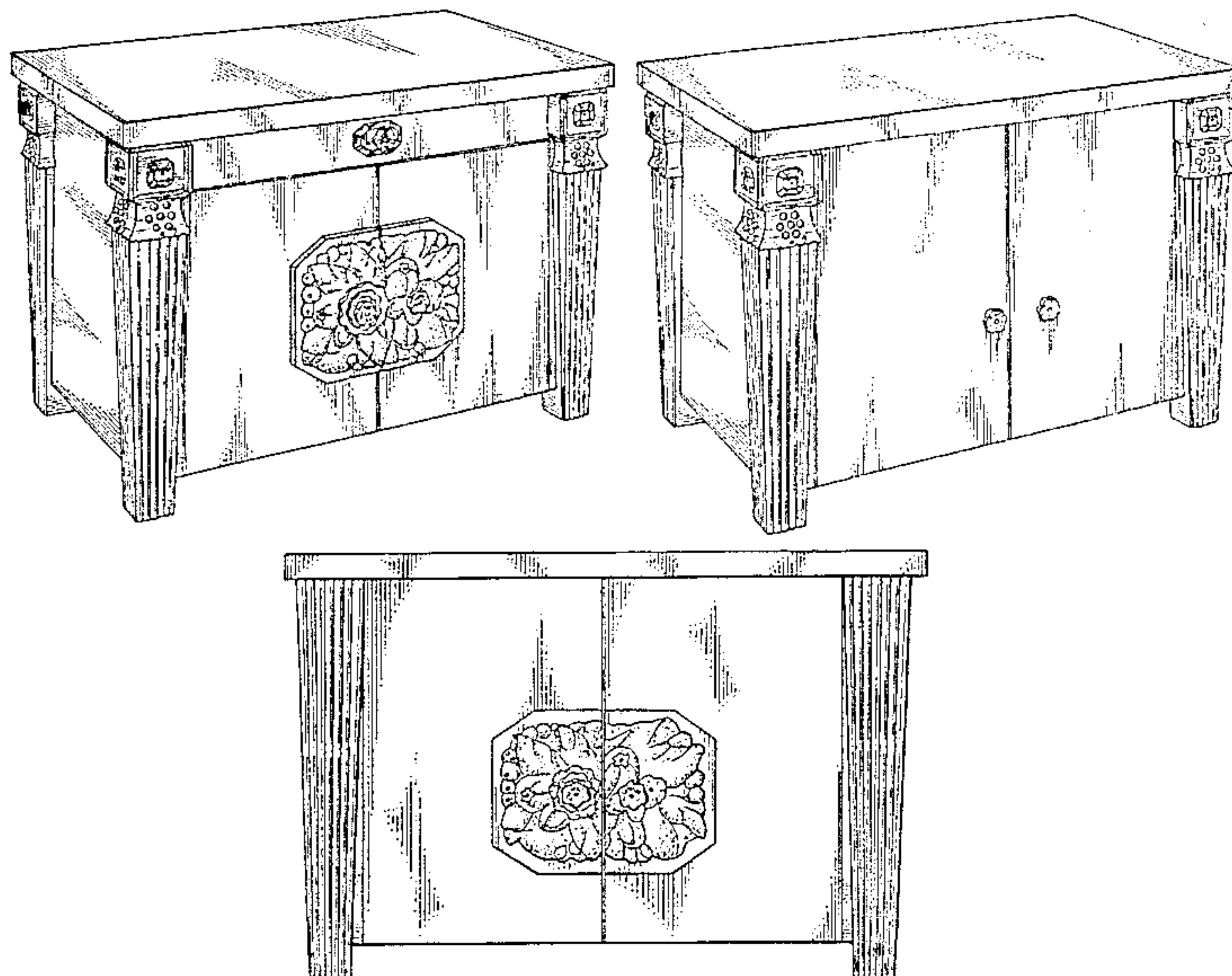



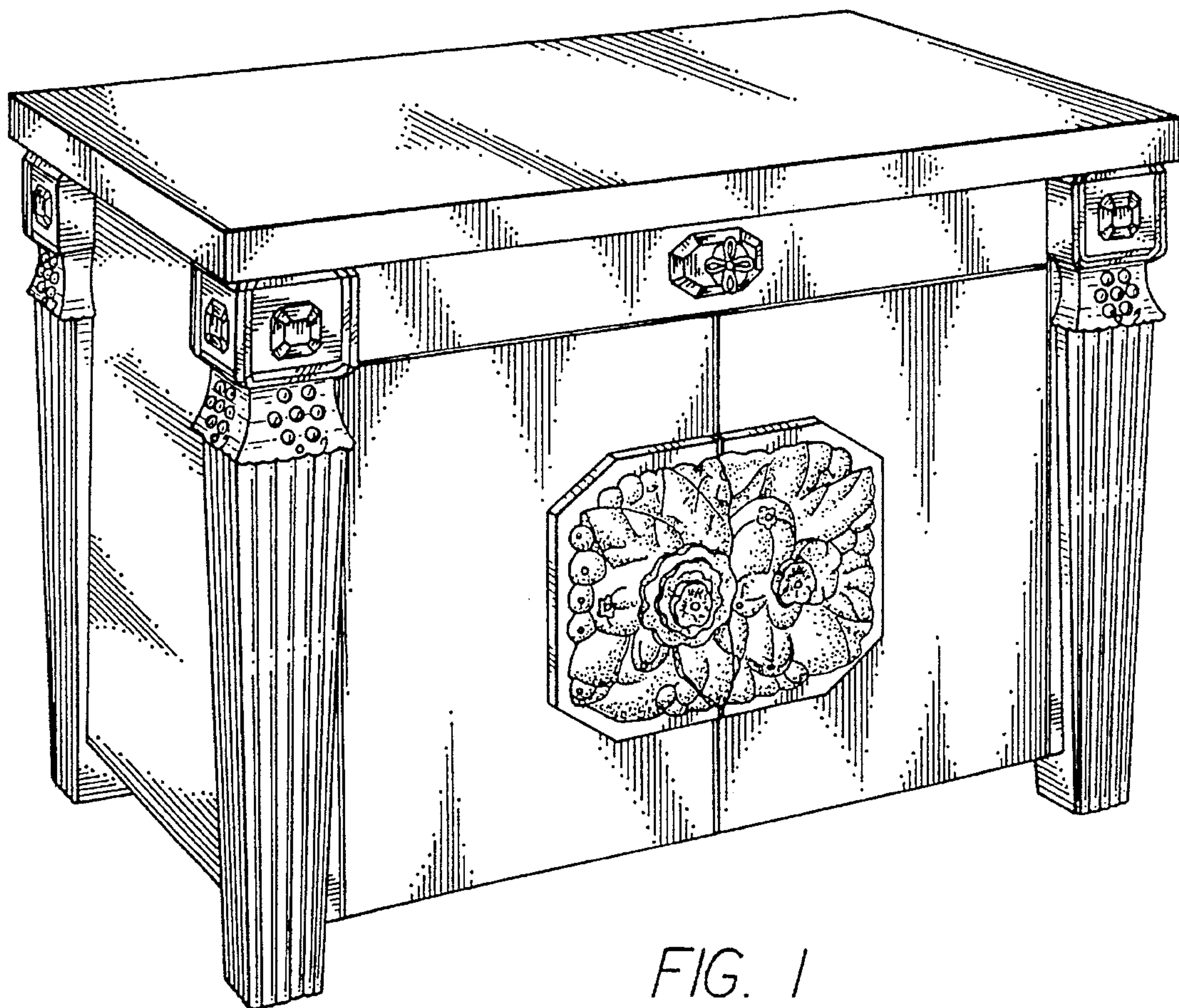

FIG. 1

FIG. 2

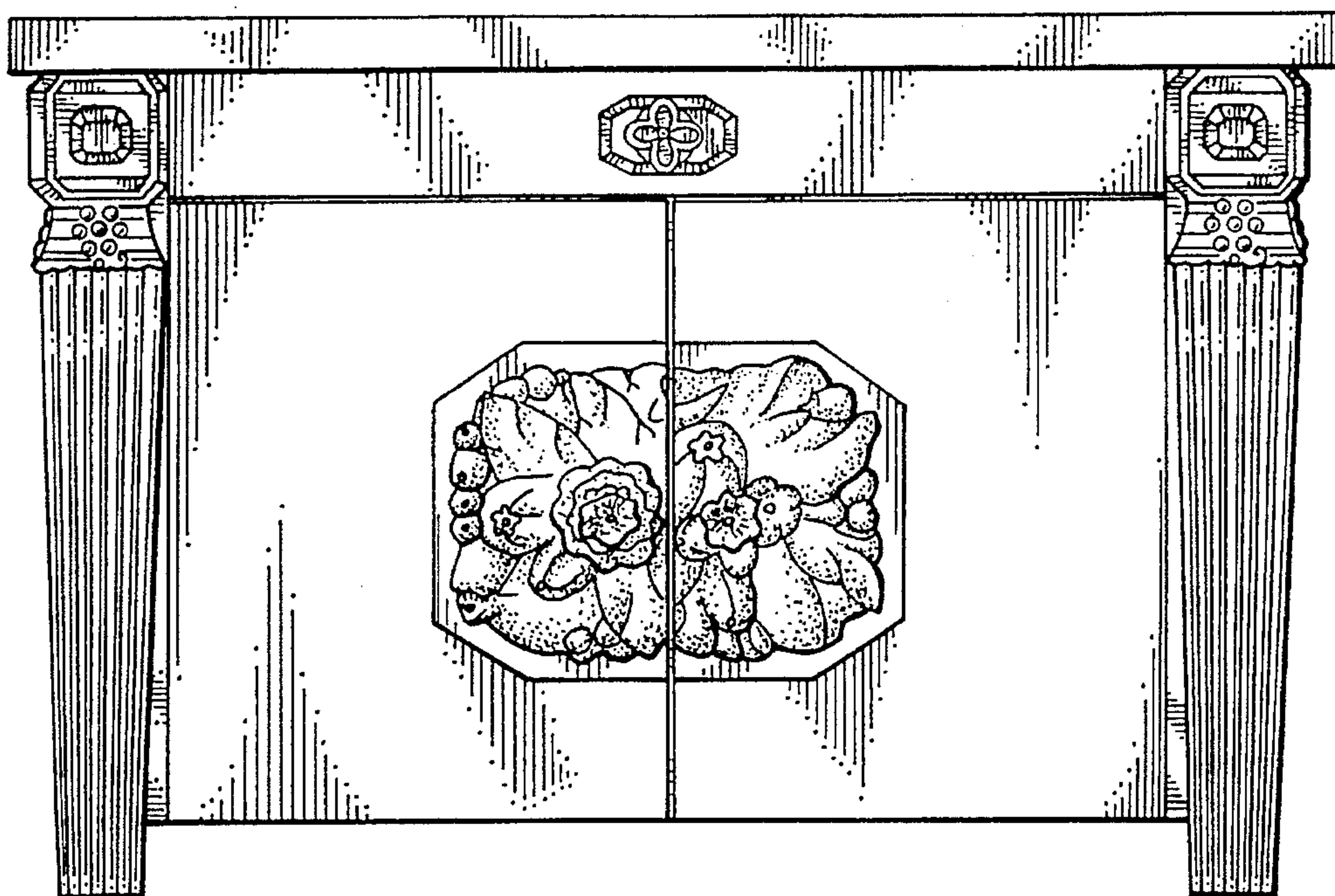

FIG. 3

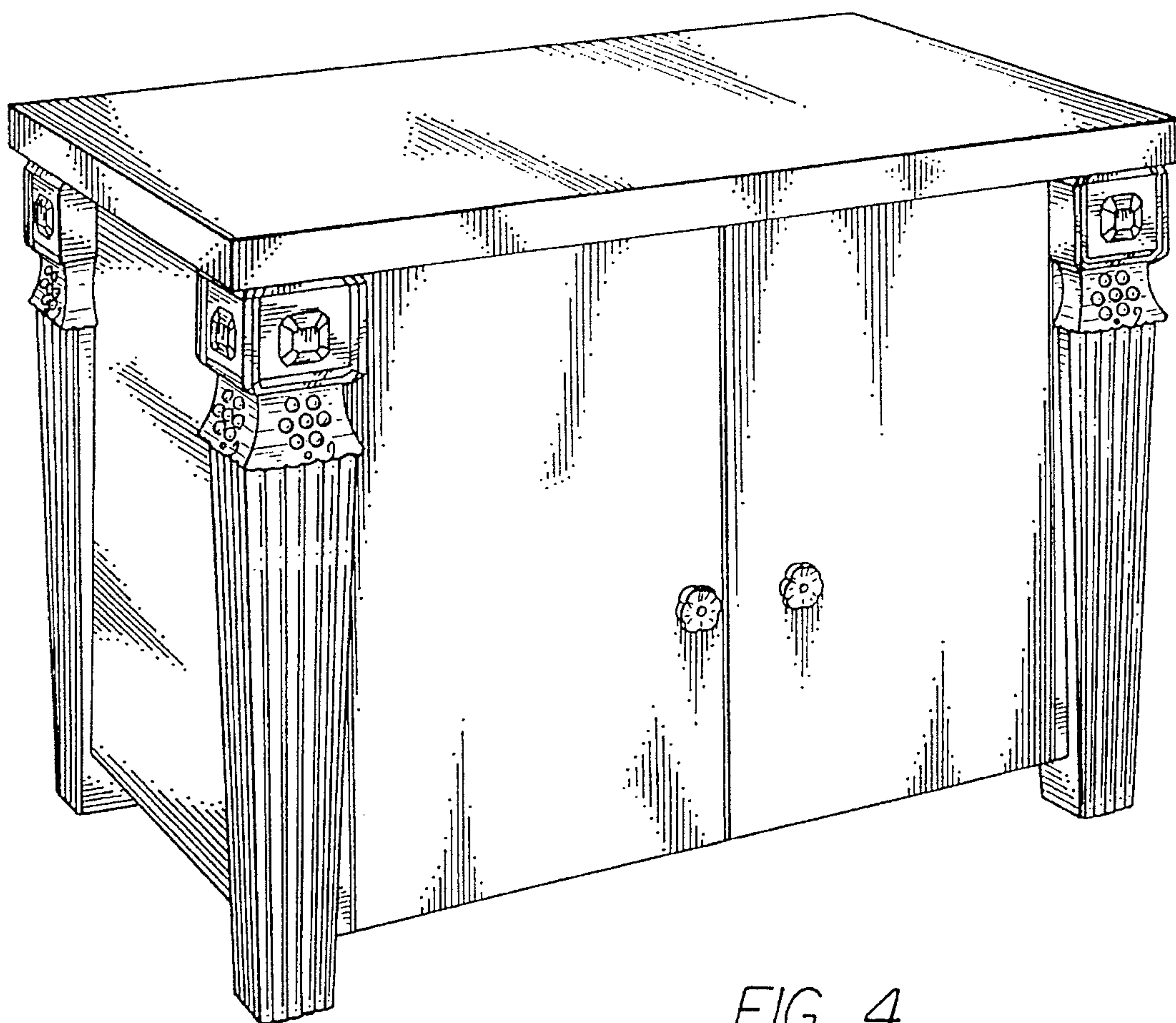
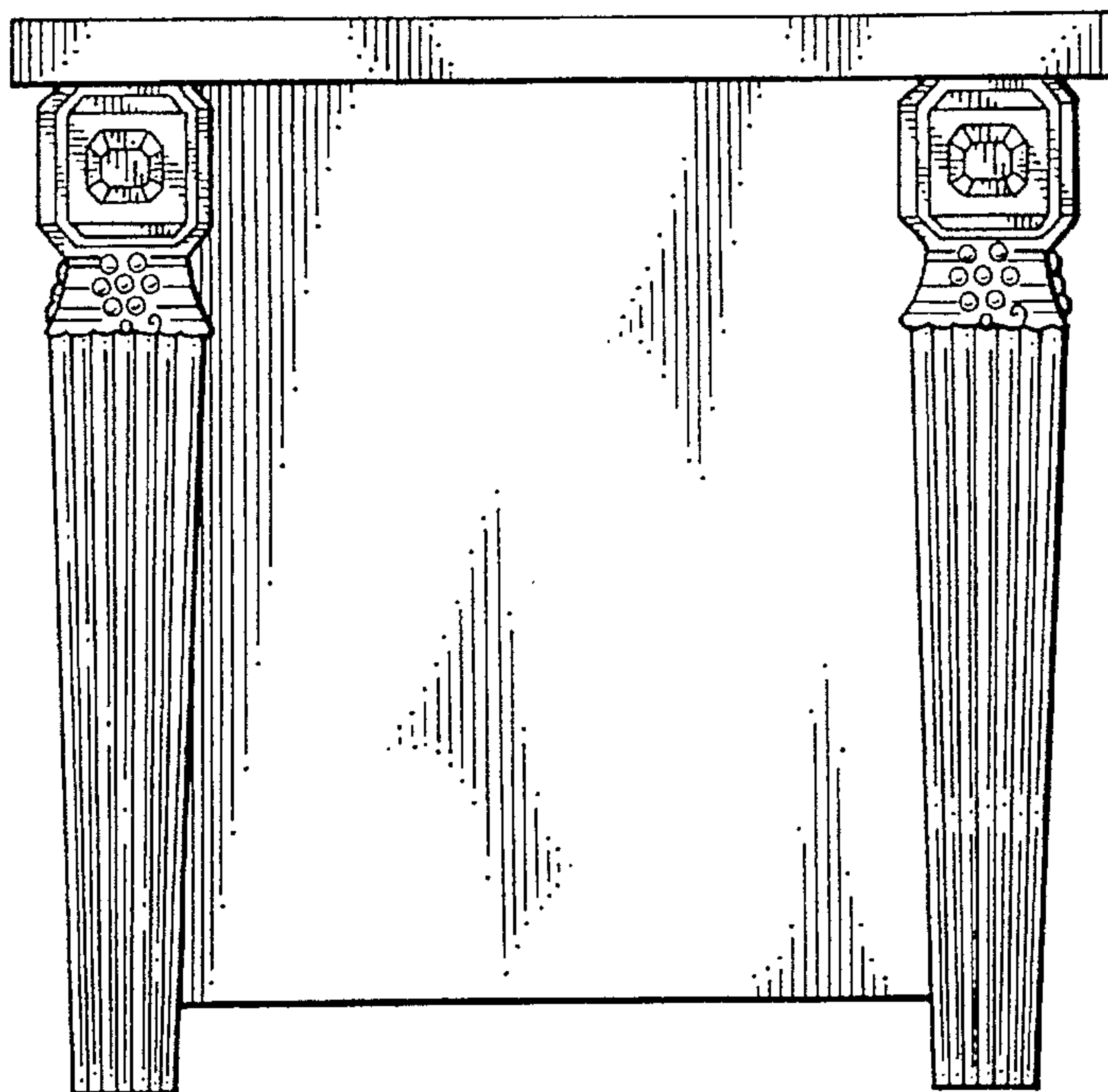

FIG. 4



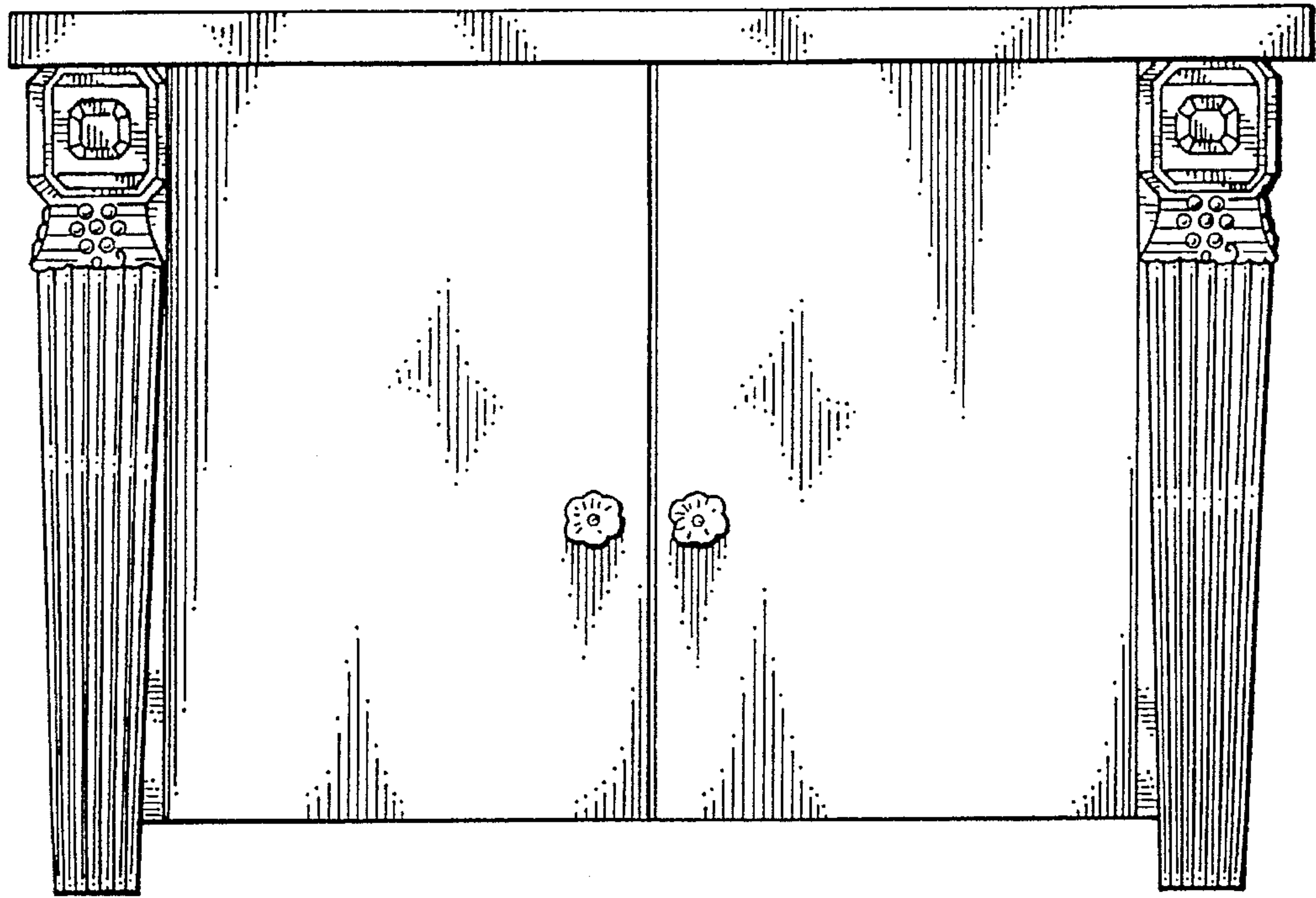
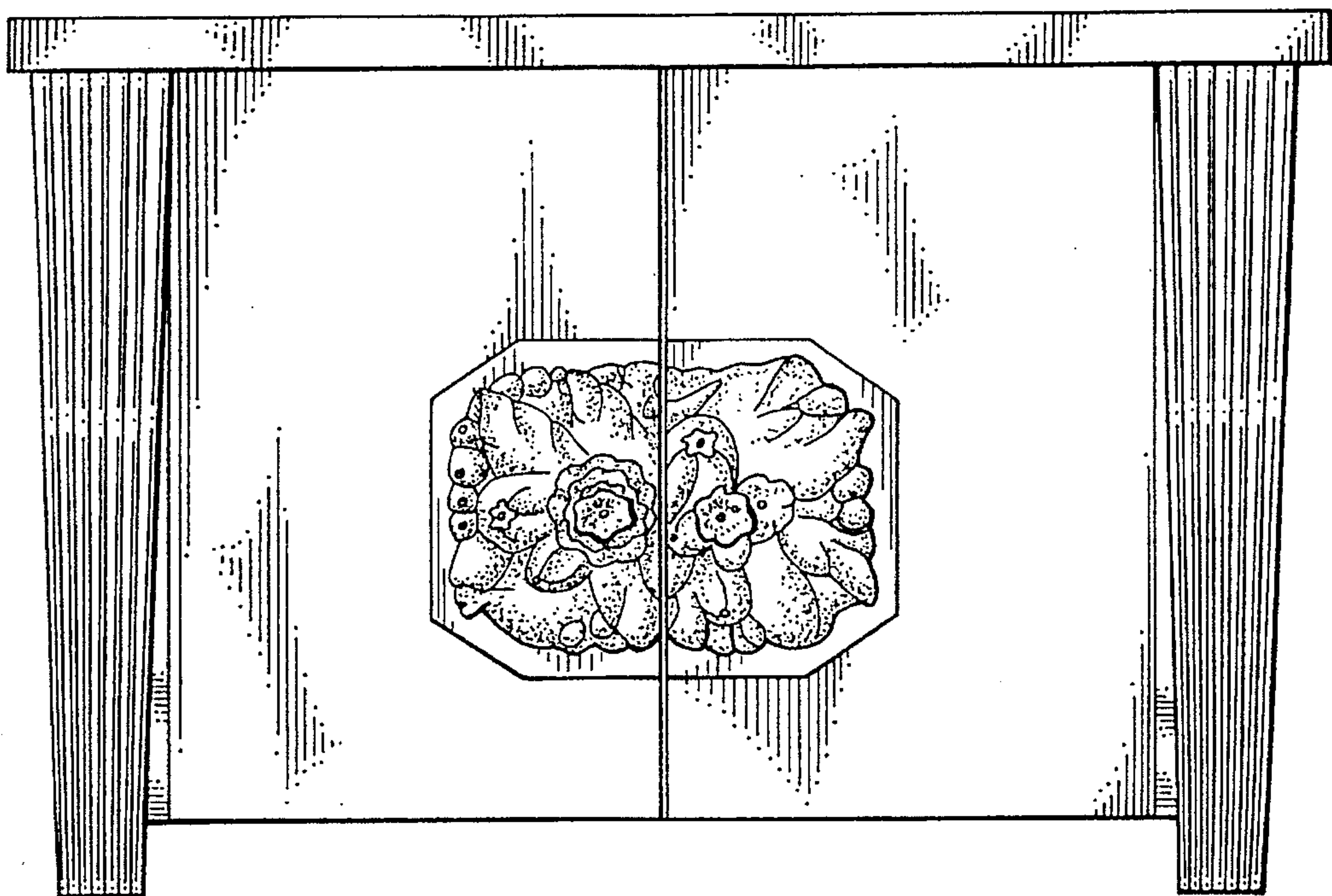

FIG. 5

FIG. 6



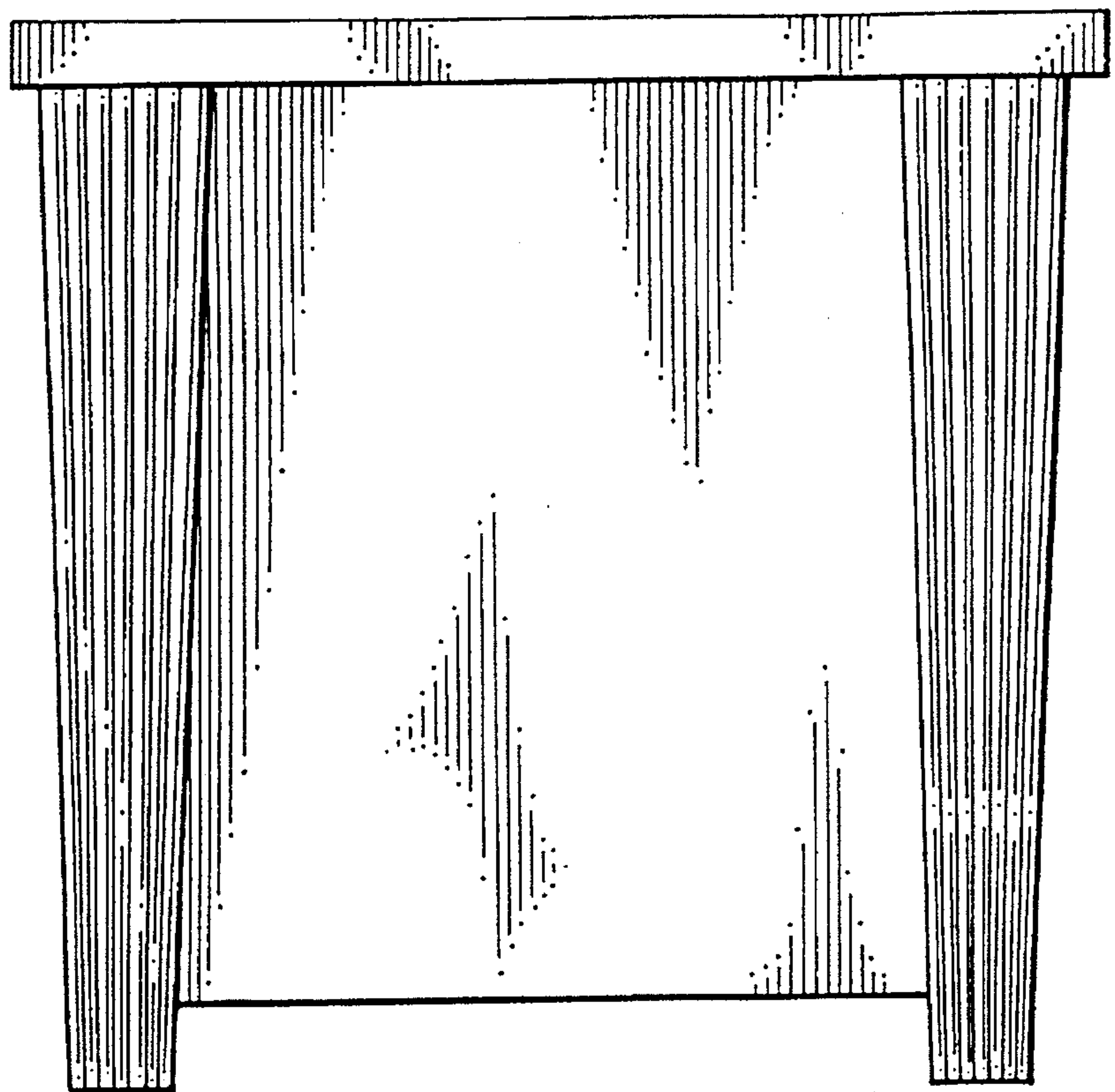

FIG. 7