



US00D378670S

# United States Patent [19]

[11] **Patent Number: Des. 378,670**

**Echazabal et al.**

[45] **Date of Patent: \*\*\*Apr. 1, 1997**

[54] **FRONT FACE OF A VEHICLE WHEEL**

[75] Inventors: **Alberto Echazabal**, Hialeah Gardens, Fla.; **Claudio Bernoni**, Albano Terma, Italy

[73] Assignee: **Motoring Accessories**, Miami, Fla.

[\*] Notice: The portion of the term of this patent subsequent to Aug. 1, 2009, has been disclaimed.

[\*\*] Term: **14 Years**

[21] Appl. No.: **38,113**

[22] Filed: **Apr. 28, 1995**

[52] U.S. Cl. .... **D12/209**

[58] Field of Search ..... D12/209, 211; 301/64.1, 65

[56] **References Cited**

**U.S. PATENT DOCUMENTS**

- D. 351,581 10/1994 Chung ..... D12/209
- D. 360,866 8/1995 Echazabal et al. .... D12/209

**OTHER PUBLICATIONS**

Custom Wheel & Tire Style Guide Supplement to Tire Review, May 1993, p. 51, Centra Type 30 Wheel, third box up from bottom right side of page.

Custom Wheel & Tire Style Guide Supplement to Tire Review, May 1993, p. 55, Superior G-5 Wheel, second box in from bottom left side of page.

Motor Trend, Apr. 1994, p. 110, Koni Antares II Five-Spoke Wheel, top right side of page.

*Primary Examiner*—Freda Nunn  
*Attorney, Agent, or Firm*—Longacre & White

[57] **CLAIM**

The ornamental design for the front face of a vehicle wheel, as shown and described.

**DESCRIPTION**

FIG. 1 is a perspective view of the front face of a vehicle wheel according to the present invention; and,

FIG. 2 is a front elevational view of the front face of a vehicle wheel, as shown in FIG. 1.

The broken line showing of environmental structure in the drawing is for illustrative purposes only and forms no part of the claimed design.

**1 Claim, 1 Drawing Sheet**

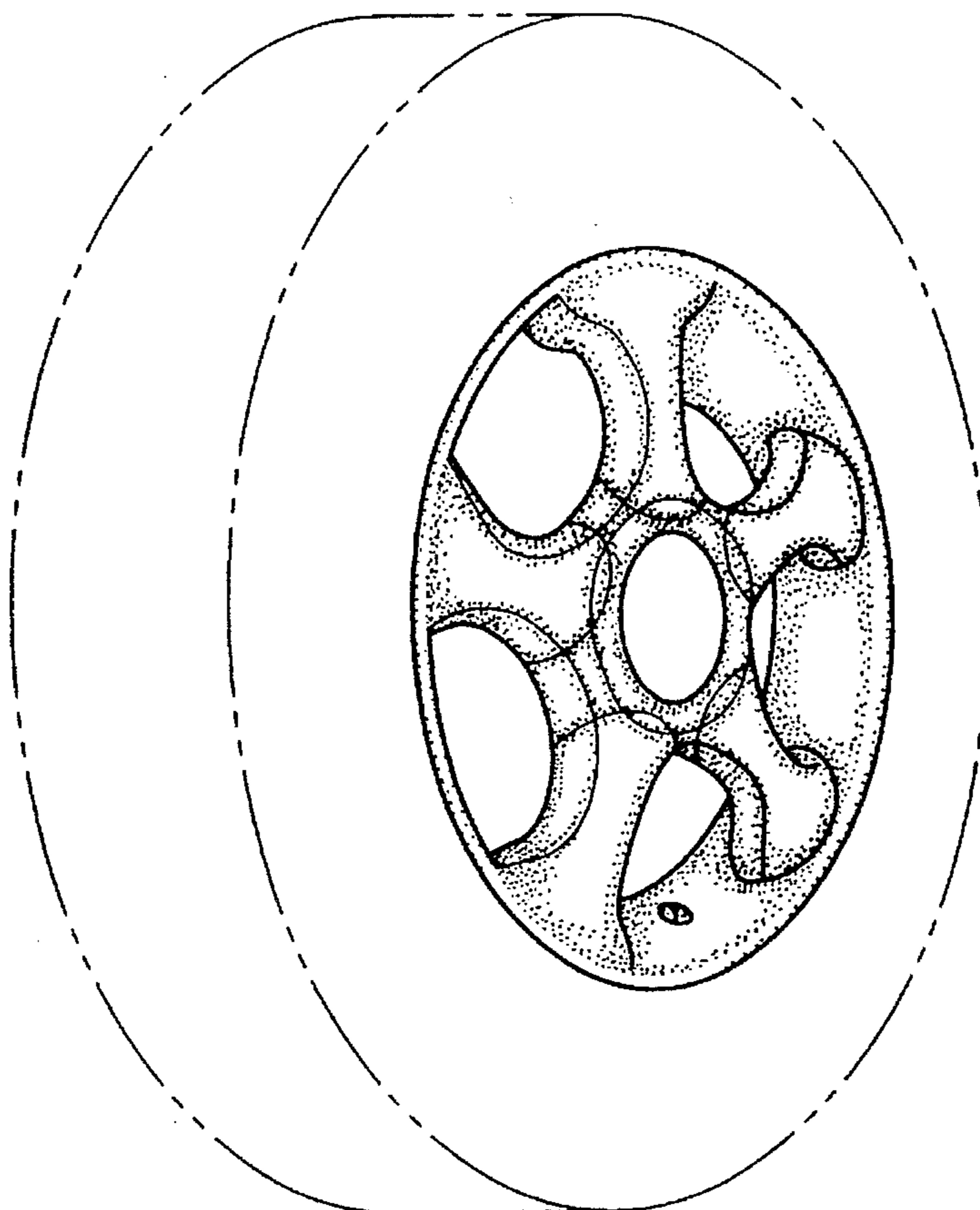

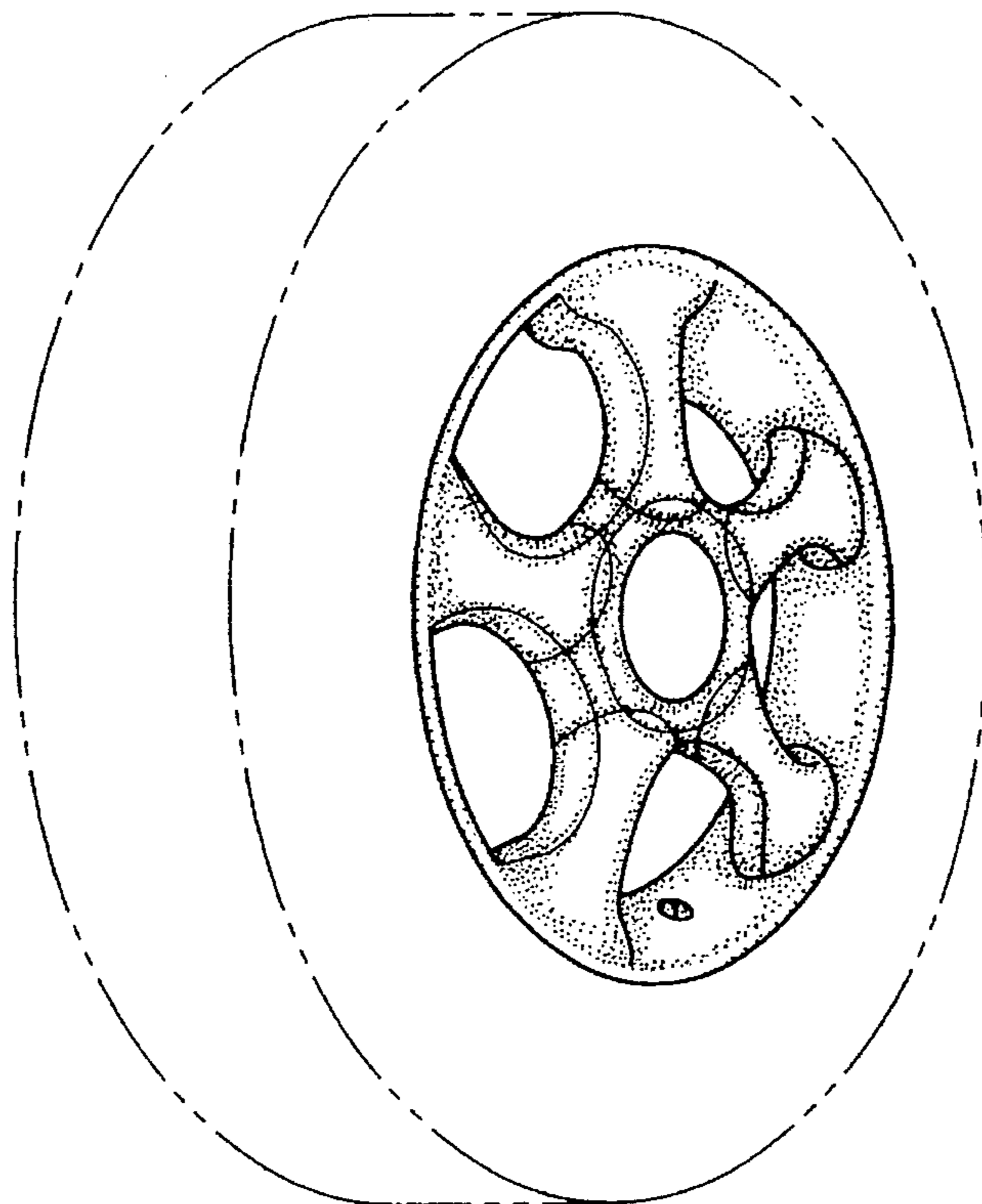

FIG. 1

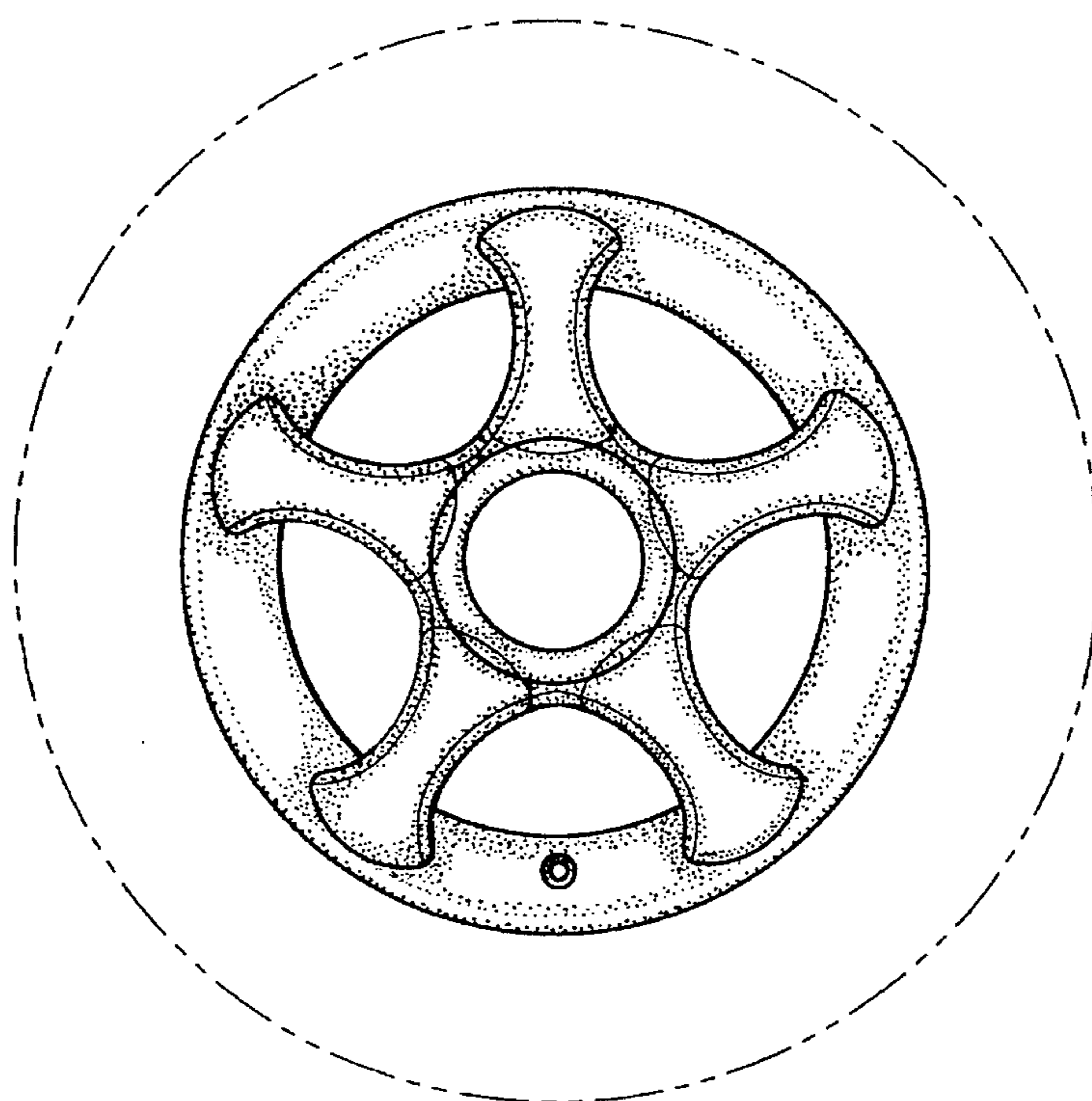

FIG. 2