



US00D378659S

# United States Patent [19]

[11] Patent Number: **Des. 378,659**

**Blennov**

[45] Date of Patent: **\*\*Apr. 1, 1997**

[54] **CONTROL CABLE CLAMP FOR MOTORCYCLES**

[76] Inventor: **Ole Blennov**, 229 S. Glasglow Ave., Inglewood, Calif. 90301

[\*\*] Term: **14 Years**

[21] Appl. No.: **39,742**

[22] Filed: **Jun. 5, 1995**

[52] U.S. Cl. .... **D8/396**

[58] Field of Search ..... D8/396; D23/265; 24/20 R, 21, 22, 20 LS; 16/114; 285/420; 248/74.4

|           |         |                    |            |
|-----------|---------|--------------------|------------|
| 4,439,902 | 4/1984  | Huxtable .....     | 248/74.4 X |
| 4,629,226 | 12/1986 | Cassel et al ..... | 285/420 X  |
| 5,048,776 | 9/1991  | Weiss .....        | 285/420 X  |
| 5,202,094 | 4/1993  | Jones et al. ....  | 16/114 R X |
| 5,462,212 | 10/1995 | Hertel, Jr. ....   | D8/396 X   |

*Primary Examiner*—Paula A. Mortimer  
*Attorney, Agent, or Firm*—Roger A. Marrs

[57] **CLAIM**

The ornamental design for control cable clamp for motorcycles, as shown and described.

**DESCRIPTION**

FIG. 1 is a rear perspective view of a control cable clamp for motorcycles showing my new design;  
FIG. 2 is a front perspective view thereof;  
FIG. 3 is a top plan view thereof;  
FIG. 4 is a rear elevational view thereof;  
FIG. 5 is a side elevational view thereof, the opposite side is a mirror image; and,  
FIG. 6 is a front elevational view thereof.

**1 Claim, 1 Drawing Sheet**

[56] **References Cited**

**U.S. PATENT DOCUMENTS**

|            |         |                   |            |
|------------|---------|-------------------|------------|
| D. 216,671 | 3/1970  | Turner .....      | D8/396     |
| D. 216,948 | 3/1970  | Turner .....      | D8/396     |
| D. 317,352 | 6/1991  | Takeuchi .....    | D23/265    |
| 3,182,940  | 5/1965  | Emery et al. .... | 248/74.4   |
| 3,330,517  | 7/1967  | Zimmermann .....  | 248/74.4 X |
| 4,059,872  | 11/1977 | Delesandri .....  | D8/396 X   |

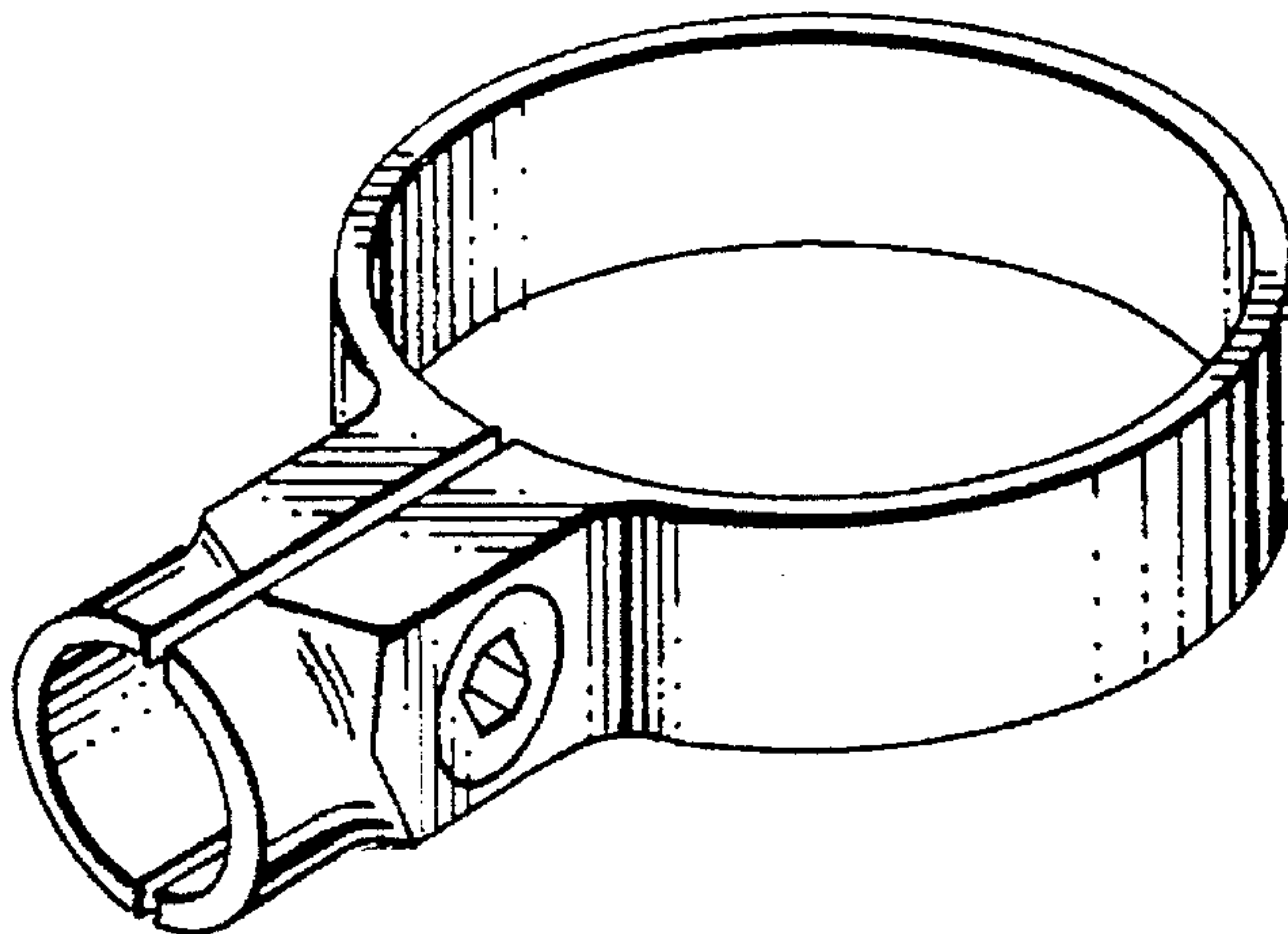

FIG. 1

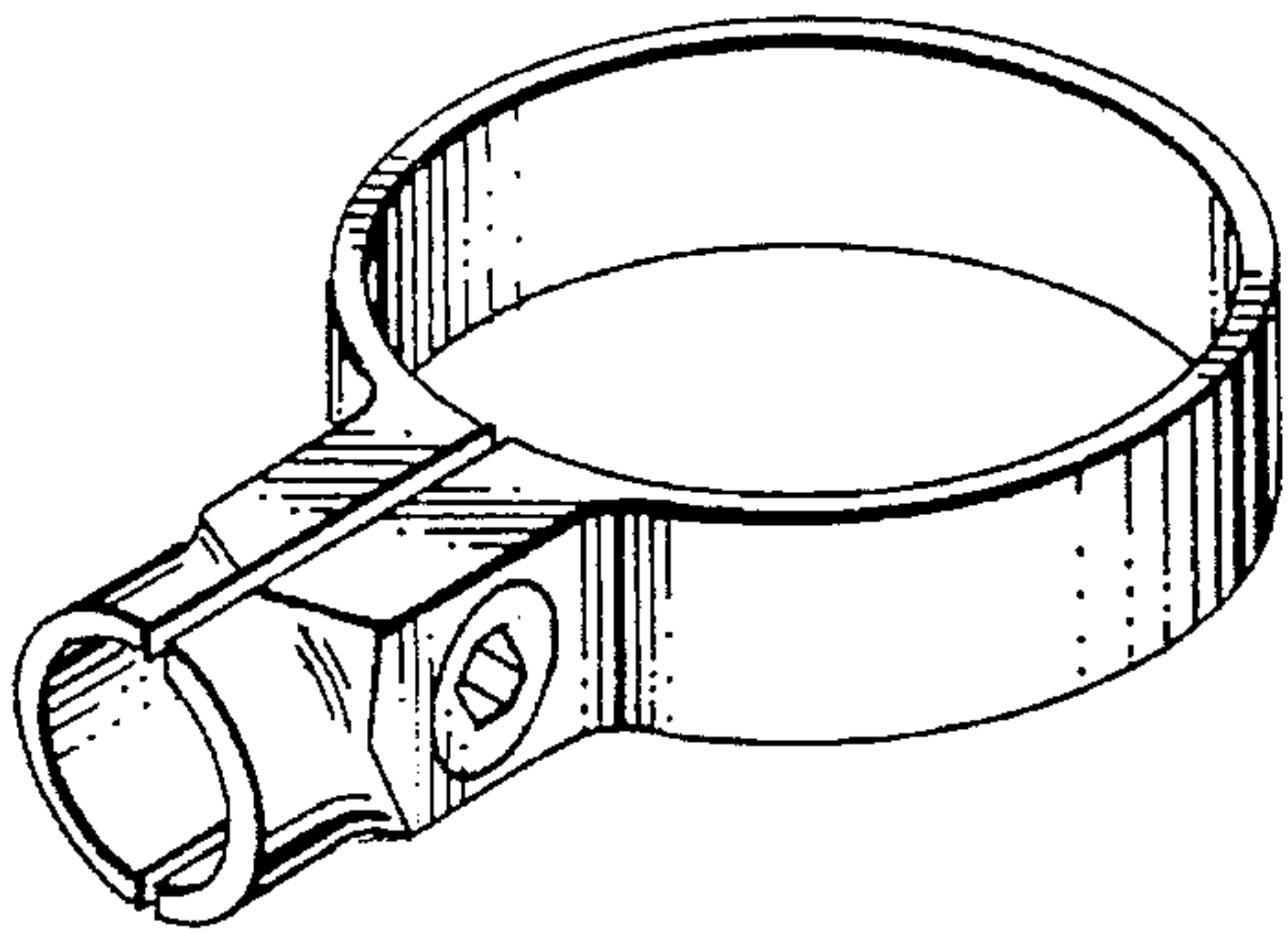

FIG. 2

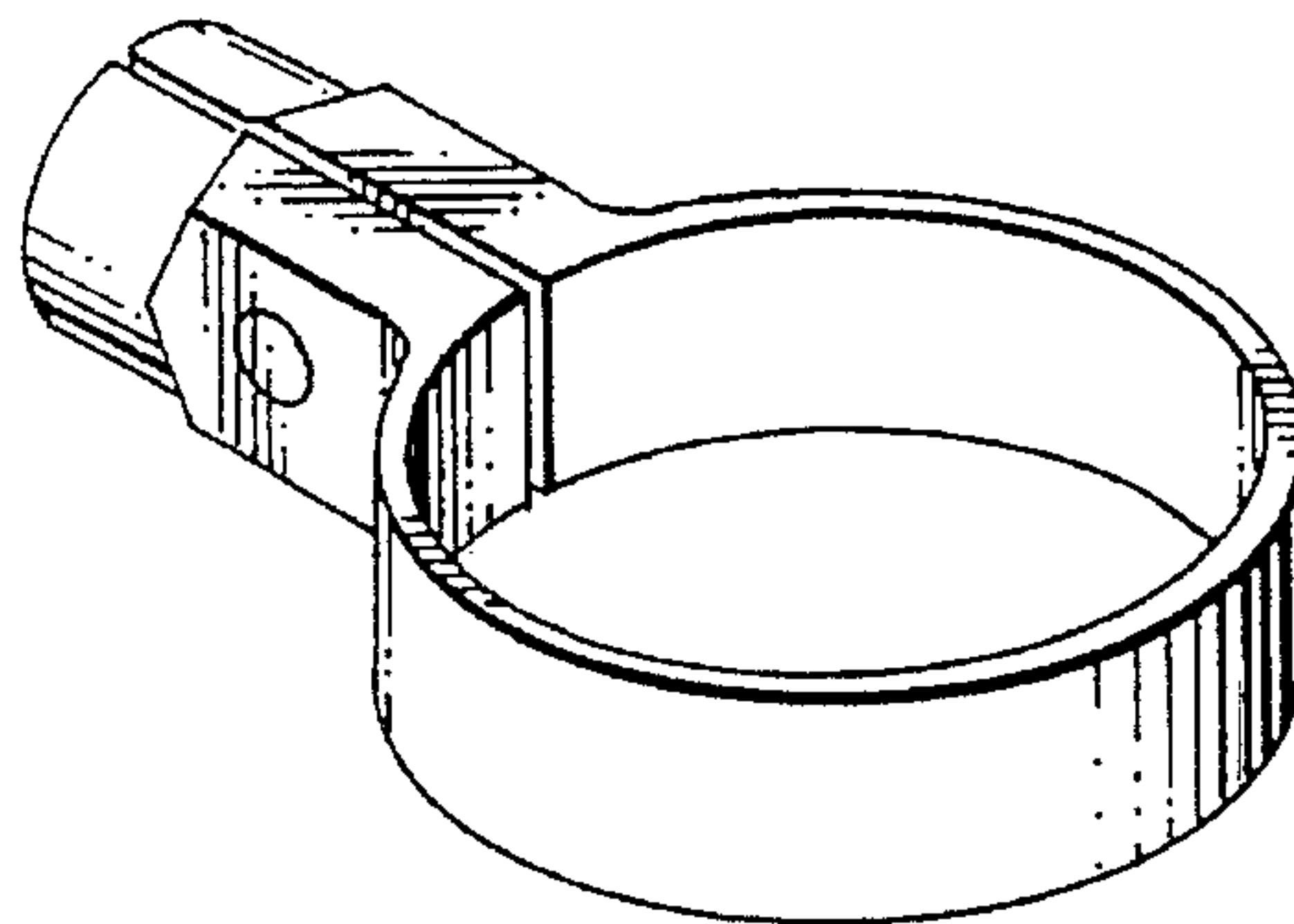

FIG. 3

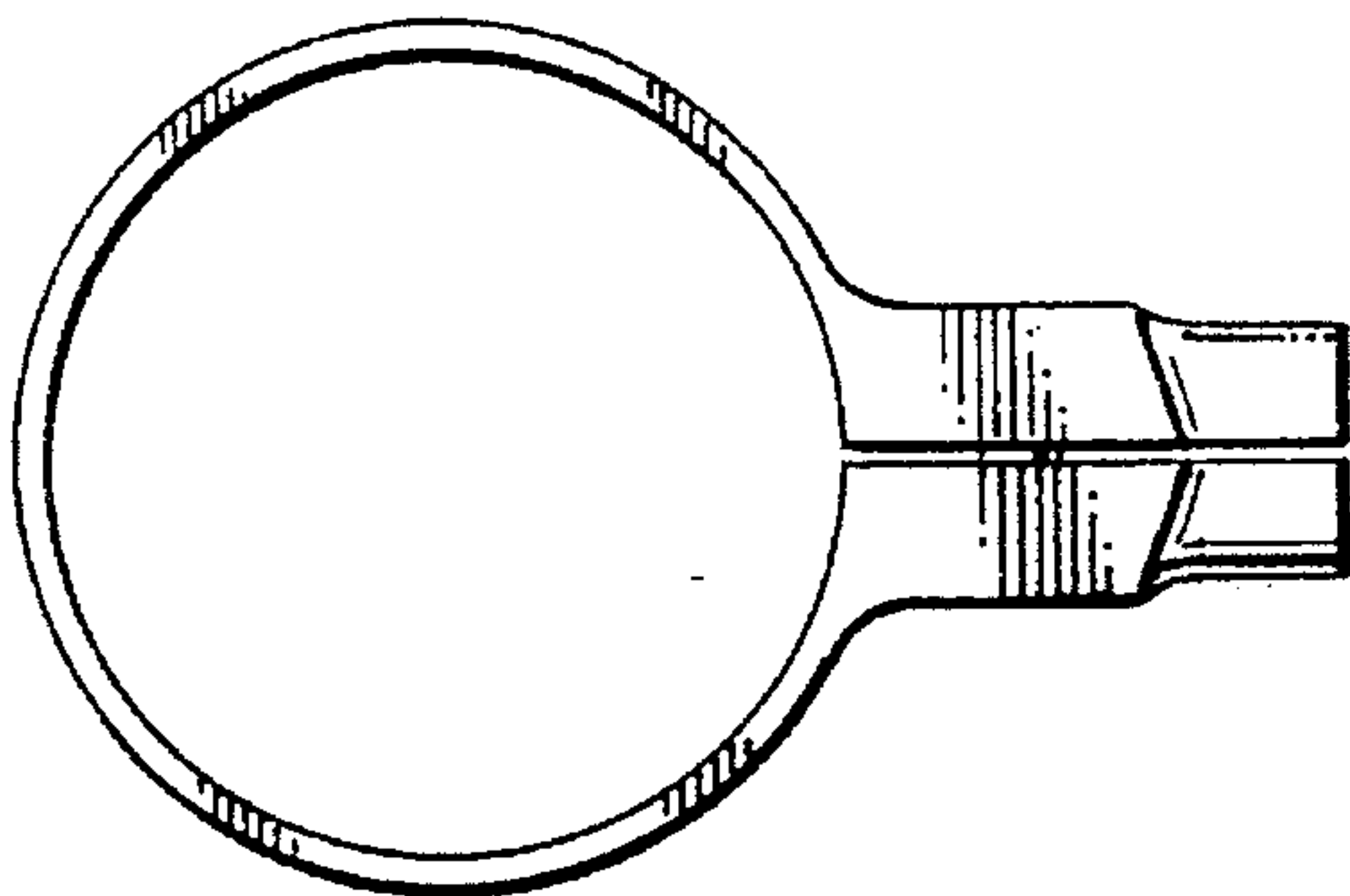

FIG. 4



FIG. 5

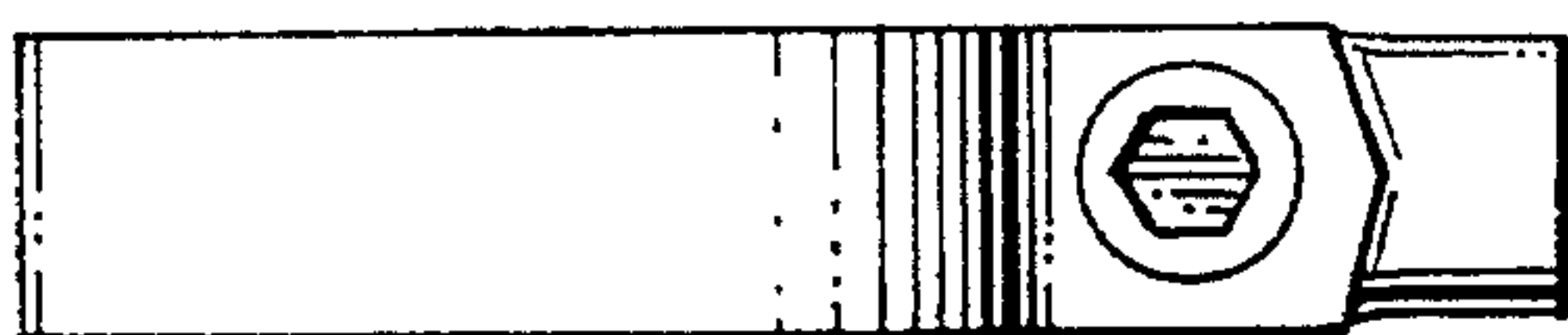

FIG. 6

