



US00D378508S

United States Patent [19]

[11] Patent Number: **Des. 378,508**

Kinthead

[45] Date of Patent: ****Mar. 18, 1997**

[54] **SET OF BOAT BUMPER**

DESCRIPTION

[76] Inventor: **Alan Kinthead**, 4650 W. Route K.,
Columbia, Mo. 65203

[**] Term: **14 Years**

[21] Appl. No.: **53,209**

[22] Filed: **Apr. 17, 1996**

[52] U.S. Cl. **D12/317**

[58] Field of Search D12/317, 318;
114/219, 343, 361

FIG. 1 is a side elevational view of a set of boat bumper showing my new design, the broken lines are for illustrative purposes only and form no part of the claimed design;

FIG. 2 is a front view of the boat bumper shown in the front portion of the boat;

FIG. 3 is a side elevational view of FIG. 2;

FIG. 4 is a top plan view of FIG. 2;

FIG. 5 is a bottom plan view of FIG. 2;

FIG. 6 is a rear view of FIG. 2;

FIG. 7 is a front view of the boat bumper shown in the middle portion of the boat;

FIG. 8 is a side elevational view of FIG. 7;

FIG. 9 is a top plan view of FIG. 7;

FIG. 10 is a bottom plan view of FIG. 7;

FIG. 11 is a rear view of FIG. 7;

FIG. 12 is a front view of the boat bumper shown in the rear portion of the boat;

FIG. 13 is a side elevational view of FIG. 12;

FIG. 14 is a top plan view of FIG. 12;

FIG. 15 is a bottom plan view of FIG. 12; and,

FIG. 16 is a rear view of FIG. 12.

[56] **References Cited**

U.S. PATENT DOCUMENTS

D. 368,063	3/1996	Newton	D12/317
D. 370,657	6/1996	Block, Jr.	D12/317
4,751,891	6/1988	Wilson	114/219
4,972,791	11/1990	Williams	114/219

Primary Examiner—Kay H. Chin

[57] **CLAIM**

The ornamental design for a set of boat bumper, as shown and described.

1 Claim, 4 Drawing Sheets

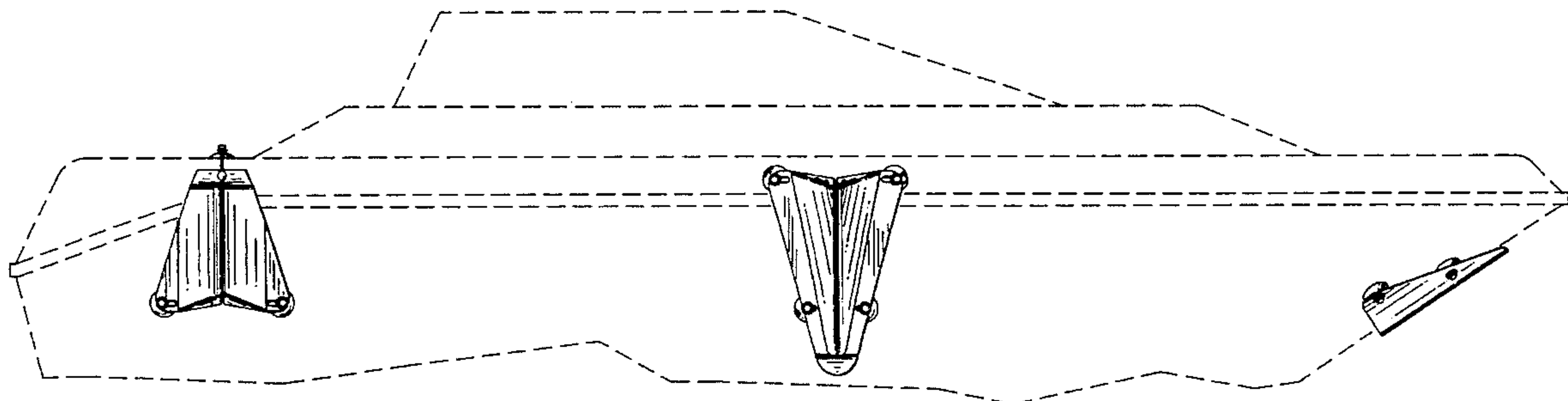

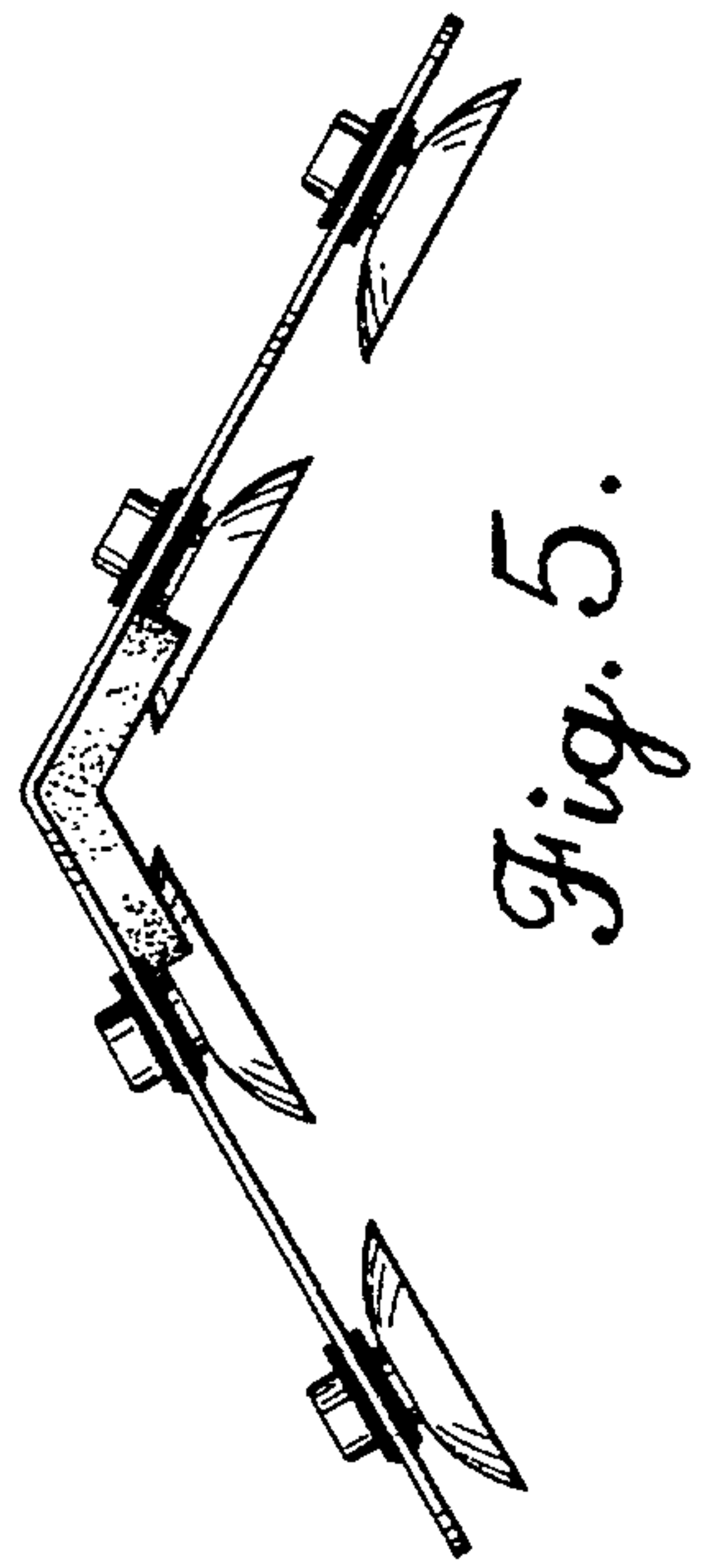
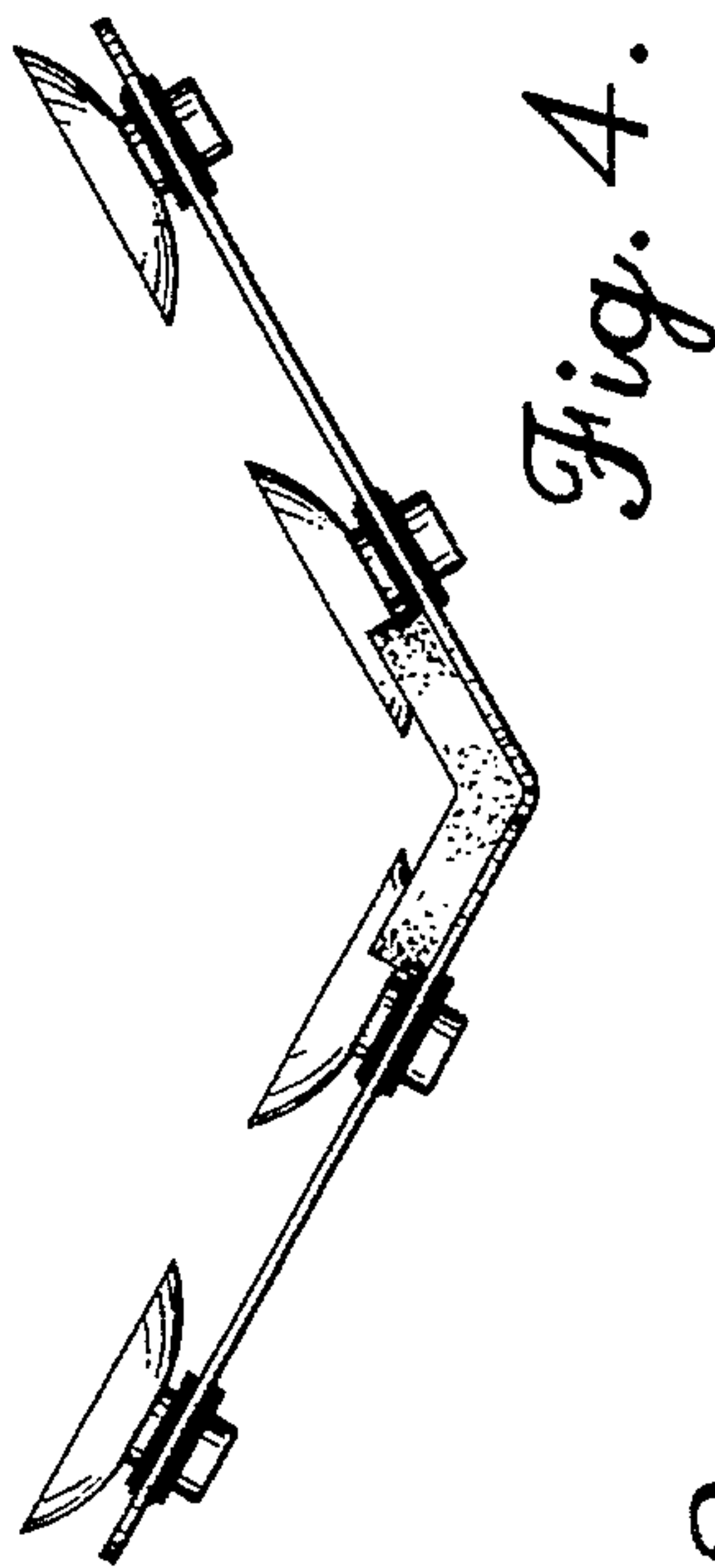
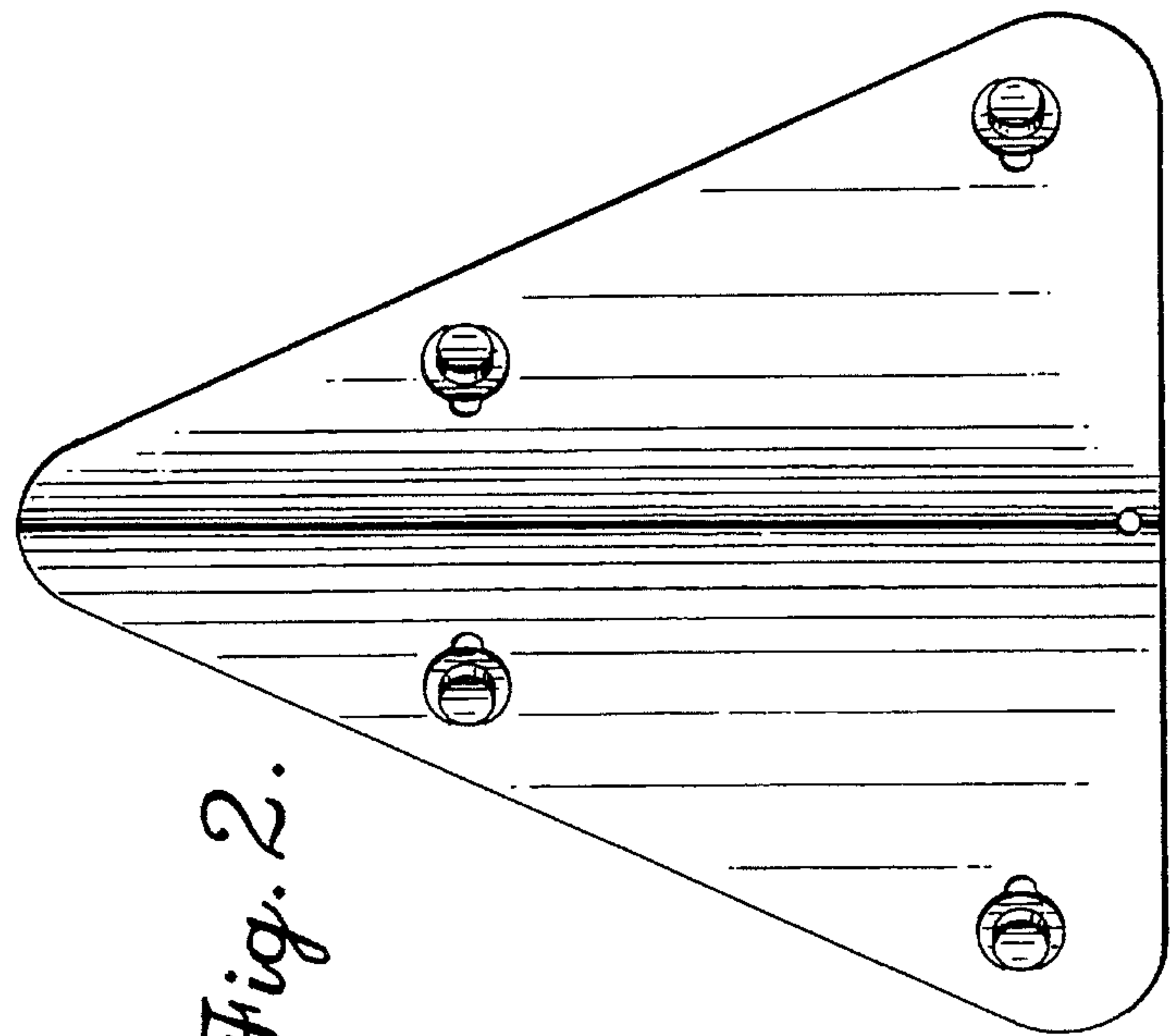
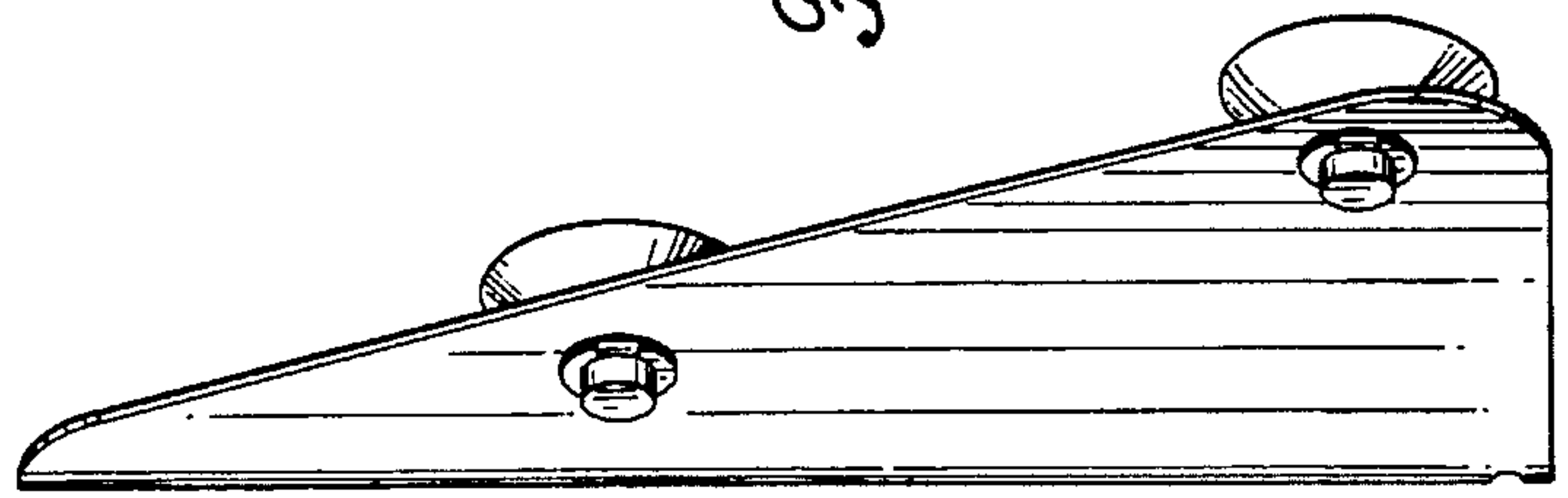
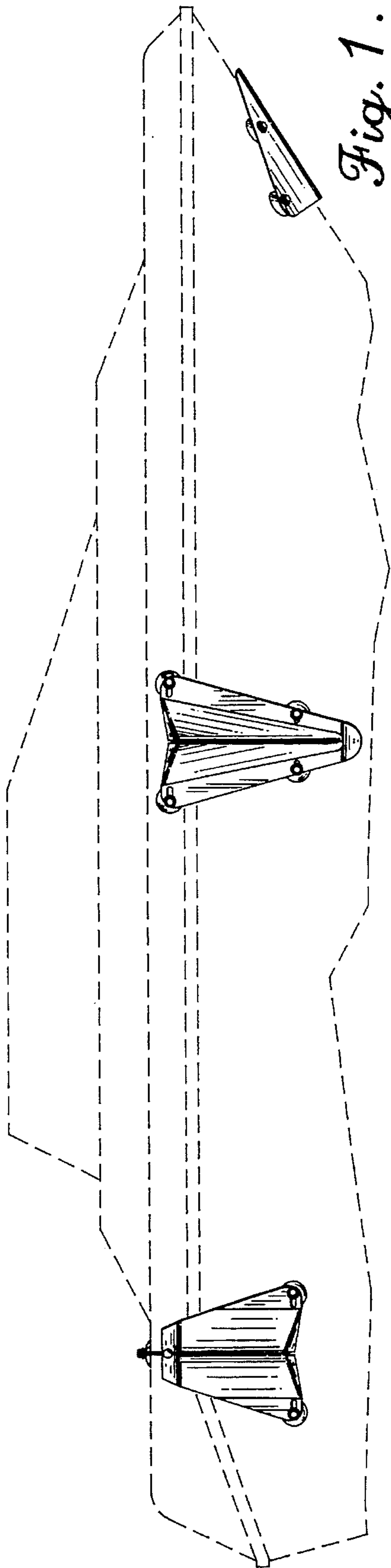

Fig. 2.

Fig. 1.

Fig. 4.

Fig. 3.

Fig. 5.

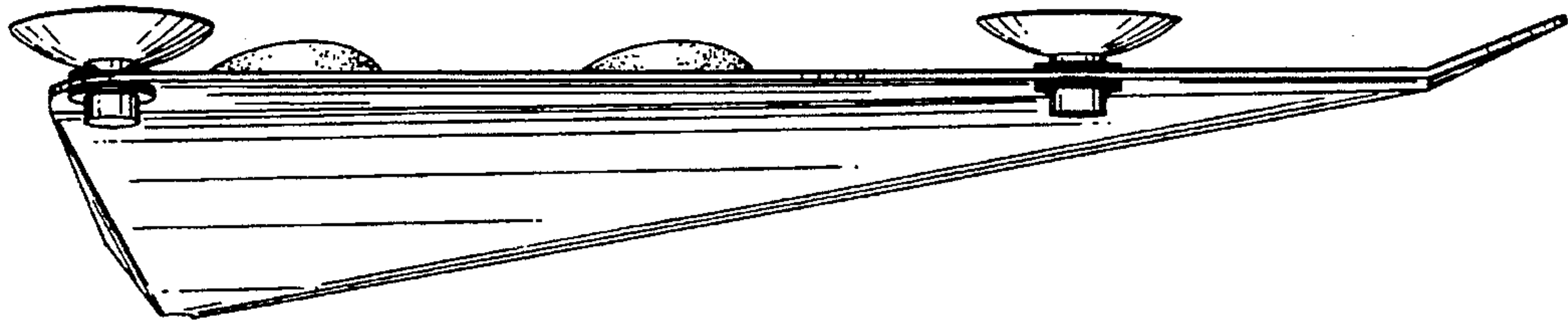

Fig. 8.

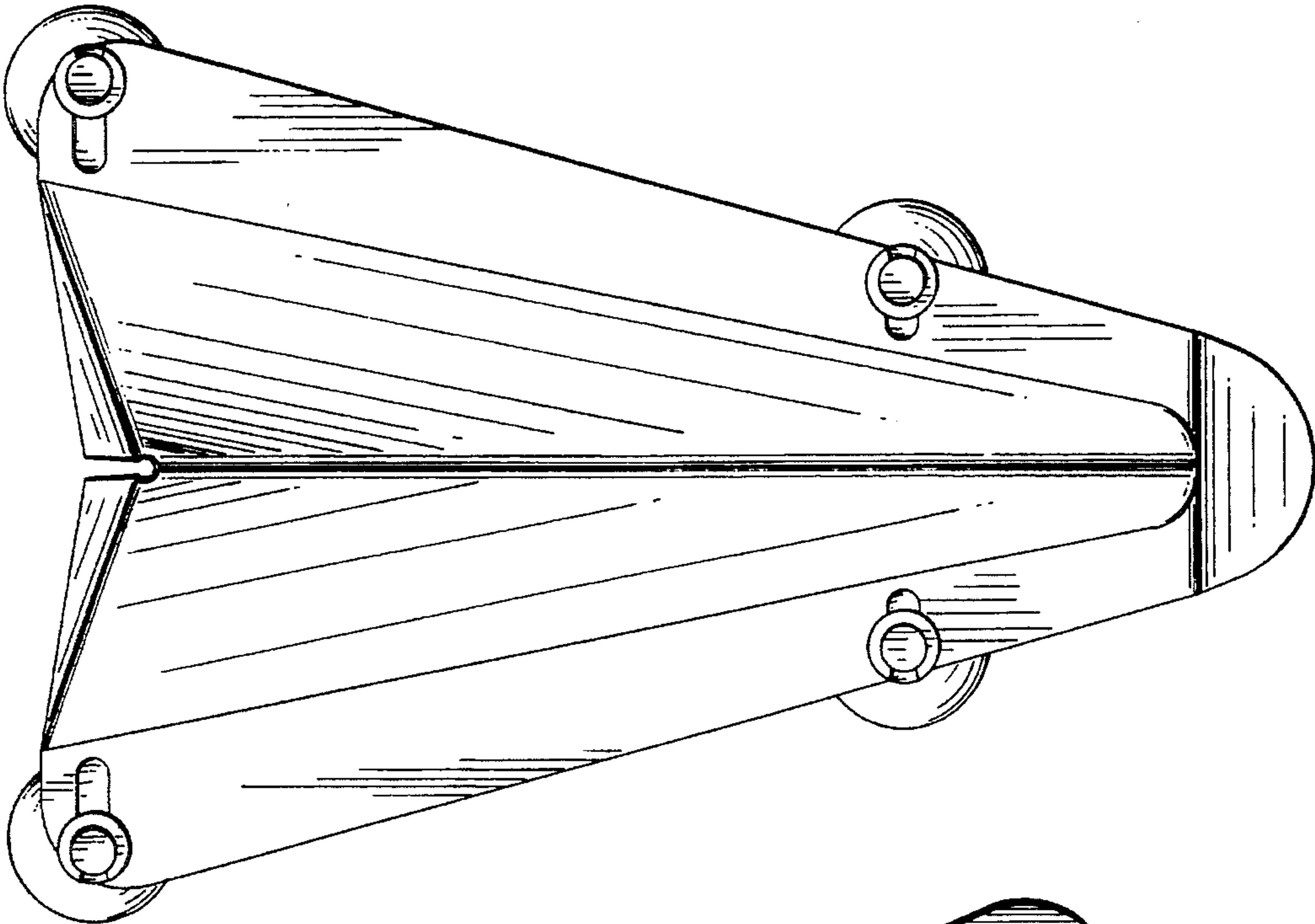

Fig. 7.

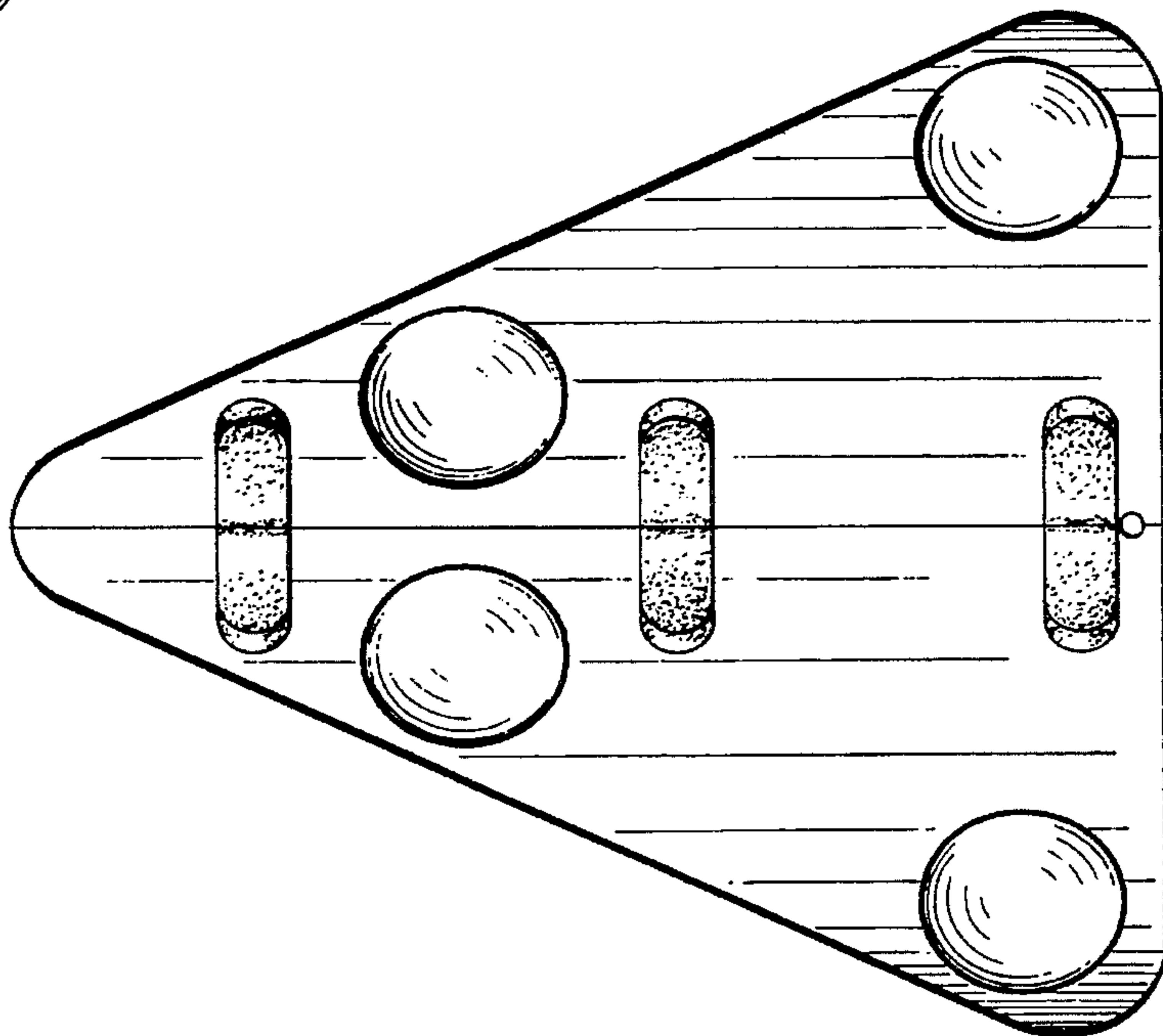

Fig. 6.

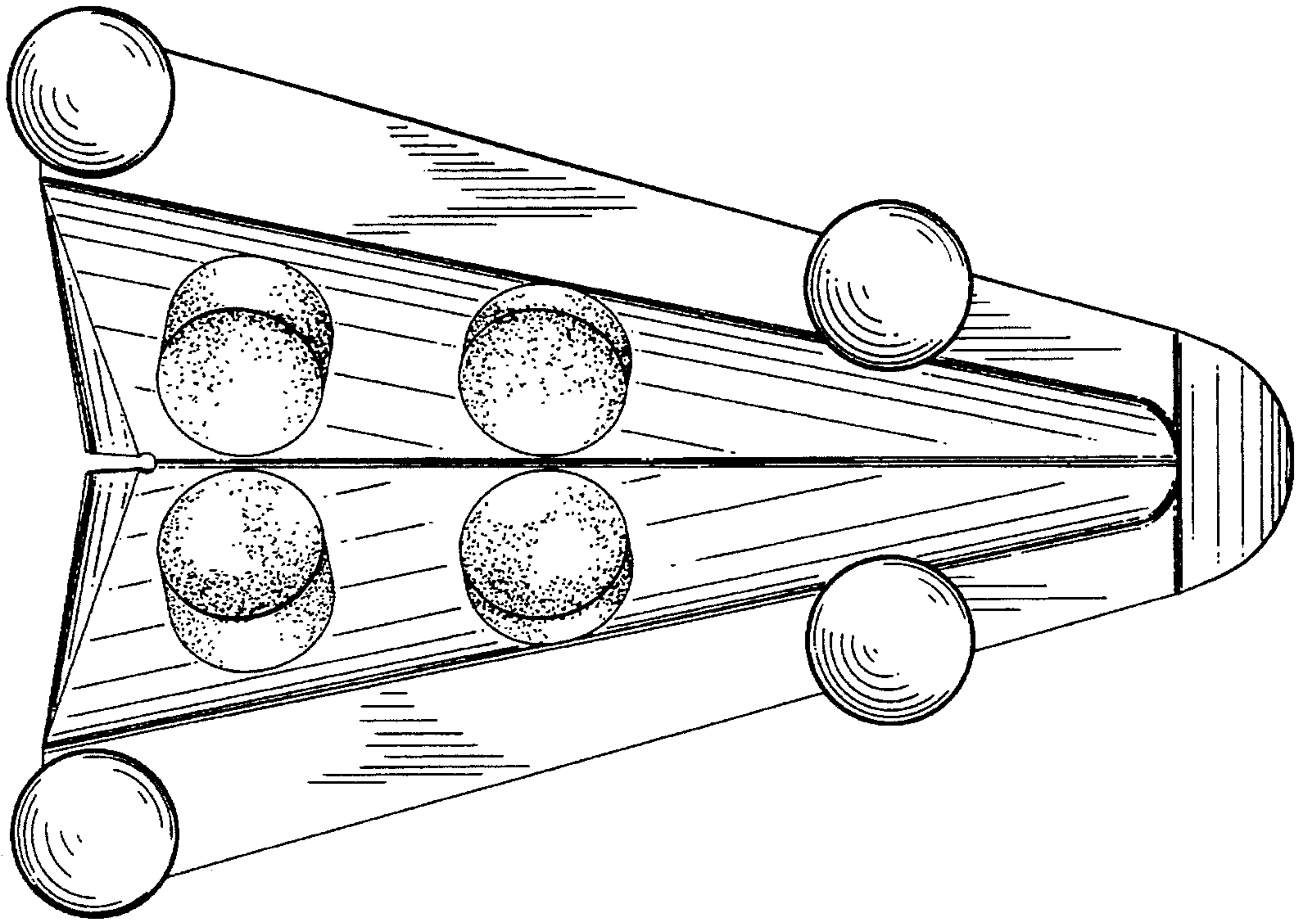

Fig. 11.

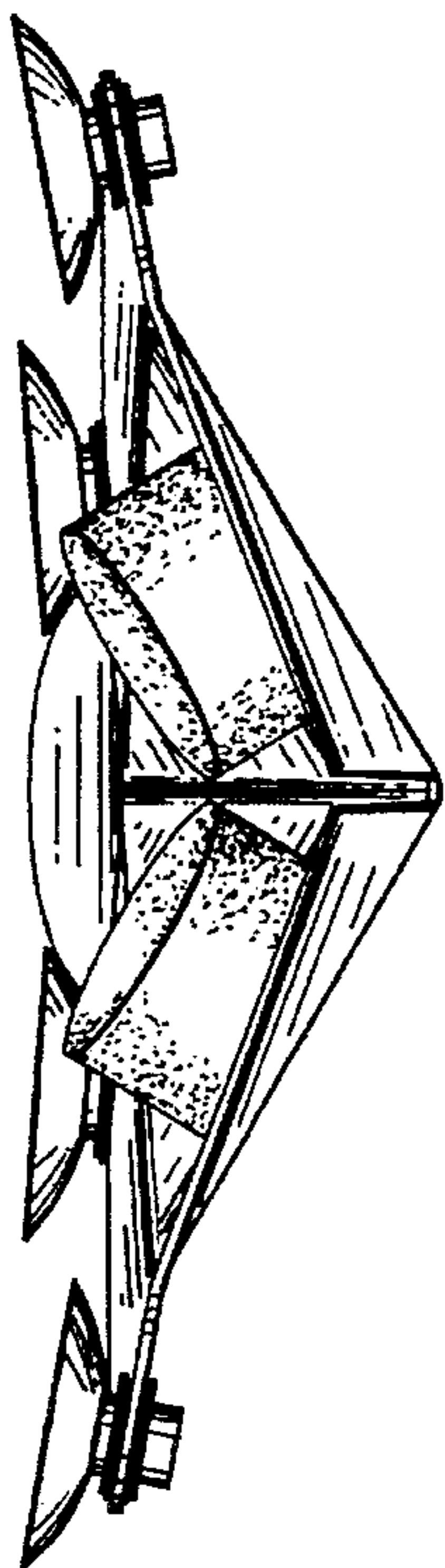

Fig. 9.

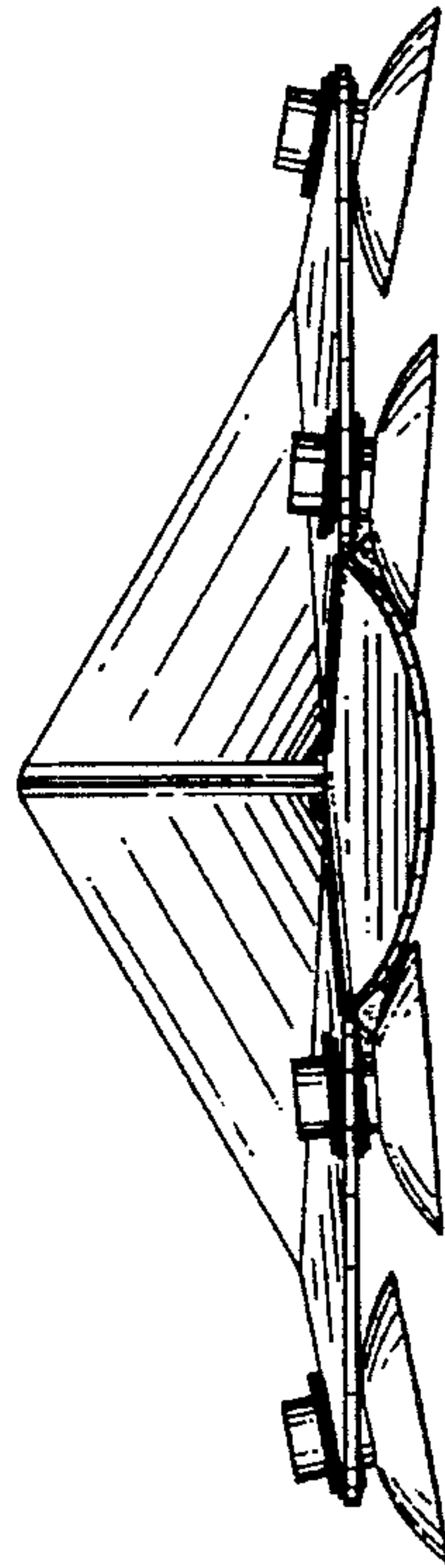

Fig. 10.

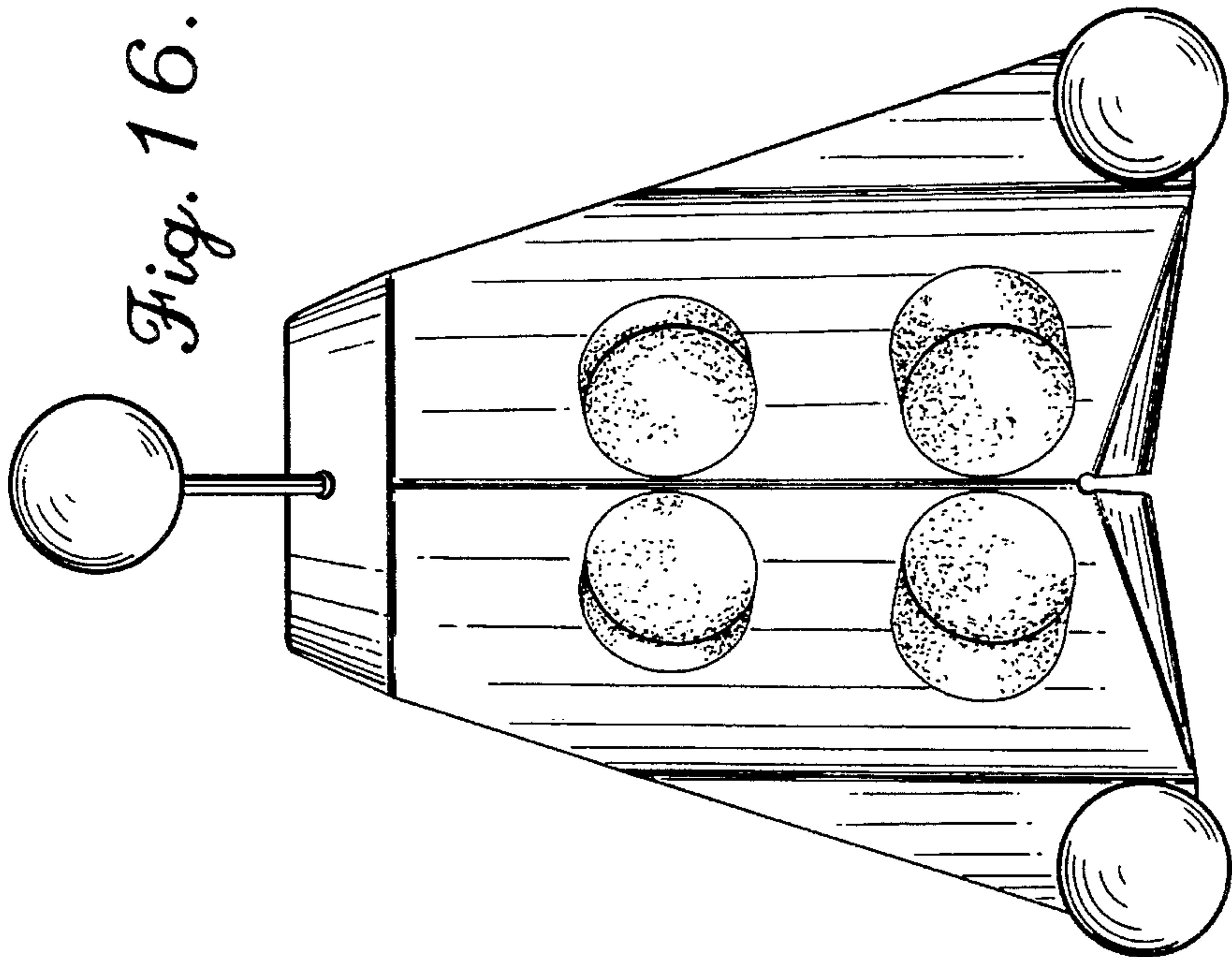

Fig. 16.

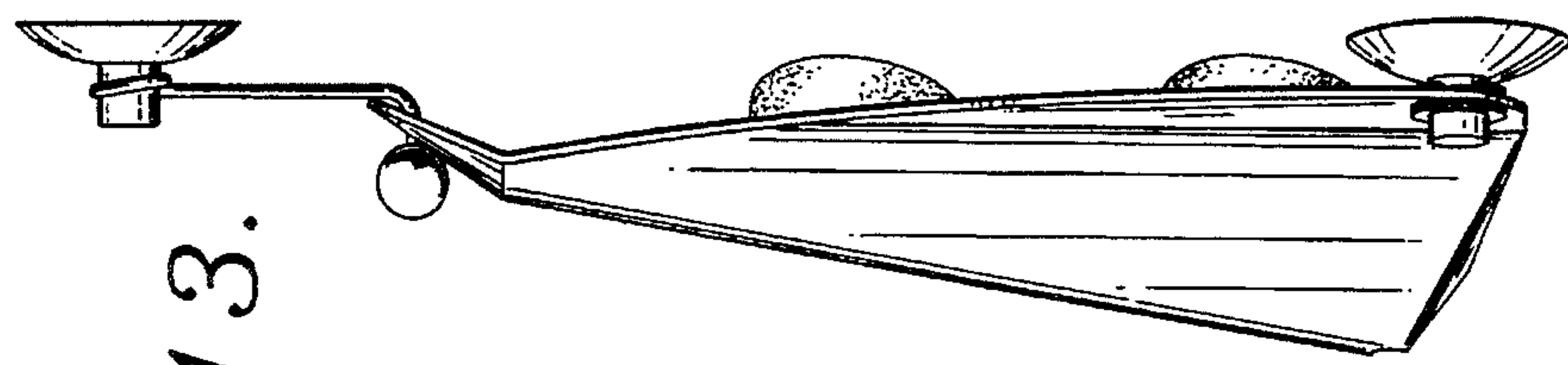

Fig. 13.

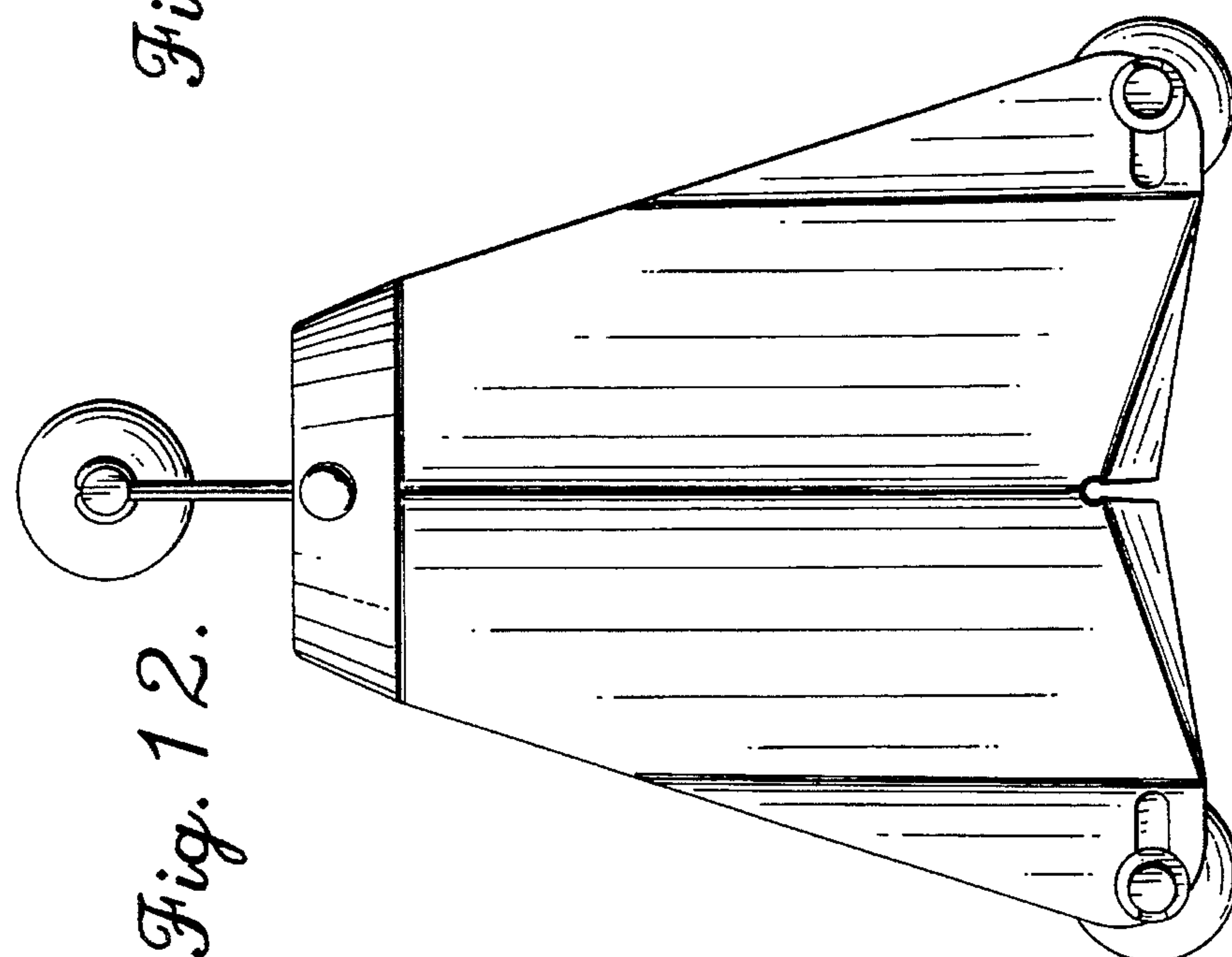

Fig. 12.

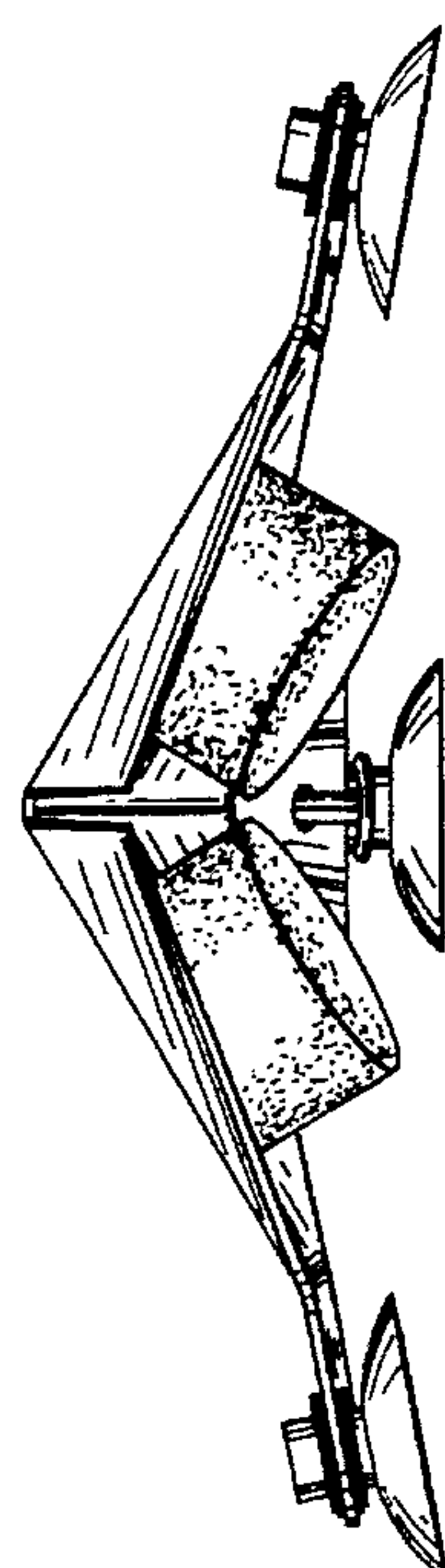

Fig. 15.

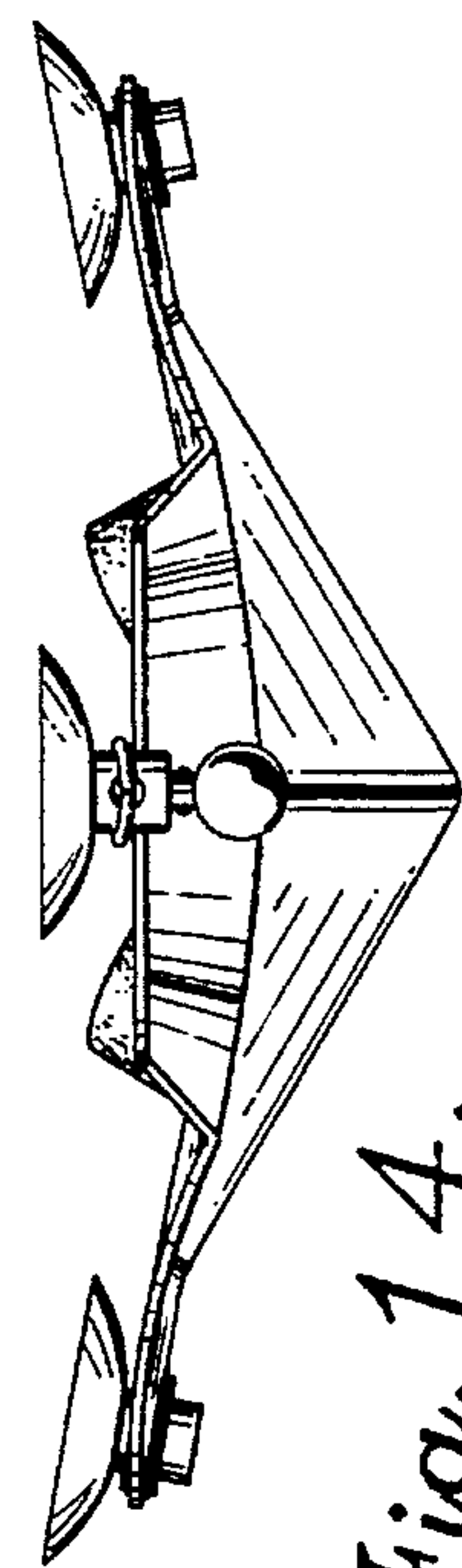

Fig. 14.