



US00D378283S

United States Patent [19]

[11] Patent Number: **Des. 378,283**

Diehl

[45] Date of Patent: ****Mar. 4, 1997**

[54] COMPRESSED GAS REGULATOR

[75] Inventor: **Gregory W. Diehl**, Florence, S.C.

[73] Assignee: **The ESAB Group, Inc.**, Florence, S.C.

[**] Term: **14 Years**

[21] Appl. No.: **47,361**

[22] Filed: **Dec. 1, 1995**

[52] U.S. Cl. **D10/85**

[58] Field of Search D10/85; 73/431,
73/714; 137/69, 71, 505.42, 505.11, 557,
559, 906; 169/58, 70

[56] References Cited

U.S. PATENT DOCUMENTS

856,989	6/1907	Schultz, Jr.	137/505.42 X
2,595,156	4/1952	Matasovic	73/714
2,768,643	10/1956	Acomb .	
2,918,081	12/1959	Laver, Jr.	137/505.11
3,926,208	12/1975	Hoffman et al. .	
4,915,127	4/1990	Werley	137/505.42
5,022,435	6/1991	Jaw-Shiunn .	

Primary Examiner—Antoine Duval Davis

Attorney, Agent, or Firm—Bell, Seltzer, Park & Gibson, P.A.

[57] CLAIM

The ornamental design for a compressed gas regulator, as shown and described.

DESCRIPTION

FIG. 1 is a perspective view of a compressed gas regulator which embodies the design of the present invention;

FIG. 2 is a side elevation view of the regulator;

FIG. 3 is a top plan view of the regulator;

FIG. 4 is a front elevation view of the regulator, rotated 90° from the orientation shown in FIGS. 1 and 2;

FIG. 5 is a side elevation view of the regulator and illustrating the side opposite that shown in FIG. 2, and rotated 180° from the orientation shown in FIGS. 1 and 2;

FIG. 6 is a rear elevation view of the regulator, rotated 180° from the orientation shown in FIGS. 1 and 2;

FIG. 7 is a bottom plan view of the regulator;

FIG. 8 is a perspective view of a compressed gas regulator which embodies the design of the present invention;

FIG. 9 is a side elevation view of the compressed gas regulator;

FIG. 10 is a top plan view of the compressed gas regulator;

FIG. 11 is a front elevation view of the compressed gas regulator, rotated 90 degrees from the orientation shown in FIGS. 8 and 9;

FIG. 12 is a side elevation view of the compressed gas regulator illustrating the side opposite that shown in FIG. 9, and rotated 180 degrees from the orientation shown in FIGS. 8 and 9;

FIG. 13 is a rear elevation view of the compressed gas regulator, rotated 180 degrees from the orientation shown in FIGS. 8 and 9;

FIG. 14 is a bottom plan view of the compressed gas regulator;

FIG. 15 is a perspective view of a compressed gas regulator which embodies the design of the present invention;

FIG. 16 is a side elevation view of the compressed gas regulator;

FIG. 17 is a top plan view of the compressed gas regulator;

FIG. 18 is a front elevation view of the compressed gas regulator, rotated 90 degrees from the orientation shown in FIGS. 15 and 16;

FIG. 19 is a side elevation view of the compressed gas regulator illustrating the side opposite that shown in FIG. 16, and rotated 180 degrees from the orientation shown in FIGS. 15 and 16;

FIG. 20 is a rear elevation view of the compressed gas regulator, rotated 180 degrees from the orientation shown in FIGS. 15 and 16; and,

FIG. 21 is a bottom plan view of the compressed gas regulator.

1 Claim, 6 Drawing Sheets

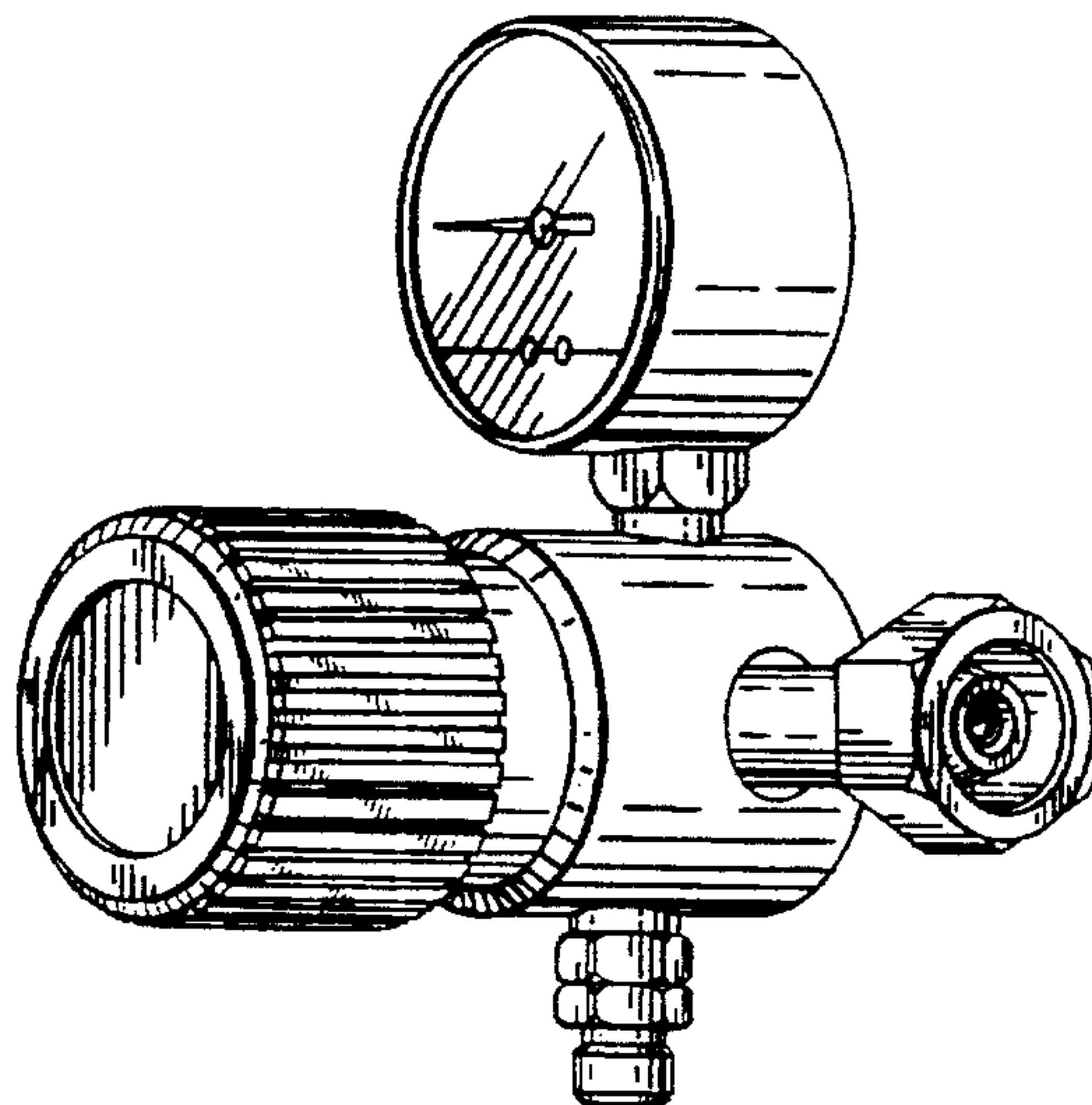

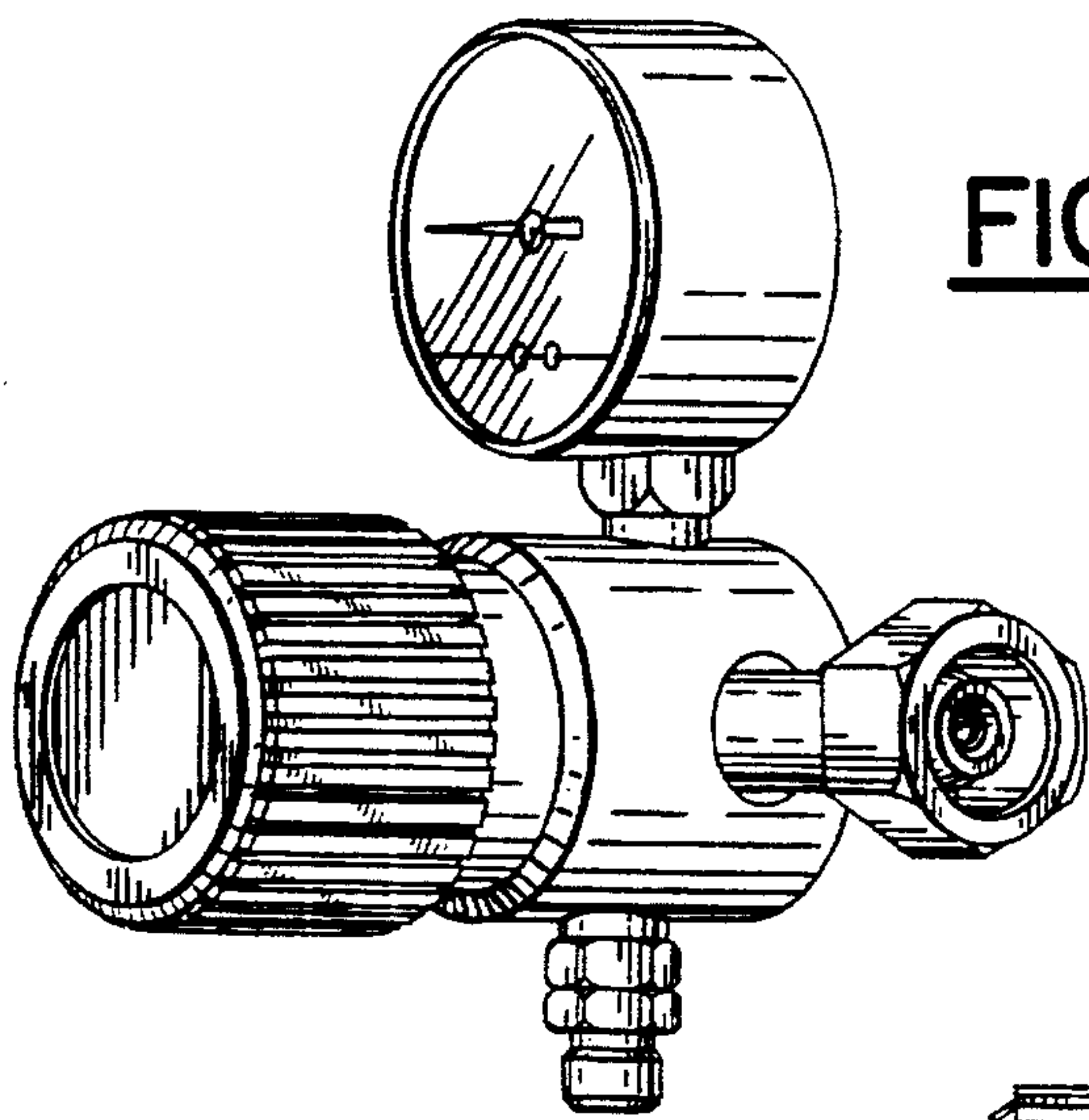

FIG. 1.

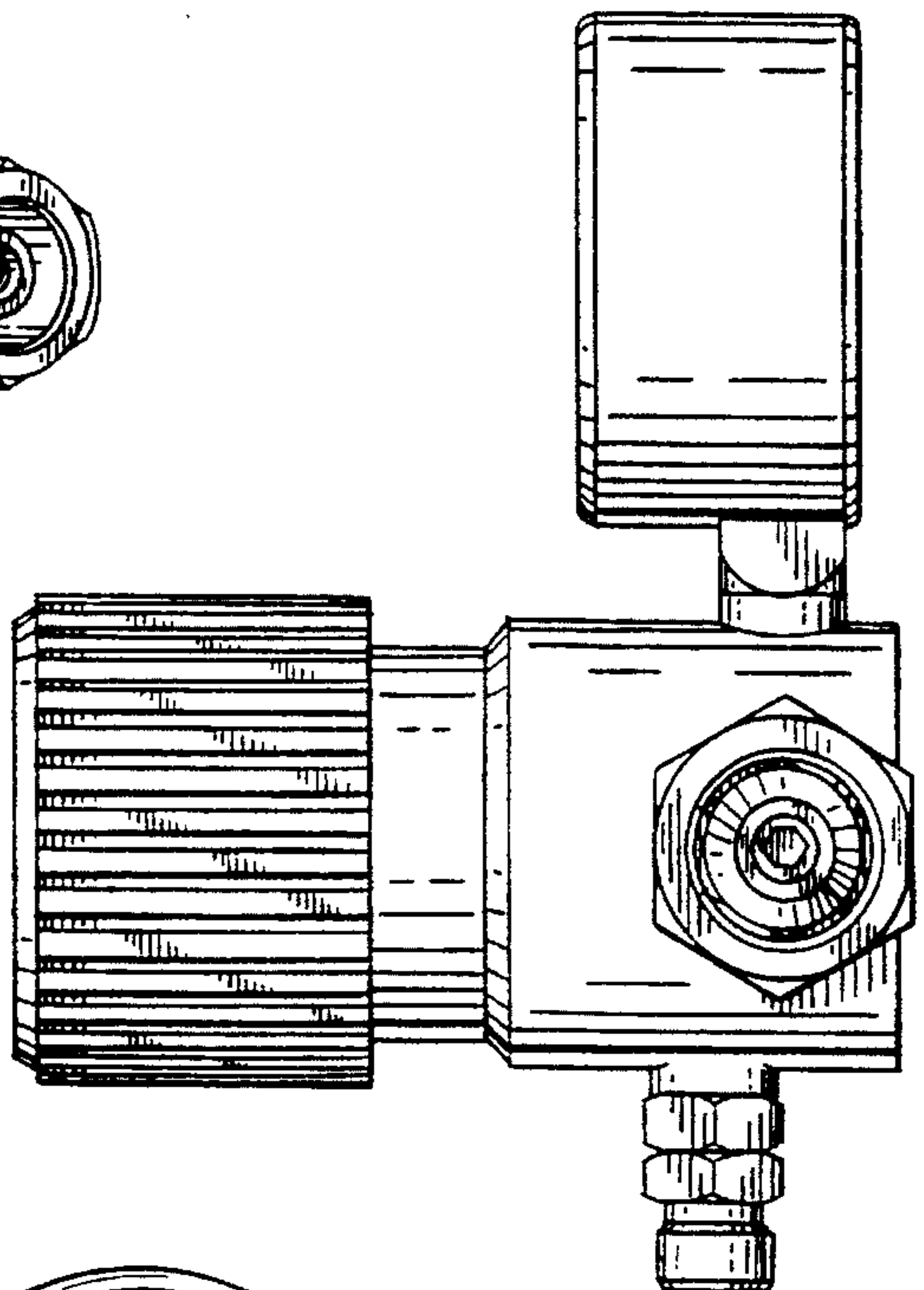

FIG. 2.

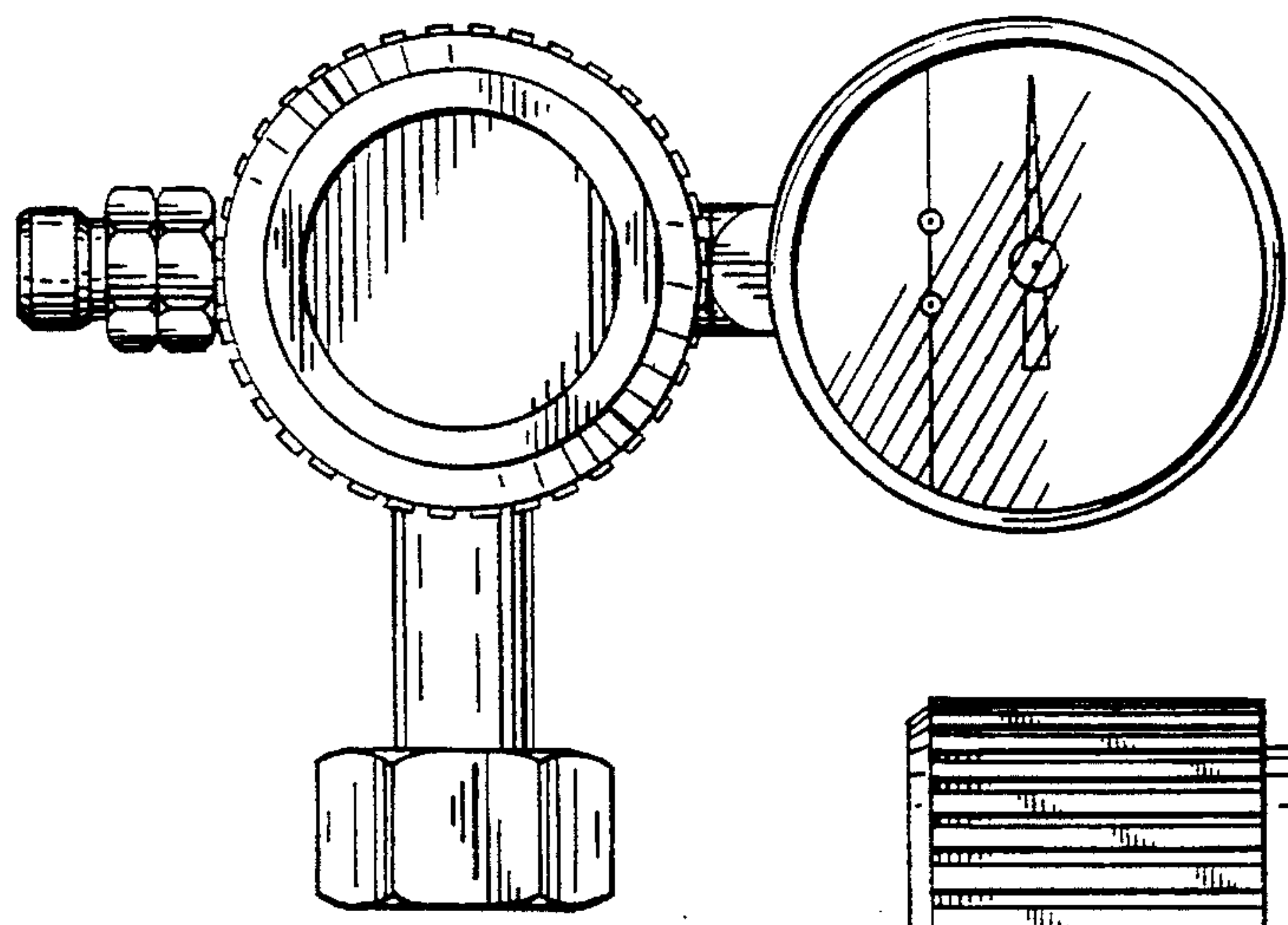

FIG. 4.

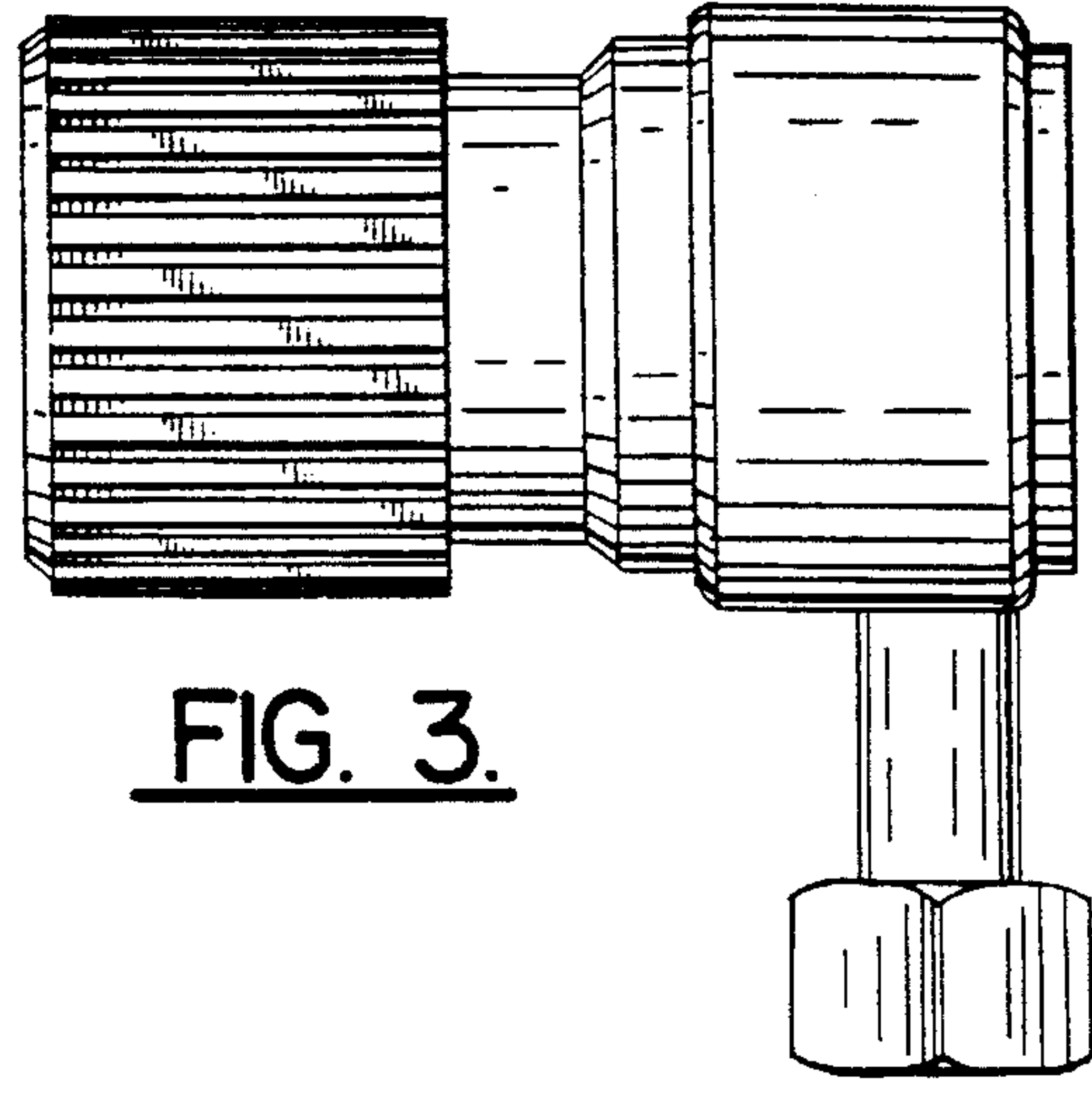

FIG. 3.

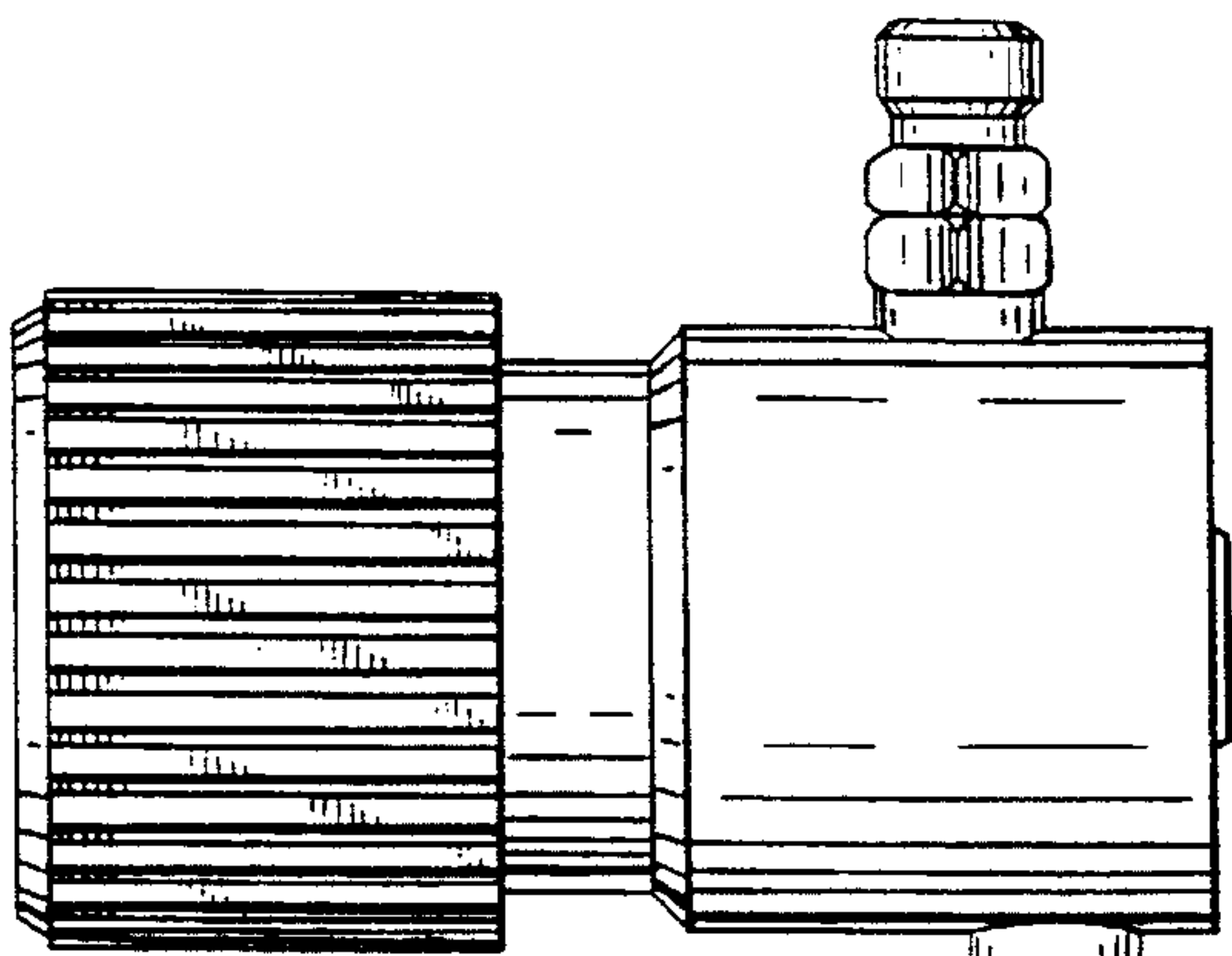

FIG. 5.

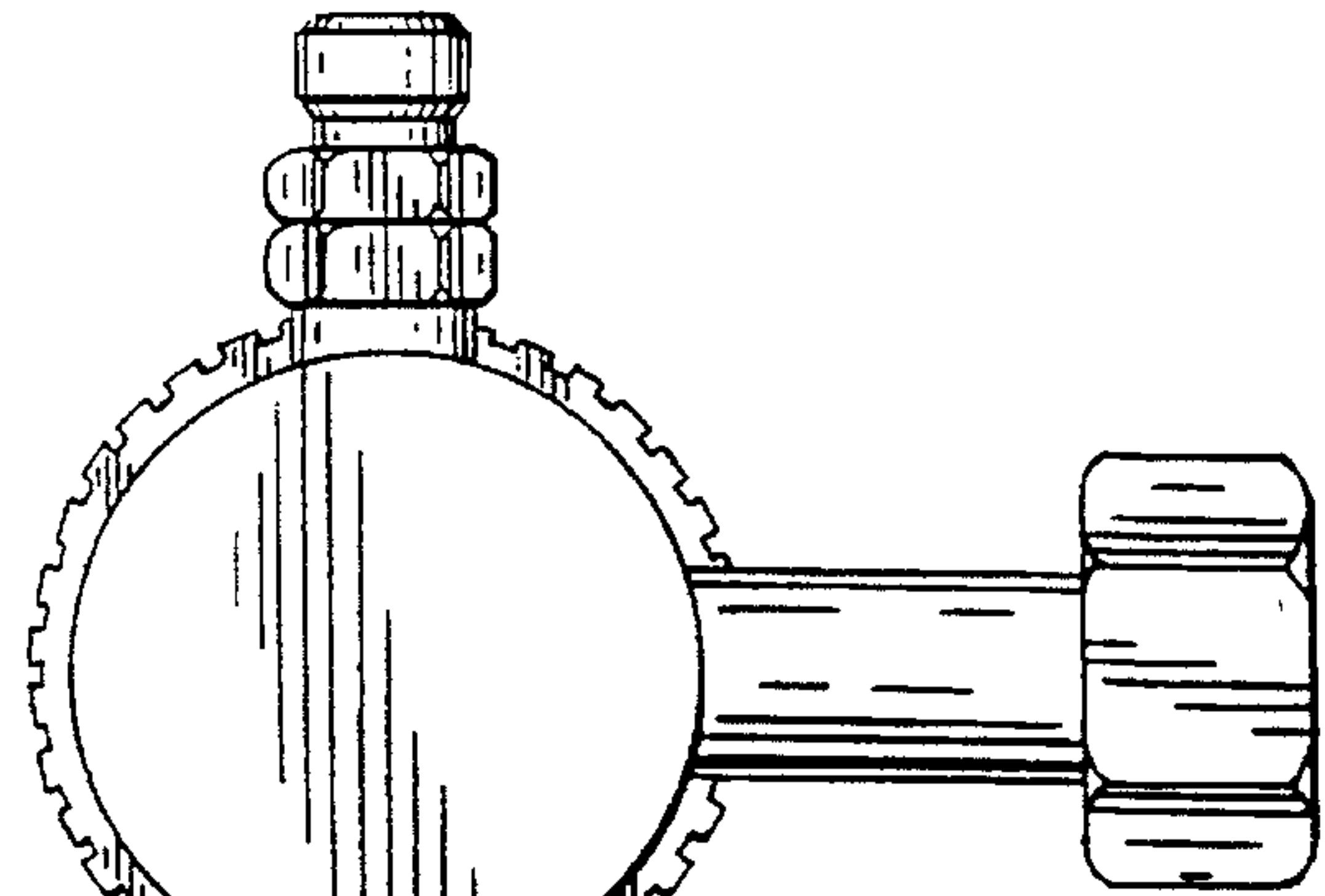
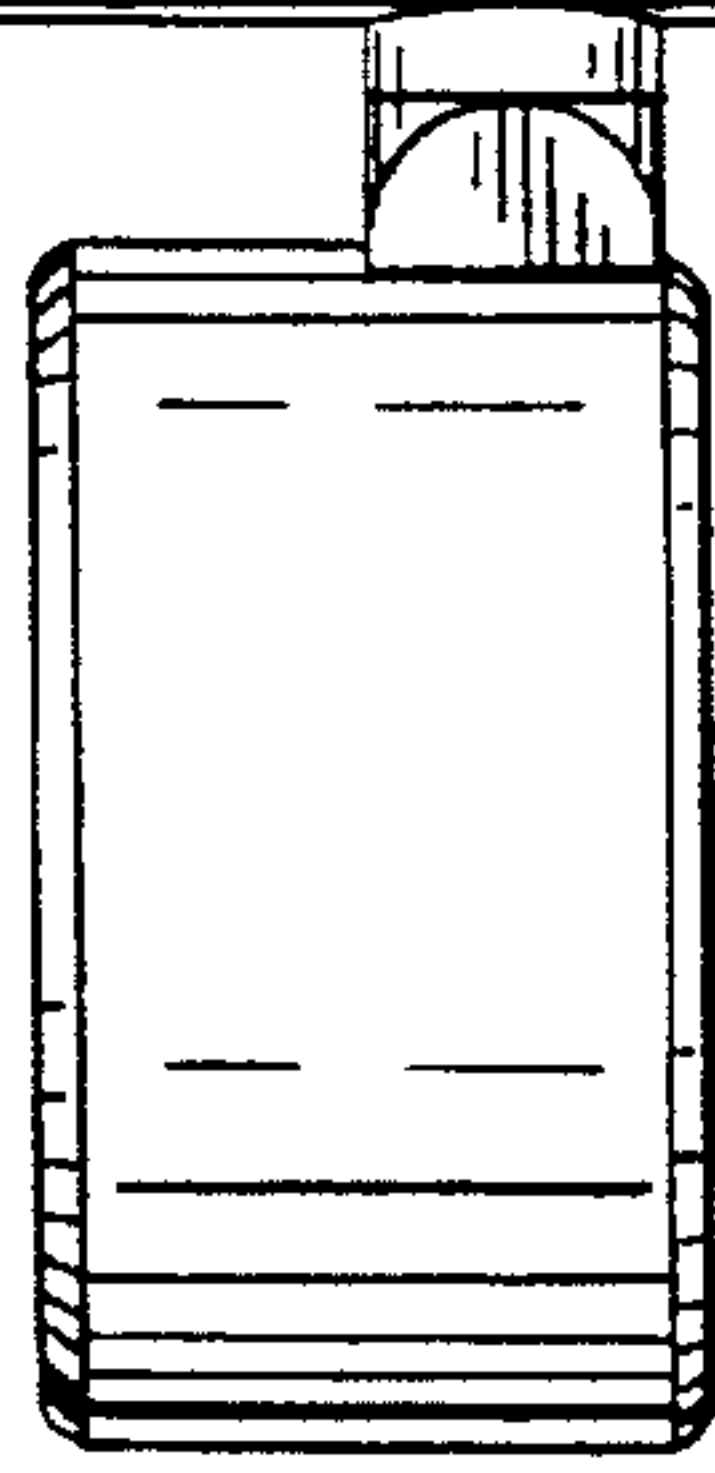

FIG. 6.

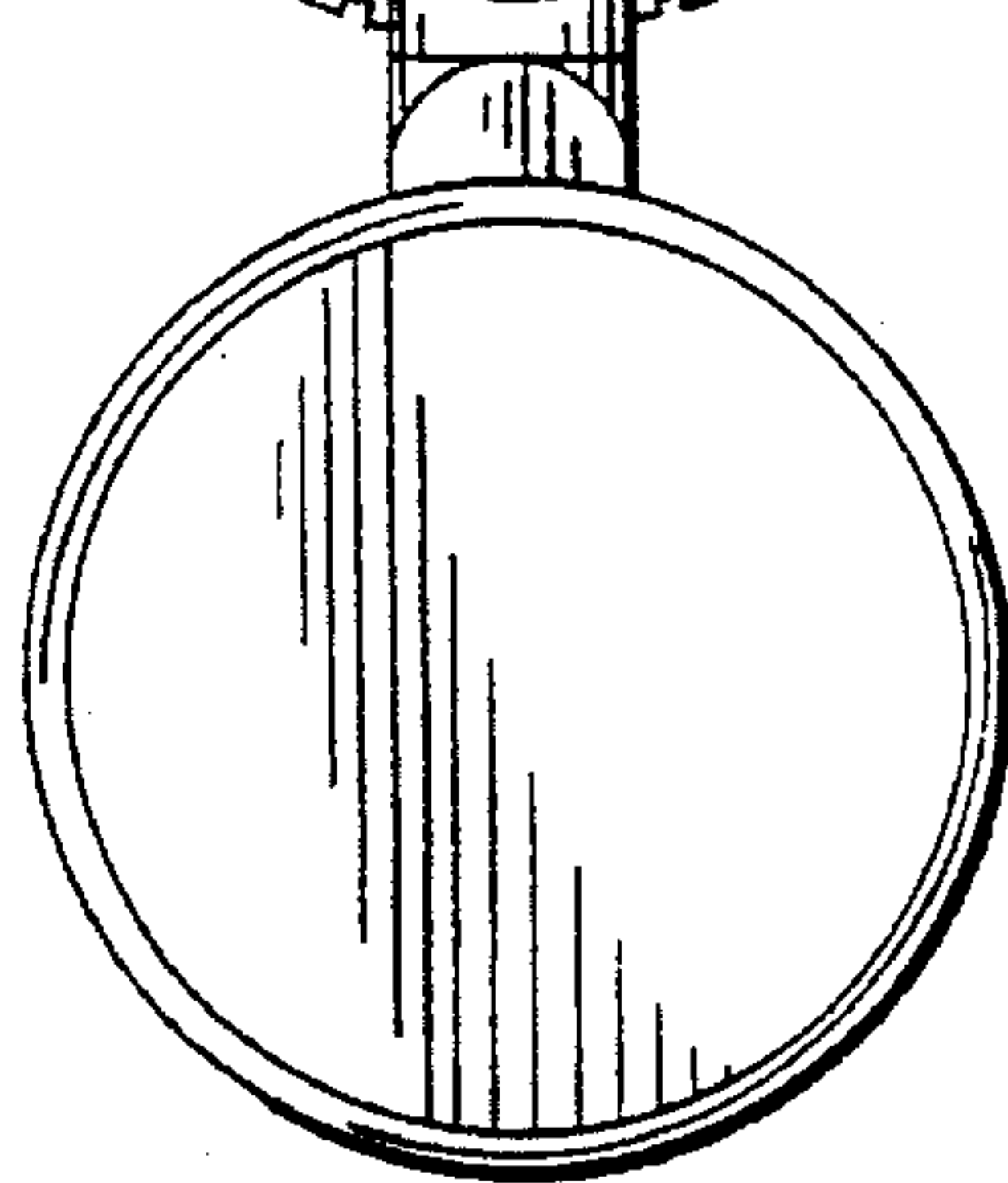
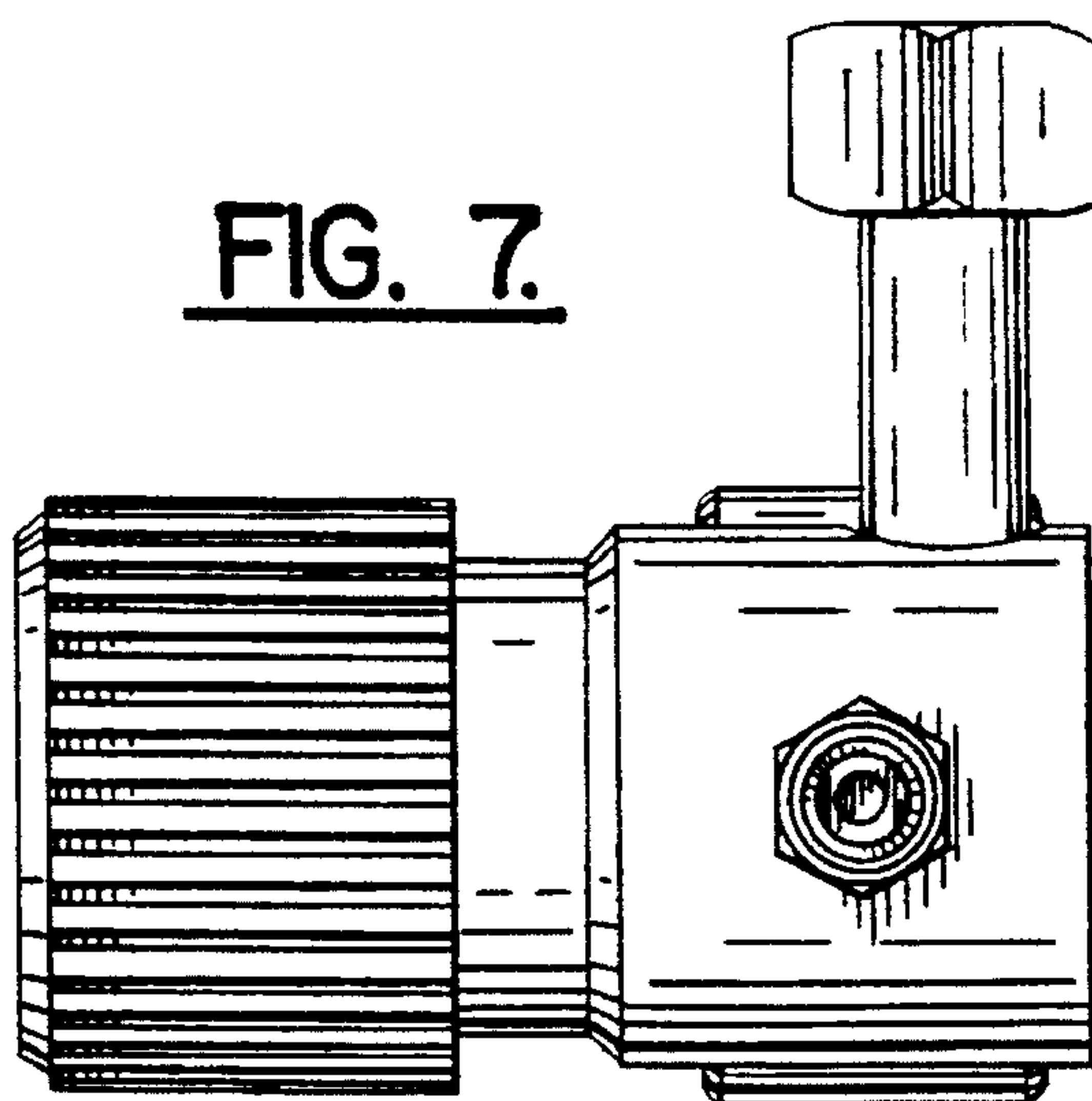

FIG. 7.



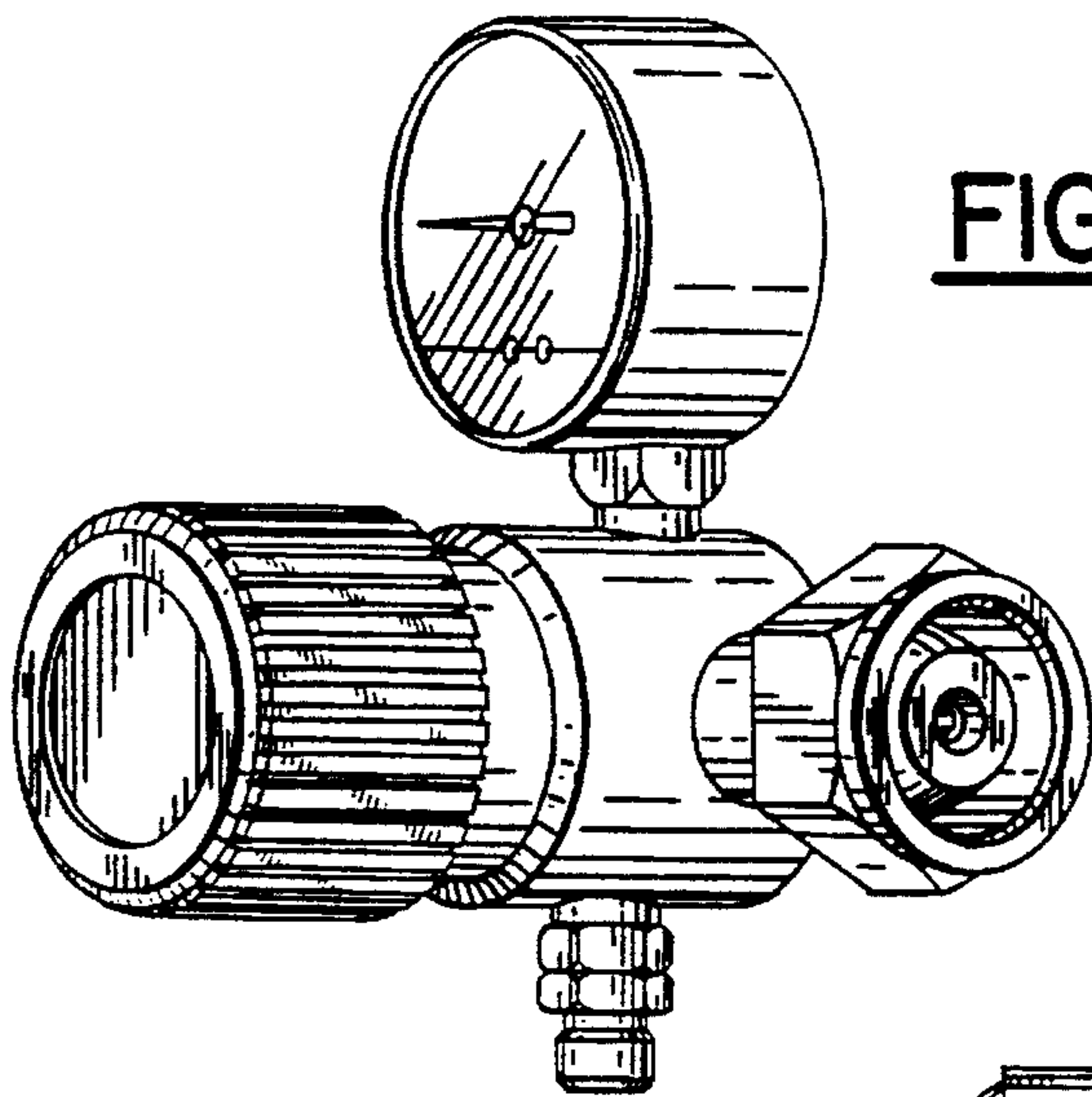

FIG. 8.

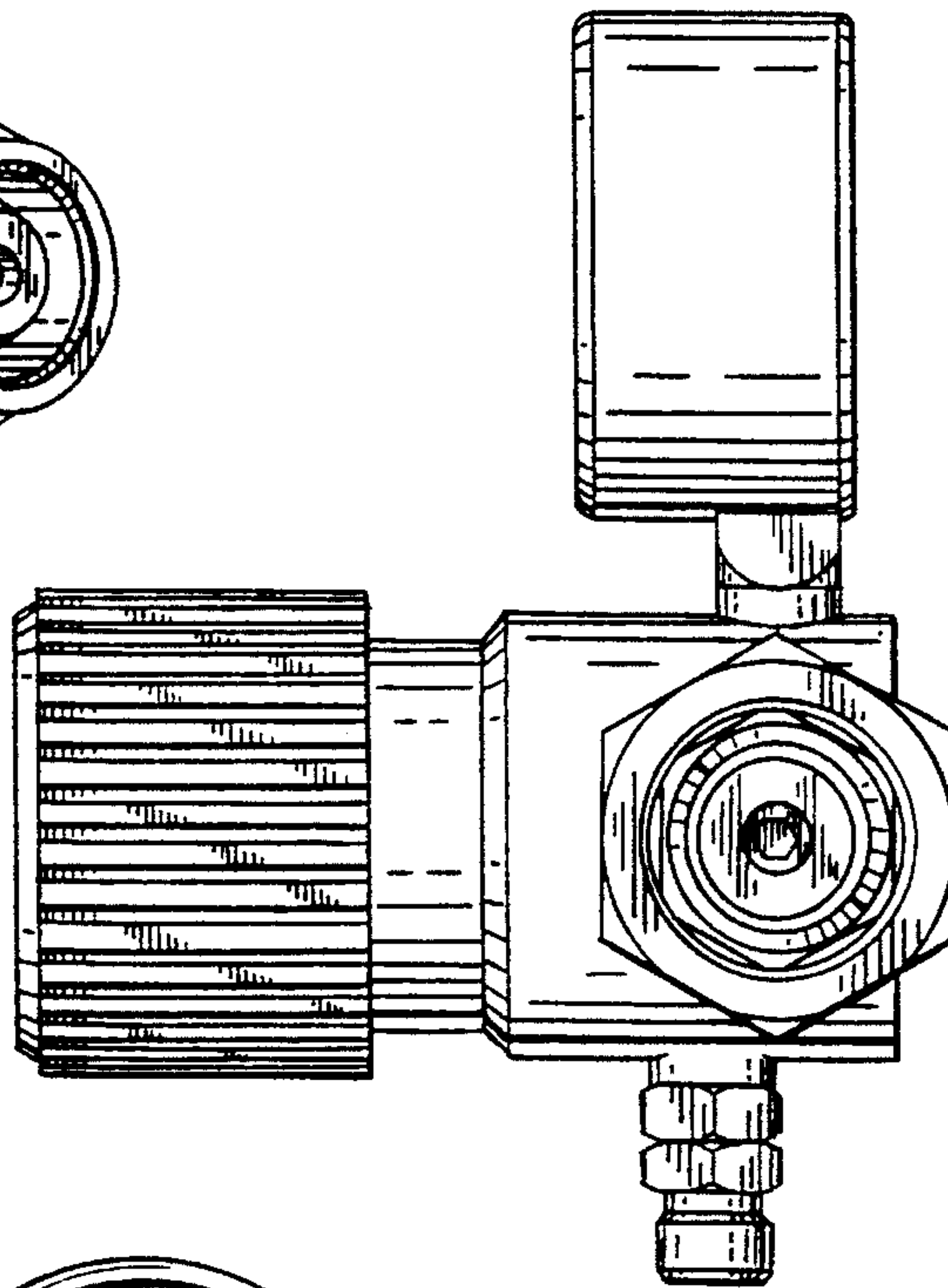

FIG. 9.

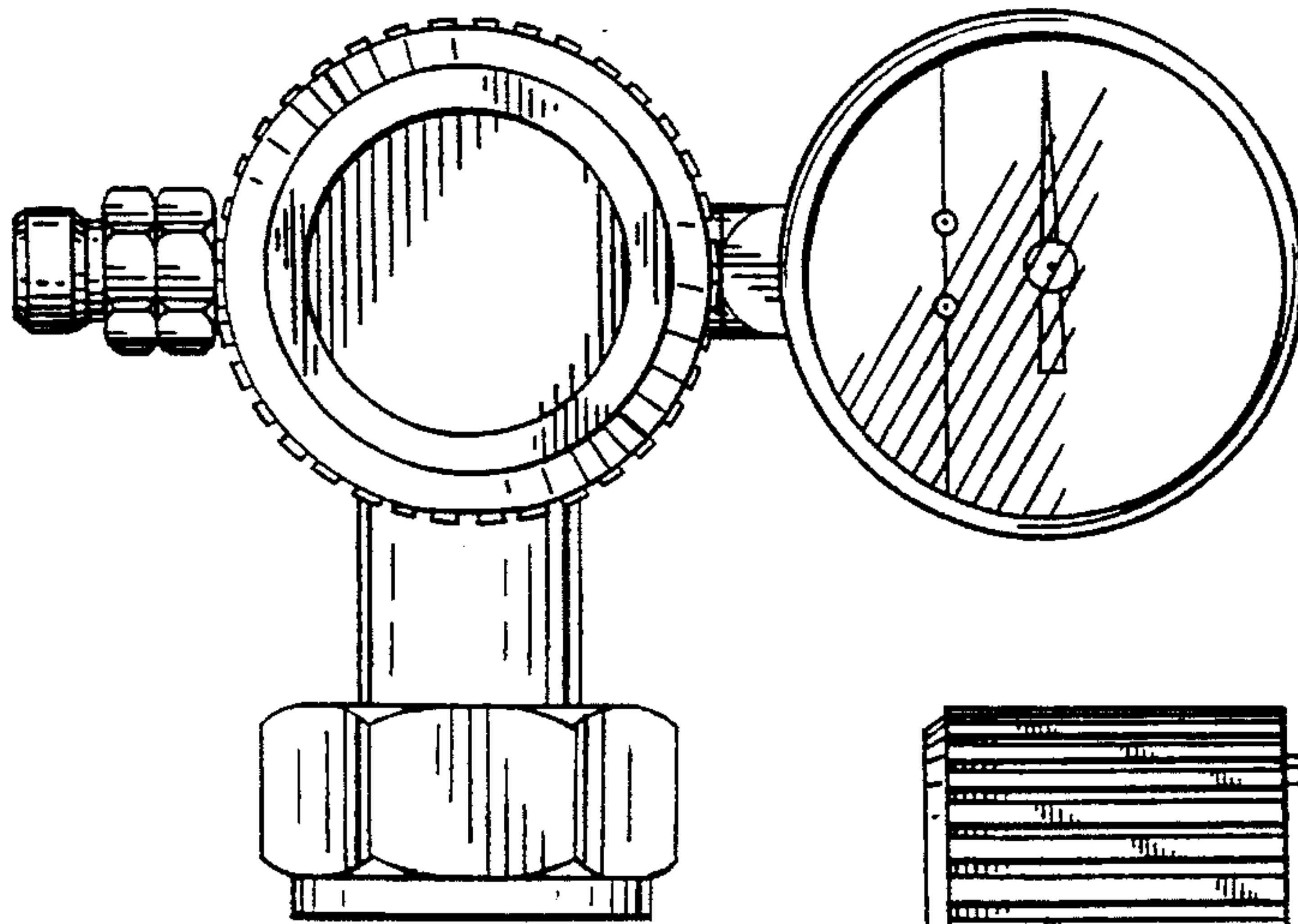

FIG. 11.

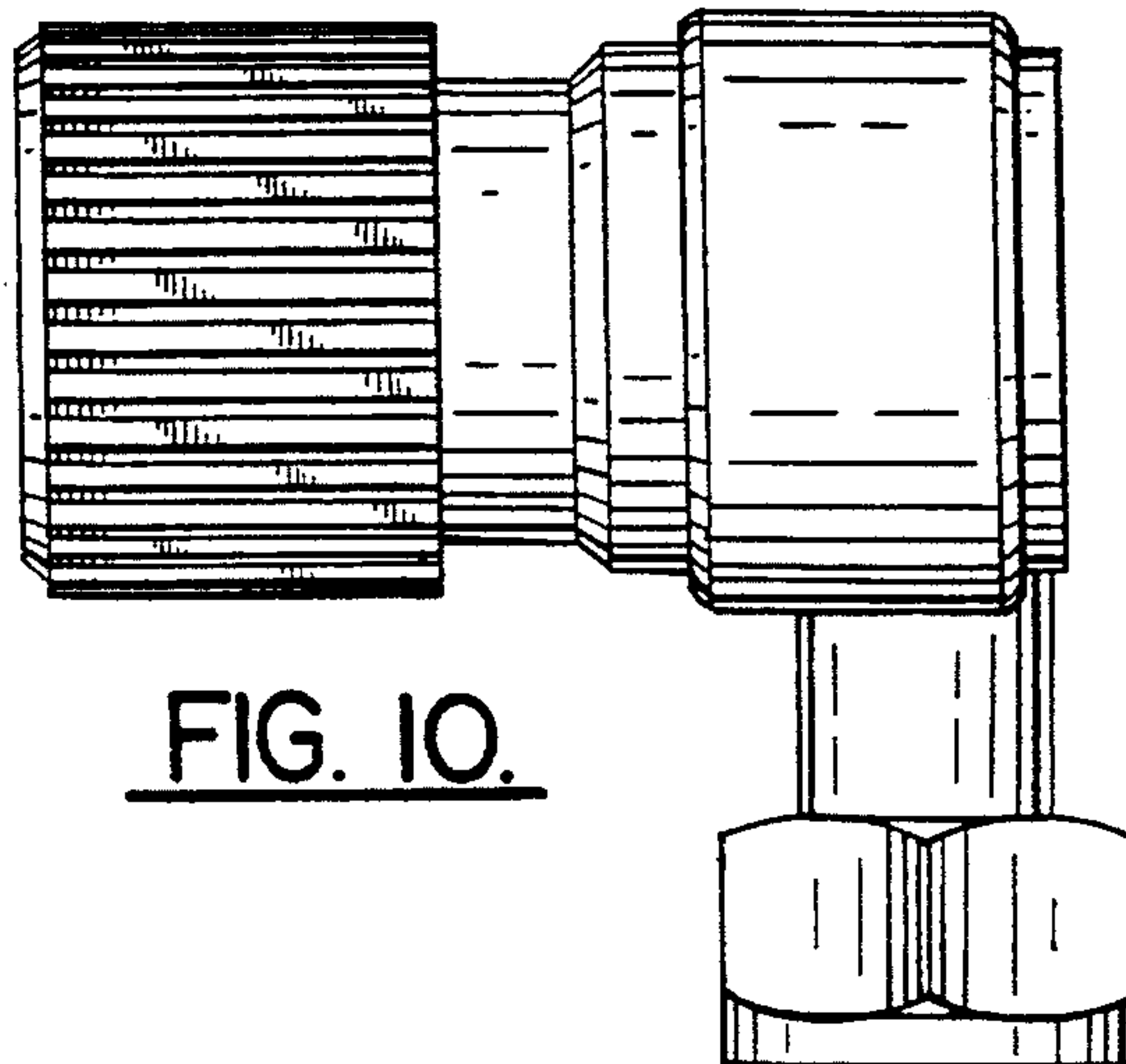
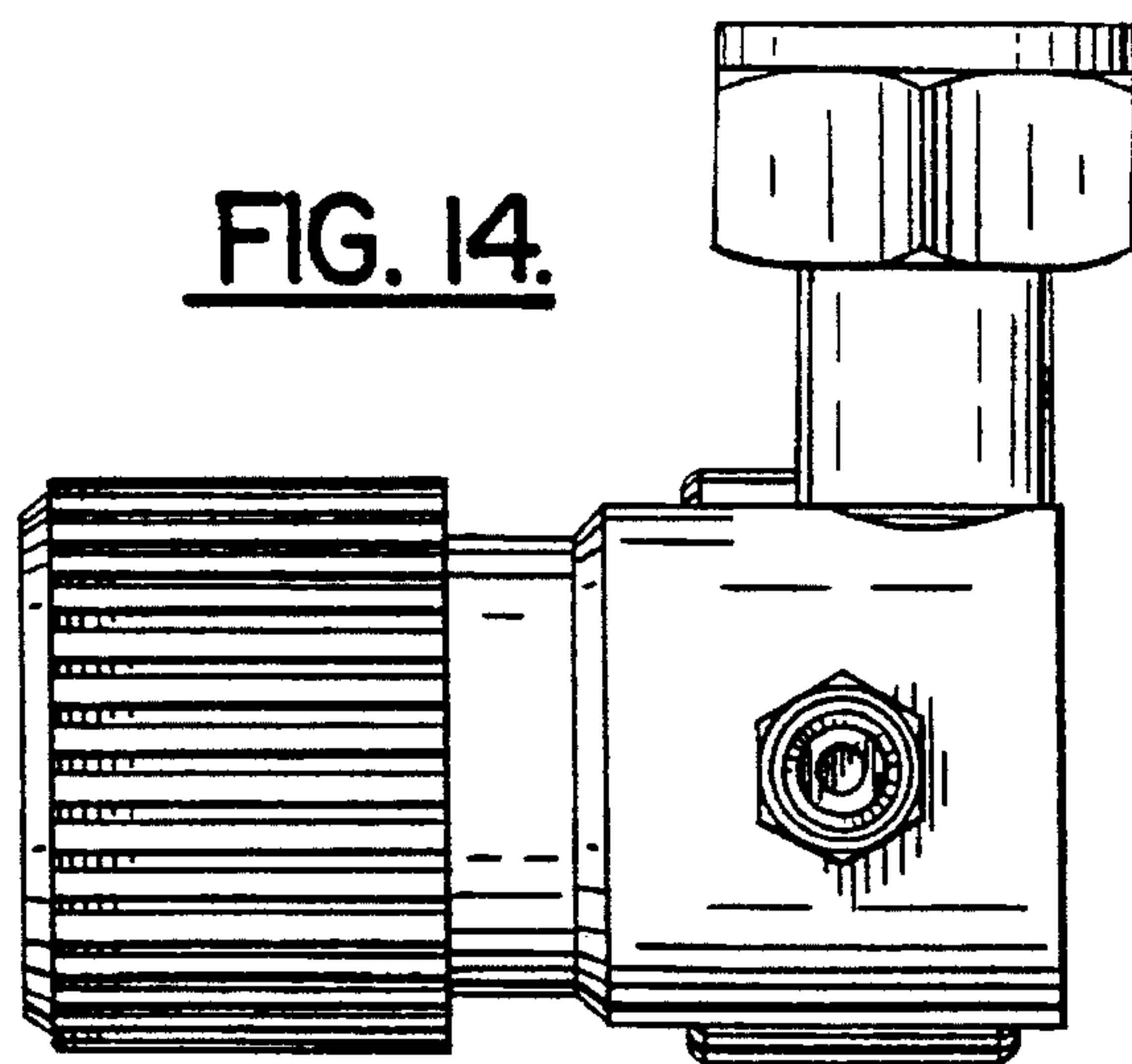
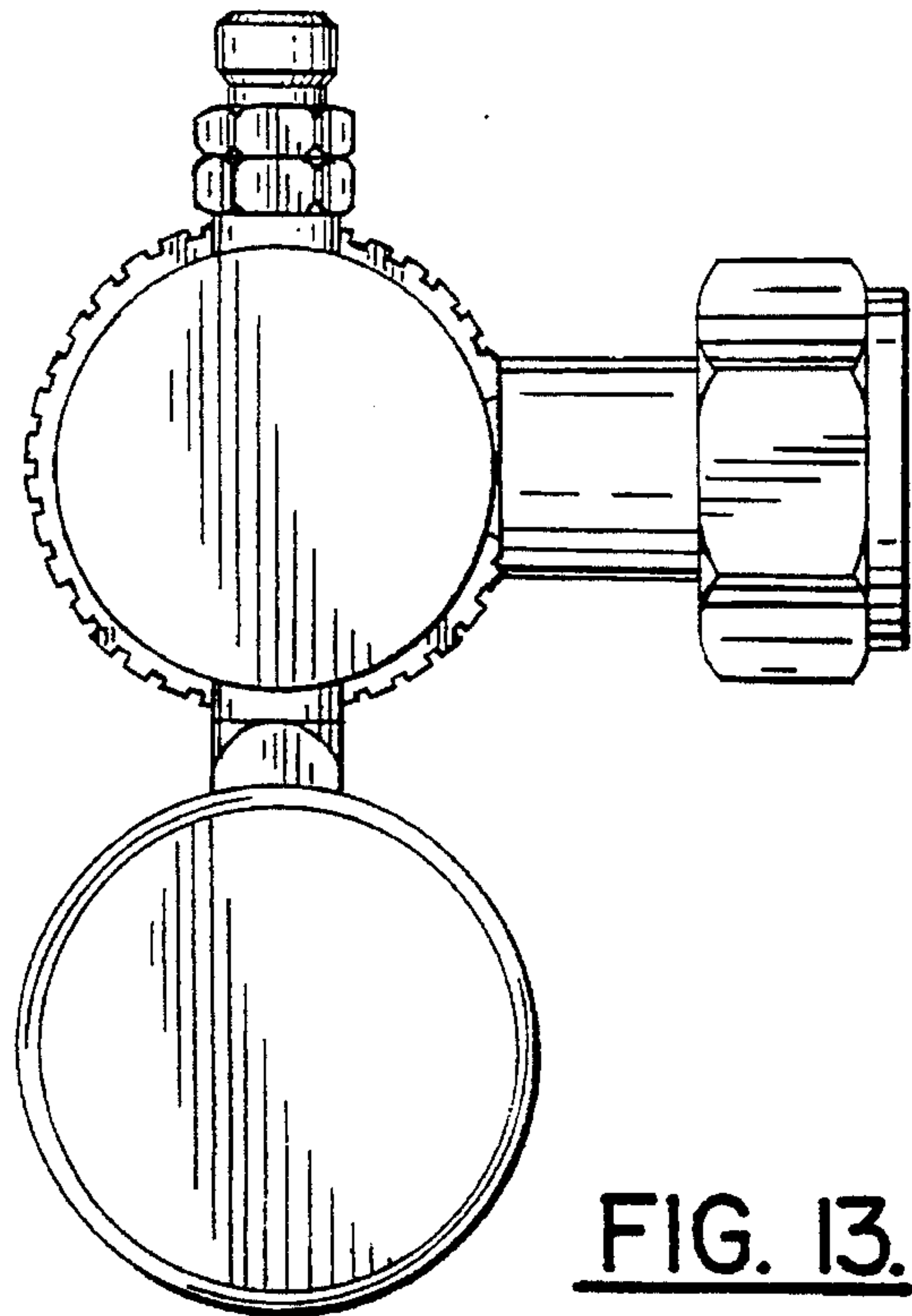
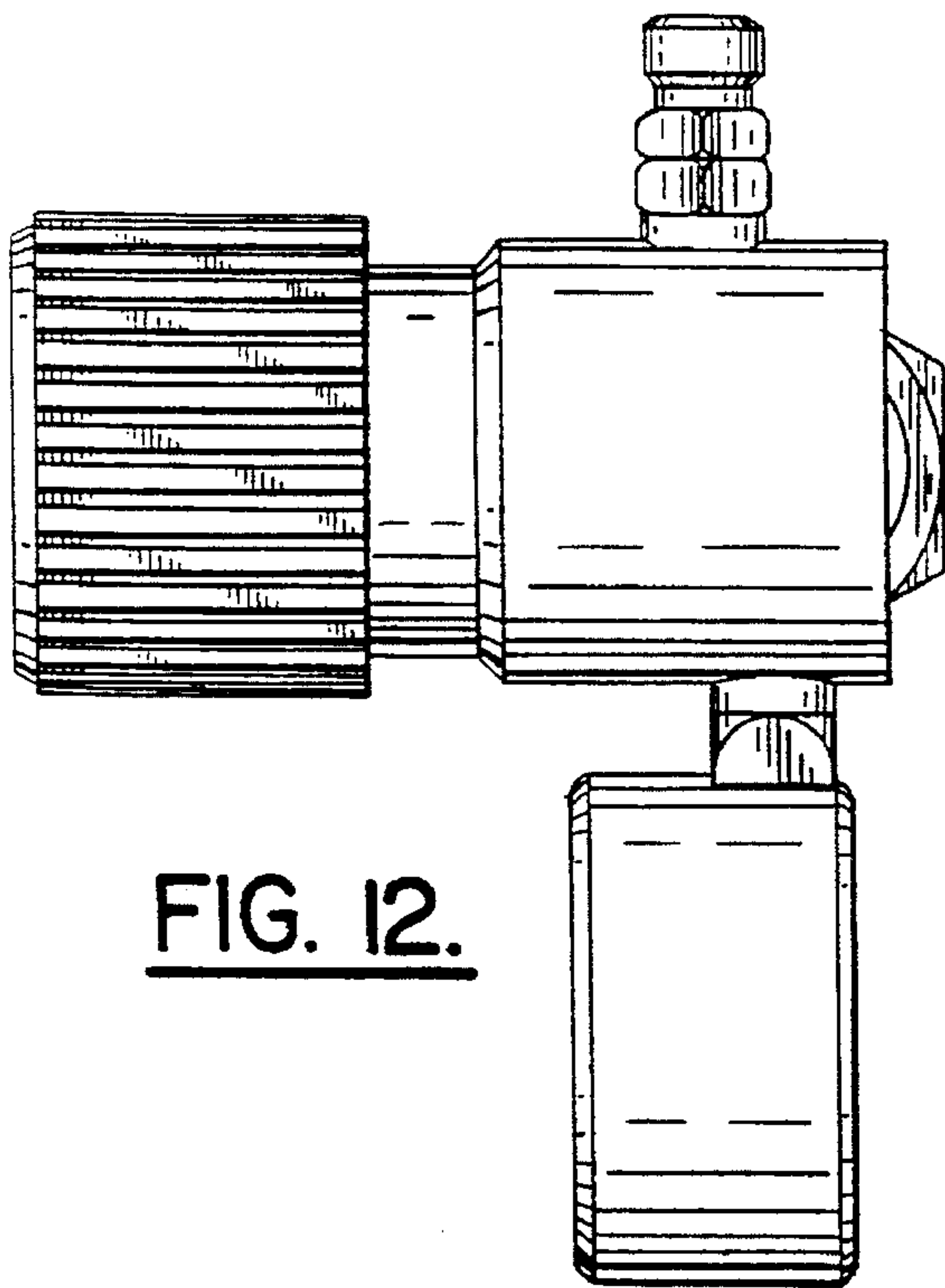

FIG. 10.



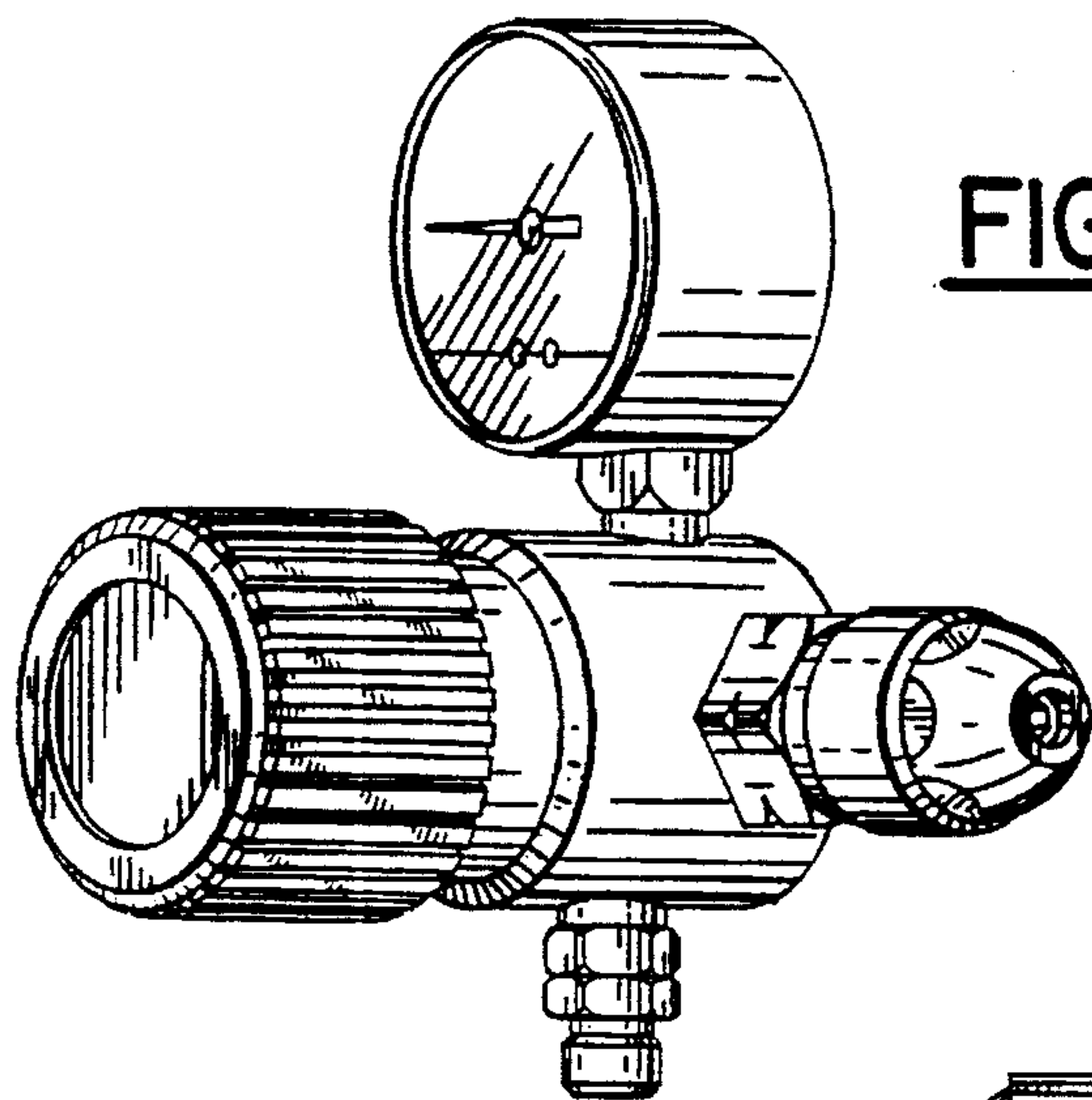

FIG. 15.

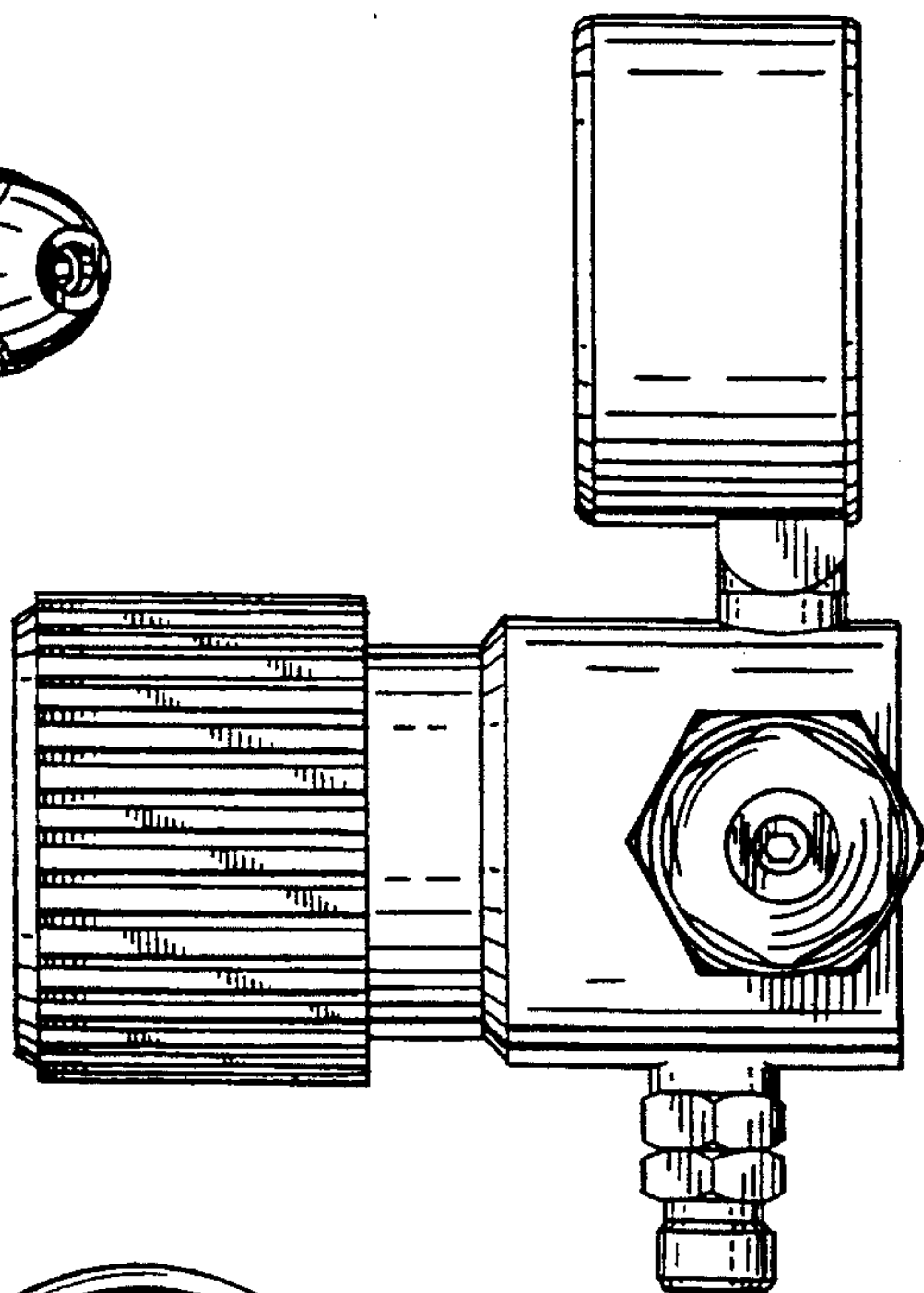

FIG. 16.

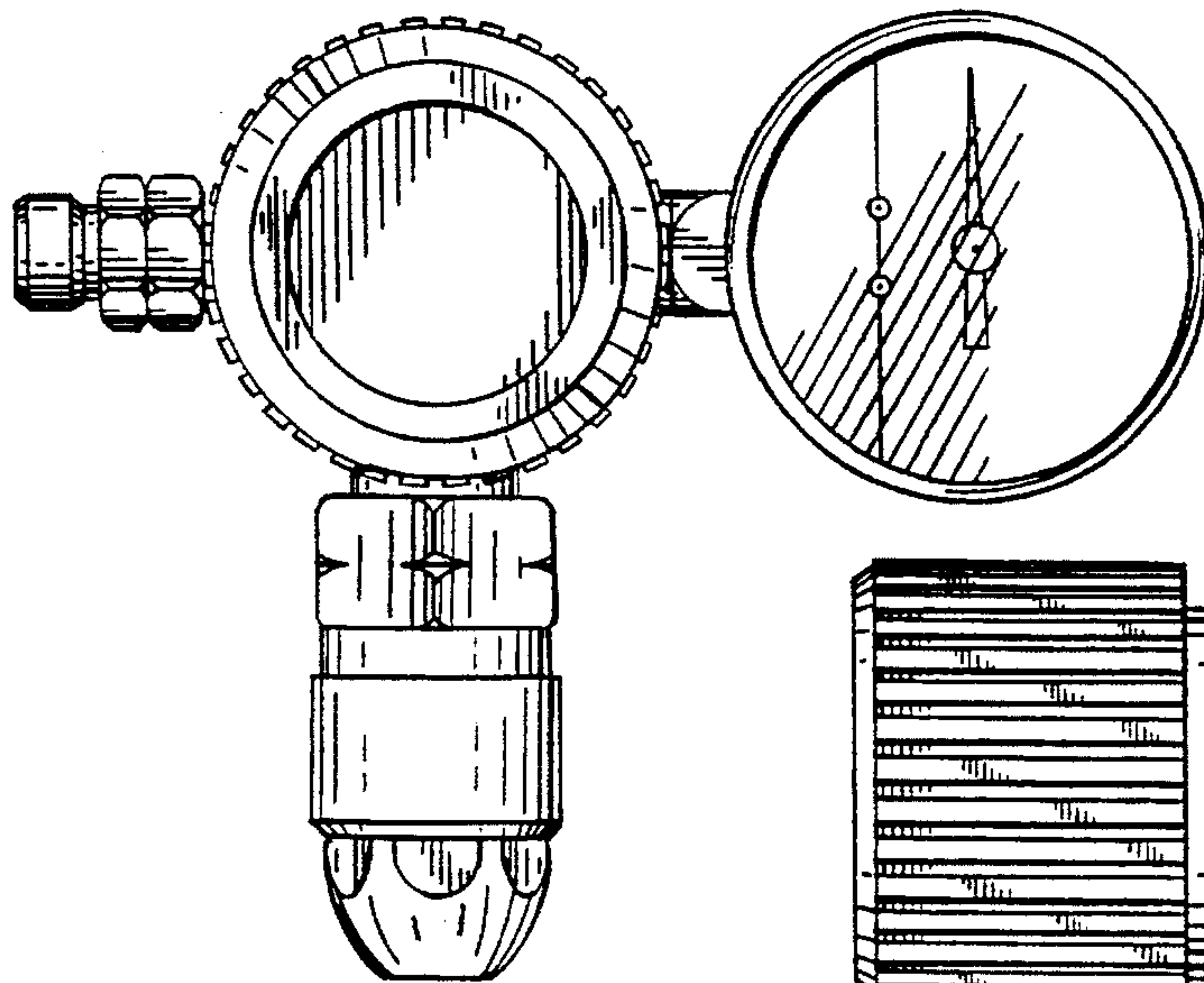

FIG. 18.

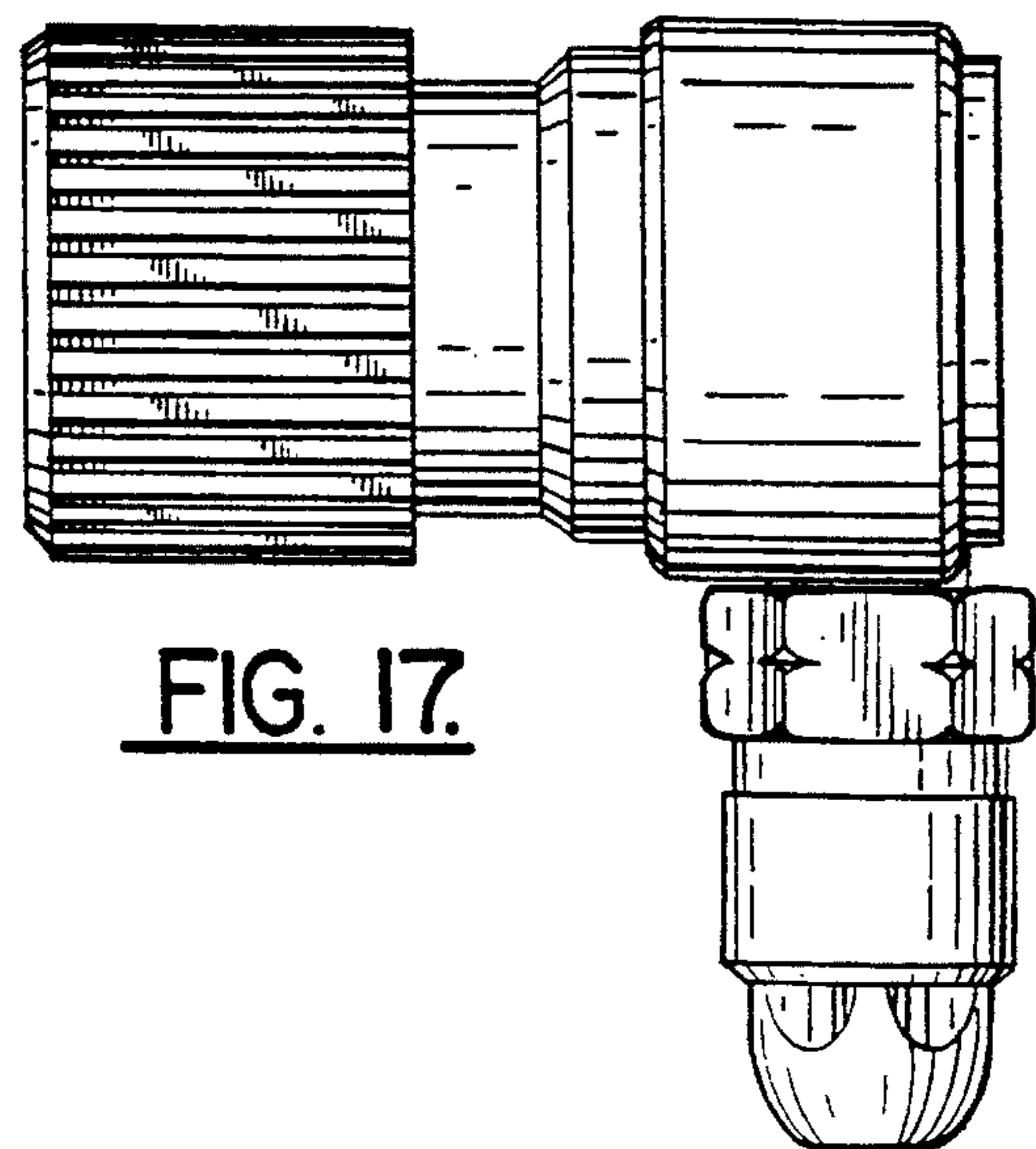

FIG. 17.

