



US00D378245S

**United States Patent** [19]  
**DeMier**

[11] **Patent Number:** **Des. 378,245**

[45] **Date of Patent:** **\*\*Mar. 4, 1997**

[54] **COMBINED SKI AND BOOT SLING**  
[76] Inventor: **Daniel W. DeMier**, 4103 S. Jasper St.,  
Aurora, Colo. 80013  
[\*\*] Term: **14 Years**  
[21] Appl. No.: **36,607**  
[22] Filed: **Feb. 16, 1995**

4,676,417 6/1987 Hirschkoff ..... 224/202  
4,815,642 3/1989 Ray ..... 224/258  
4,903,875 2/1990 Smart et al. .... 224/258  
5,040,324 8/1991 Rivera et al. .... 224/258 X  
5,083,692 1/1992 Treese ..... 224/205  
5,160,074 11/1992 Coates ..... 224/257  
5,318,209 6/1994 Rader et al. .... 224/250  
5,335,835 8/1994 Hogan ..... 224/257

**Related U.S. Application Data**

[63] Continuation-in-part of Ser. No. 31,133, Nov. 18, 1994.  
[52] **U.S. Cl.** ..... **D3/261**  
[58] **Field of Search** ..... **D3/261, 317; 224/150,**  
**224/202, 206, 258, 917**

*Primary Examiner*—Doris V. Coles  
*Assistant Examiner*—Catherine R. Oliver  
*Attorney, Agent, or Firm*—Sheridan Ross P.C.

[57] **CLAIM**

The ornamental design for a combined ski and boot sling, as shown and described.

**DESCRIPTION**

[56] **References Cited**

**U.S. PATENT DOCUMENTS**

D. 325,300 4/1992 Miklus, II ..... D3/226 X  
D. 335,576 5/1993 Phillpott ..... D3/317  
2,970,729 2/1961 Allen ..... D3/316 X  
3,841,542 10/1974 Hogensen, Jr. .... 224/151  
3,920,166 11/1975 Hogensen, Jr. .... 224/151  
4,261,493 4/1981 Newman ..... 224/257  
4,308,982 1/1982 Hall ..... 224/202  
4,470,528 9/1984 Dyess ..... 224/257  
4,518,107 5/1985 Amos ..... 224/215  
4,629,103 12/1986 Miller ..... 224/257 X  
4,658,999 4/1987 Hilty ..... 224/202

FIG. 1 is a perspective of a combined ski and boot sling showing my new design;  
FIG. 2 is a top plan view thereof;  
FIG. 3 is a side elevation view thereof;  
FIG. 4 is a side elevation view thereof;  
FIG. 5 is a bottom plan view thereof;  
FIG. 6 is a side view thereof; and,  
FIG. 7 is an alternative embodiment identical to the design illustrated in FIG. 1, with the exception of the boot loop and associated strap, which are removed.

**1 Claim, 5 Drawing Sheets**

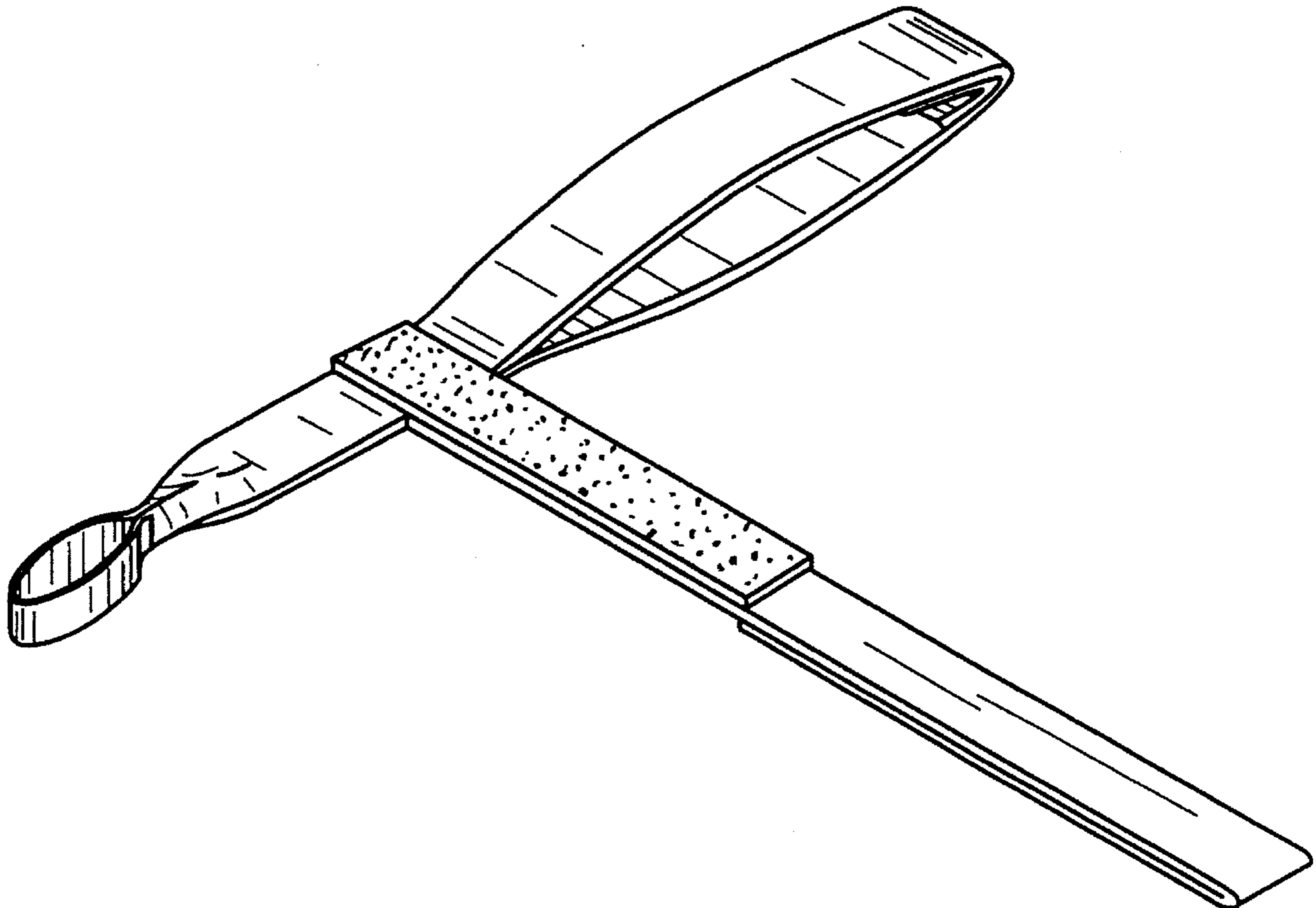

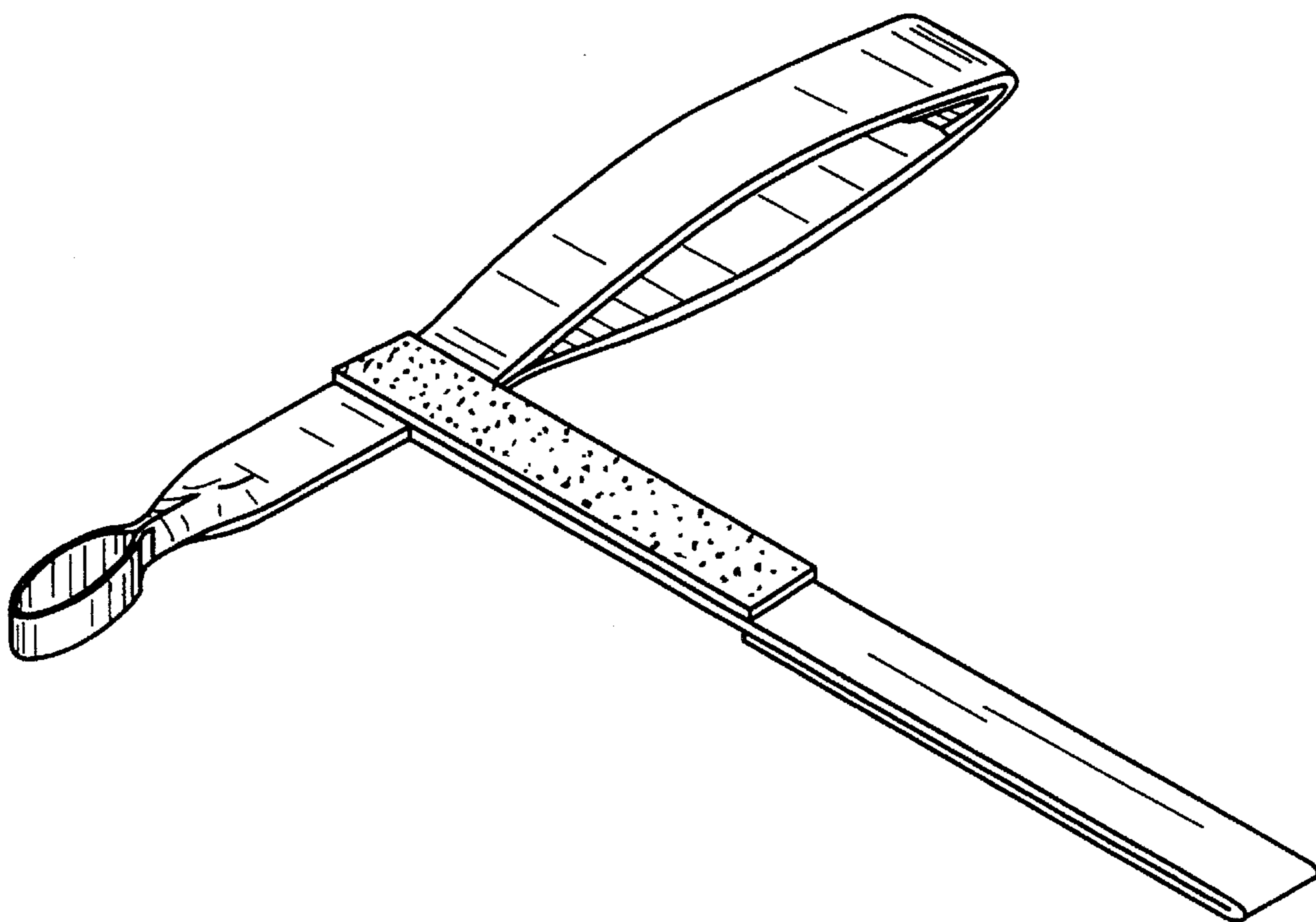

Fig. 1

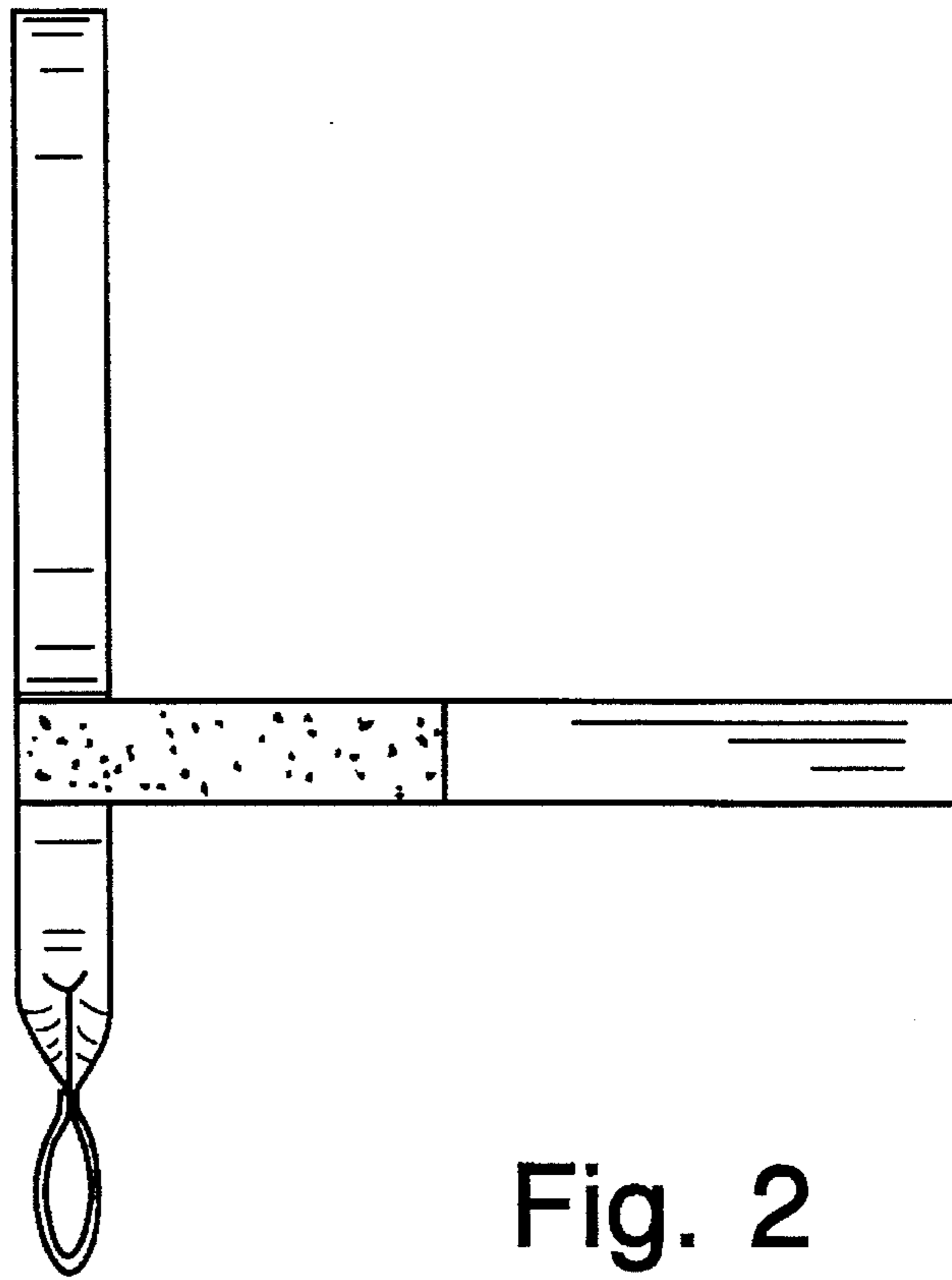

Fig. 2



Fig. 3

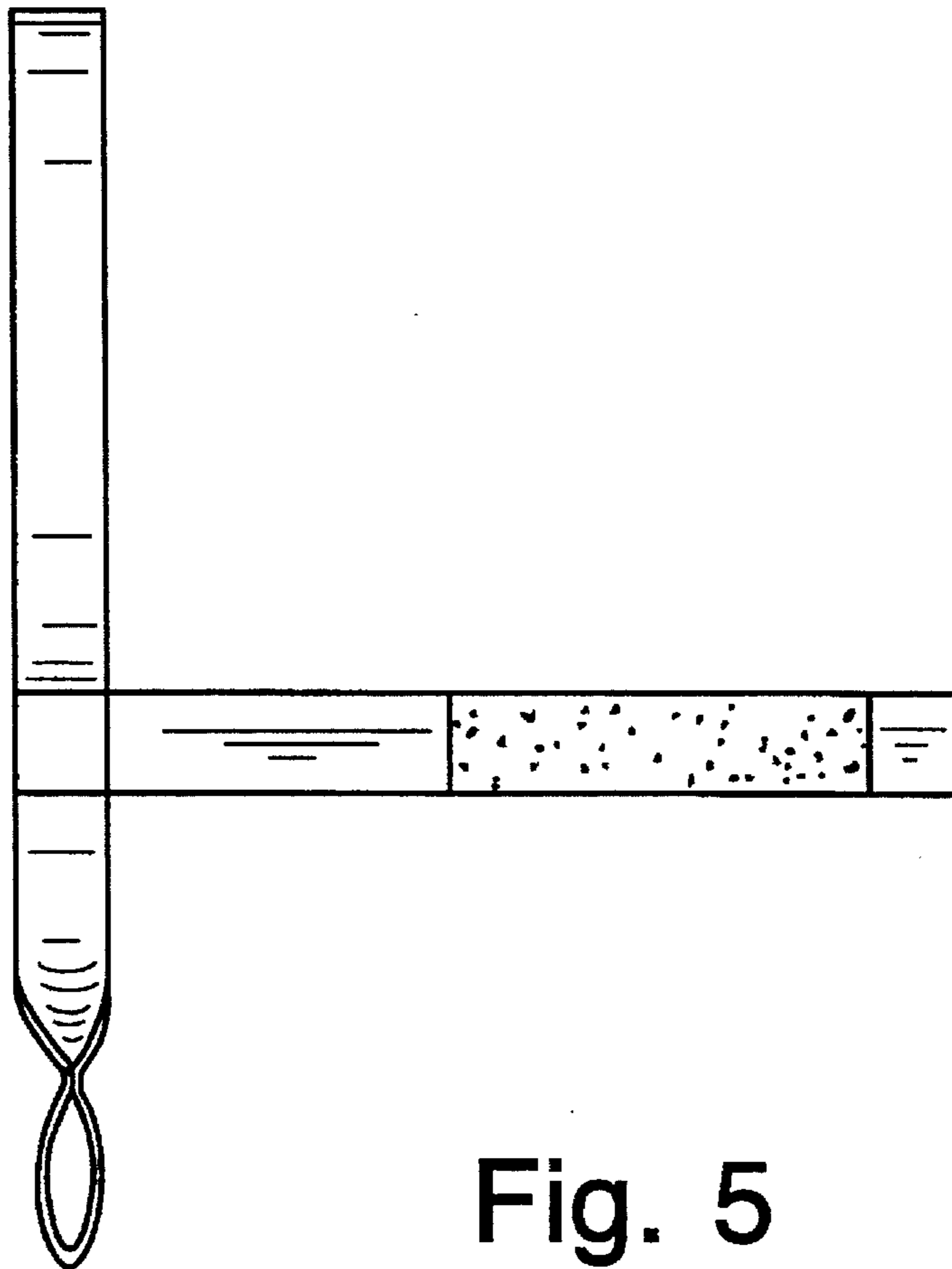

Fig. 5



Fig. 4

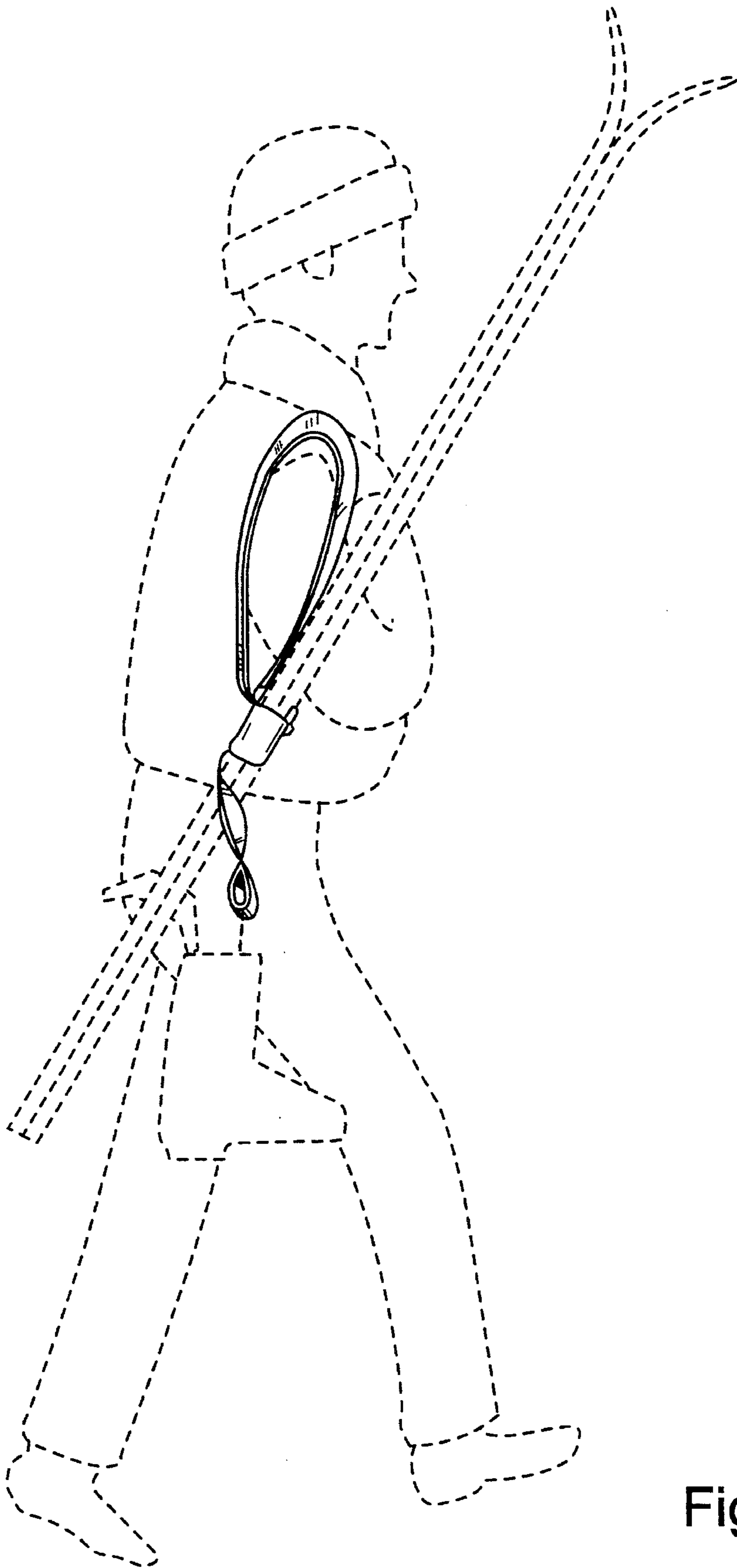

Fig. 6

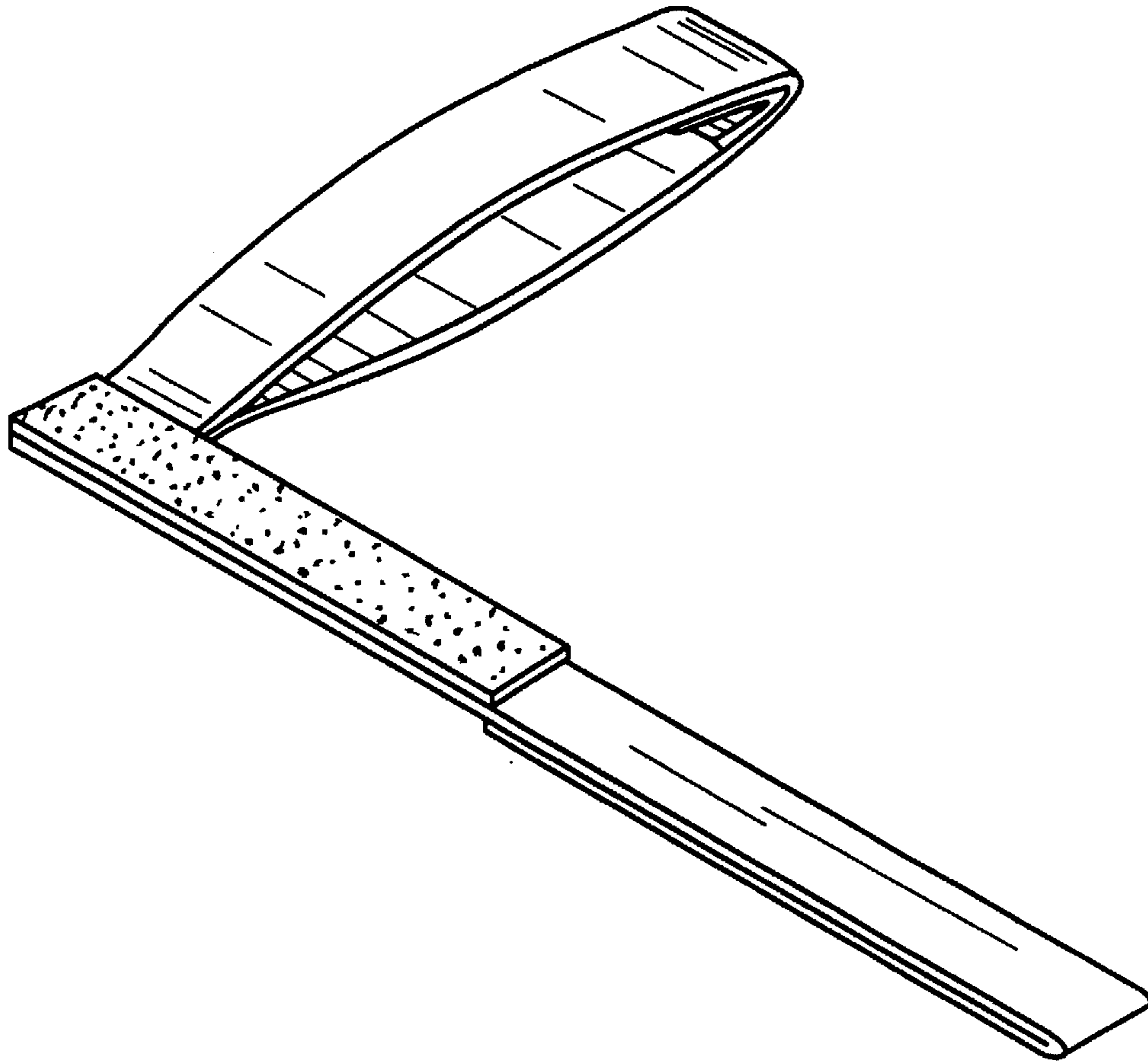

Fig. 7