



US00D378082S

United States Patent [19]

[11] Patent Number: Des. 378,082

Wilson

[45] Date of Patent: **Feb. 18, 1997

[54] **FREESTANDING INTERACTIVE
COMPUTERIZED INFORMATION SYSTEM**

[75] Inventor: Donald Wilson, Toronto, Canada

[73] Assignee: King Products Inc., Mississauga,
Canada

[**] Term: 14 Years

[21] Appl. No.: 46,254

[22] Filed: Nov. 9, 1995

Related U.S. Application Data

[63] Continuation-in-part of Ser. No. 37,821, Apr. 21, 1995.

[30] Foreign Application Priority Data

Dec. 22, 1994 [CA] Canada 1994-2529

[52] U.S. Cl. D14/100; D10/93; D20/10

[58] Field of Search D14/100, 101,
D14/103, 106, 113, 124-129; D13/162,
184, 199; D10/93; D20/10; 345/104, 133,
156, 168, 173, 87, 901-905; 248/917-924

[56] References Cited

U.S. PATENT DOCUMENTS

- D. 281,403 11/1985 Zeigner et al. D10/93
- D. 294,354 2/1988 West et al. D14/128 X
- D. 305,993 2/1990 Carnevale et al. D10/93
- D. 325,541 4/1992 Storsberg D10/93
- D. 334,775 4/1993 Foster D20/10
- D. 335,676 2/1995 Wilson D20/10

Primary Examiner—Freda Nunn

Attorney, Agent, or Firm—Sim & McBurney

[57] CLAIM

The ornamental design for a freestanding interactive computerized information system, as shown and described.

DESCRIPTION

FIG. 1 is a perspective view of the freestanding interactive computerized information system according to my design;

FIG. 2 is a front elevation view of the system shown in FIG. 1;

FIG. 3 is a rear elevation view of the system shown in FIG. 1;

FIG. 4 is a right side elevation view of the system shown in FIG. 1, the left side elevation view being a mirror image of the view shown in FIG. 4;

FIG. 5 is a top plan view of the system shown in FIG. 1; FIG. 6 is a bottom plan view of the system shown in FIG. 1;

FIG. 7 is a perspective view of a second embodiment of the freestanding interactive computerized information system; FIG. 8 is a front elevation view of the system shown in FIG. 7;

FIG. 9 is a rear elevation view of the system shown in FIG. 7;

FIG. 10 is a right side elevation view of the system shown in FIG. 7, the left side elevation view being a mirror image of the view shown in FIG. 10;

FIG. 11 is a top plan view of the system shown in FIG. 7; FIG. 12 is a bottom plan view of the system shown in FIG. 7;

FIG. 13 a perspective view of a third embodiment of the freestanding interactive computerized information system; FIG. 14 is a front elevation view of the system shown in FIG. 13;

FIG. 15 is a rear elevation view of the system shown in FIG. 13;

FIG. 16 is a right side elevation view of the system shown in FIG. 13, the left side elevation view being a mirror image of the view shown in FIG. 16;

FIG. 17 is a top plan view of the system shown in FIG. 13; FIG. 18 is a bottom plan view of the system shown in FIG. 13;

FIG. 19 is a perspective view of a fourth embodiment of the freestanding interactive computerized information system; FIG. 20 is a front elevation view of the system shown in FIG. 19;

FIG. 21 is a rear elevation view of the system shown in FIG. 19;

FIG. 22 is a right side elevation view of the system shown in FIG. 19, the left side elevation view being a mirror image of the view shown in FIG. 22;

FIG. 23 is a top plan view of the system shown in FIG. 19; FIG. 24 is a bottom plan view of the system shown in FIG. 19;

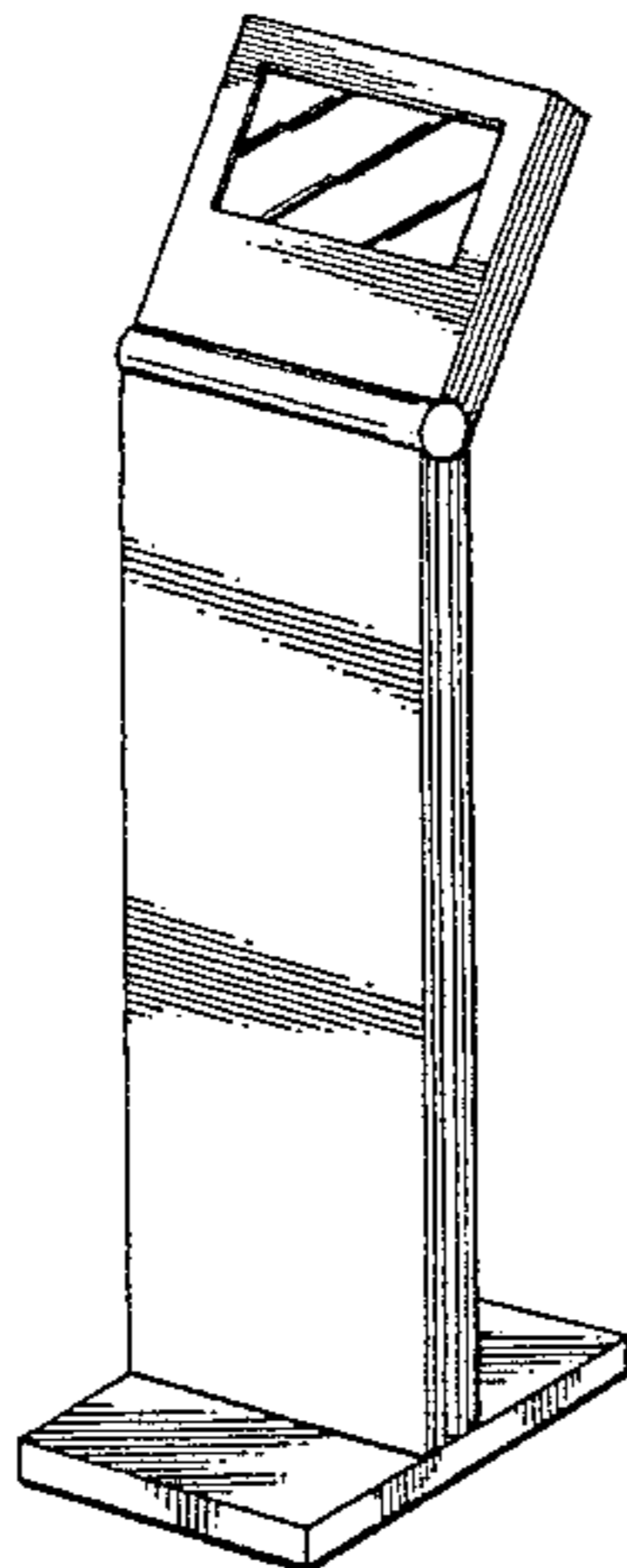

FIG. 25 is a perspective view of a fifth embodiment of the freestanding interactive computerized information system; FIG. 26 is a front elevation view of the system shown in FIG. 25; FIG. 27 is a rear elevation view of the system shown in FIG. 25; FIG. 28 is a right side elevation view of the system shown in FIG. 25, the left side elevation view being a mirror image of the view shown in FIG. 28;

FIG. 29 is a top plan view of the system shown in FIG. 25; and,

FIG. 30 is a bottom plan view of the system shown in FIG. 25;

1 Claim, 5 Drawing Sheets

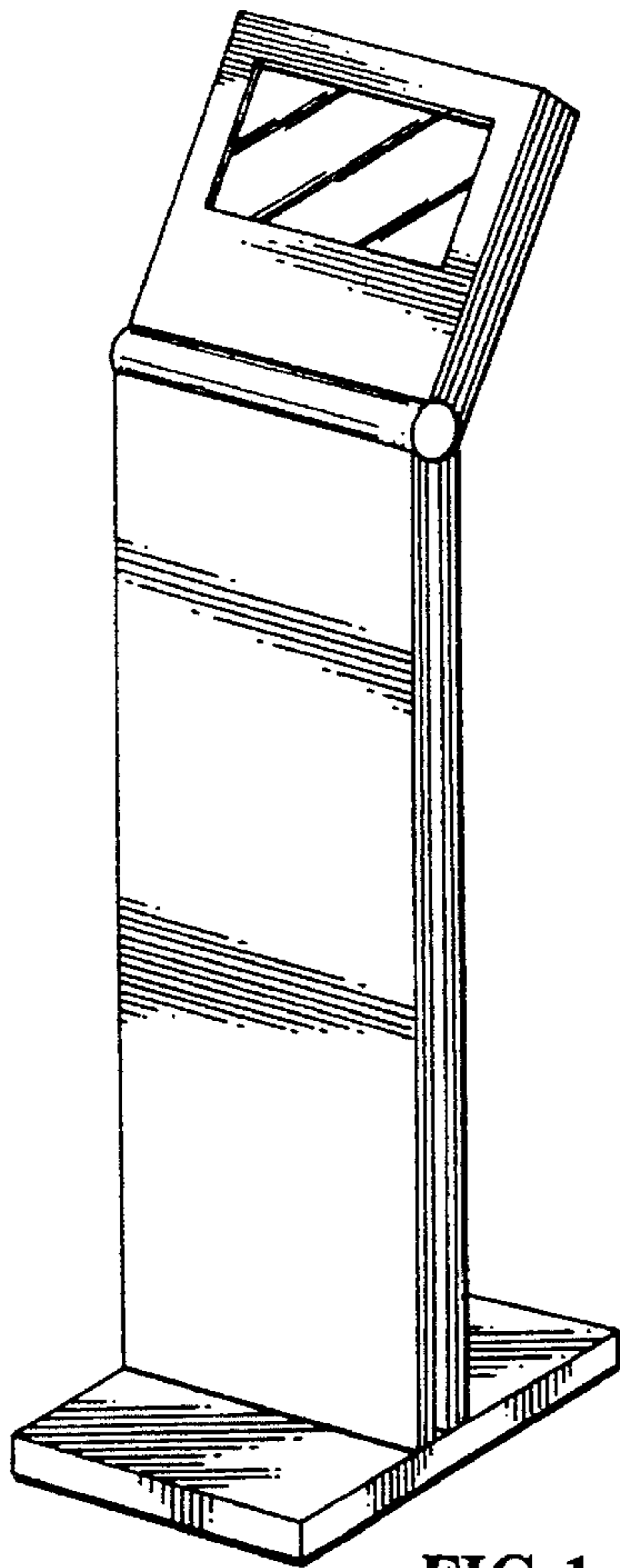

FIG 1

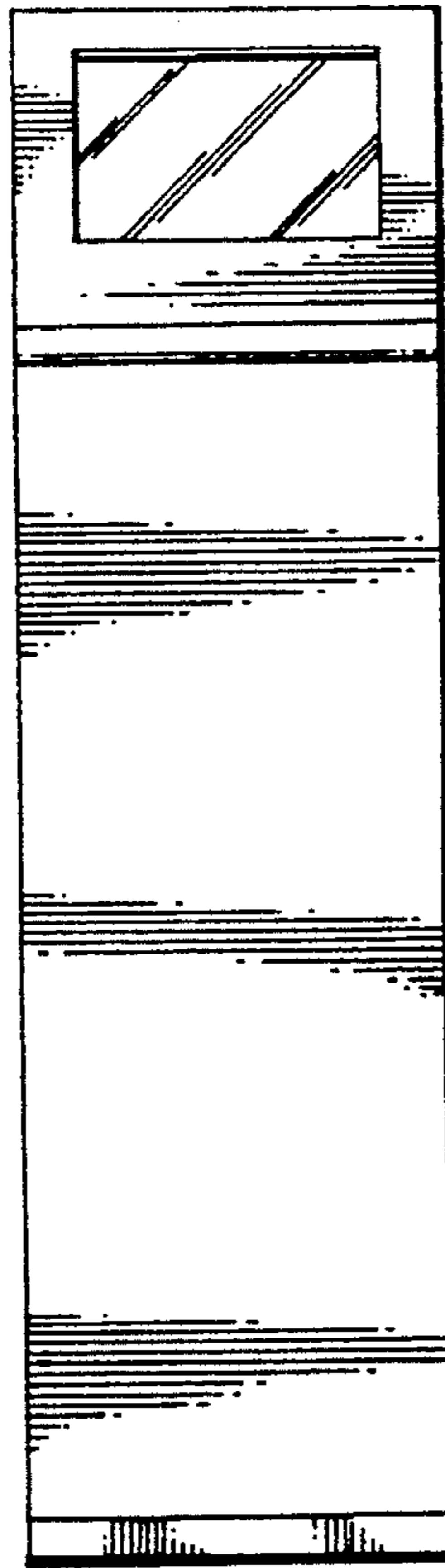

FIG 2

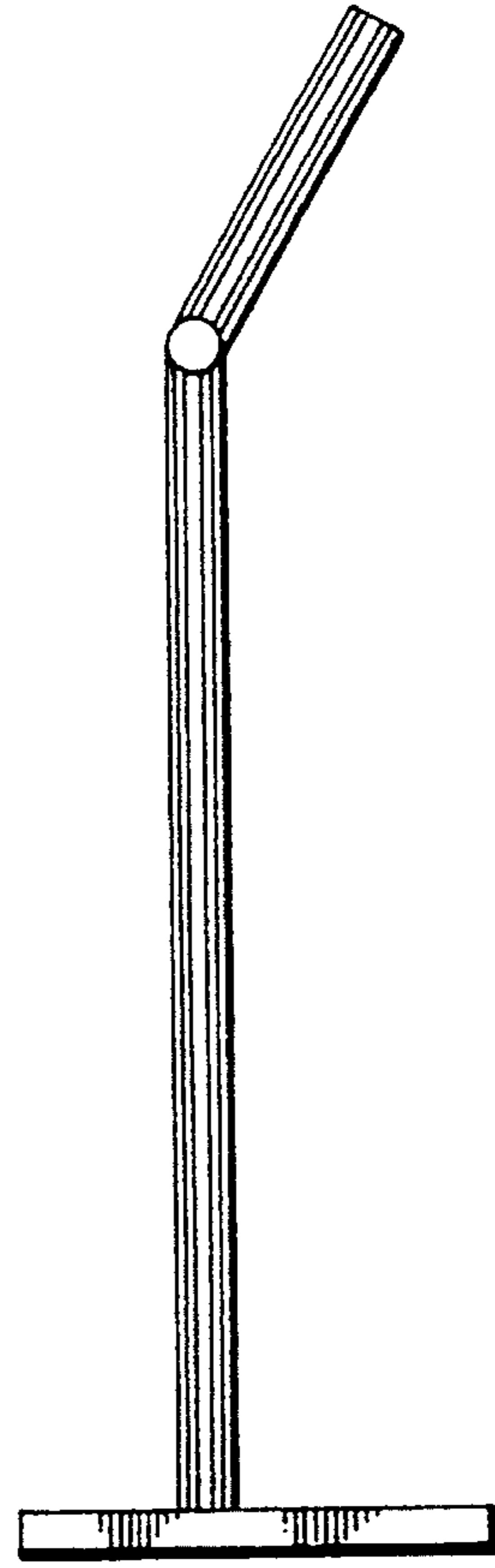

FIG 4

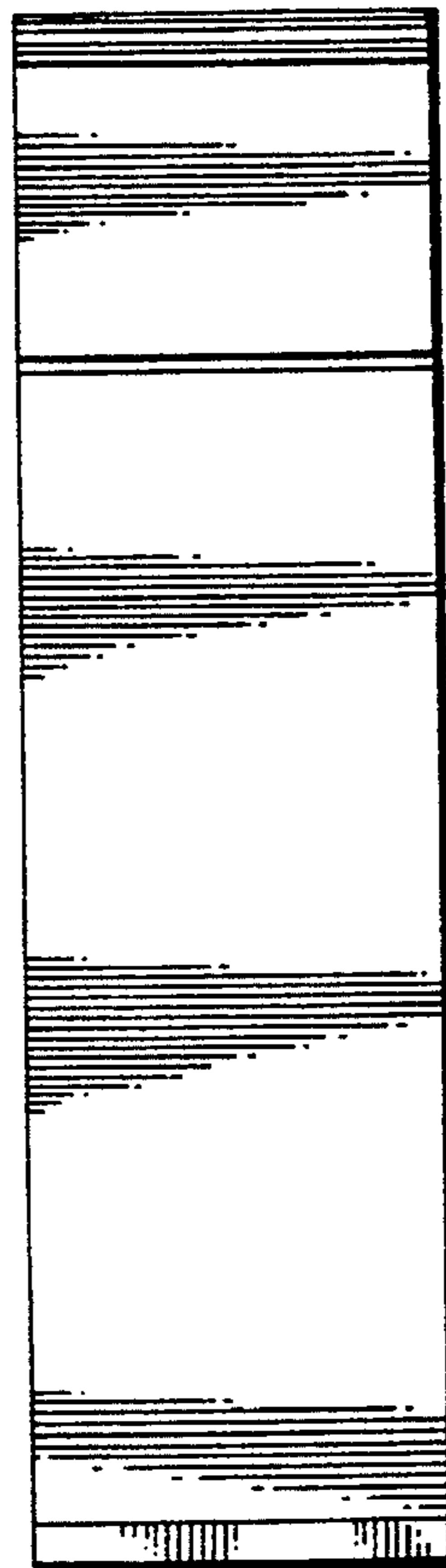

FIG 3

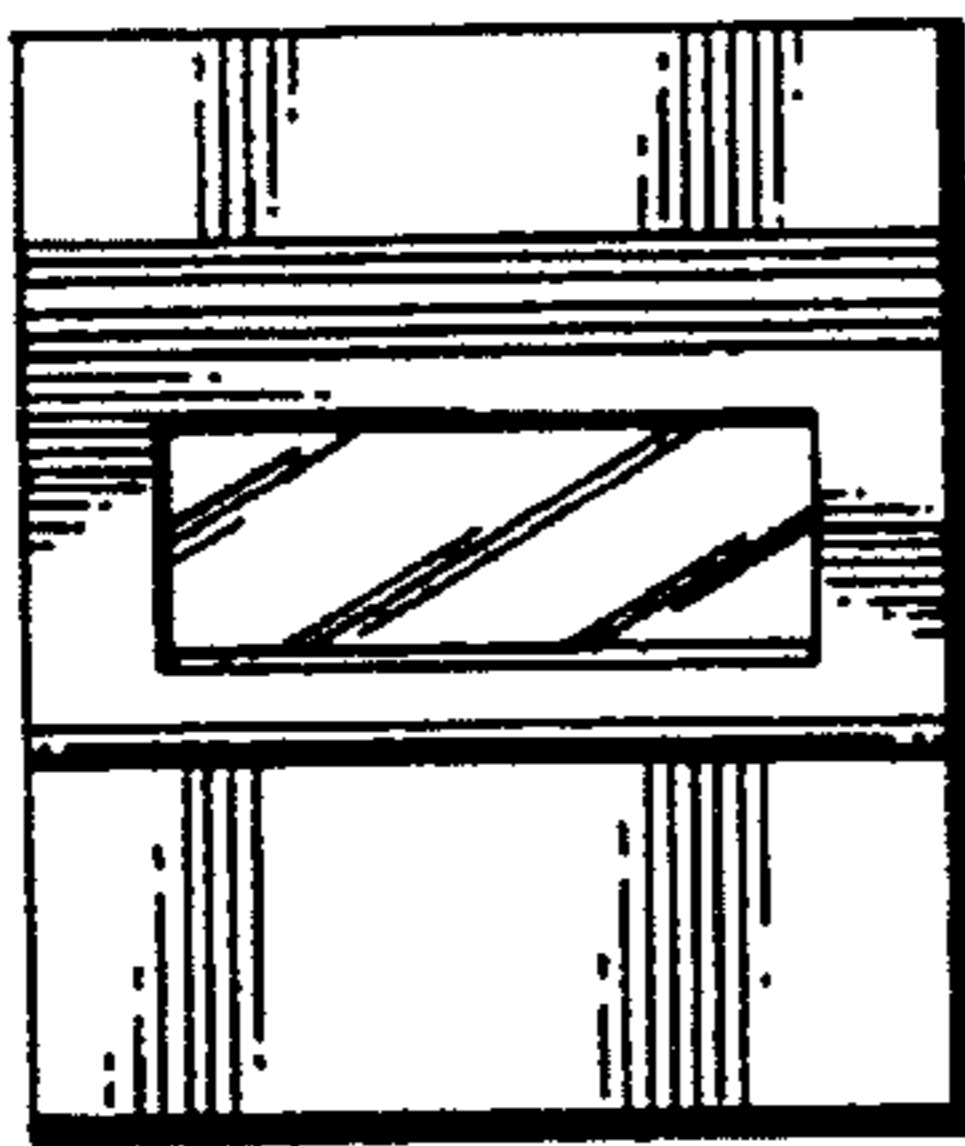

FIG 5

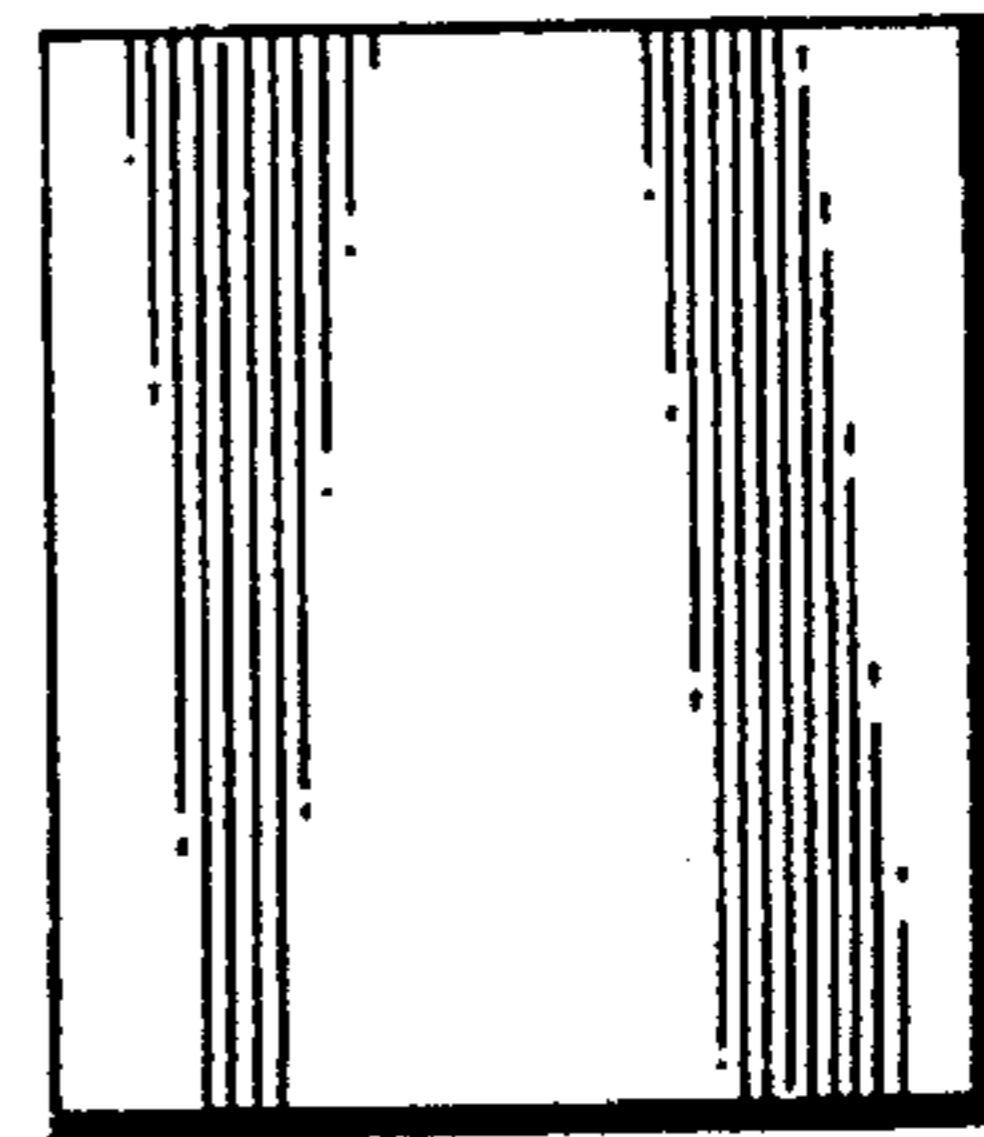

FIG 6

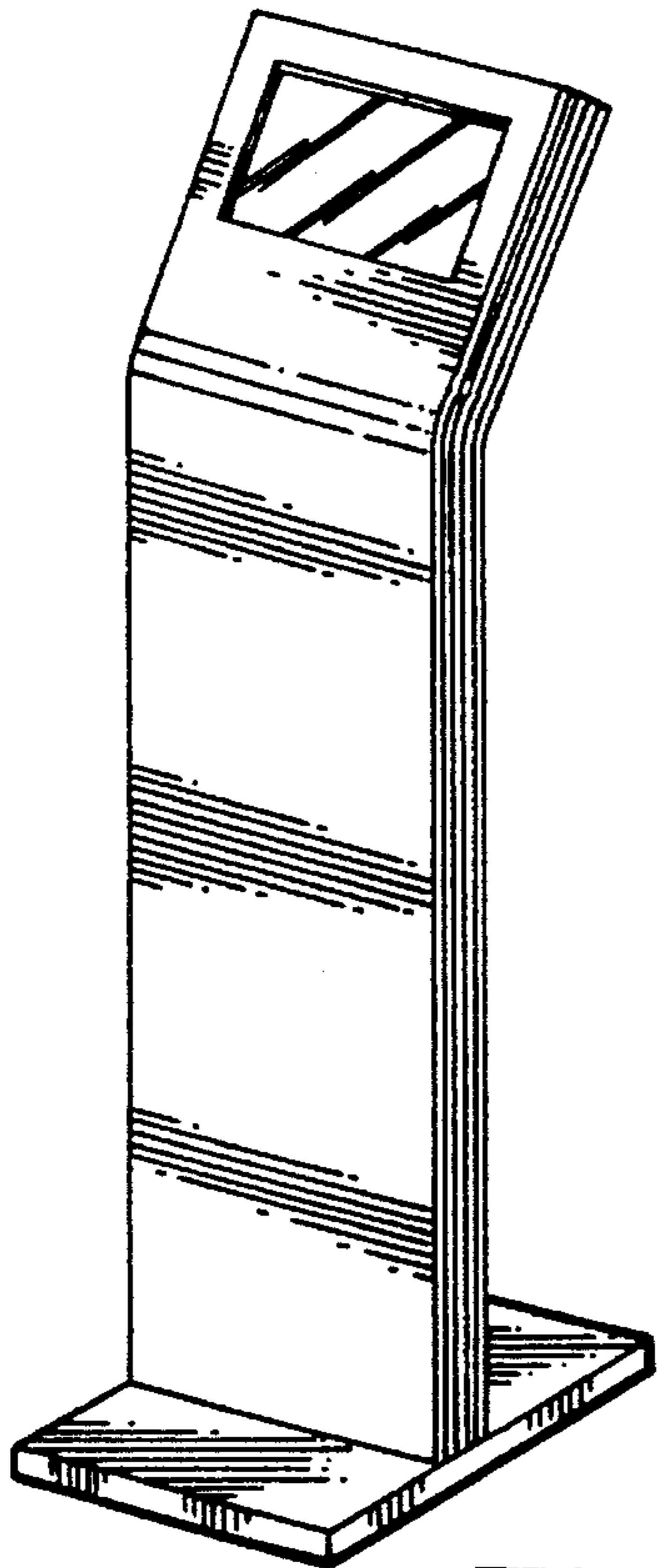

FIG 7

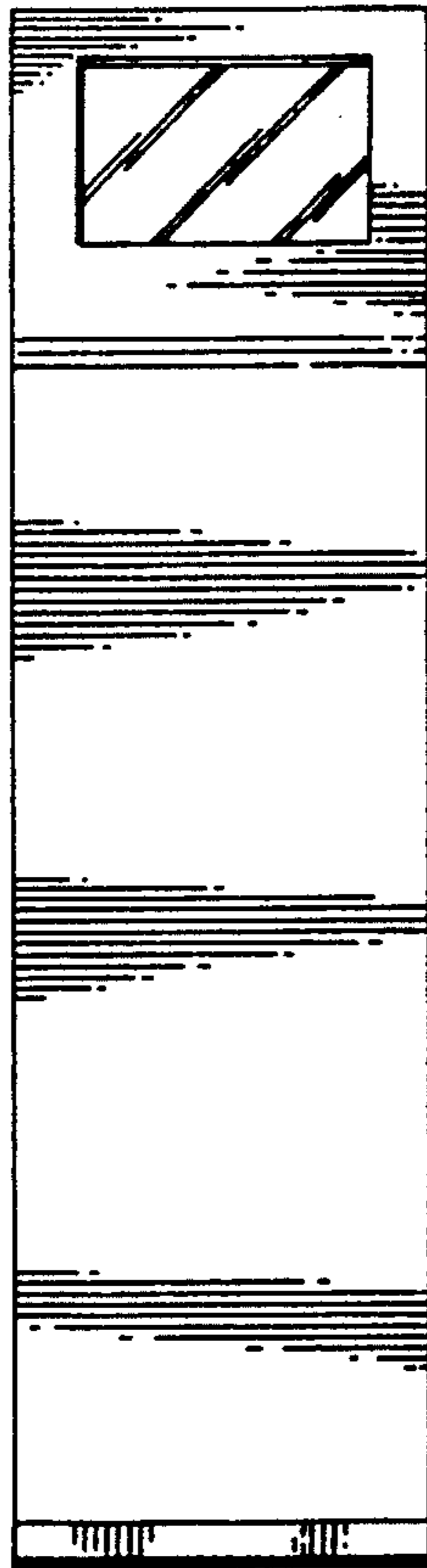

FIG 8

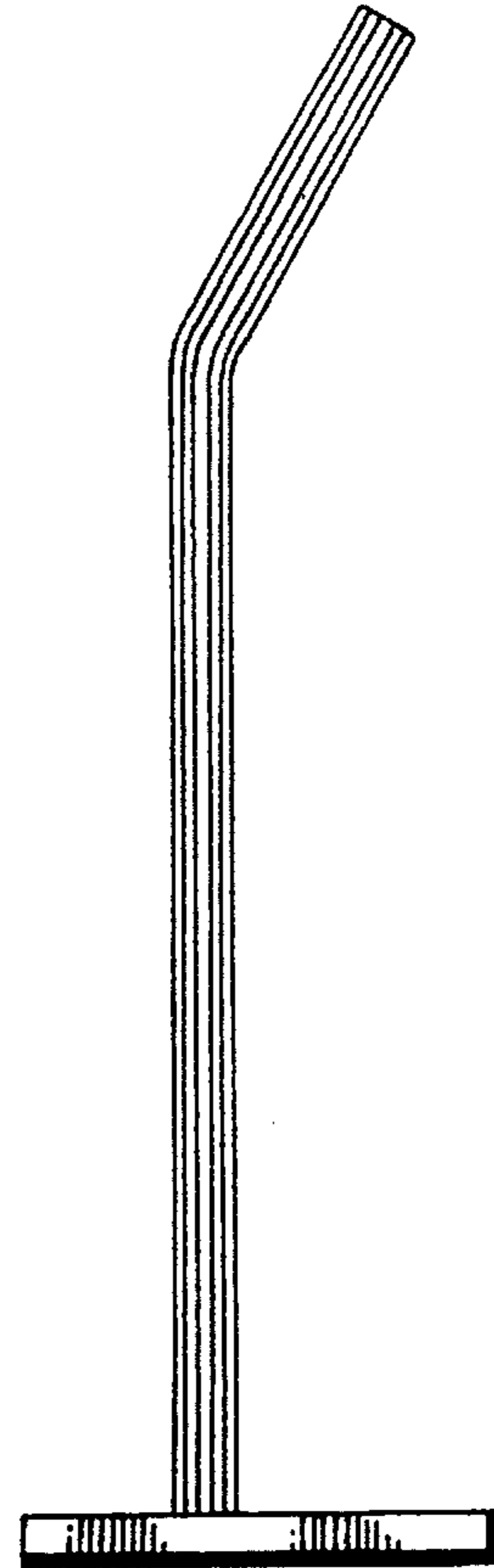

FIG 10

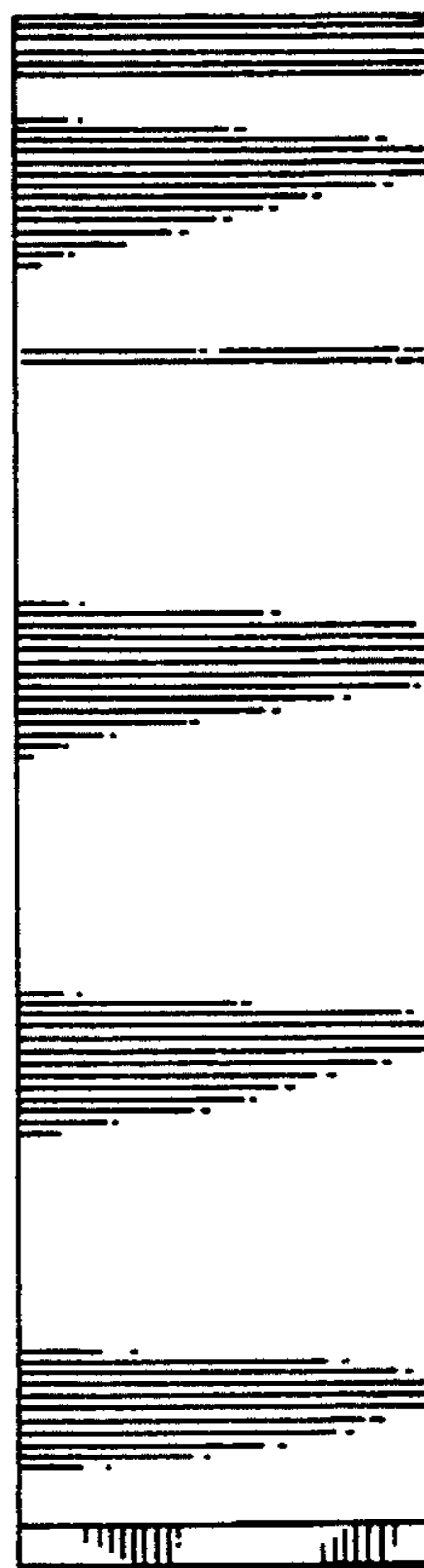

FIG 9

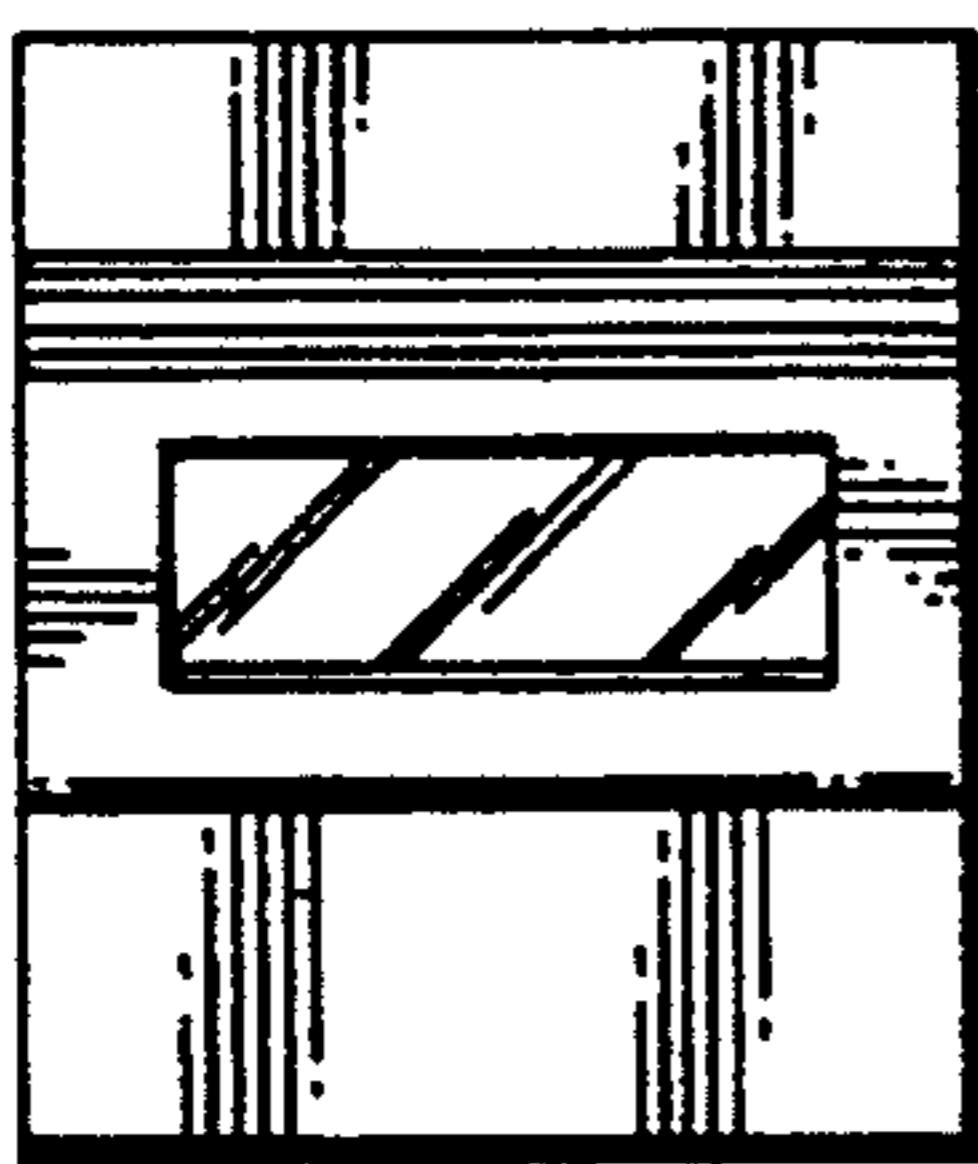

FIG 11

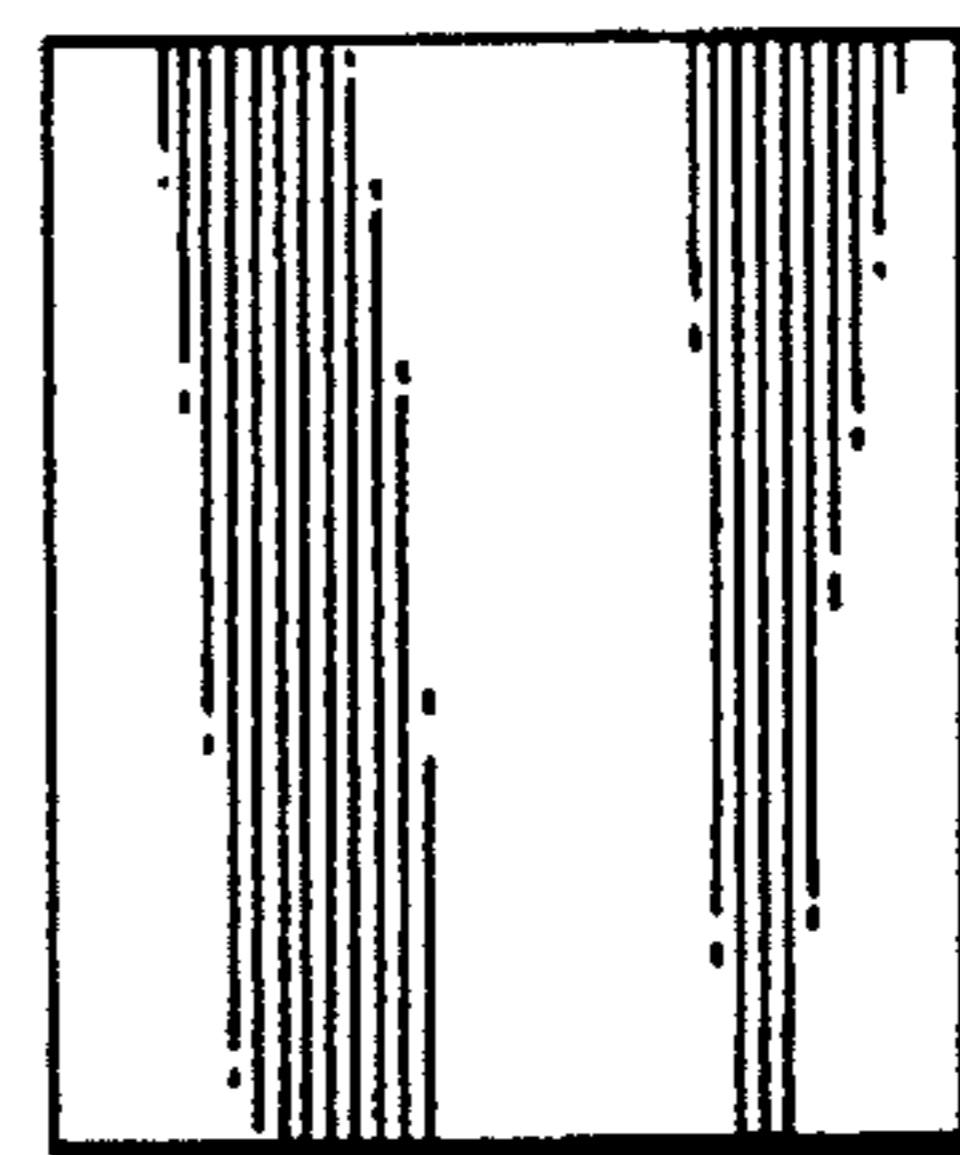

FIG 12

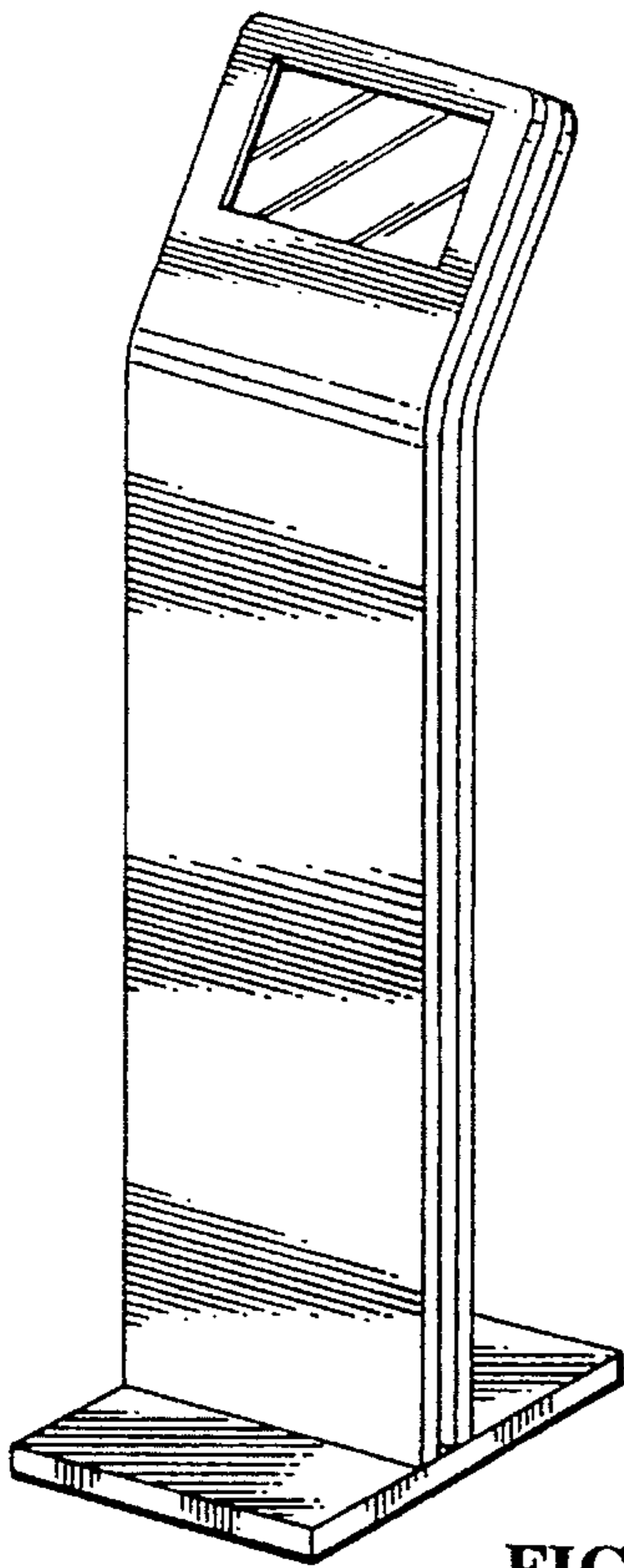

FIG 13

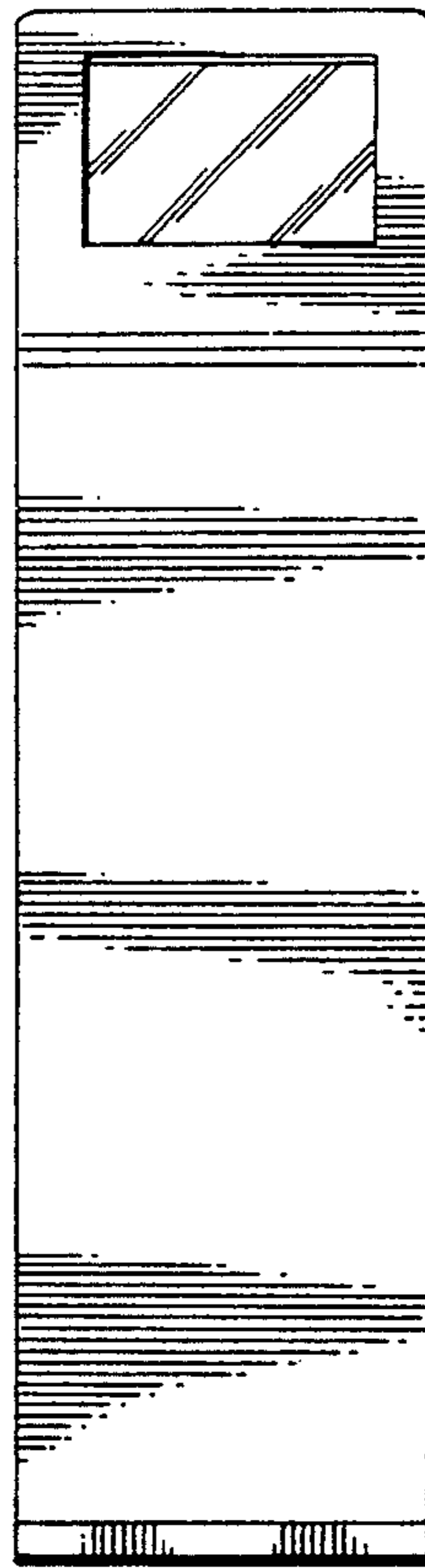

FIG 14

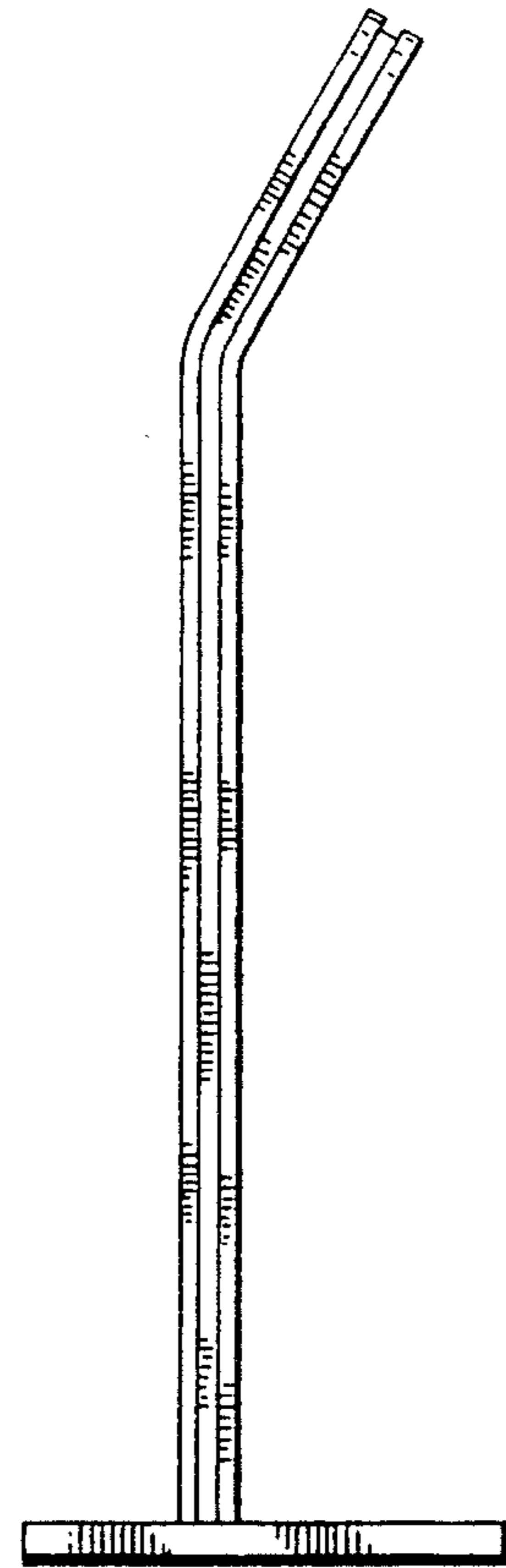

FIG 16

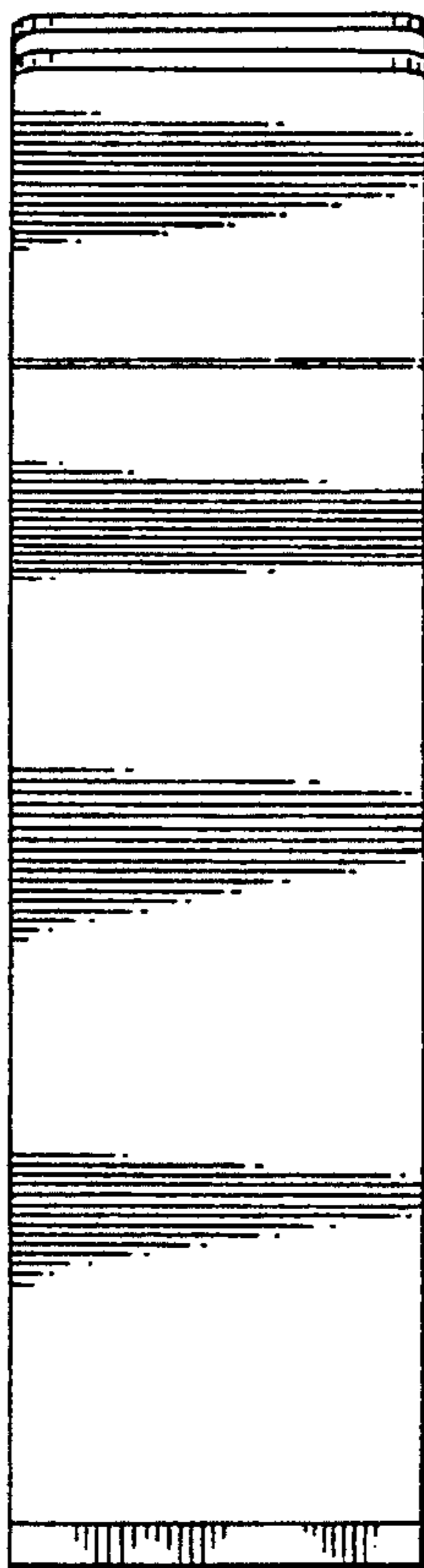

FIG 15

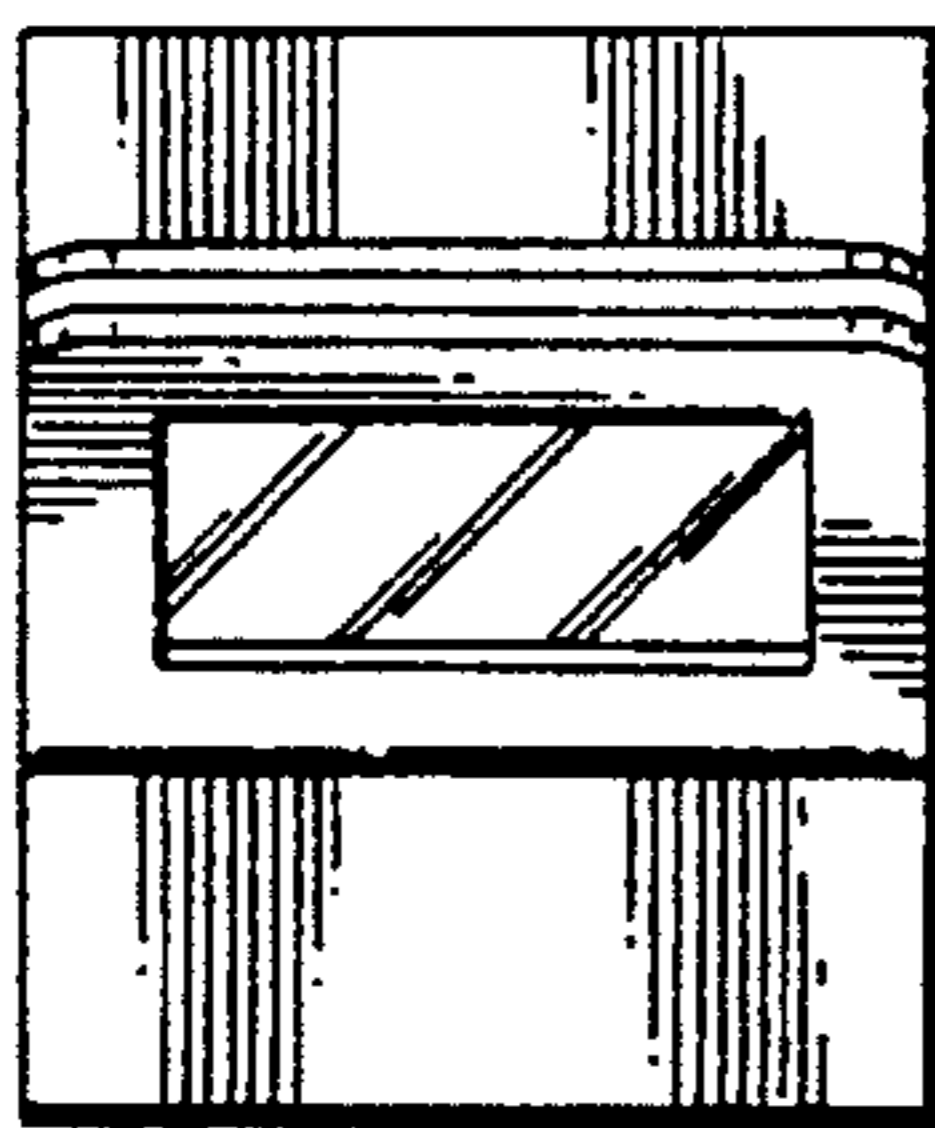

FIG 17

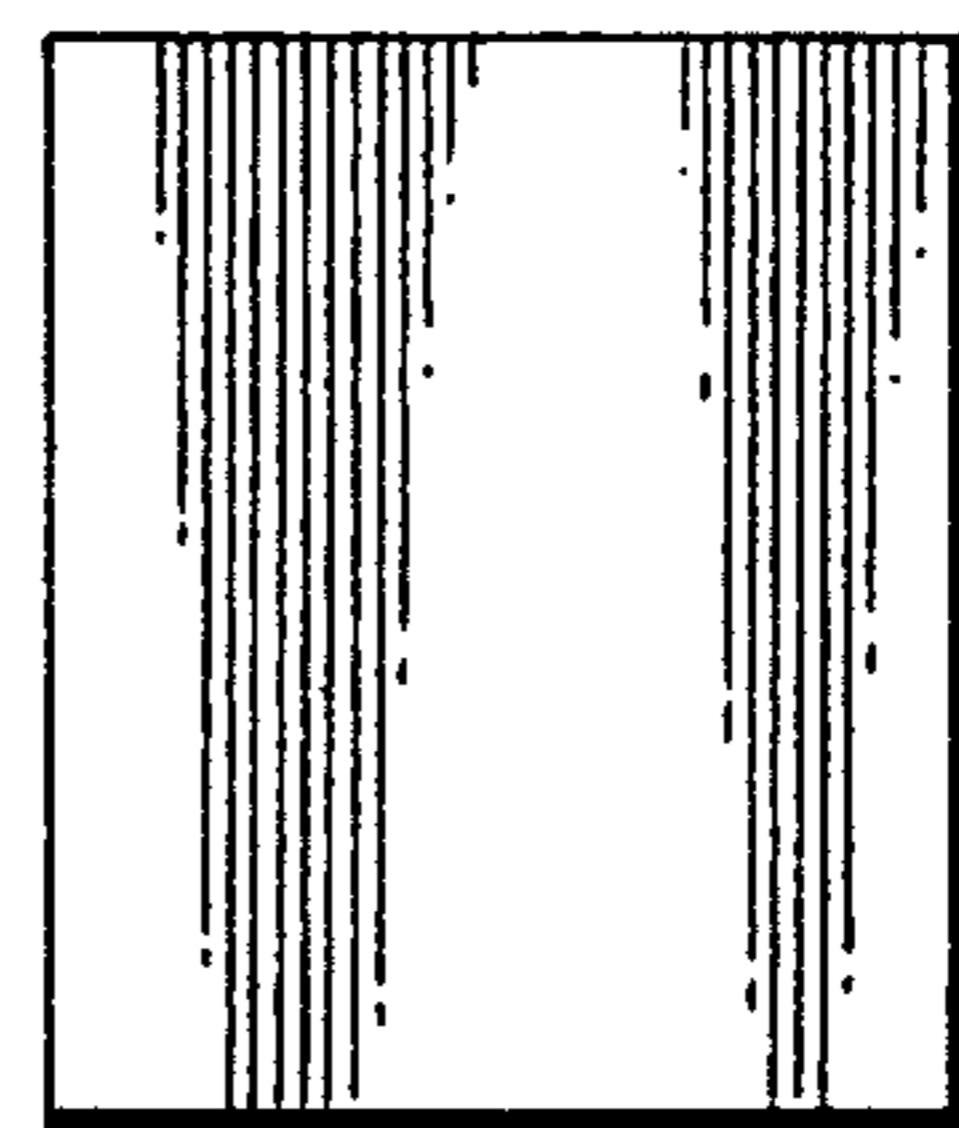

FIG 18

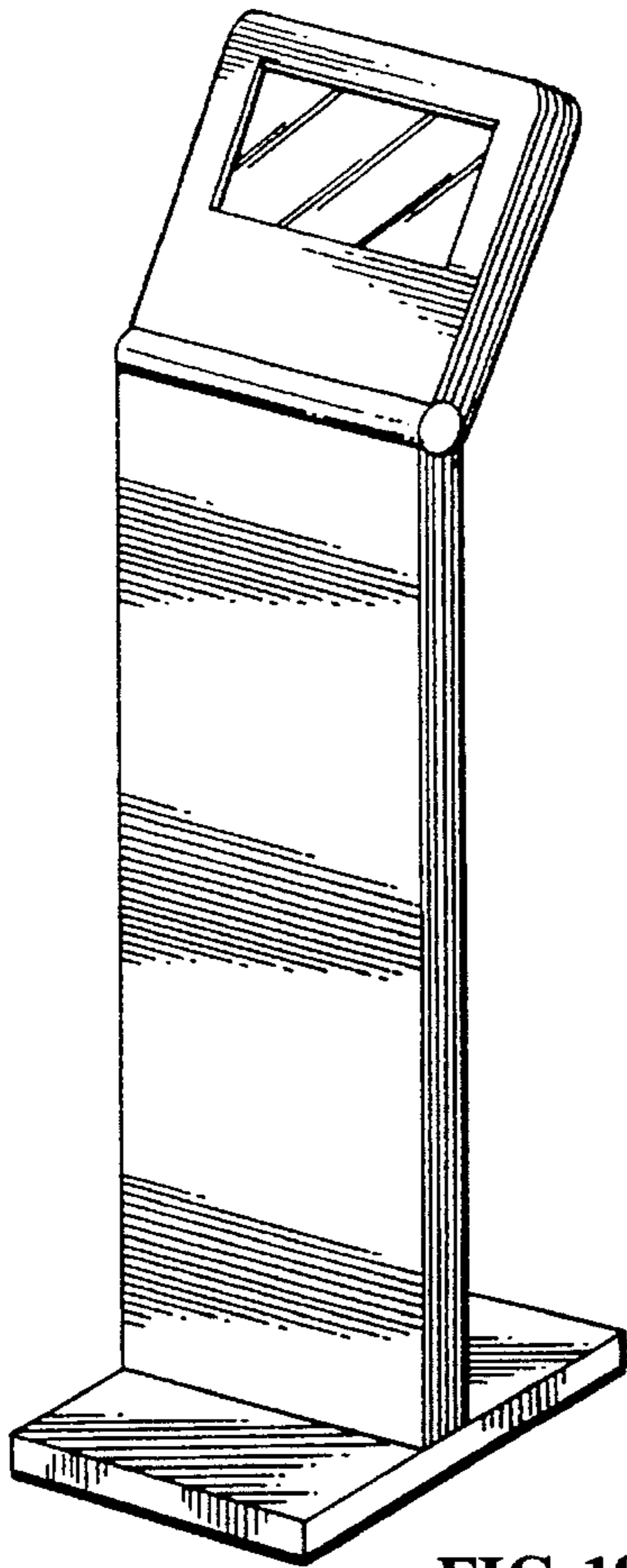

FIG 19

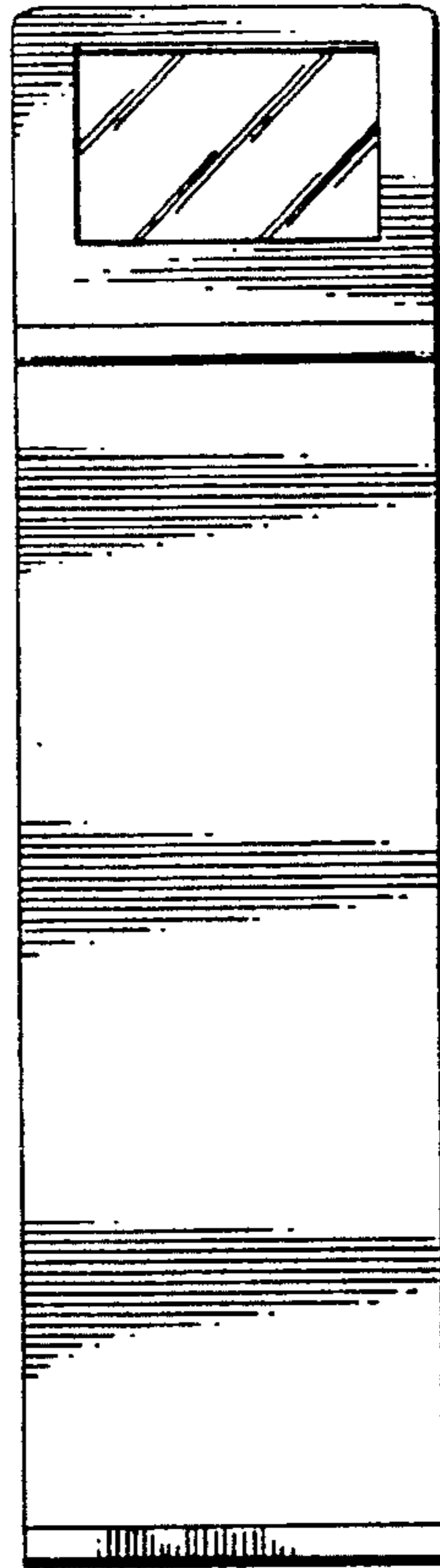

FIG 20

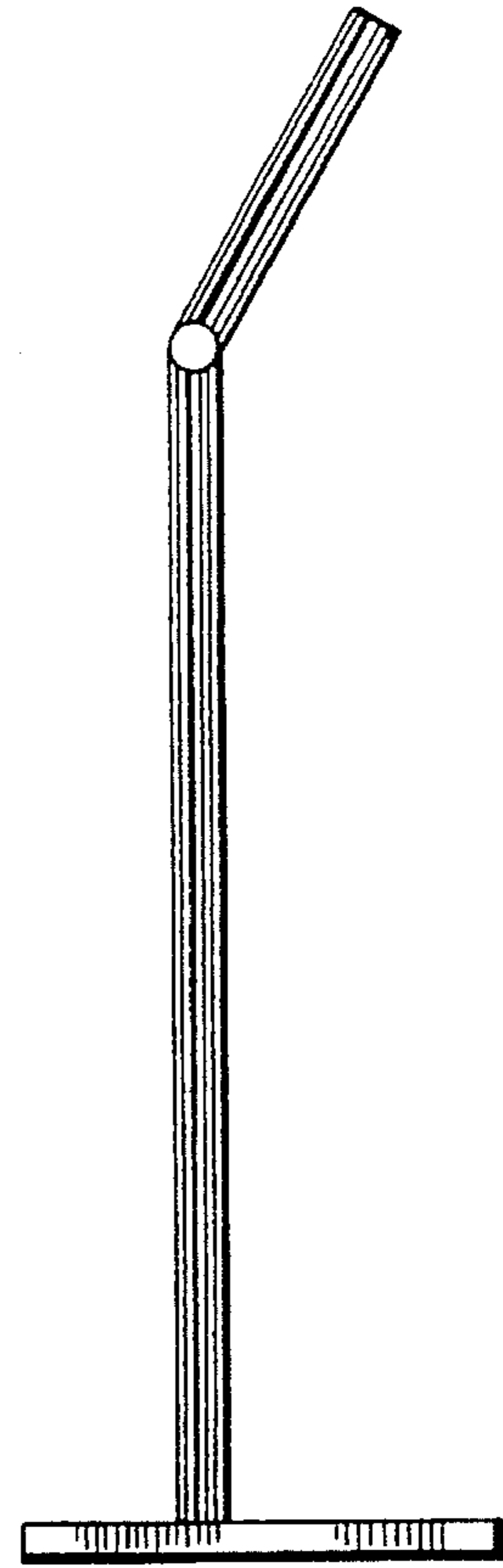

FIG 22

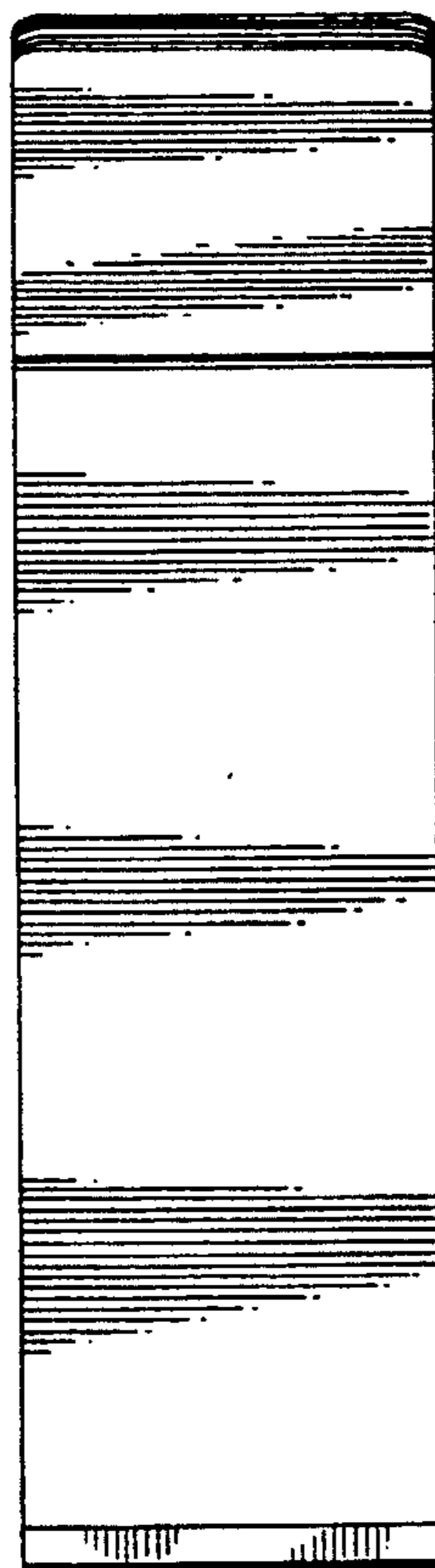

FIG 21

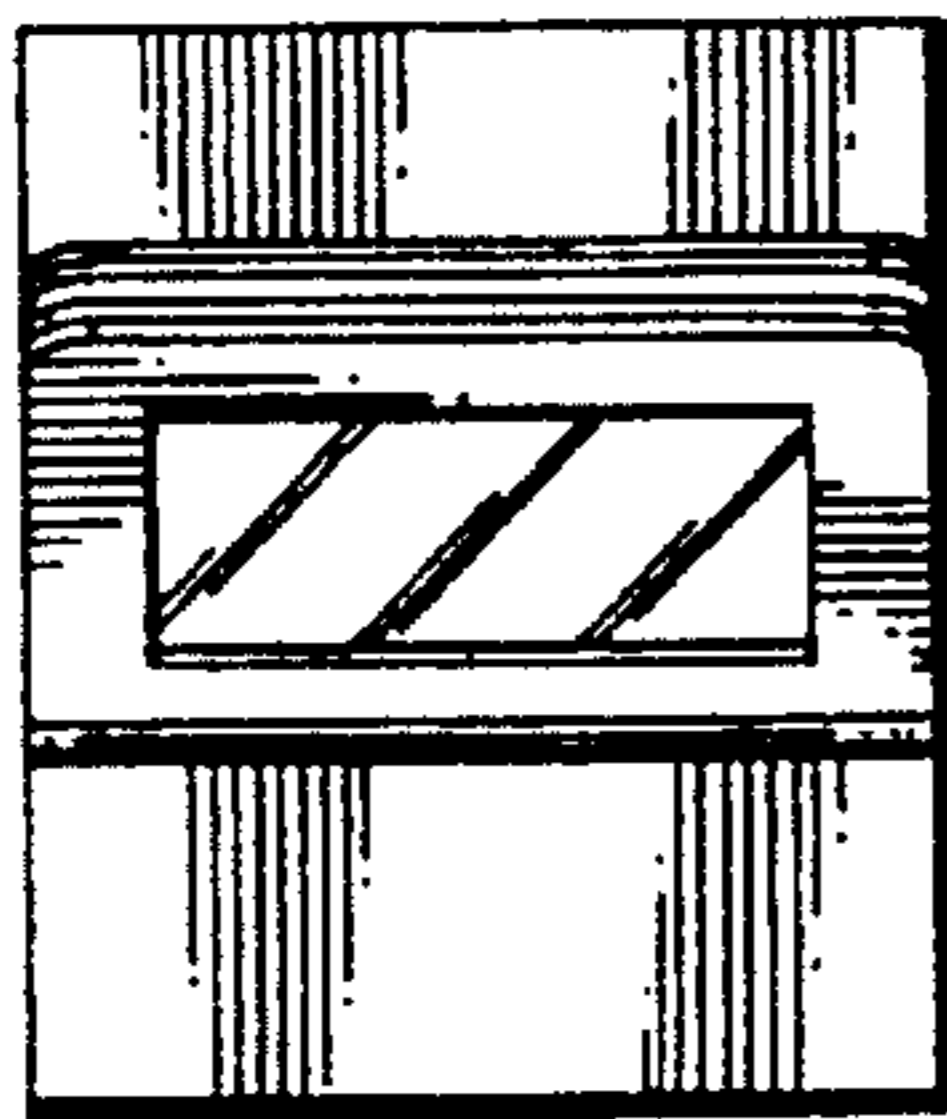

FIG 23

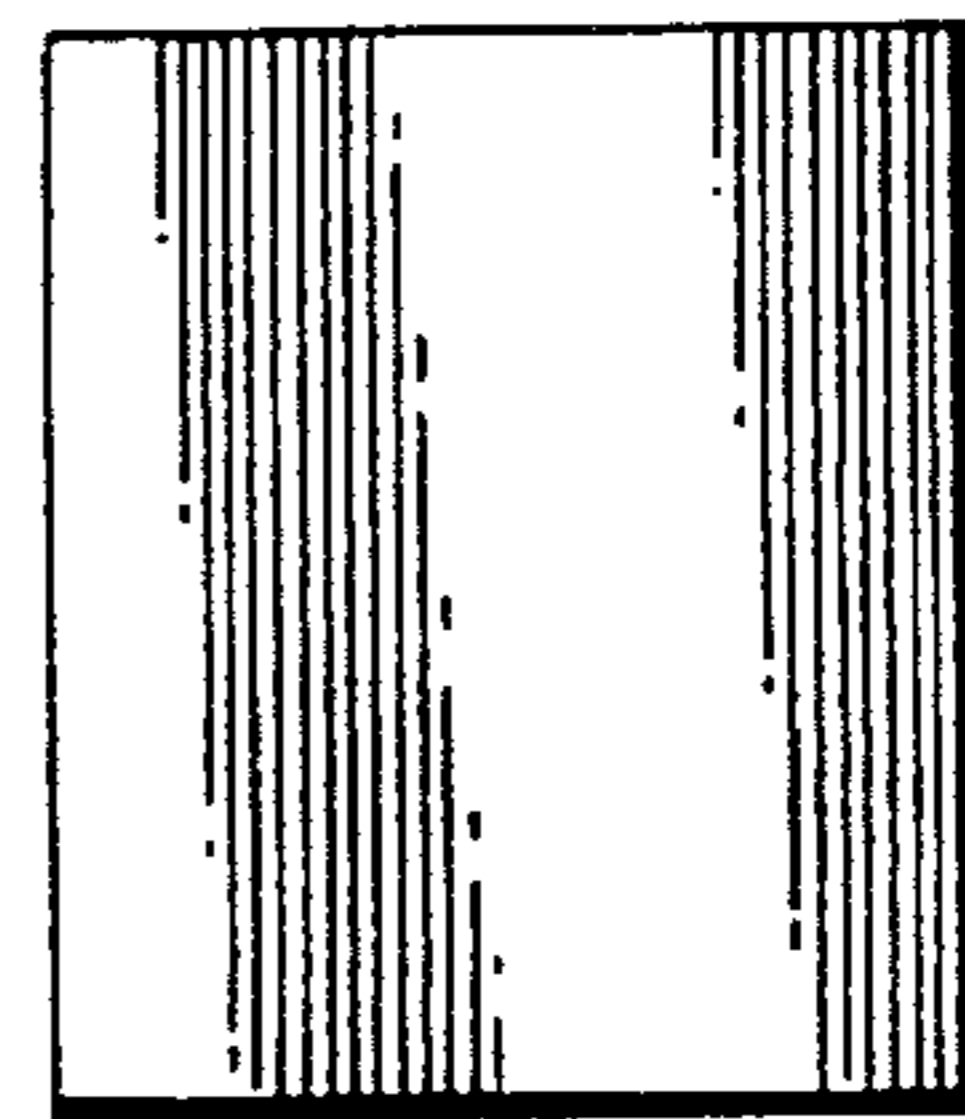

FIG 24

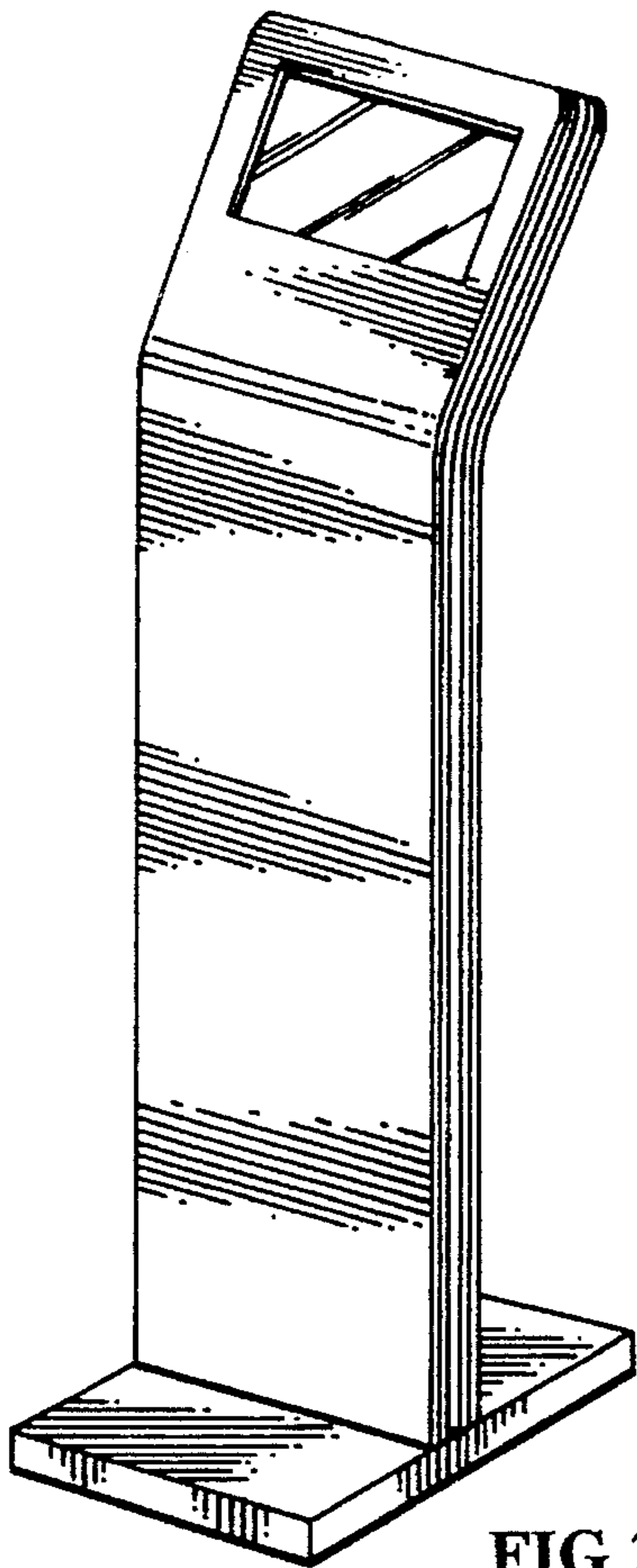

FIG 25

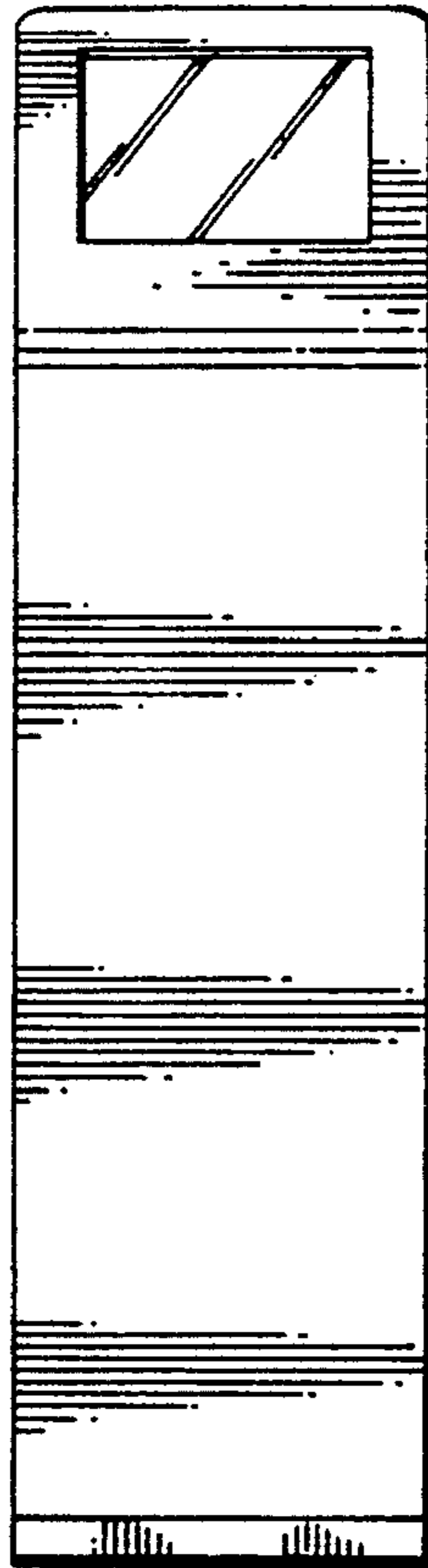

FIG 26

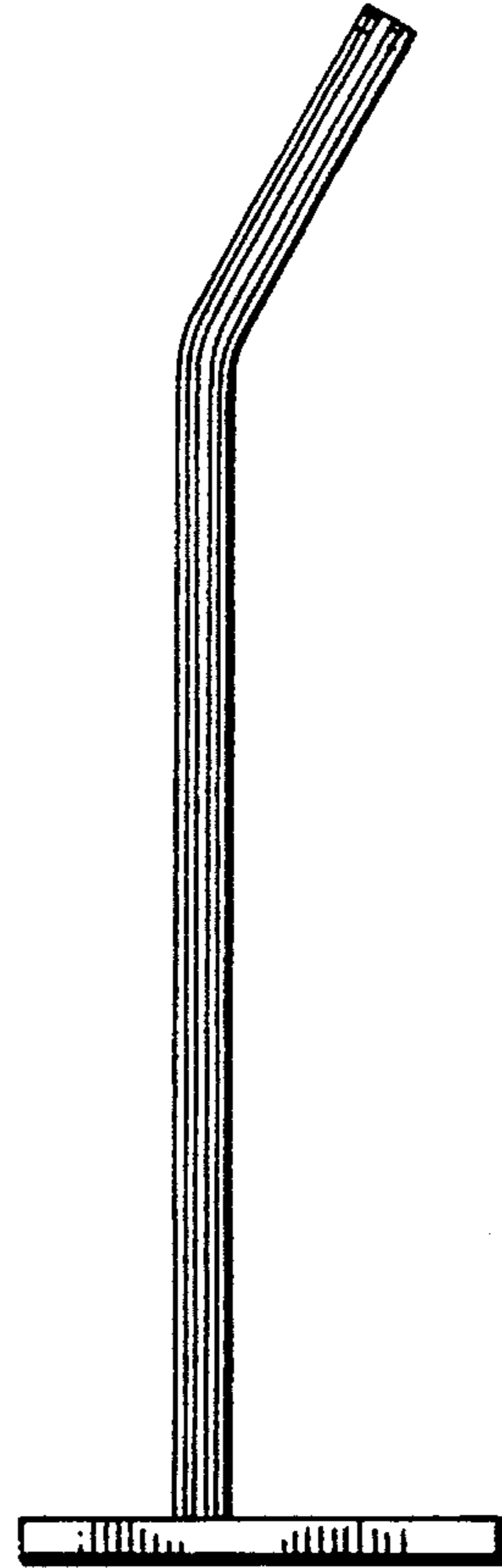

FIG 28

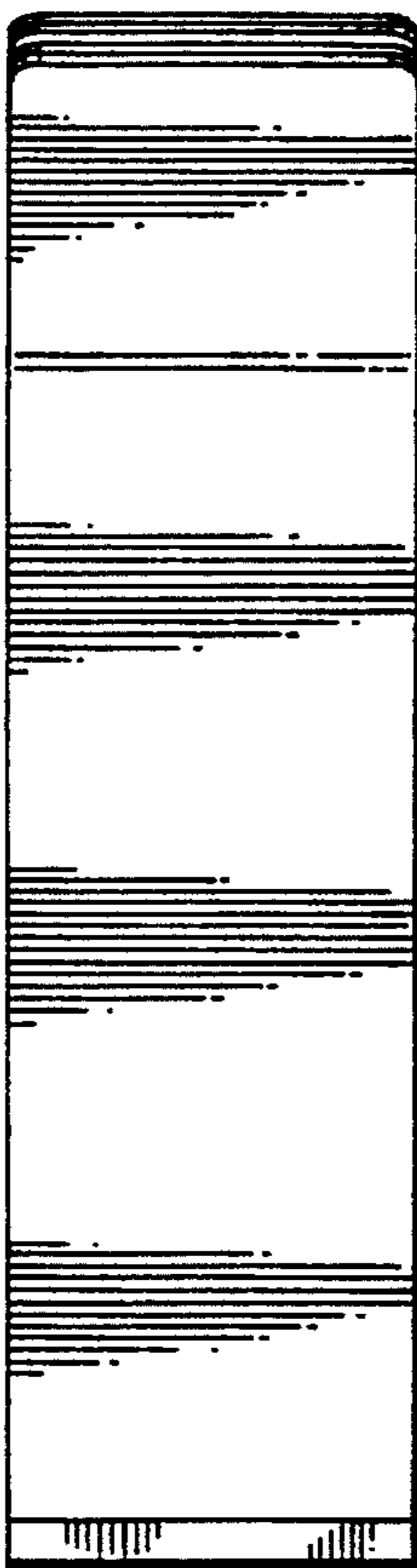

FIG 27

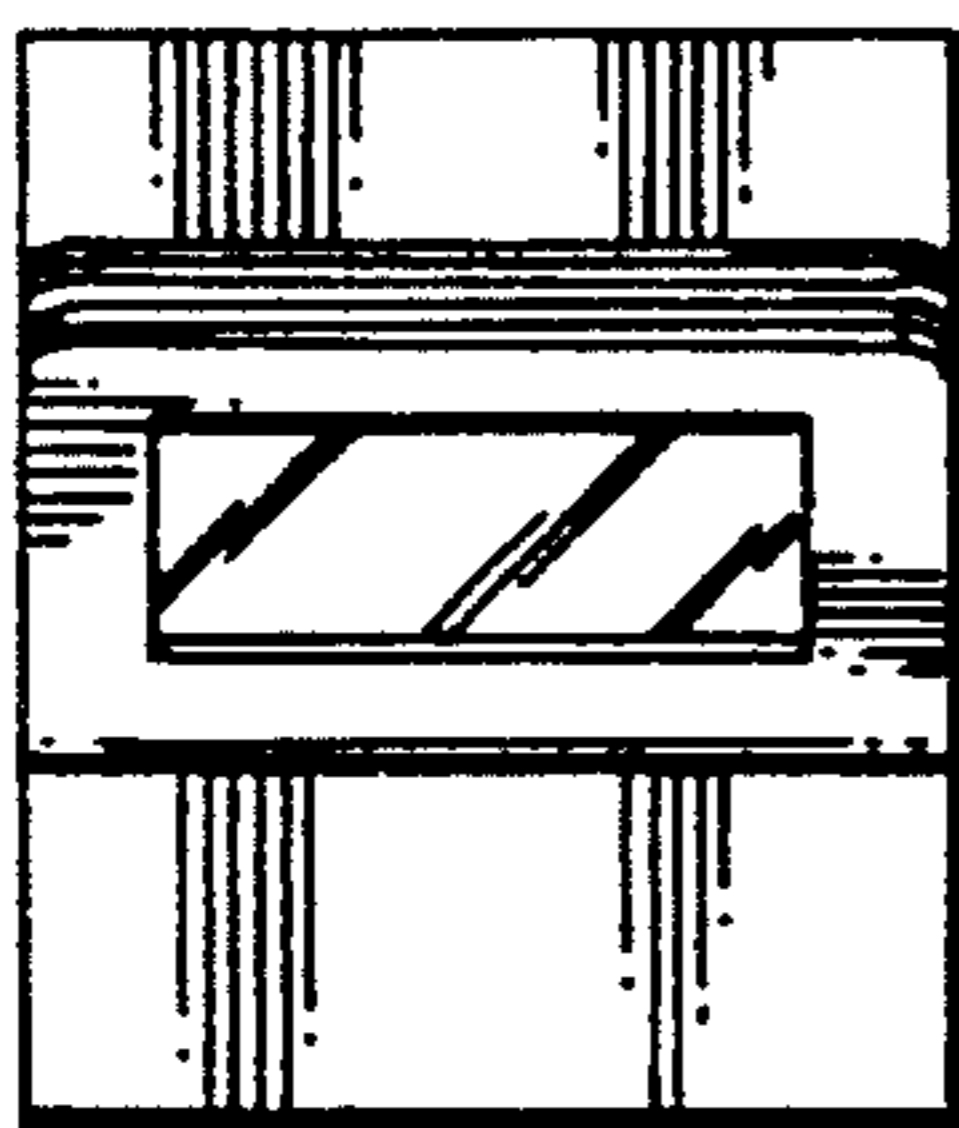

FIG 29

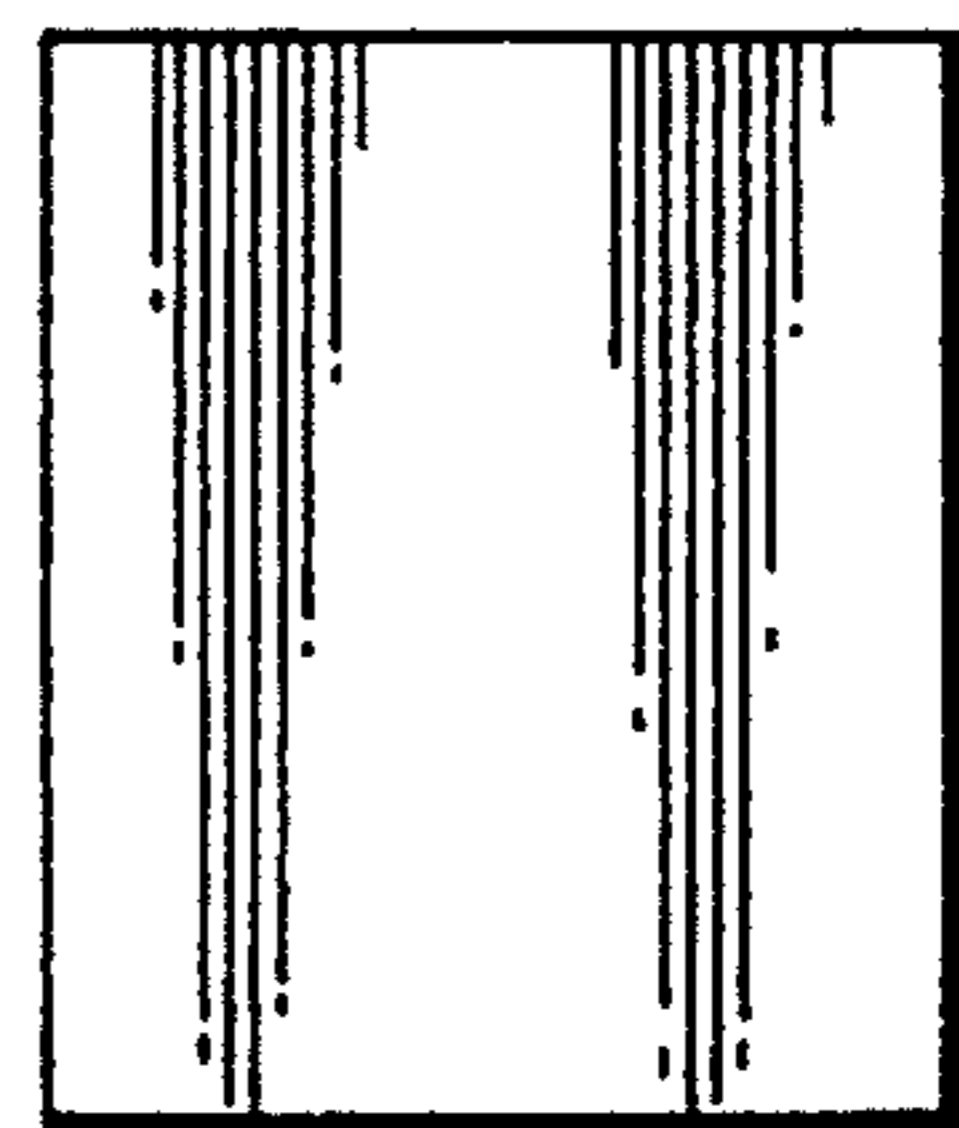

FIG 30