



US00D377894S

United States Patent [19] Sung

[11] Patent Number: **Des. 377,894**

[45] Date of Patent: ****Feb. 11, 1997**

[54] **IMPACT WRENCH**

[75] Inventor: **Eric Sung**, Ta-Li, Taiwan

[73] Assignee: **K. K. U. Limited**, Japan

[**] Term: **14 Years**

[21] Appl. No.: **43,731**

[22] Filed: **Sep. 11, 1995**

[52] U.S. Cl. **D8/68**

[58] Field of Search D8/61, 62, 68;
D15/124, 132; 81/54, 57.13, 57.14, 177.1,
177.85; 140/122, 124; 173/169, 170; 239/525,
526, 527, 528, 589; 408/124, 125

[56] **References Cited**

U.S. PATENT DOCUMENTS

D. 340,396	10/1993	Ichikawa	D8/68
D. 358,314	5/1995	Izumisawa	.	
4,204,580	5/1980	Nally	173/170
4,886,215	12/1989	Ruud	239/526
5,035,161	7/1991	Huang	81/54

OTHER PUBLICATIONS

Automotive Power Tools, Ingersoll-Rand Catalog, 1992, pp. 10, 12 and 13.

Automotive Air Tools, Chicago Pneumatic Catalog, Mar. 1990, p. 2.

RODAC 4103 Air Hammer, RODAC Industrial Air Tools Catalog RIT75, p. 18.

Zone King Air Impact Wrench Modek ZK-502, Zone King Industrial Co., Ltd. Catalog, p. 3.

RF® Air Hammer Model RF-502, RF® Air Tools Poster.

Primary Examiner—James M. Gandy

Assistant Examiner—Robert M. Spear

Attorney, Agent, or Firm—Greer, Burns & Crain, Ltd.

[57] **CLAIM**

The ornamental design for an impact wrench, as shown and described.

DESCRIPTION

FIG. 1 is a left-side view of the impact wrench showing my new design;

FIG. 2 is a rear view thereof;

FIG. 3 is a top view thereof;

FIG. 4 is a right-side view thereof;

FIG. 5 is a front view thereof; and,

FIG. 6 is a bottom view thereof.

1 Claim, 2 Drawing Sheets

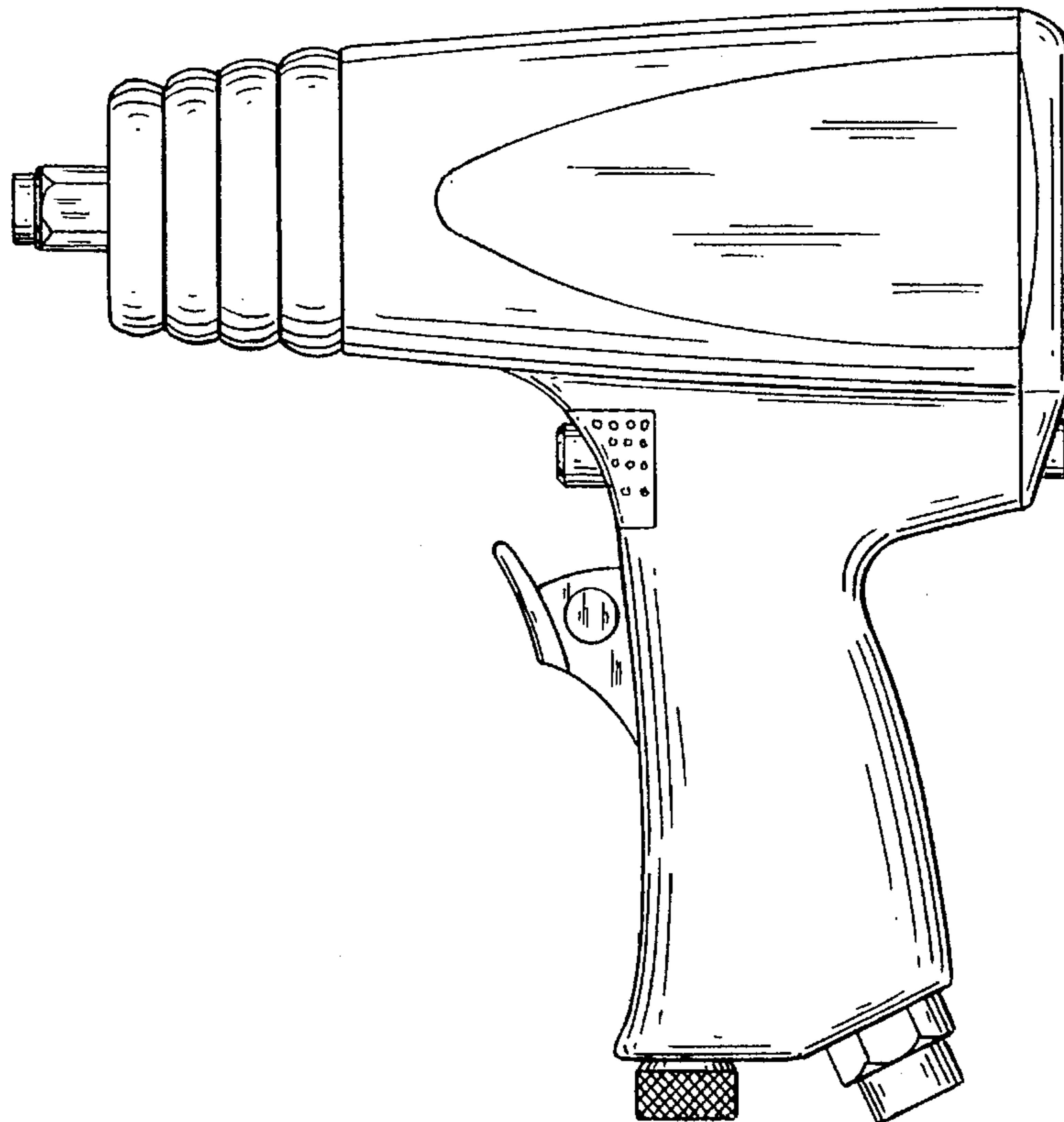

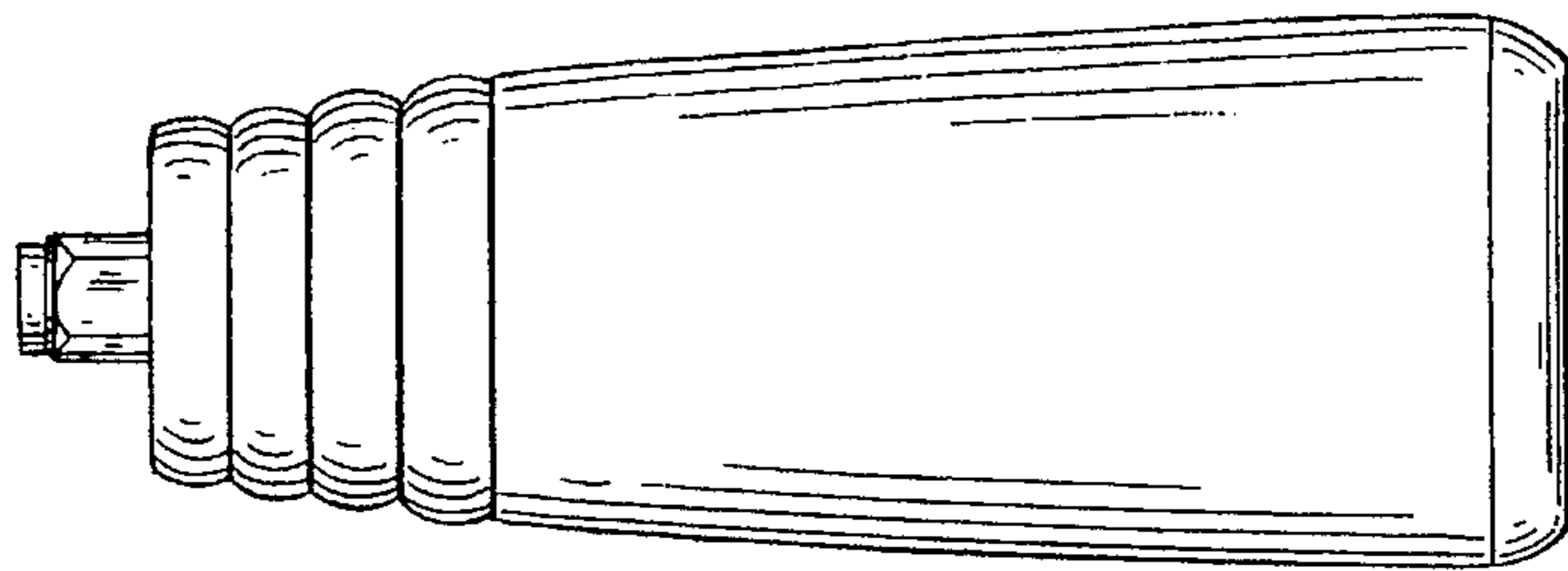

FIG. 3

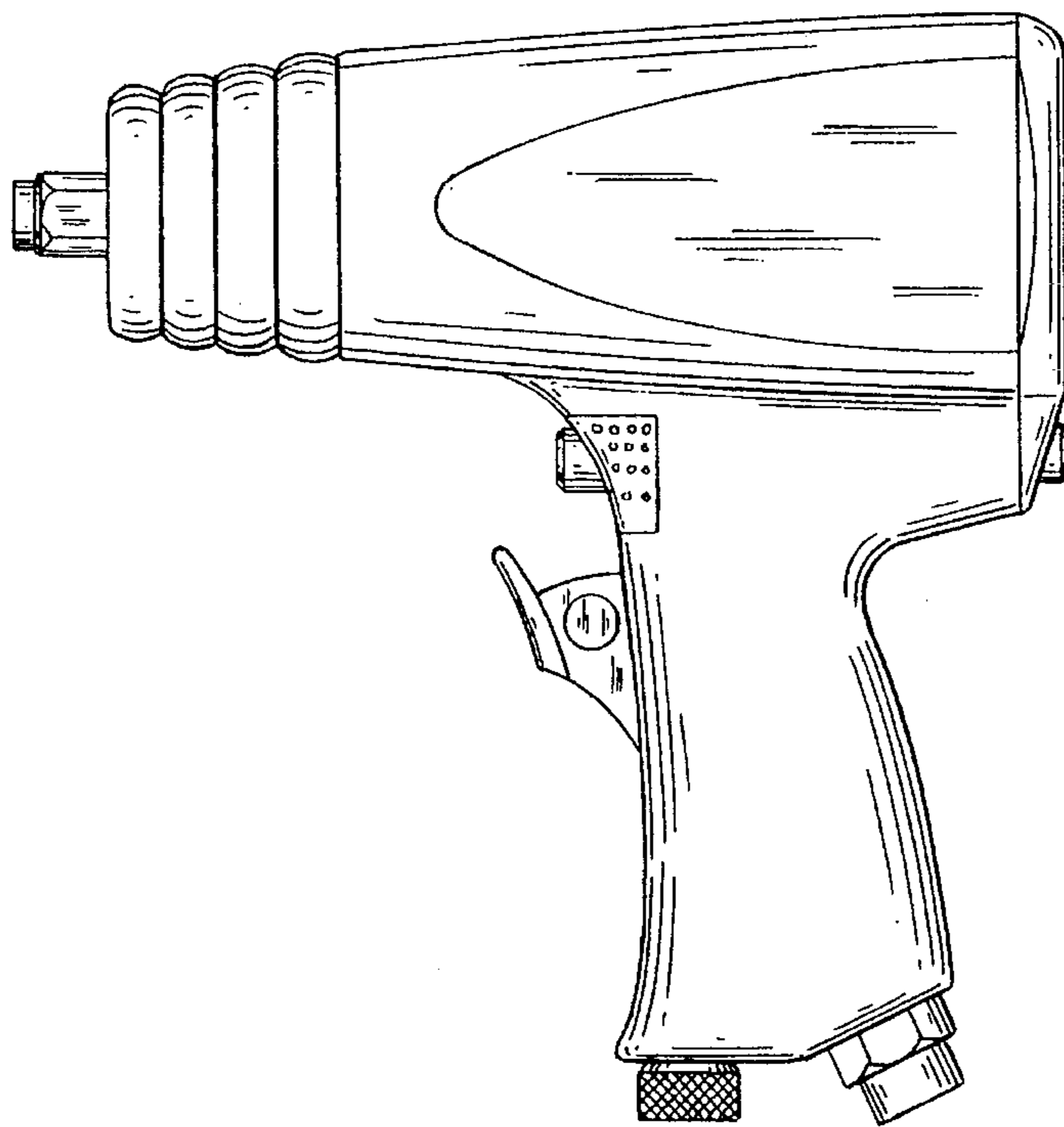

FIG. 1

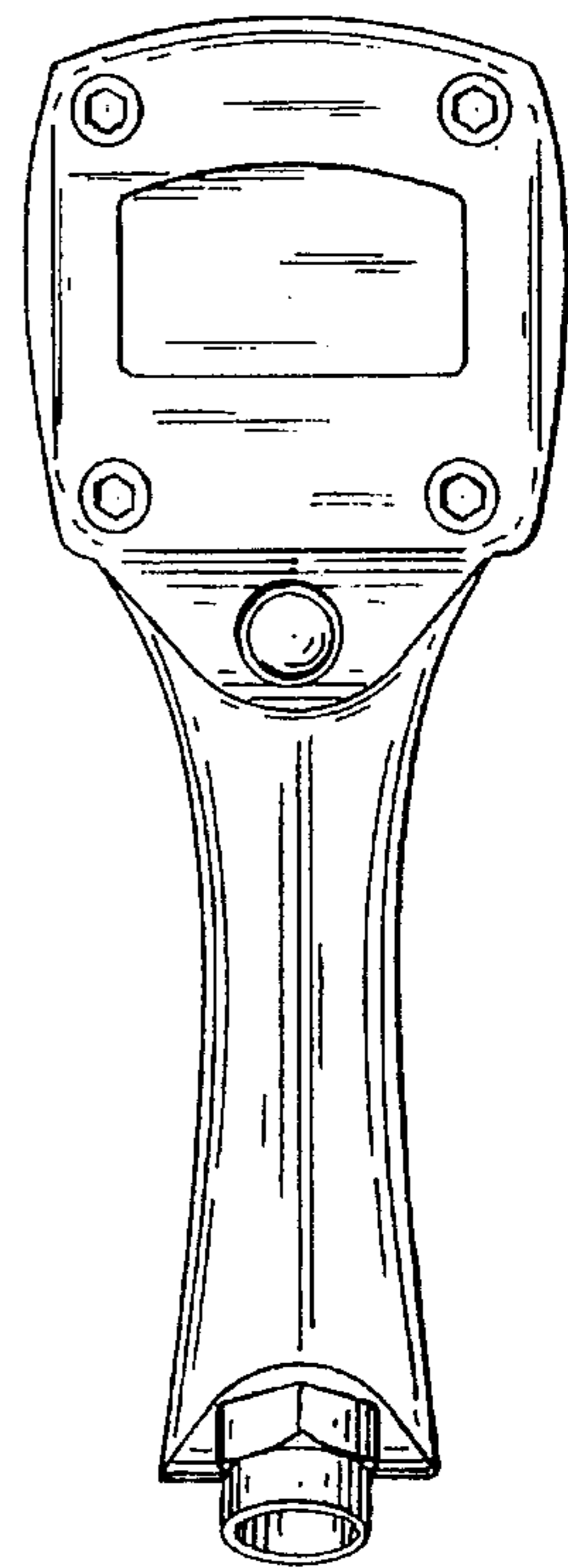

FIG. 2

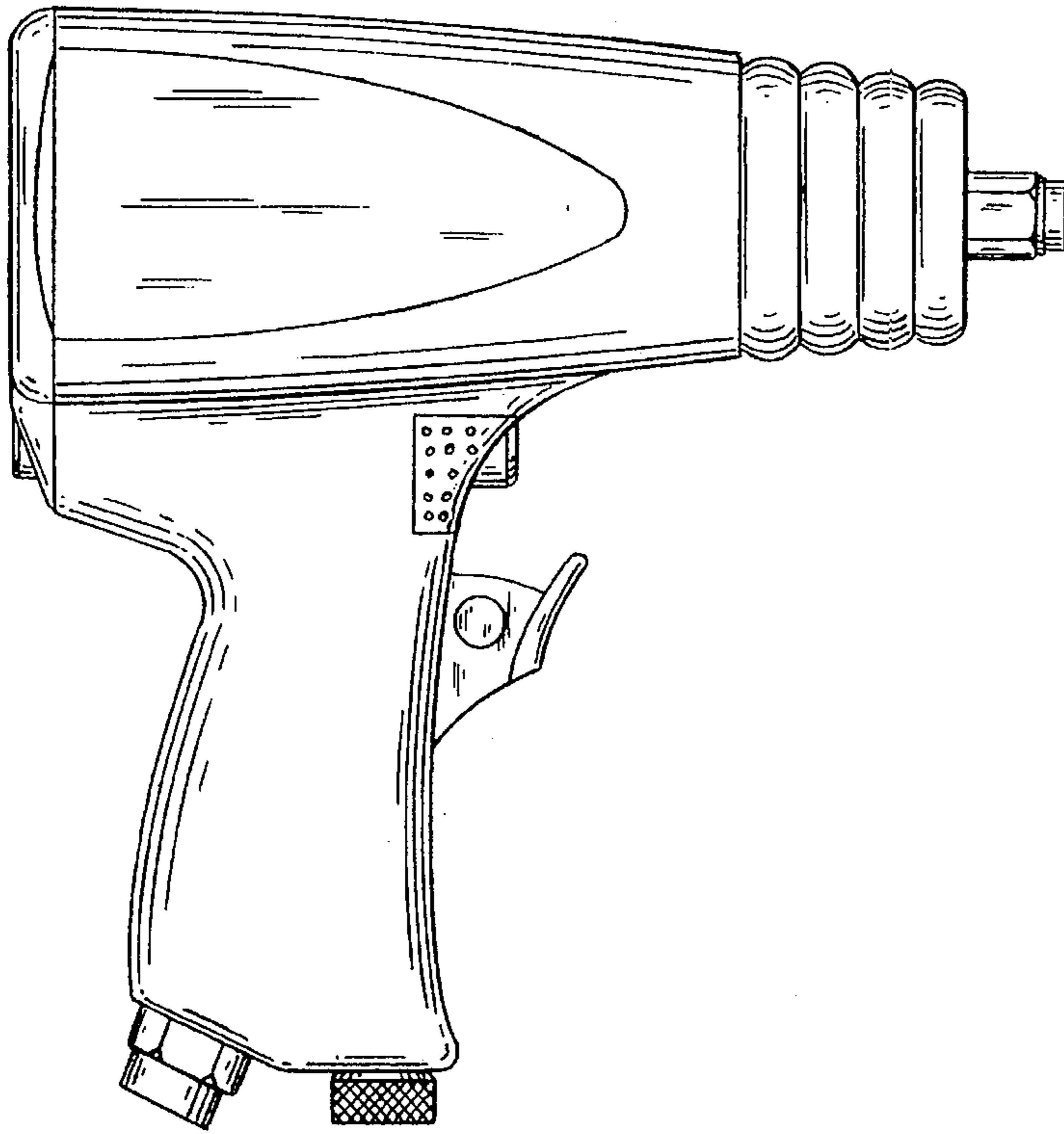

FIG. 4

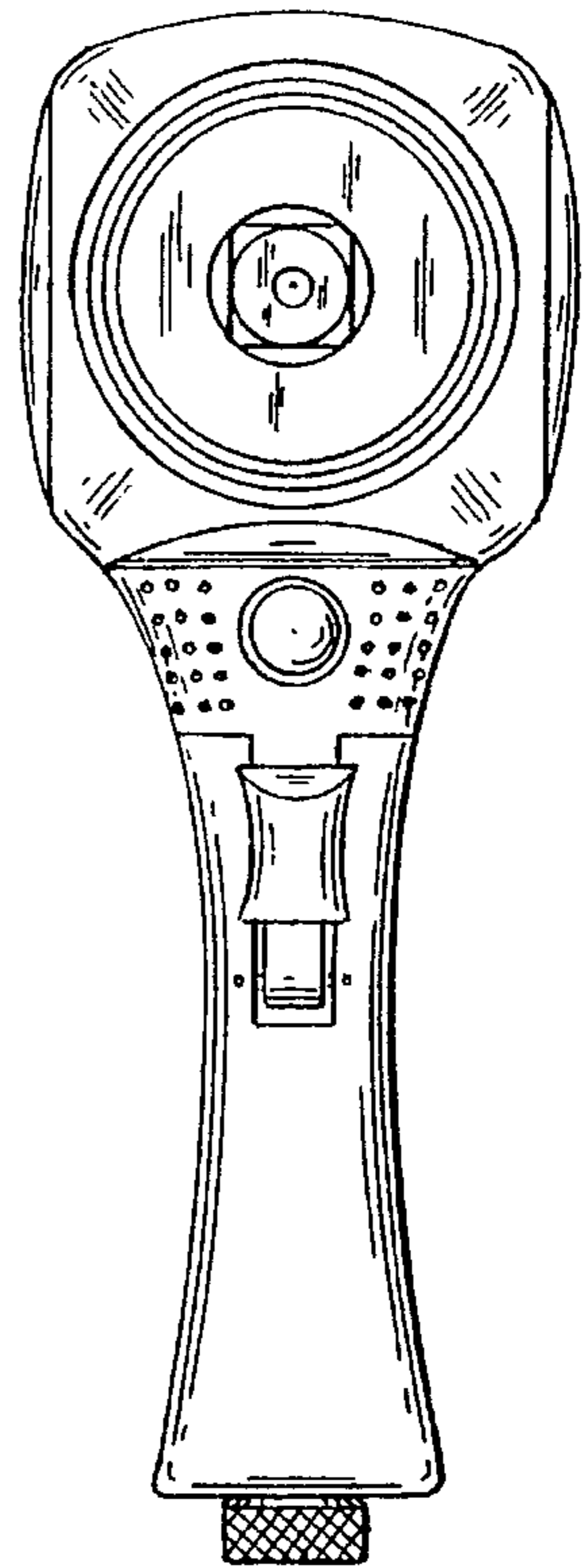

FIG. 5

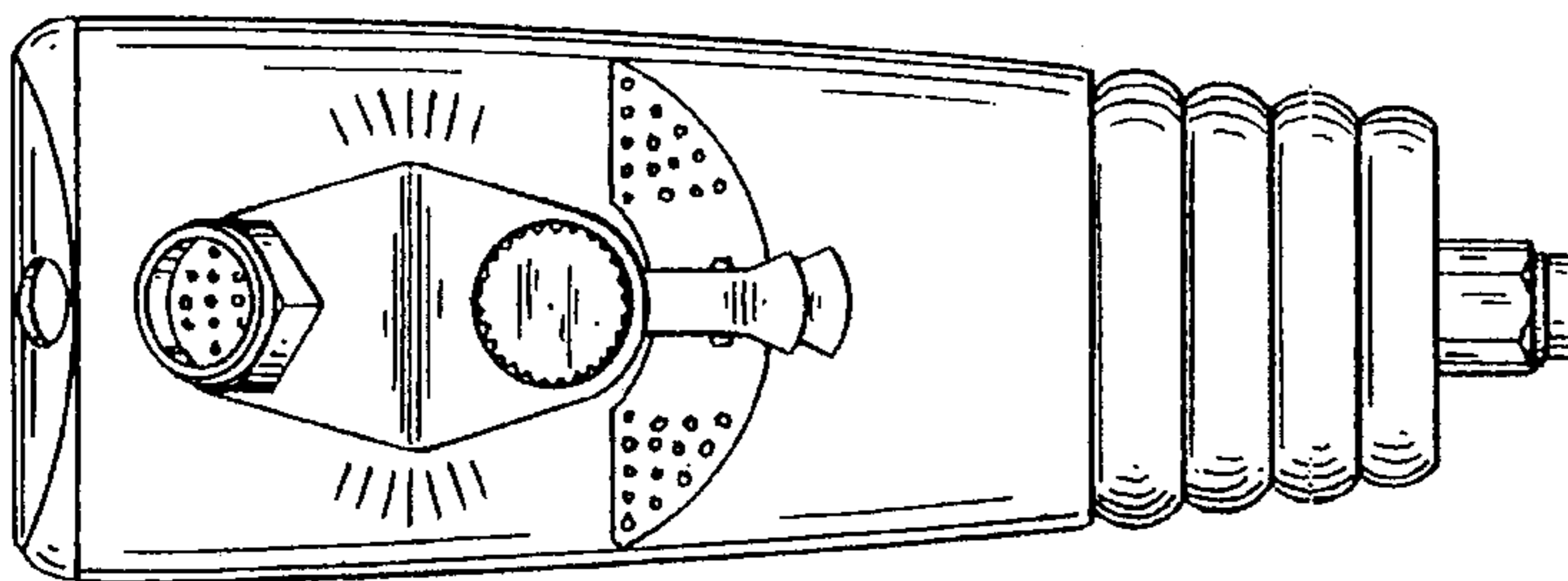

FIG. 6